

Name of discipline:

Transmission systems of access
networks
(TSAN)

Lecturer - Oreshkov Vasiliy Ivanovich

Lecture 4

ASIMMETRICAL DSL TECHNOLOGIES

Main terms and usage specifications

ADSL technology was developed in 90s.

The main objective was to provide video services (6 Mbit/s) on request at a distance of 6 km without replacing existing copper subscriber lines.

The main feature is the different data rates in opposite directions. Since speed "down" (as the subscriber station) is within 0,256 ... 6,144 Mbit/s, the speed "up" - 16 ... 640 kbit/s.

ADSL technology also allows the simultaneous transmission of voice and data with a frequency separation of these signals.

Thus, in an ADSL system, three streams are transmitted simultaneously: voice at the 0.3...3.4 kHz spectrum, high speed data transmission in the subscriber direction ("downstream") and low speed in the network direction ("upstream"). Frequency spectrum of the ADSL-system is shown in Fig. 4.1.

Separation of data and voice signals is done by the frequency divider (splitter). Organization of the ADSL connection is shown in Fig. 4.2.

Separation of transmission and reception signals during work on one pair is carried out by the frequency division or echo canceller.

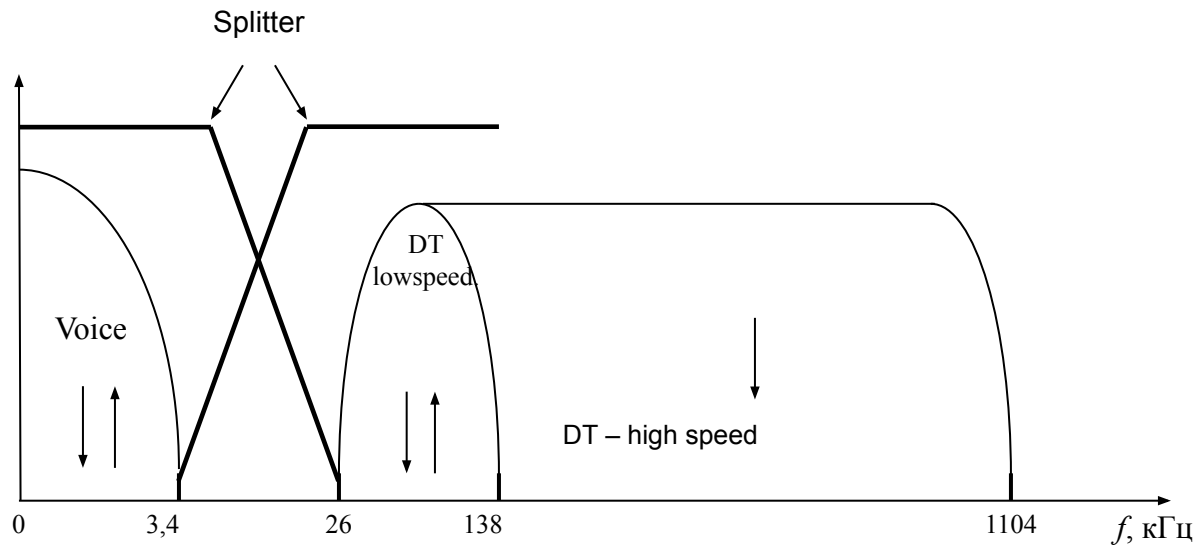

Fig 4.1

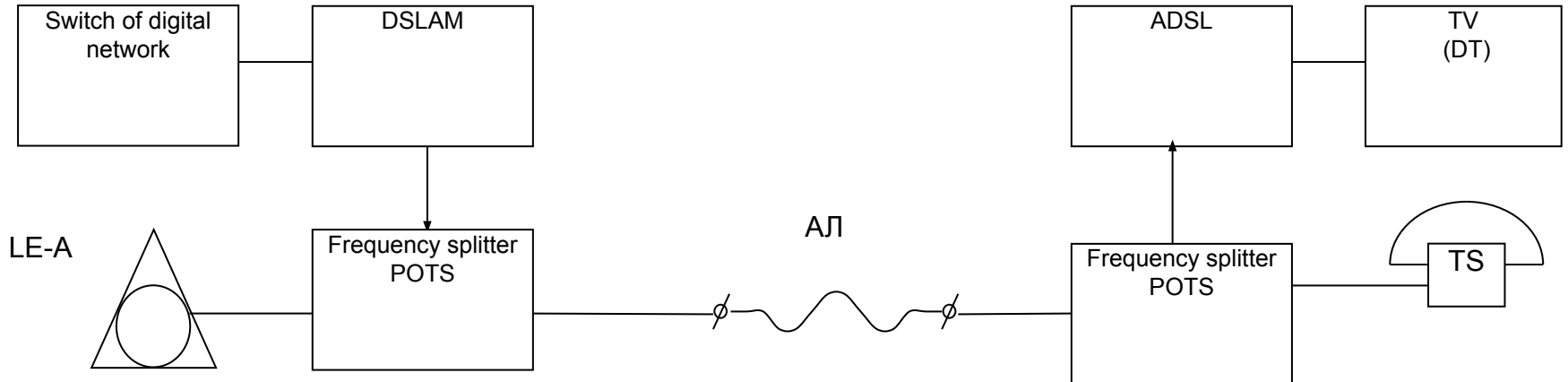

Fig 4.2

Block diagram of the ADSL transmitter

The block diagram of a ADSL transmitter by station block (ATU-C) for Recommendation G.992.1 ITU-T is shown in Fig. 4.3.

Was put the following definition. The ADSL physical channel is called physical channel, and all information and overhead channels called logical or transit channels. All kinds of information except useful information, called service information.

ADSL transmission system (TS) allows simultaneous transmission of signals over one information channel.

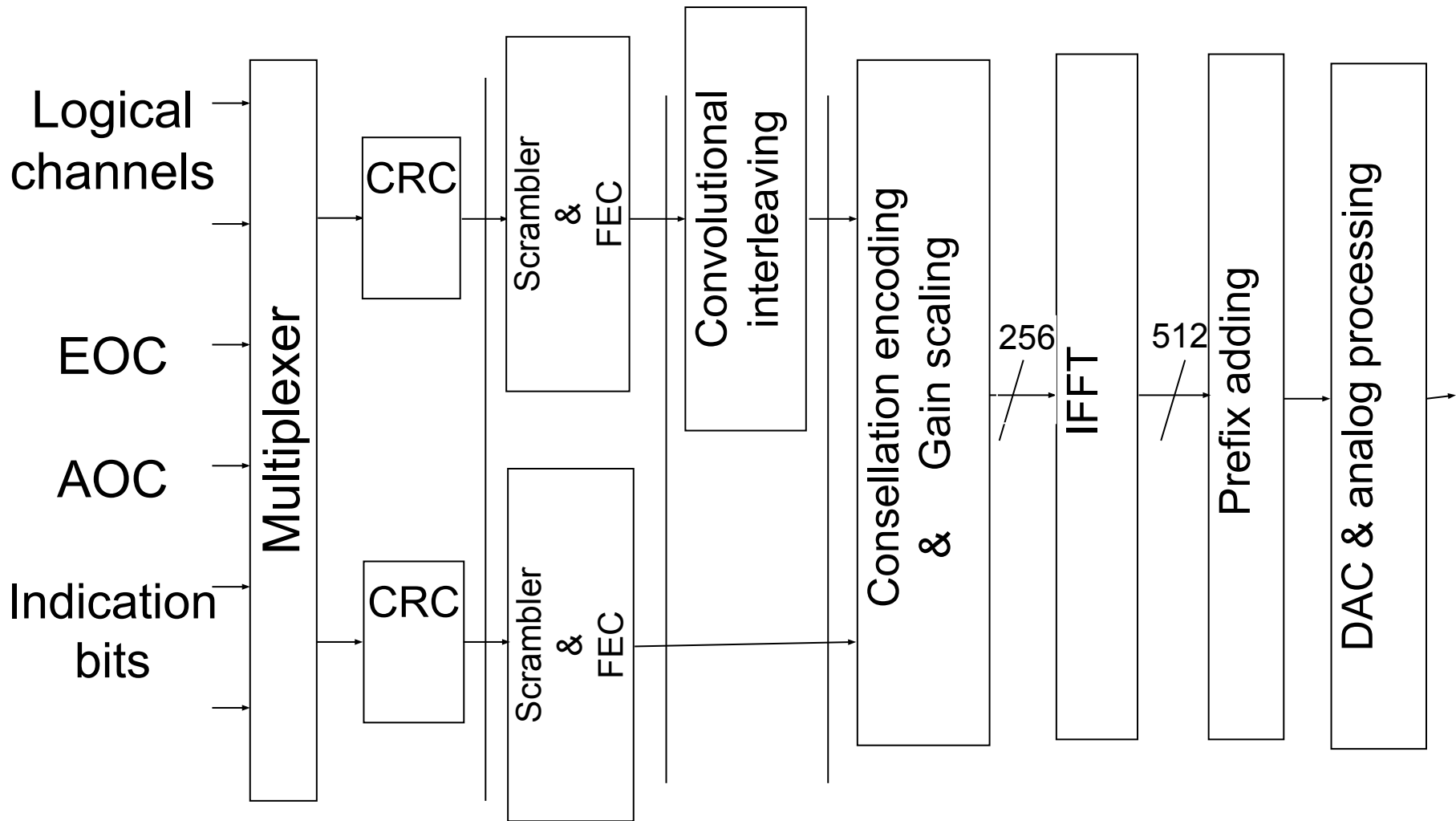

Fig 4.3

For service information transmission using integrated working channel - EOC (Embedded Operations Channel), service control channel - AOC (ADSL Overhead control Channel), and the service bits. Combination and separation of logical channels in the transmitter and receiver by using frame structures. Thus, a series logical channels created in the physical channel ADSL.

A characteristic feature of the transmitter is that it contains two channels - fast and with interleaving (permutational).

Consider the appointment of blocks transmitter.

Block multiplexing combines four simplex (AS0 - AS3) and three duplex (LS0 - LS2) of information (logical) signal synchronized with a clock frequency of 4 kHz, a signal control, administration and operation of two separate data streams: fast and interleaving.

Each of the streams is subject to independent CRC-coding, scrambling and coding solution that corrects errors (FEC – forward error correction), – Reed-Solomon code. Then interleaving path data is amenable to operation of the convolutional interleaving.

Formed streams of binary symbols are distributed through the channels (carriers) of the transmitter according to the optimal allocation of transmit power and number of bits transmitted information on the carriers.

Under this distribution is elected signal constellation type (with the used signal-code structures) and the gain of each channel. As a result, formed a complex vector algorithm becomes IFFT.

Digital signal obtained as a result of the IFFT transform is complemented prefix signals, is converted into an analog signal and transmitted to a subscriber line.

Logical channels and frame structure of ADSL

There are 7 channels in ADSL.

Table 5.1 Logical channels ADSL G.992.1

Channel name	Type	Bitrate B, kbps	Aim
AS0	Simplex	0 – 6144	For downstream (often only)
AS1	Simplex	0 – 4608	For downstream
AS2	Simplex	0 – 3072	For downstream
AS3	Simplex	0 – 1536	For downstream
LS0	Duplex	0 – 640	For work in both directions (often only)
LS1	Duplex	0 – 640	For work in both directions
LS2	Duplex	0 – 640	For work in both directions

ADSL logical channels are combined and separated in accordance with the frame and the multiframe structure of ADSL. Multiframe has a duration of 17 ms and consists of 68-frames (cycles) of information and a 1 frame synchronization. The frame rate $\approx 4,0588$ kHz. The informational frame rate – 4 kHz.

Structure on informational frames is shown in Fig. 4.4.

Detailed structure of half frame of down and up transmission streams of fast transmission path is shown in Fig. 4.5.

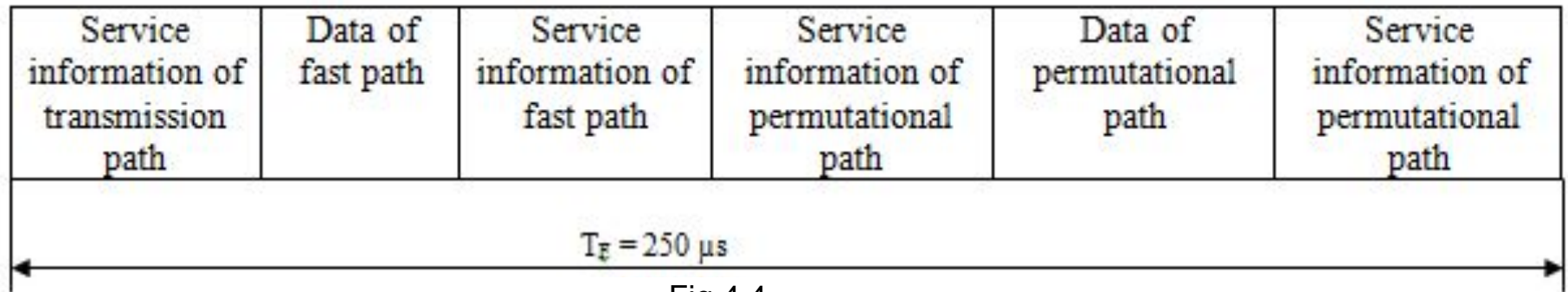
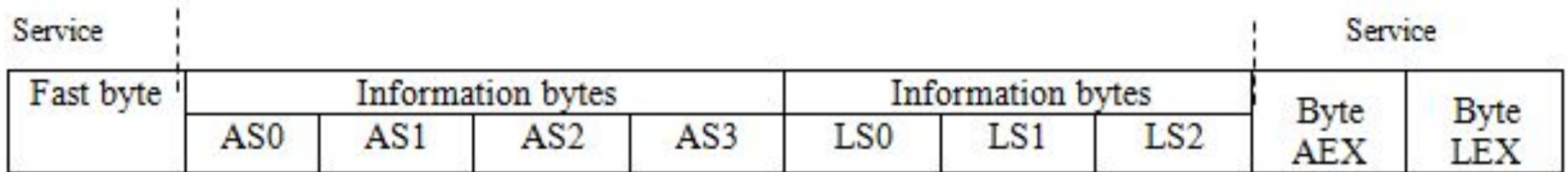
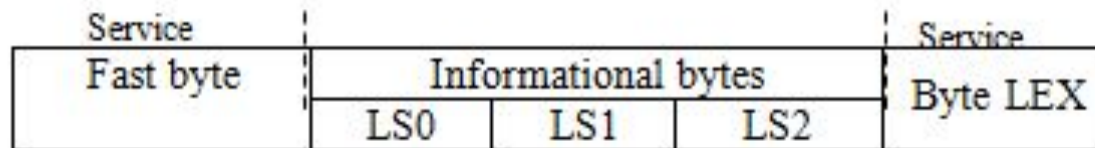

Fig 4.4



a) «Fast» byte, downstream



б) «Fast» byte , upstream

Fig 4.5

"Fast" byte, depending on the frame number (0 ... 67) performs four functions: transmission check of CRC-code for the superframe; indicator bit transfer, an internal transfer operation channel EOC; information transfer of timing control to synchronize the logical channel with the user's bitrate.

Since the distribution of information in the frames is performed with a frequency of 4 kHz, the bitrate is $4 \times 8 = 32$ kbps. The real bitrate over an informational channel is: $B = n$ bytes per frame \times 8 bit/byte \times 4000 frames/s.

Features of ADSL deployment in Ukraine

Differences between subscribers networks from Western Europe and Ukrainian

Significant impact on the implementation strategy of ADSL have different principles of local networks in Ukraine compared with European countries. Also we have different electromagnetic environment, the parameters of cables and equipment which is already working in the network (LE).

The main differences are:

- different construction principles of subscribers networks;
- different twist and a core diameter of cables;
- differences in equipment (in LE) used in the network;
- other electromagnetic.

1. In national telephone networks built on the analog LE, subscriber lines are much more extensive. Their maximum length is determined by the rate of attenuation of 6 dB at 1 kHz (КНД 45-076-98). In Europe and in Russia, this parameter should not exceed 4.5 dB (Russian OCT 45.36-97).

2. The deployment of digital networks in Ukraine , as a rule , is carried out by replacing the analog LE by digital (DLE) and direct switching of subscriber lines (without conversion of cable networks). In Europe, the reconstruction of local networks was carried out by moving from concentrated ALE to distributed DLE (ITU-T Q.5xx). In this case, the radial service area of ALE was transformed into multiple zones (cells) around the DLE and its outstations . This has led to a decreasing of the maximum length of subscriber lines and the amount of hardware node.

The maximum length of subscriber lines in many European countries is less than 1.5 km .

3. In Europe its mostly star-quad (звездной скрутки) cables are laid with a large diameter of conductors. In particular, according to the "Telekom Slovenije", whose experience in implementing of ADSL (xDSL) was introduced in Ukrtelecom. In cable connection of the local network diameter distribution is like this: 0.4 mm - up to 20%, 0.6 mm - up to 70%, 0.8 mm - 10%.

In the national local networks core diameter of 0.4 mm is most common with a large proportion of couples with a diameter of 0.32 mm.

4. In accordance with the recommendation of ITU-T G.992.1, ADSL line limit length is determined by the effective attenuation of 60 dB at 300 kHz. Because of the differences in diameter cores, we can obtain the maximum range of ADSL without interference in Europe is 7.5 km (for $60 \text{ dB} / 8 \text{ dB/km} = 7.5 \text{ km}$), and in Ukraine - 4.0 km (the same $60 \text{ dB} / 15 \text{ dB / km} = 4 \text{ km}$).

Comparative parameters of access networks are given in Table. 4.2.

Table 4.2 – Parameters of access networks

Typical parameters of subscriber lines		Europe	Ukraine
Cable	Type	TK 59GM	ТП
	Twisting	quartile	Pair
	Main group	5 quads	10 pairs
The most common core diameter, mm		0,6	0,4
Linear resistance of loop pair is not more , Ohm/km		130	296
Capacitance is no less than, nF/km		42	60
Pair attenuation at frequency 300 kHz, dB/km, at least		8	15
Attenuation of asymmetry (in a range to 20 Hz), at least, dB		50	40
The minimum value of NEXT crosstalk between adjacent pairs of the beam (in a range to 2MHz), at least, dB		60	40

Recommendations for networks deployment

Basing on the results of the research, experimental installations and digital lines of the measuring work in advanced areas of Odessa and Kiev, the following recommendations can be offered.

1. During the deployment process of the xDSL-subscriber lines on the existing local telephone lines, network, operators (service providers) control the power of the longitudinal and transverse interference on ADSL frame interval in the frequency band which is used in this technology (for the stational and the subscriber-side lines).

2 In the replacing process from the analog TE to digital LE, the area of customer service should be gradually transformed from radial (ALE center) in a distributed (DLE with removals). Number of removals must typically be not less than four - to cover the entire service area of replaceable ALE.

3 Clearances should be located within a distance of 2 km from each other and from the central unit of the digital exchange, which would reduce the maximum length of the lines up to 1.5 km.

4 Capacity of subscriber terminations of the central unit of the digital exchange and any removal should not exceed 10,000 numbers.

This will reduce the noise induced by the network equipment as well as electrical circuits, power and ground.

5 Once again paving sections of the main and distribution cable must be performed by quad cable with a wire diameter of 0.4 mm. Changing the type of twist from a ten paired to quartile will increase protection against crosstalk, and increase the diameter of cores will reduce fading, and raise the potential of high-speed cable lines.

6 In the ADSL-lines should be applies special linear profiles that provide frequency management.

7 Designing of access networks and the conclusion of agreements on the provision of services based on ADSL should be carried out with the usage of normalized speed performance.

8 The line speed potential which is not correct, should not be allowed to use (culling (выбраковка) or repair).

9 Control of the influence of power and ground circuits for the operation of the digital lines should be carried out in accordance with international recommendations.