

Тема 1

Жизненно важные цели

Стратегические ориентиры

Баланс интересов

Огнёв

Александр Сергеевич

доктор психологических наук, кандидат физико-
математических наук профессор
декан ф-та психологии и педагогики РосНОУ

Раздел 1. Зачем?

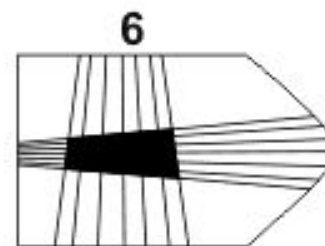
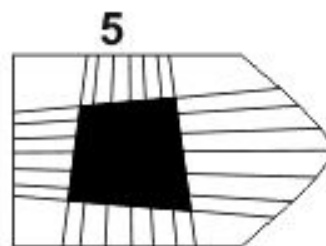
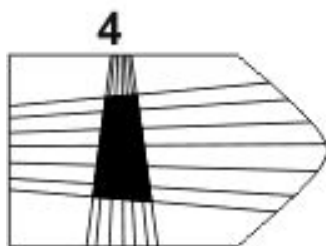
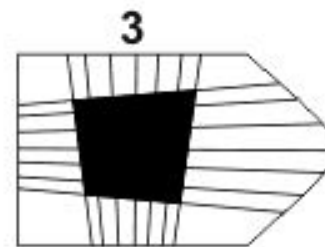
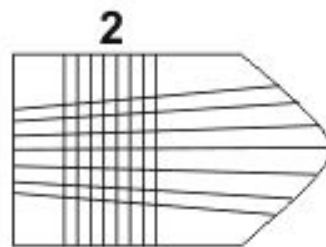
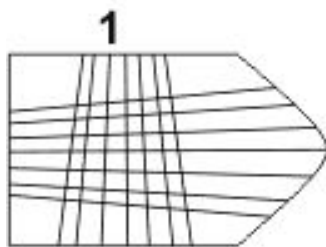
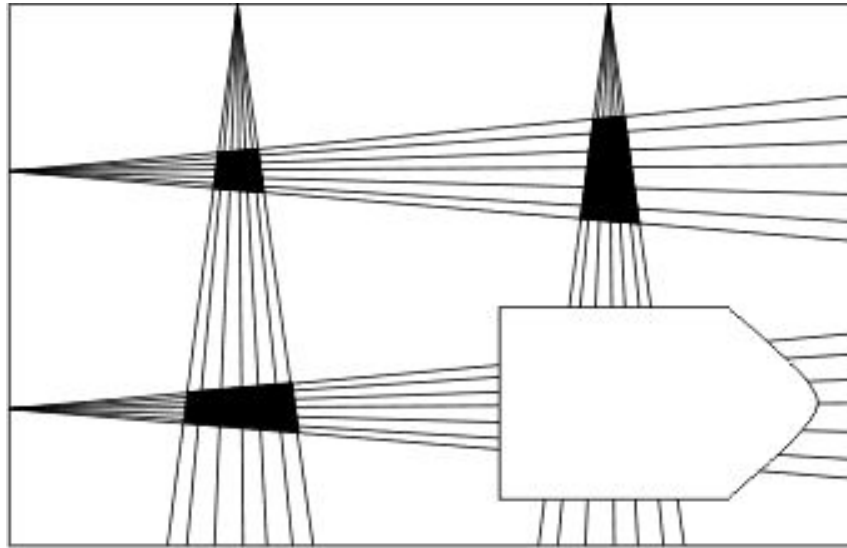

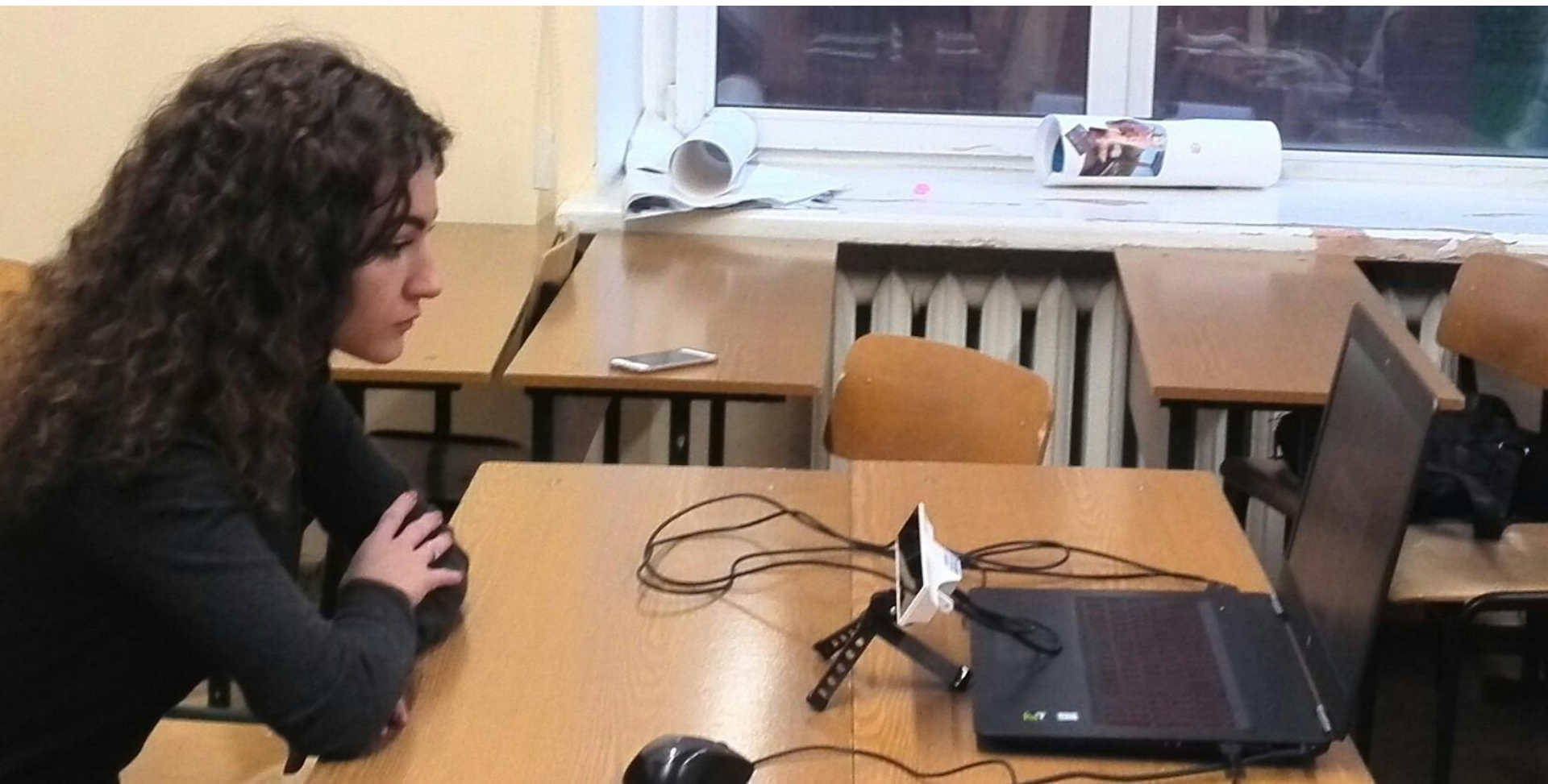

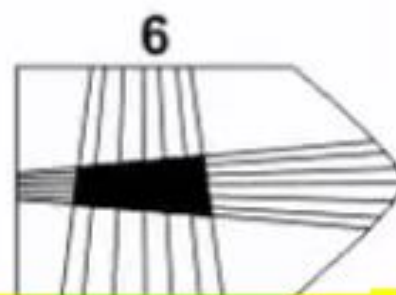
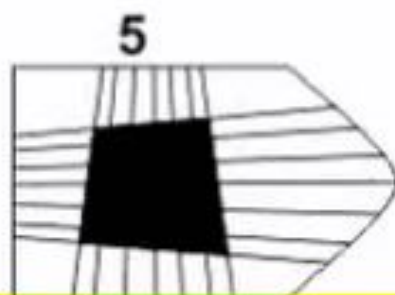
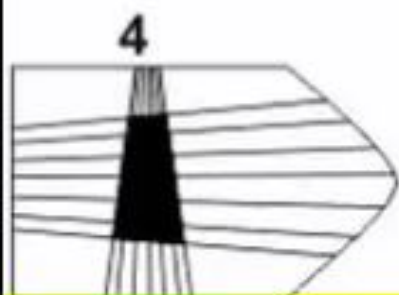
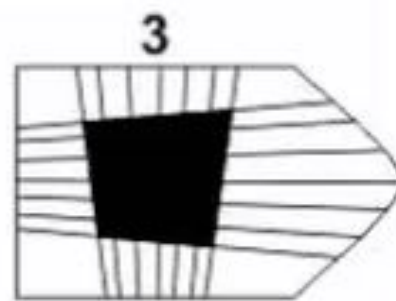
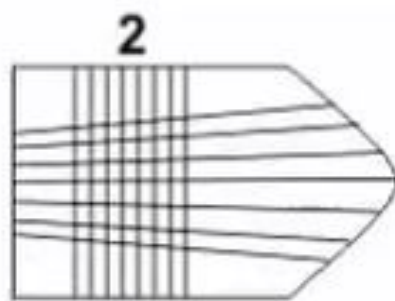
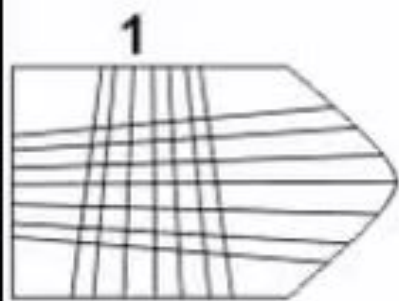
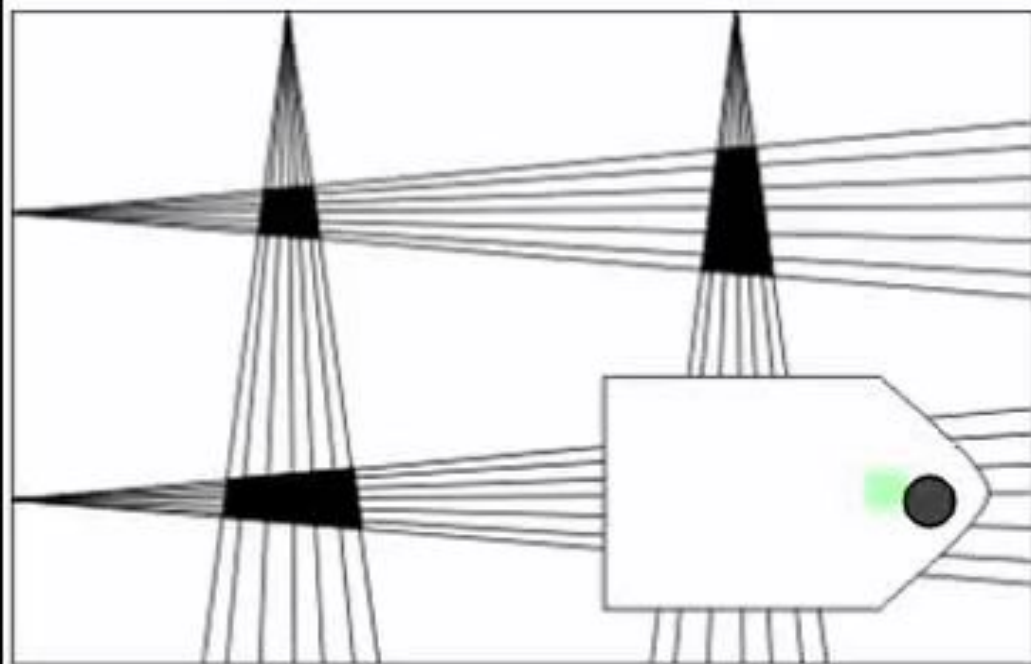

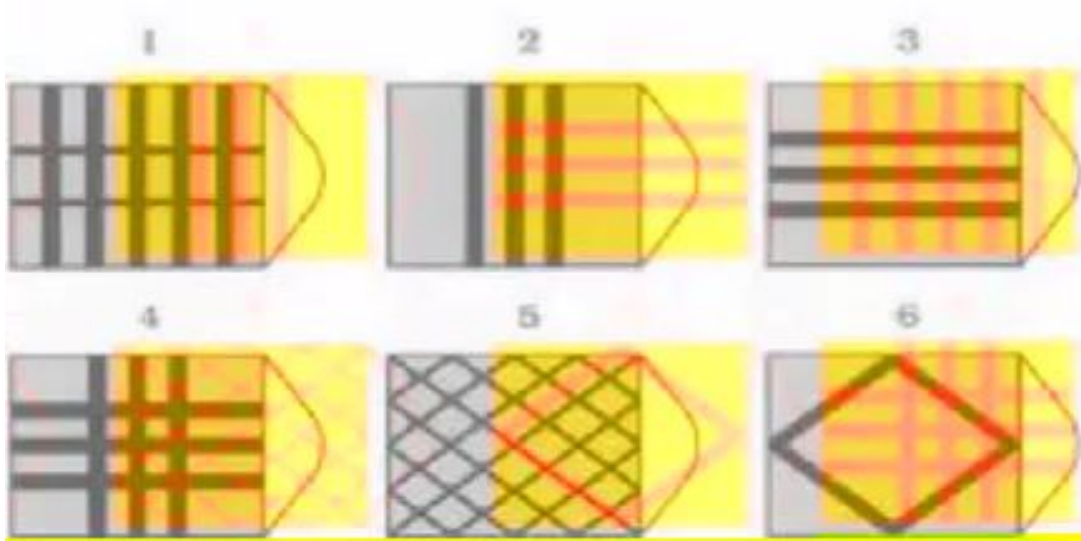
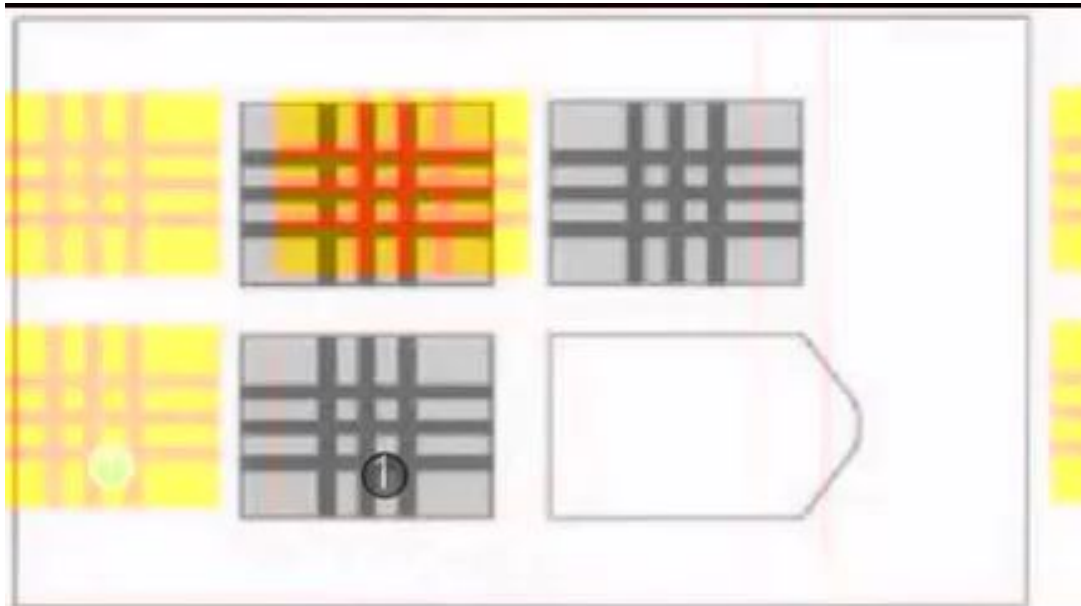

Viewed: 37 / 42
1st Viewed(s): 1.13
Time Viewed: 1.02 s 10 %
Revisitors: 26 / 42
Revisits: 3.73

Name: A01_33
Viewed: 36 / 42
1st Viewed(s): 2.68
Time Viewed: 0.62 s 6 %
Revisitors: 23 / 42
Revisits: 2.48

Viewed: 40 / 42
1st Viewed(s): 1.54
Time Viewed: 0.58 s 6 %
Revisitors: 29 / 42
Revisits: 3.73

Viewed: 41 / 42
1st Viewed(s): 1.67
Time Viewed: 0.99 s 10 %
Revisitors: 36 / 42
Revisits: 3.73

A₁₁

Viewed: 33 / 42
1st Viewed(s): 4.11
Time Viewed: 0.75 s 7 %
Revisitors: 21 / 42
Revisits: 3.73

Viewed: 41 / 42
1st Viewed(s): 1.77
Time Viewed: 0.67 s 7 %
Revisitors: 31 / 42
Revisits: 3.73

Viewed: 15 / 42
1st Viewed(s): 4.79
Time Viewed: 0.24 s 2 %
Revisitors: 7 / 42
Revisits: 3.73

Viewed: 37 / 42
1st Viewed(s): 4.17
Time Viewed: 1.57 s 16 %
Revisitors: 28 / 42
Revisits: 3.73

Viewed: 31 / 42
1st Viewed(s): 2.69
Time Viewed: 0.69 s 7 %
Revisitors: 18 / 42
Revisits: 3.73

Viewed: 13 / 42
1st Viewed(s): 6.45
Time Viewed: 0.36 s 4 %
Revisitors: 2 / 42
Revisits: 3.73



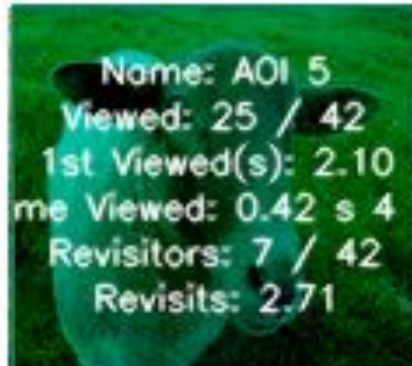



Name: AOI 5
Viewed: 25 / 42
1st Viewed(s): 2.10
Time Viewed: 0.42 s 4
Revisitors: 7 / 42
Revisits: 2.71

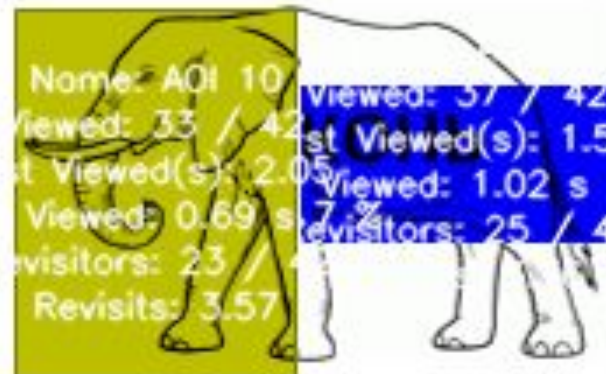

Name: AOI 6
Viewed: 41 / 42
1st Viewed(s): 2.60
Time Viewed: 2.87 s 29
Revisitors: 35 / 42
Revisits: 3.23



Name: AOI 10
Viewed: 33 / 42
1st Viewed(s): 2.05
Time Viewed: 0.69 s 7
Revisitors: 23 / 42
Revisits: 3.57



Viewed: 37 / 42
1st Viewed(s): 1.5
Time Viewed: 1.02 s
Revisitors: 25 / 42



Name: AOI 7
Viewed: 39 / 42
1st Viewed(s): 1.54
Time Viewed: 1.15 s 11
Revisitors: 27 / 42
Revisits: 2.41



Name: AOI 8
Viewed: 35 / 42
1st Viewed(s): 1.54
Time Viewed: 0.53 s 5
Revisitors: 16 / 42
Revisits: 1.63

Name: AOI 11
Viewed: 26 / 42
1st Viewed(s): 2.80
Time Viewed: 0.63 s 6
Revisitors: 16 / 42
Revisits: 1.81

Name: AOI 14
Viewed: 29 / 42
1st Viewed(s): 3.07
Time Viewed: 0.31 s 3
Revisitors: 8 / 42
Revisits: 1.75

Name: AOI 16
Viewed: 31 / 42
1st Viewed(s): 2.23
Time Viewed: 0.65 s 6
Revisitors: 26 / 42
Revisits: 2.96



Name: AOI 12
Viewed: 38 / 42
1st Viewed(s): 3.63
Time Viewed: 1.13 s 11
Revisitors: 21 / 42
Revisits: 2.62

Name: AOI 13
Viewed: 38 / 42
1st Viewed(s): 1.98
Time Viewed: 2.88 s 29
Revisitors: 29 / 42
Revisits: 3.28

Name: AOI 103
Viewed: 38 / 42
1st Viewed(s): 1.81
Time Viewed: 1.00 s 10 %
Revisitors: 27 / 42
Revisits: 2.19

Name: AOI 107
Viewed: 38 / 42
1st Viewed(s): 0.38
Time Viewed: 0.40 s 4 %
Revisitors: 24 / 42
Revisits: 2.42

Name: AOI 104
Viewed: 33 / 42
1st Viewed(s): 2.64
Time Viewed: 0.77 s 8 %
Revisitors: 18 / 42
Revisits: 2.50

Name: AOI 96
Viewed: 31 / 42
1st Viewed(s): 1.79
Time Viewed: 0.87 s 9 %
Revisitors: 21 / 42
Revisits: 1.95

Name: AOI 98
Viewed: 21 / 42
1st Viewed(s): 2.99
Time Viewed: 0.30 s 3 %
Revisitors: 8 / 42
Revisits: 1.88

Name: AOI 95
Viewed: 31 / 42
1st Viewed(s): 2.77
Time Viewed: 0.76 s 8 %
Revisitors: 15 / 42
Revisits: 1.67

Name: AOI 101
Viewed: 42 / 42
1st Viewed(s): 0.75
Time Viewed: 2.26 s 23 %
Revisitors: 40 / 42
Revisits: 3.92

Name: AOI 100
Viewed: 41 / 42
1st Viewed(s): 0.58
Time Viewed: 2.37 s 24 %
Revisitors: 38 / 42
Revisits: 3.32

Name: AOI 102
Viewed: 41 / 42
1st Viewed(s): 2.66
Time Viewed: 2.40 s 24 %
Revisitors: 39 / 42
Revisits: 2.51

Name: AOI 105
Viewed: 10 / 42
1st Viewed(s): 5.51
Time Viewed: 0.03 s 0 %
Revisitors: 0 / 42
Revisits: 0.00

Name: AOI 106
Viewed: 31 / 42
1st Viewed(s): 3.44
Time Viewed: 0.82 s 8 %
Revisitors: 21 / 42
Revisits: 1.62

Name: AOI 97
Viewed: 36 / 42
1st Viewed(s): 1.75
Time Viewed: 0.98 s 10 %
Revisitors: 24 / 42
Revisits: 1.71

Name: AOI 99
Viewed: 10 / 42
1st Viewed(s): 3.53
Time Viewed: 0.03 s 0 %
Revisitors: 2 / 42
Revisits: 1.50

Name: AOI 94
Viewed: 41 / 42
1st Viewed(s): 1.76
Time Viewed: 2.83 s 26 %
Revisitors: 33 / 42
Revisits: 3.21

Name: AOI 89
Viewed: 33 / 42
1st Viewed(s): 1.64
Time Viewed: 0.90 s 9 %
Revisitors: 21 / 42
Revisits: 2.19

Name: AOI 92
Viewed: 22 / 42
1st Viewed(s): 1.94
Time Viewed: 0.37 s 4 %
Revisitors: 9 / 42
Revisits: 2.11

Name: AOI 90
Viewed: 31 / 42
1st Viewed(s): 1.52
Time Viewed: 0.65 s 7 %
Revisitors: 16 / 42
Revisits: 1.88

Name: AOI 86
Viewed: 29 / 42
1st Viewed(s): 1.91
Time Viewed: 0.60 s 6 %
Revisitors: 13 / 42
Revisits: 2.08

Name: AOI 84
Viewed: 27 / 42
1st Viewed(s): 2.60
Time Viewed: 1.01 s 10 %
Revisitors: 9 / 42
Revisits: 3.33

Name: AOI 87
Viewed: 38 / 42
1st Viewed(s): 0.83
Time Viewed: 1.10 s 11 %
Revisitors: 25 / 42
Revisits: 2.44

Name: AOI 82
Viewed: 39 / 42
1st Viewed(s): 0.99
Time Viewed: 1.05 s 10 %
Revisitors: 22 / 42
Revisits: 3.05

Name: AOI 88
Viewed: 41 / 42
1st Viewed(s): 1.55
Time Viewed: 4.42 s 44 %
Revisitors: 34 / 42
Revisits: 2.62

Name: AOI 93
Viewed: 13 / 42
1st Viewed(s): 4.70
Time Viewed: 0.31 s 3 %
Revisitors: 4 / 42
Revisits: 4.00

Name: AOI 91
Viewed: 35 / 42
1st Viewed(s): 1.54
Time Viewed: 0.76 s 8 %
Revisitors: 17 / 42
Revisits: 1.59

Name: AOI 85
Viewed: 38 / 42
1st Viewed(s): 1.13
Time Viewed: 0.71 s 7 %
Revisitors: 21 / 42
Revisits: 1.43

Name: AOI 83
Viewed: 40 / 42
1st Viewed(s): 1.43
Time Viewed: 4.65 s 47 %
Revisitors: 30 / 42
Revisits: 3.03

красный

красный

красный

красный

синий

синий

синий

синий

красивый

Name: AOI 108
Viewed: 27 / 28
1st Viewed(s): 0.95
Time Viewed: 1.07 s 11 %
Revisitors: 22 / 28
Revisits: 2.50

красивый

Name: AOI 109
Viewed: 28 / 28
1st Viewed(s): 0.91
Time Viewed: 1.24 s 12 %
Revisitors: 26 / 28
Revisits: 3.69

Name: AOI 106
Viewed: 28 / 28
1st Viewed(s): 1.17
Time Viewed: 3.67 s 37 %
Revisitors: 28 / 28
Revisits: 5.71

красивый

Name: AOI 110
Viewed: 28 / 28
1st Viewed(s): 1.57
Time Viewed: 1.11 s 11 %
Revisitors: 22 / 28
Revisits: 2.77

Стиль

Name: AOI 113
Viewed: 27 / 28
1st Viewed(s): 1.29
Time Viewed: 0.91 s 9 %
Revisitors: 15 / 28
Revisits: 3.47

Стиль

Name: AOI 112
Viewed: 27 / 28
1st Viewed(s): 0.78
Time Viewed: 1.60 s 16 %
Revisitors: 27 / 28
Revisits: 4.56

Стиль

Name: AOI 111
Viewed: 28 / 28
1st Viewed(s): 0.64
Time Viewed: 4.08 s 41 %
Revisitors: 27 / 28
Revisits: 5.48

Стиль

Name: AOI 115
Viewed: 23 / 28
1st Viewed(s): 1.45
Time Viewed: 1.27 s 13 %
Revisitors: 18 / 28
Revisits: 1.89

Д л и н н ы й
Viewed: 40 / 42
1st Viewed(s): 0.66
Time Viewed: 2.15 s 22 %
Revisitors: 40 / 42 Name: AOL 52

к о р о т к и й
Viewed: 33 / 42
1st Viewed(s): 2.04
Time Viewed: 1.08 s 11 %
Revisitors: 31 / 42

Viewed: 40 / 42
1st Viewed(s): 1.50
Time Viewed: 0.59 s 6 %
Revisitors: 30 / 42

к о р о т к и й
1st Viewed(s): 2.51
Time Viewed: 0.84 s 8 %
Revisitors: 33 / 42

д л и н н ы й
1st Viewed(s): 1.91
Time Viewed: 0.88 s 9 %
Revisitors: 36 / 42

Viewed: 39 / 42
1st Viewed(s): 0.99
Time Viewed: 0.74 s 7 %
Revisitors: 30 / 42

Viewed: 35 / 42
1st Viewed(s): 2.78
Time Viewed: 0.58 s 6 %
Revisitors: 24 / 42

Name: AOL 19
Viewed: 40 / 42
1st Viewed(s): 2.34
Time Viewed: 0.97 s 10 %
Revisitors: 34 / 42
Revisits: 2.65

Name: AOL 22
Viewed: 42 / 42
1st Viewed(s): 2.46
Time Viewed: 1.15 s 11 %
Revisitors: 35 / 42
Revisits: 3.17

Viewed: 34 / 42
1st Viewed(s): 2.57
Time Viewed: 0.72 s 7 %
Revisitors: 30 / 42

Viewed: 38 / 42
1st Viewed(s): 4.10
Time Viewed: 0.46 s 5 %
Name: AOL 24
Revisitors: 26 / 42

Viewed: 34 / 42
1st Viewed(s): 2.34
Time Viewed: 0.99 s 10 %
Revisitors: 29 / 42

Viewed: 34 / 42
1st Viewed(s): 4.81
Time Viewed: 0.70 s 7 %
Revisitors: 22 / 42

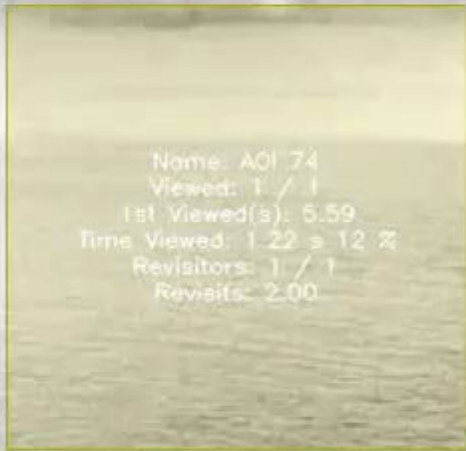

Name: AOI 74
Viewed: 1 / 1
1st Viewed(s): 5.59
Time Viewed: 1.22 s 12 %
Revisitors: 1 / 1
Revisits: 2.00



Name: AOI 97
Viewed: 1 / 1
1st Viewed(s): 0.74
Time Viewed: 2.57 s 26 %
Revisitors: 1 / 1
Revisits: 4.00



Name: AOI 93
Viewed: 1 / 1
1st Viewed(s): 0.00
Time Viewed: 4.06 s 41 %
Revisitors: 1 / 1
Revisits: 5.00

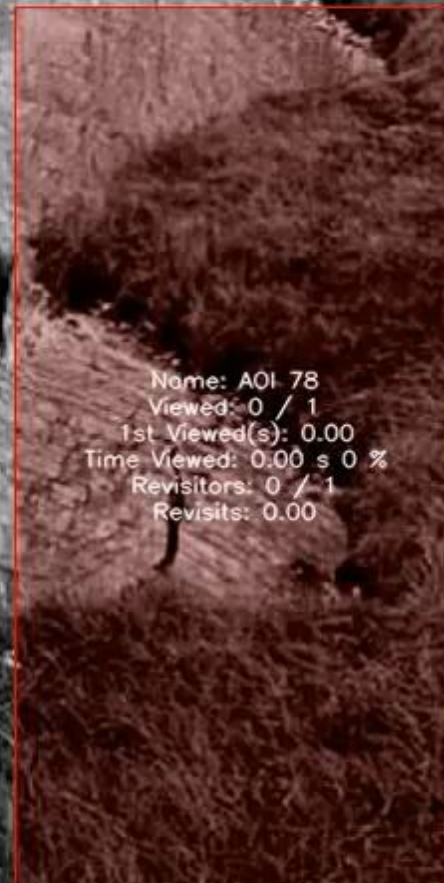

Name: AOI 78
Viewed: 0 / 1
1st Viewed(s): 0.00
Time Viewed: 0.00 s 0 %
Revisitors: 0 / 1
Revisits: 0.00



Name: AOI 84
Viewed: 0 / 1
1st Viewed(s): 0.00
Time Viewed: 0.00 s 0 %
Revisitors: 0 / 1
Revisits: 0.00

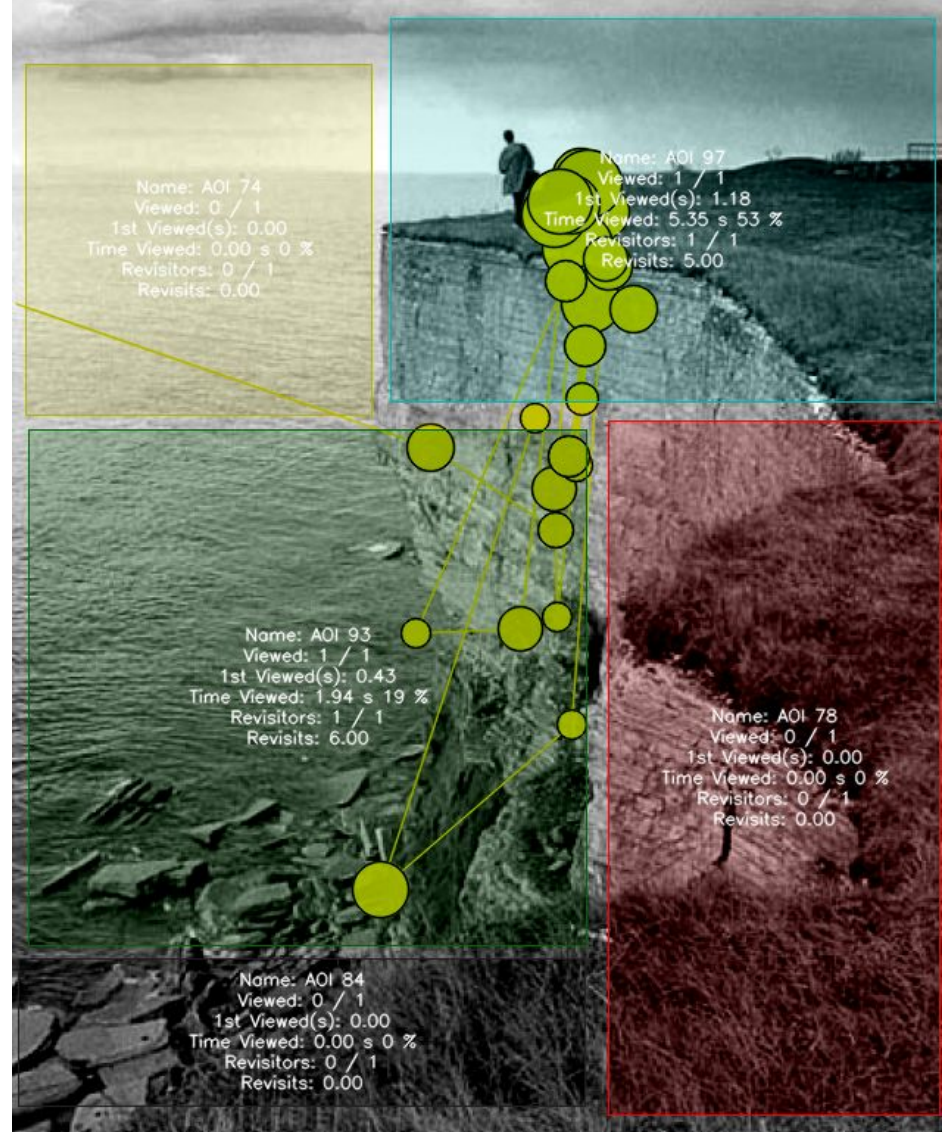
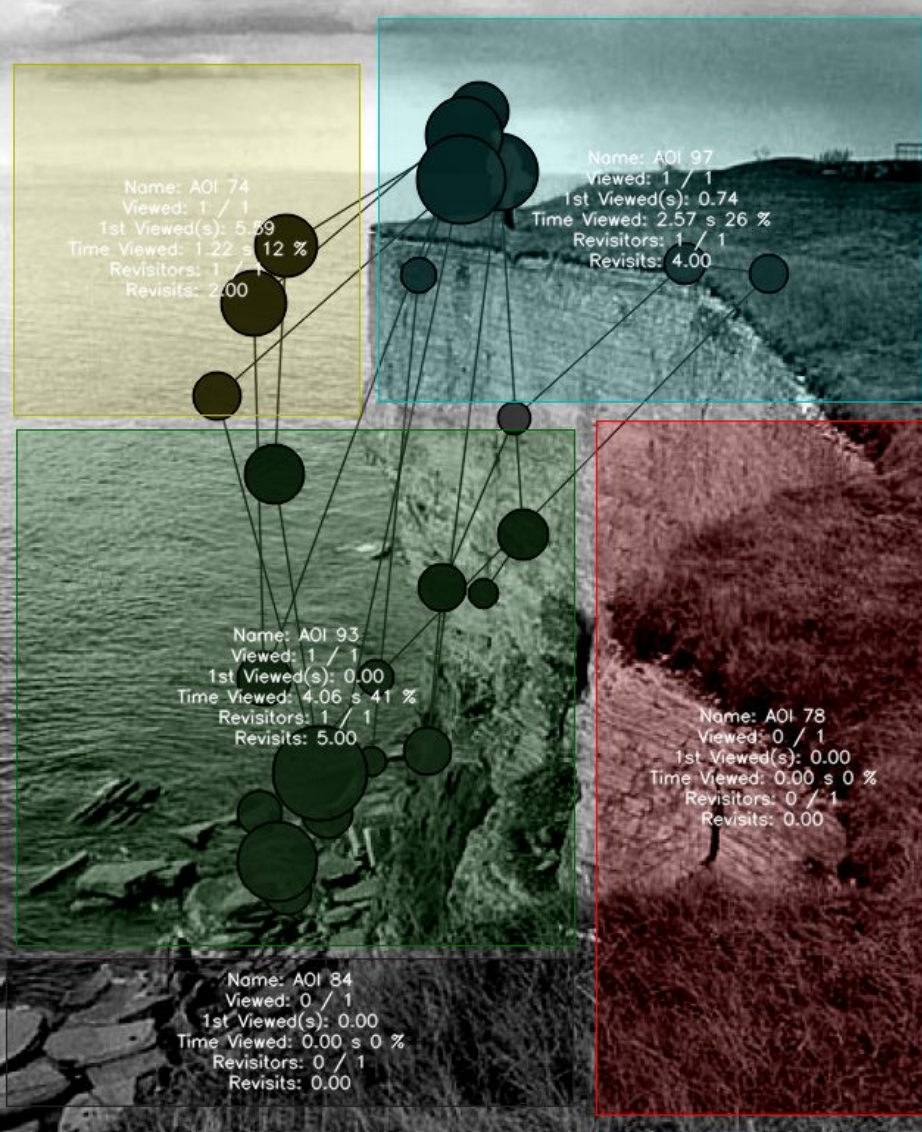



Раздел 2. Что изменит?



Раздел 3. Главные ориентиры

- Обозначьте 3 наиболее для Вас важных изменения в ближайшие 3-5 лет
- Сформулируйте 3-6 наиважнейших цели на ближайшие 3-6 месяцев
- Какие ценности они отражают? Что наполняет их смыслом? Что и почему в результате их реализации для Вас и Ваших близких изменится к лучшему?

- По шкале от 1 до 10 оцените степень их:
 - сложности
 - злободневности
 - влияния на качество Вашей жизни

- По шкале от 1 до 10 оцените степень их соответствия шкалам SMART -теста

SMART- анализ

- **S** – (specific) – конкретность
- **M** – (measurable) – измеримость (наличие проверяемых конечных показателей)
- **A** (agreeable) – приемлемость (наличие согласия заинтересованных сторон)
- **R** – (realistic) – реалистичность (определяется на основе внутренней и внешней среды организации- SWOT анализ)
- **T**- (time bound) – определенность сроков реализации

Чего хочет большинство
людей?

- Что иметь?

- Что делать, чем заниматься?

- Кем быть?

16 наиболее распространённых желаний

1. Влиять. 2. Быть независимым. 3. Получать одобрение.

4. Знать истину. 5. Соблюдать традиции, сохранять связь с корнями, следовать избранному «кодексу чести».

6. Накапливать и сохранять. 7. Упорядочить.

8. Справедливости. 9. Конкурентоспособности.

10. Дружить. 11. Престижа, общественного положения.

12. Сытости. 13. Физическое здоровье, способность к полноценной физической активности.

14. Счастливой семейной жизни. 15. Романтических отношений. 16. Душевного равновесия.

Персональные предпочтения

крепкое
здоровье

МОЯ
мечта

счастливая
семья

высокая
зарплата

работа,
карьера

слава,
успех

крепкое
здоровье

Я

счастливая
семья

высокая
зарплата

работа,
карьера

слава,
успех



крепкое
здоровье



счастливая
семья

высокая
зарплата

работа,
карьера

слава,
успех

Групповые предпочтения

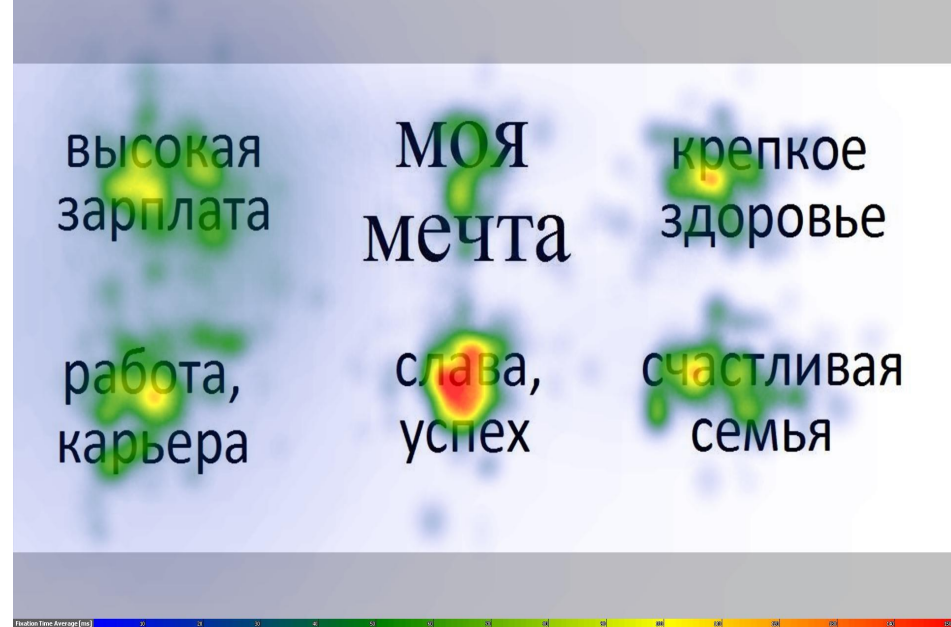

«Колесо жизненного баланса»





ДЕРЕВО ЖИЗНЕННО ВАЖНЫХ ЦЕЛЕЙ

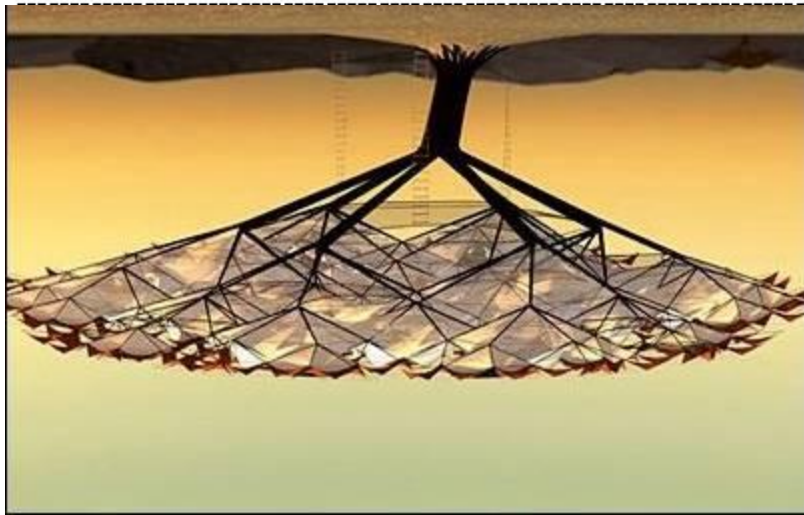
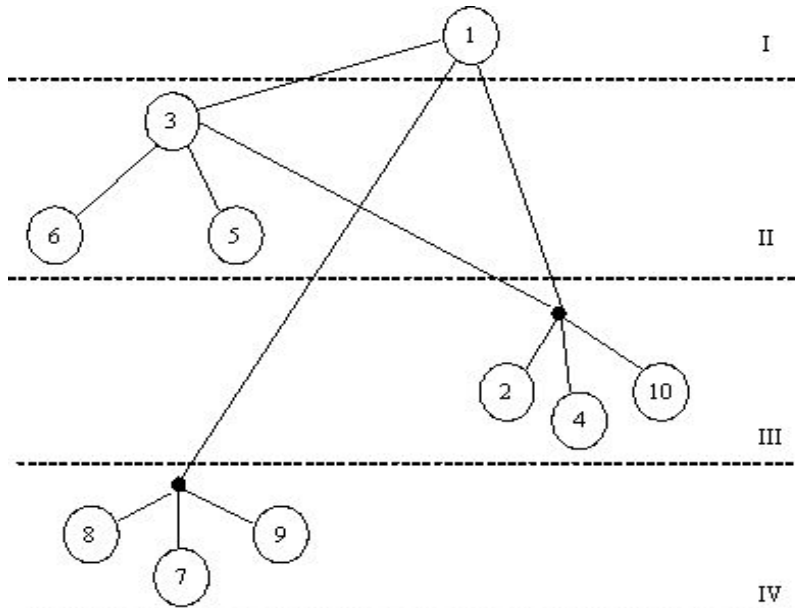

Раздел 4.1. Мой выбор

- Чего хочу Я на самом деле?
- Как выглядит мое колесо баланса («дерево») жизненно важных целей?

- То, что Вы наметили, ДОСЛОВНО соответствует тому, что Вы хотите получить? Именно это РЕАЛЬНО нужно?

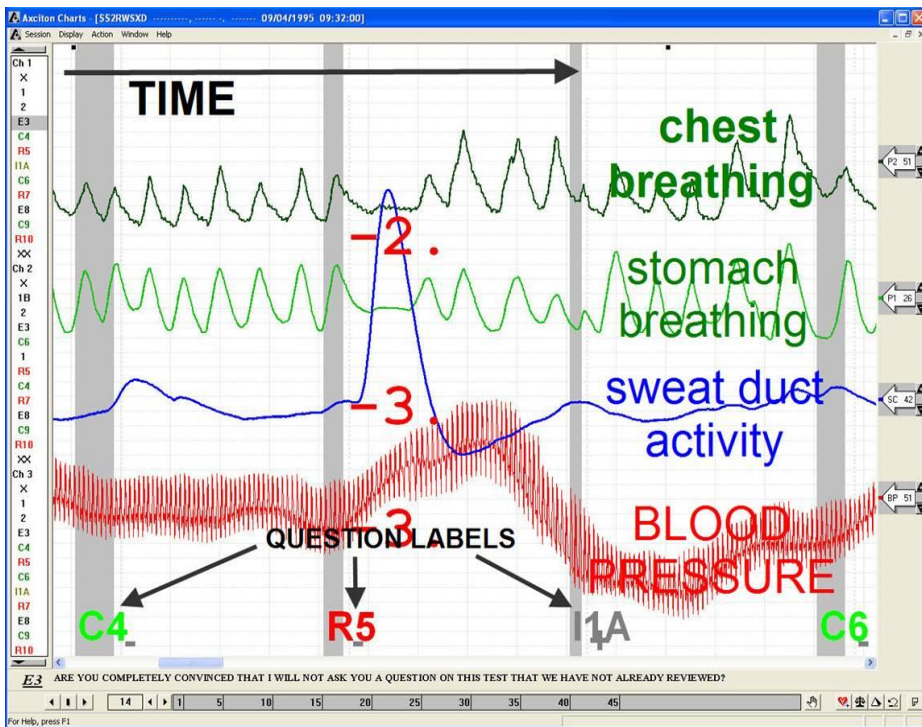

5. Критерии стратегического выбора

Наполнено смыслом

Доставляет
удовольствие

Увлекает

Укрепляет
отношения

Хороший
прецедент



6. Критерии оперативного выбора

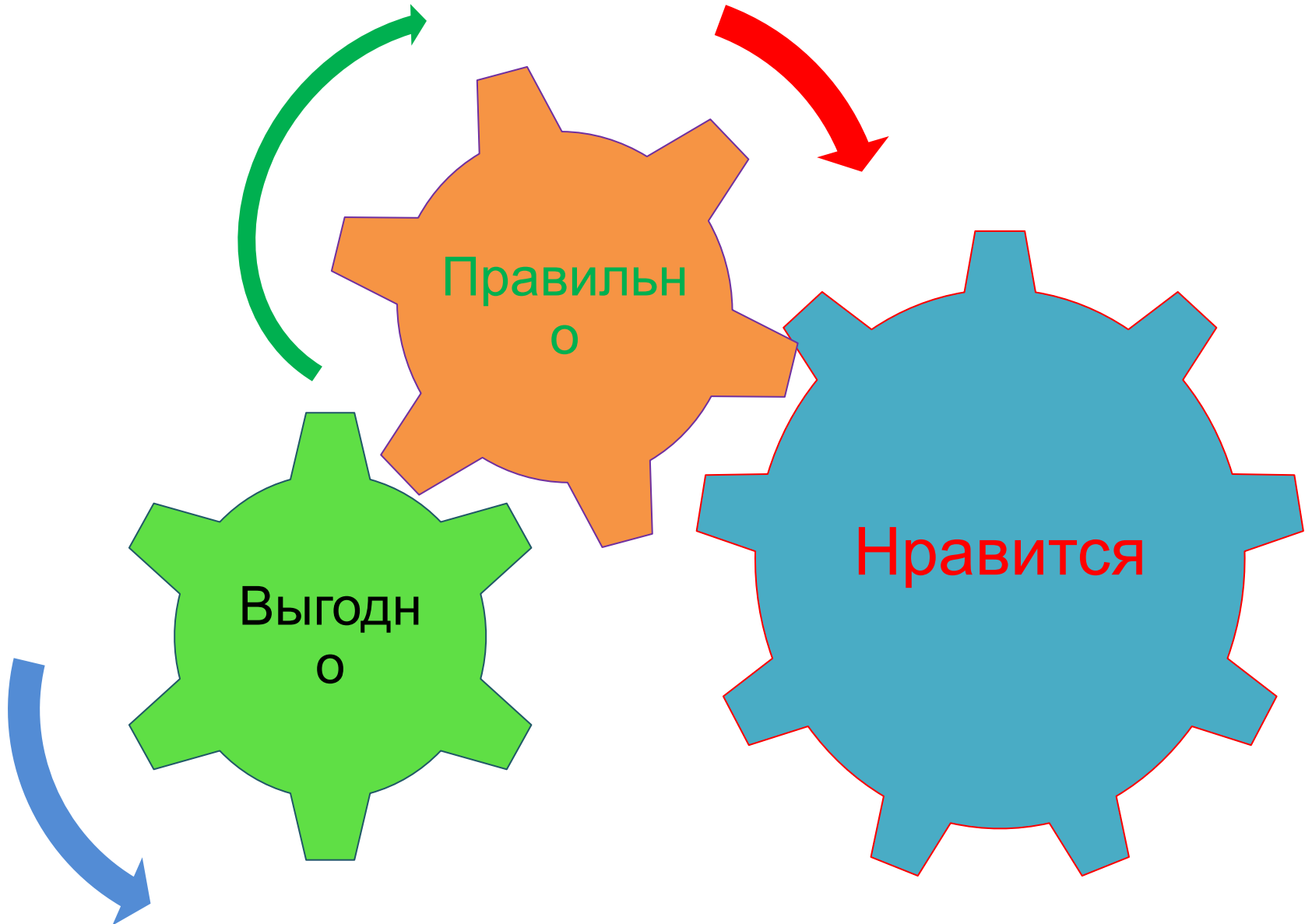

8. Ключевые факторы

Семья

Друзья

Школа
Вуз
Работа

**Персональные
увлечения**

Раздел 4.2. Мой выбор

- Чего хочу Я на самом деле?
- Как выглядит мое колесо баланса («дерево») жизненно важных целей?

Чего хочу Я? Из чего
складывается мой жизненный
успех, счастье, благополучие,
процветание?

Что хочу иметь?

Чем заниматься?

Кем стать,

быть

и оставаться?

БЛАГОДАРЮ

ЗА

ВНИМАНИЕ!