

# Rotordynamics

S 8-1



# Introduction

- Main Focus: Jet Engines
- Funding provided by NASA/Boeing, GE, MTU, P&W, Snecma and Rolls-Royce and new participants, Embraer, Honeywell and University of Virginia
- Three phase implementation
  - Phase I – Version 2004+
  - Phase II and Consortium – Version 2005r3
  - Phase II – Version 2006r1
  - Phase II+ - Version 2006r2...

# Overview of Rotordynamics

- Types of analyses
  - Static analysis
  - Complex Eigenvalue
    - Whirl modes, Campbell diagrams
    - Critical speed prediction
  - Frequency response
  - Transient (Linear and Nonlinear) response
- Dynamic solution usually needed for most rotordynamic analyses, e.g., unbalance rotor response, critical speed analysis.
- Special cases solved with static analysis, e.g., aircraft in a steady turn

# Overview of Rotordynamics

- Assumptions and Limitations
  - Analysis performed in a stationary (inertial) coordinate system, i.e., non-rotating
  - Models must be axi-symmetric, e.g, cyclic symmetric with 3 or more segments
  - Center-line model, rotor grids must be on the center-line
    - Use static condensation for 3D models
  - Connect rotor models to support structure by rigid elements only, elastic coupling at the g-set is not allowed

# Overview of Rotordynamics

- Assumptions and Limitations
  - Rotor axis is flexible, disks are rigid
  - Critical speeds and modes are only available for the reference rotor
  - Modes valid between SPDLOW and SPDHIGH specified on RGYRO entry
  - Data recovery of secondary quantities (force, stress) is not correct in the rotor in the presence of rotor damping

# Multiple Rotors & the Reference Rotor

- For frequency response and static analysis a reference rotor must be specified
- Analyses are performed with the reference rotor spinning at a specified speed
- Spin rates of other rotors are determined by means of user specified relationships between the rotor spin rates (RSPINR)

# Multiple Rotors & the Reference Rotor

- Synchronous frequency-domain (complex modes and frequency response) analyses are performed relative to the reference rotor
- The reference rotor spins at the excitation frequency, or for complex modes, at the eigen frequency
- Results are interpreted in terms of the reference rotor

# Input Overview





# Bulk Data

Table of Rotordynamic Entries versus Analysis Discipline

Entry	Static	Complex Eigenvalue	Frequency Response	Transient Response
ROTORG	*	*	*	*
RGYRO	*	*	*	
RSPINR	*	*	*	
RSPINT				*
UNBALNC			* (optional)	* (optional)
ROTORSE	*	*	*	*

# Bulk Data

- RGYRO - specifies the reference rotor ID and rotation speed and synchronous or asynchronous analysis

Format:

RGYRO	RID	SYNCFLG	REFROTR	SPDUNIT	SPDLOW	SPDHIGH	SPEED		
-------	-----	---------	---------	---------	--------	---------	-------	--	--

Example:

RGYRO	100	ASync	1	RPM			2000.		
-------	-----	-------	---	-----	--	--	-------	--	--

# Bulk Data

- ROTORG – specifies the grid points of the rotor line model

Format.

ROTORID	GRID1	GRID2	GRID3	...	GRIDn			
---------	-------	-------	-------	-----	-------	--	--	--

or

ROTORG	ROTORID	GRID1	THRU	GRID2	BY	Inc			
--------	---------	-------	------	-------	----	-----	--	--	--

Example:

ROTORG	1	1	THRU	101	BY	10			
--------	---	---	------	-----	----	----	--	--	--

# ROTORG Contents

ROTORID Identification number for rotor

GRIDi Grids comprising the rotor

THRU Specifies a range of identification numbers

BY Specifies an increment for a THRU specification

INC Increment for THRU range

# Rotor & Support Structure Connection

- Rotors specified using the ROTORG must employ rigid elements to decouple support structure
  - Otherwise, incorrect gyroscopic terms
- Rotors specified using the ROTORSE entry can be connected directly to the support structure



# Rotor & Support Structure Connection

- Schematic Example of Connection when using ROTORG Support Structure

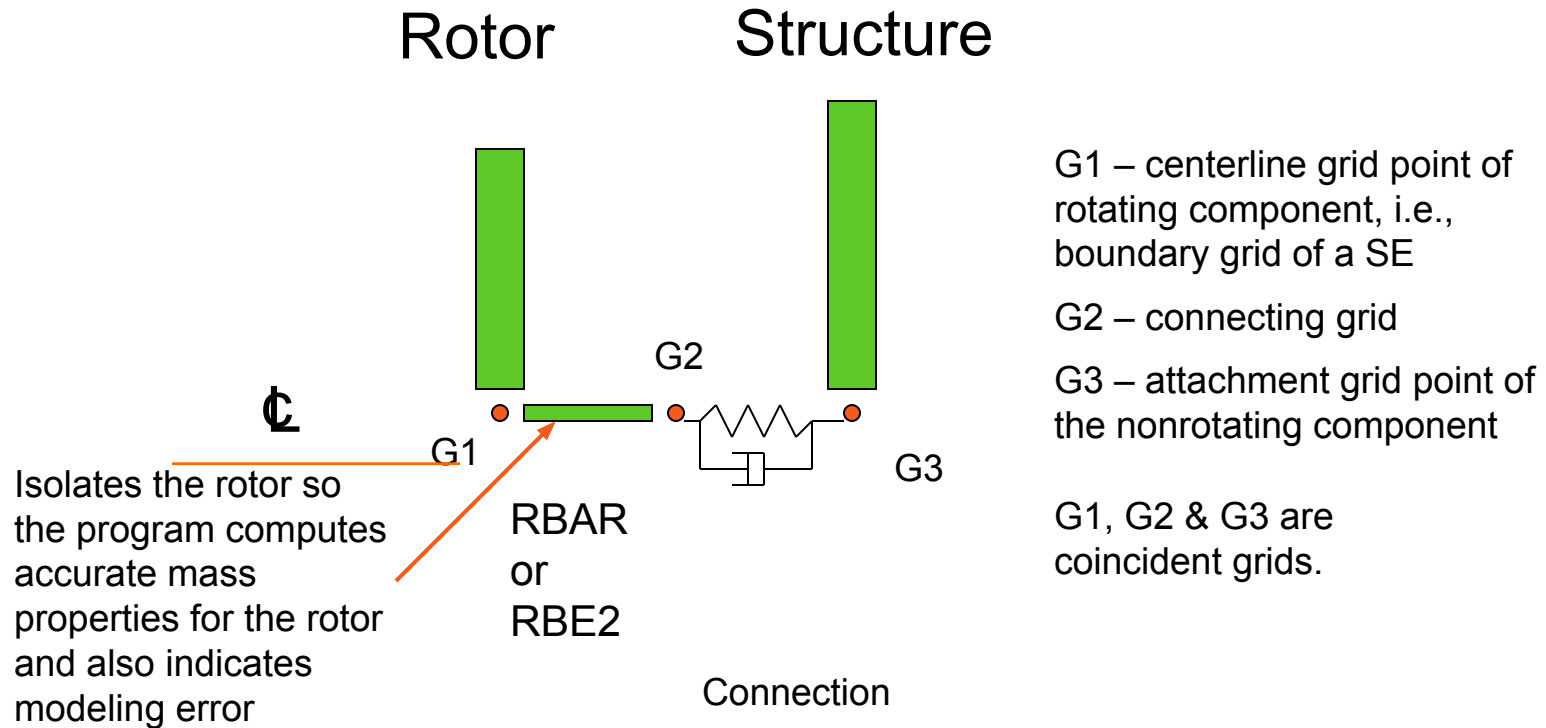

- G2 & RBAR/RBE2 not needed with ROTORSE

# Remarks

- Proper Rotor/Structure Connection avoids adding miscellaneous mass to the rotor and circulation damping terms caused by support structure stiffness.
- Note that the dependent/independent dofs of the RBAR or RBE2 does not matter since the rotor mass and circulation damping are based on the g-set dofs.
- ROTORSE changes the above rules



# Bulk Data

- ROTORSE Specifies grids that compose the rotor line model
  - The boundary grids for a rotor specified with the ROTORSE in place of the ROTORG must still follow the same rules as the ROTORG input.
- Format:

• Example

ROTORS E	ROTORI D	SEID	SEOPT						
ROTORS E	10	1							

S 8-16



# Bulk Data

- RSPINR - specifies the relative spin rates between rotors for complex eigenvalue, frequency response, and static analysis
  - Also defines positive rotor spin direction (GA to GB)

Format:

RSPINR	ROTORID	GRIDA	GRIDb	SPDUNIT	SPTID				
Example:	GR	ALPHAR1	ALPHAR2	HYBRID					

RSPINR	100	1001	1002	RPM	100				
	0.02			1001					

\* Format for 2004 to 2005r2, changed 2005r3

# RSPINR Contents

**ROTORID** Identification number of rotor

**GRIDA/GRIDB** Positive rotor spin direction defined from GRIDA to GRIDB

**GR** Rotor structural damping factor

**SPDUNIT** Specifies whether the listing of relative spin rates is given in terms of RPM or frequency

**SPEED** List of relative spin rates, entries for reference rotor must be in ascending or descending order

# Bulk Data

- RSPINT - specifies rotor spin rates for transient analysis
  - Also defines positive rotor spin direction (GA to GB)

Format:

RSPINT	ROTORID	GRIDA	GRIDB	SPDUNIT	SPTID	SPDOUT			
	GR	ALPHAR1	ALPHAR2	HYBRID					

Example:

RSPINT	100	1001	1002	RPM	1001				
	0.02	0.01	0.002						

# RSPINT Contents

**ROTORID** Identification number of rotor

**GRIDA/GRIDB** Positive rotor spin direction is defined from GRIDA to GRIDB

**GR** Rotor structural damping factor

**SPDUNIT** Specifies whether the spin rates are given in terms of RPM or frequency

**TID** Identification of TABLEDi entry specifying spin rate versus time

# Bulk Data

- UNBALNC—specifies unbalance load for transient or frequency response analysis defined in a cylindrical coordinate system with the rotor rotational axis as the z-axis

Format:

UNBALNC	RID	MASS	GRID	X1	X2	X3			
	ROFFSET	THETA	ZOFFSET	Ton	Toff	CFLAG			
	UFT1	UFT2	UFT3	UFR1	UFR2	UFR3			
	MCT1	MCT2	MCT3	MCR1	MCR2	MCR3			
Example:	SCR1	SCR2	SCR2						

UNBALNC	100	.1	1001	0.0	1.0	0.0			
	0.02	30.0	0.5			-1			

# UNBALNC Contents

- RID Identification number of UNBALNC entry. Selected by Case Control command, RGYRO
- MASS Mass imbalance
- GRID Grid identification number of applying imbalance. The grid must appear on a ROTORG entry
- X1, X2, X3 Components of the vector from GRID in the displacement coordinate of GRID which is used to define a cylindrical coordinate system centered at GRID
- ROFFSET Offset of mass in the radial direction of the unbalance coordinate system
- THETA Angular position of the mass in the unbalance coordinate system
- ZOFFSET Offset of mass in the z-direction of the unbalance coordinate system
- Ton Start time for applying imbalance load
- Toff Time for terminating imbalance load

# UNBALNC Contents (cont.)

CFLAG Correct flag to specify whether 1) the mass will be used to modify the total mass in the transient response calculations, 2) the effect of the rotor spin rate change will be included in the transient response calculation or 3) both

UFT1-3\* EPOINTS to output the unbalanced forces in T1, T2 and T3 directions

UFR1-3\* EPOINTS to output the unbalanced forces in R1, R2 and R3 directions

MCT1-3\* EPOINTS to output the mass correction forces in T1, T2 and T3 directions

MCR1-3\* EPOINTS to output the mass correction forces in R1, R2 and R3 directions

SCR1-3\* EPOINTS to output the speed-correction forces for the R1, R2 and R3 directions

## Description of MASS Unbalance

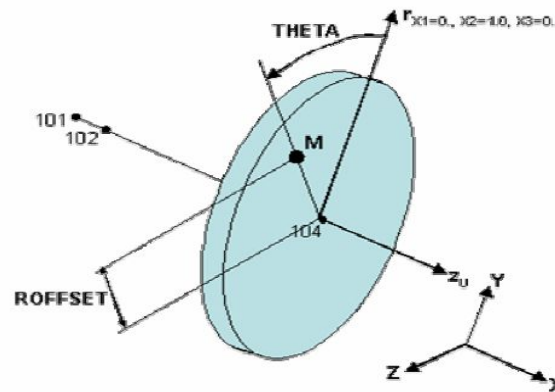

\* Supported in 2005r3

S 8-23

# User Parameters

- Four parameters added for the rotor dynamics capability
  - PARAM,GYROAVG,x (default=0)
    - If  $x=-1$ , the gyroscopic terms are generated using a least square fit of terms within the analysis range
  - PARAM,WR3,x; PARAM,WR4,z, and PARAM,WRH,z
    - Specifies “average” excitation for calculation of rotor damping and circulation terms
    - This is similar to param,w3,y and param,w4,z in transient analysis





# Some Applications of Rotordynamics

# The Dimentberg Rotor\*

$$M_d = 0.0157 \text{ kg sec}^2/\text{cm}$$

$$I_d = 2.45 \text{ kg/sec}^2 \text{ cm}$$

$$I_p = 2 I_d$$

$$EI = 1,647,700 \text{ kg cm}^2$$

$$\Omega = 100 \text{ rad/sec}$$

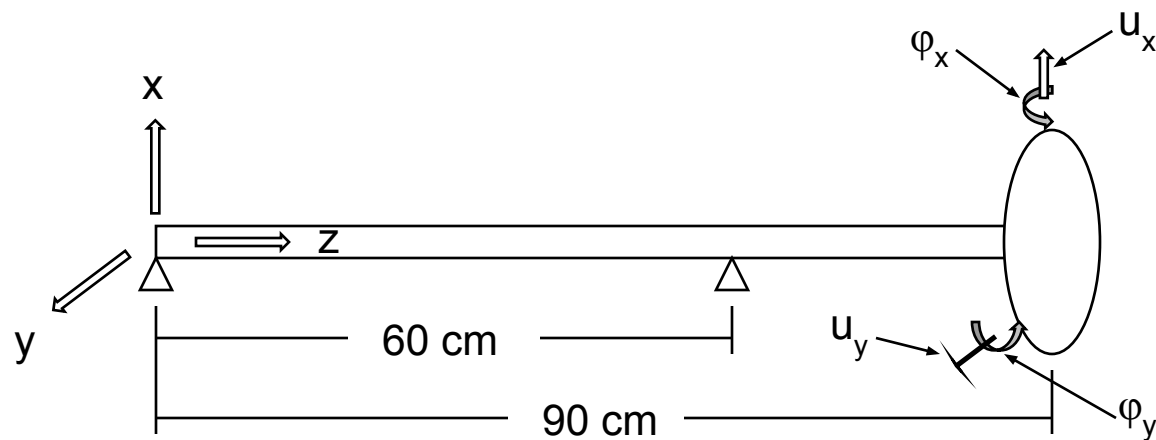

\*References:

Bedrossian, H., and Viekos, N., Rotor-Disk System Gyroscopic Effects in MSC/NASTRAN Dynamics Solutions, MSC/NASTRAN User's Conf. Proc., Paper No. 12, 1982.

Dimentberg, F. M., Flexural Vibrations of Rotating Shafts, Butterworths, London, 1964

# Line Model w/o Superelements

- CBAR Elements with CONM2 100 at Node 10

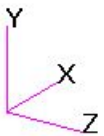
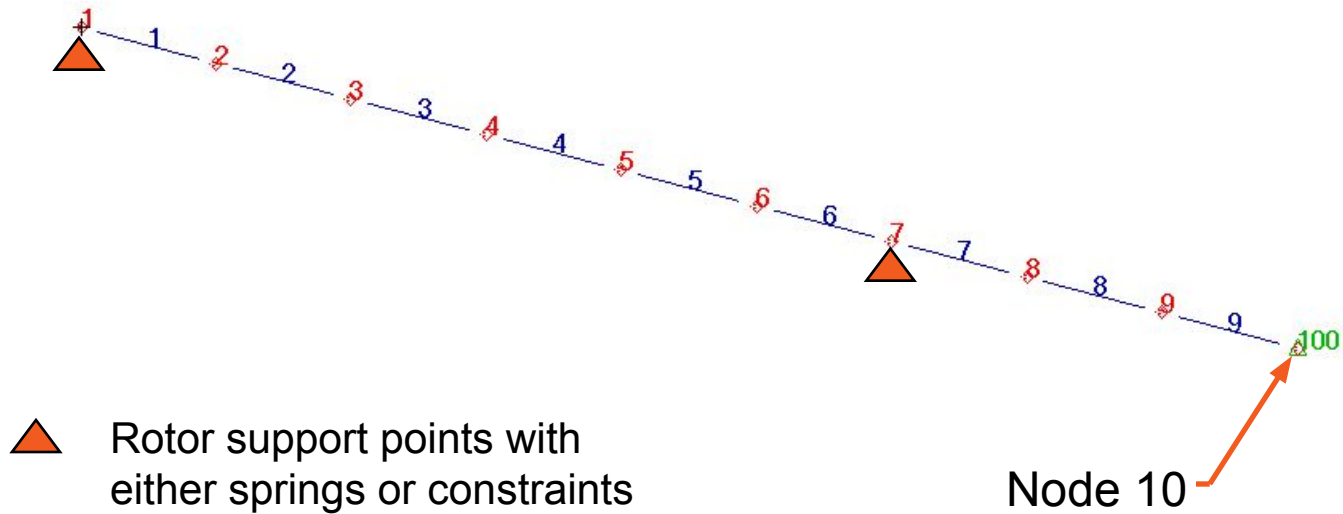

# The Dimentberg Rotor

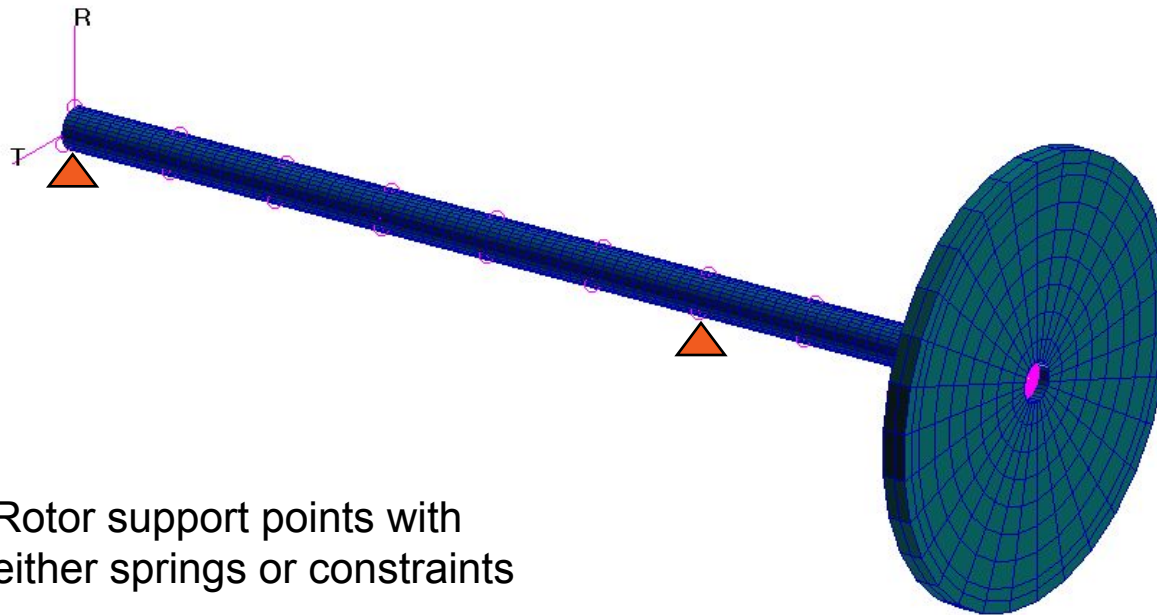

▲ Rotor support points with either springs or constraints

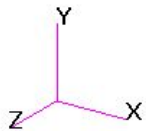

# Comments

- Proper Rotor/Structure Connection avoids adding miscellaneous mass to the rotor and circulation damping terms caused by support structure stiffness.
- Note that the dependent/independent dofs of the RBAR or RBE2 does not matter since the rotor mass and circulation damping are based on the g-set dofs.



# Connection for Rotor and Support Structure

- Schematic Example of Connection

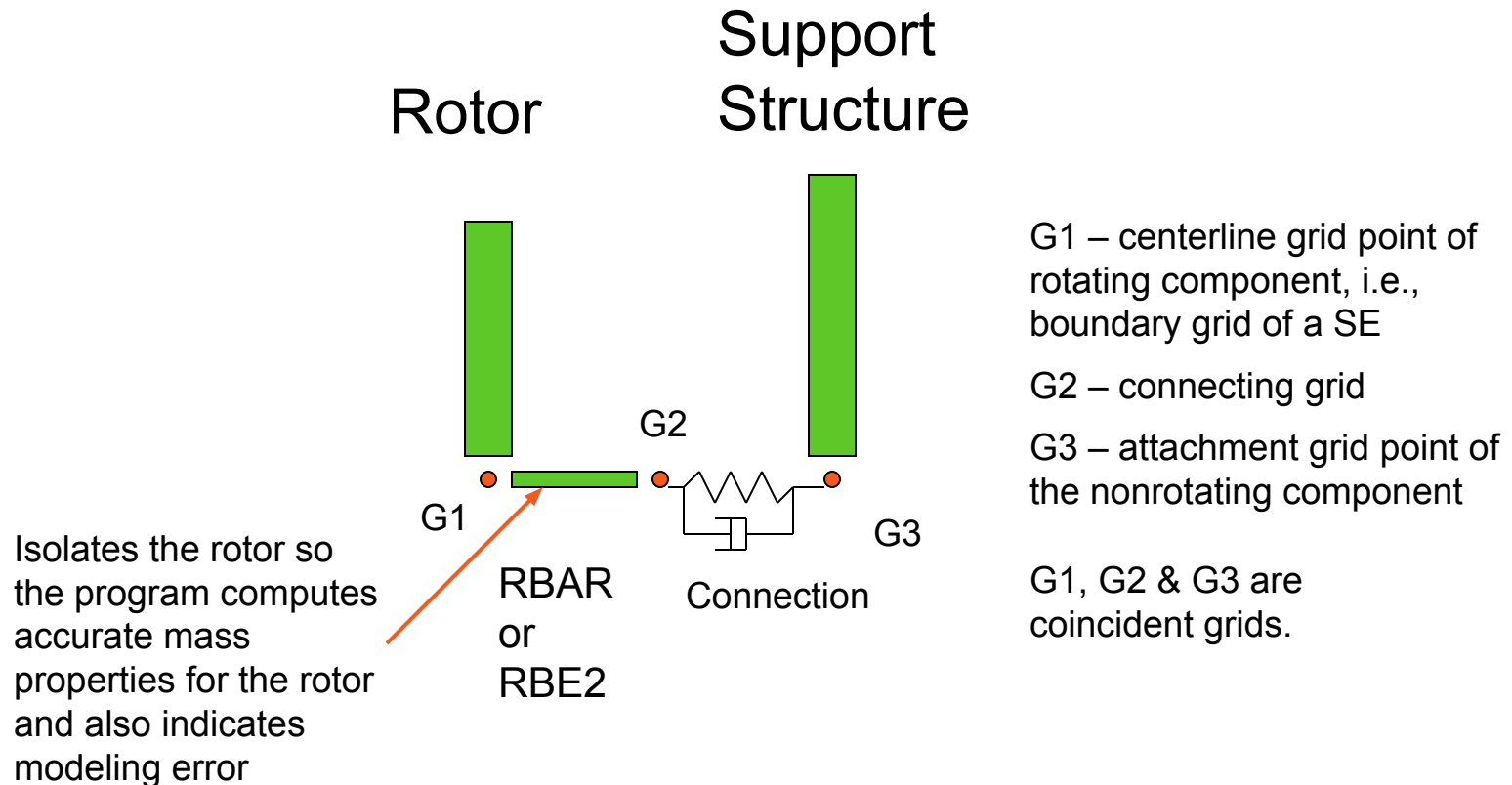

# Bulk Data

- ROTORSE Specifies grids that compose the rotor line model
  - The boundary grids for a rotor specified with the ROTORSE in place of the ROTORG must still follow the same rules as the ROTORG input.
- Format:

• Example

ROTORS E	ROTORI D	SEID	SEOPT						
ROTORS E	10	1							

S 8-31

# Rotordynamics

- Complex Eigenvalue Analyses
  - Whirl Frequencies
  - Critical Speeds
- Frequency Response
- Nonlinear Transient





# Whirl Modes



# Input File

```
ID ROTATING DISK
SOL 107
CEND
TITLE = GYROSCOPIC INFLUENCE OF A RIGID DISK ROTATING ON A SHAFT
SUBTI = NEARLY MASSLESS SHAFT, SPIN RATE OF 100.0 RAD/SEC
  SPC
  RGYRO
  CMETHOD
  DISP(PHASE) = ALL
BEGIN BULK
.
$ DISK MASS AND GYRO SPECIFICATIONS
CONM2 100 10 157.0-4
      2.45 2.45 4.9
$ GYROSCOPIC COUPLING AND SPEED CONTROL
$rotorg  rotorid  gid1 gid2 etc
ROTORG  1 1 thru 10 by 1
$rgyro  rid  syncflg  refrotr  spdunit  spdlow  spdhigh  speed
RGYRO 1 1 1 RPM 954.93
$rspinr  rotorid  grida gridb gr  spdunit  speed1  speed2  etc.
RSPINR  1 9 10 RPM 954.93
$ COMPLEX EIGENVALUE EXTRACTION
EIGC 1 HESS MAX 8
ENDDATA
```

Note: Multiple SUBCASEs are allowed to run different speeds on the selected RGYRO entry

Note:  $I_p$  is required on the CONM2

Combined to compute  $\Omega_p$

Keeps rotor spin speed constant



# Results

C O M P L E X   E I G E N V A L U E   S U M M A R Y					
ROOT	EXTRACTION	EIGENVALUE		FREQUENCY	DAMPING
NO.	ORDER	(REAL)	(IMAG)	(CYCLES)	COEFFICIENT
1	2	7.204462E-15	-3.805280E+01	6.056291E+00	-3.786561E-16
2	1	7.204462E-15	3.805280E+01	6.056291E+00	-3.786561E-16
3	4	-2.242220E-14	-7.656962E+01	1.218643E+01	5.856683E-16
4	3	-2.242220E-14	7.656962E+01	1.218643E+01	5.856683E-16
5	6	4.939756E-14	-2.423585E+02	3.857254E+01	-4.076405E-16
6	5	4.939756E-14	2.423585E+02	3.857254E+01	-4.076405E-16
7	8	2.961827E-14	-4.038409E+02	6.427328E+01	-1.466829E-16
8	7	2.961827E-14	4.038409E+02	6.427328E+01	-1.466829E-16



# Campbell Model for non-SE Model

## Natural Frequencies

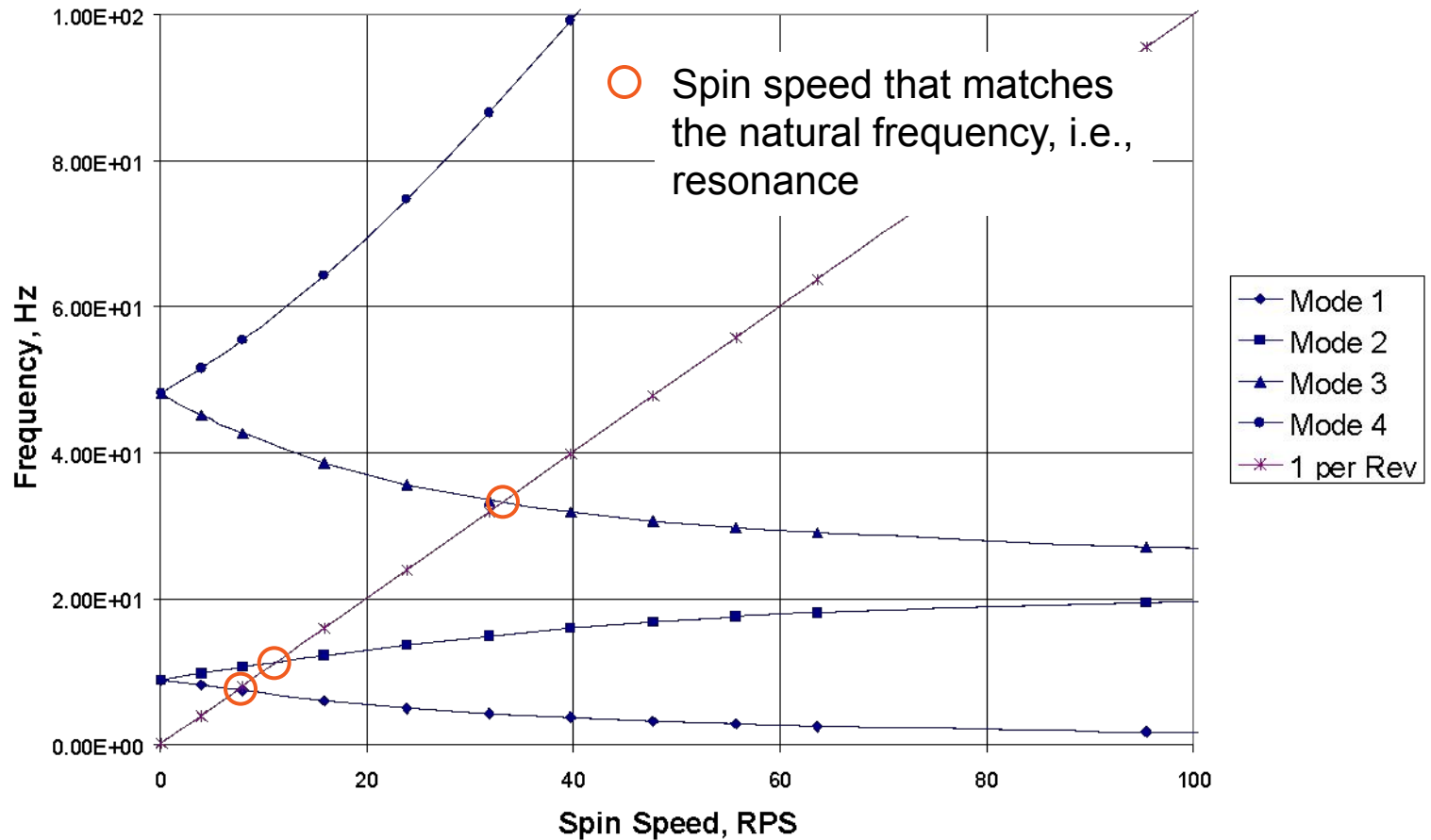

# Critical Speeds

S 8-37



# Input File

```
ID ROTATING DISK
SOL 107
CEND
TITLE = GYROSCOPIC INFLUENCE OF A RIGID DISK ROTATING ON A SHAFT,
SUBTI = NEARLY MASSLESS SHAFT, CRITICAL SPEED ANALYSIS
SPC          = 1
  RGYRO      = 1
  CMETHOD  = 1
  DISP(PHASE) = ALL
BEGIN BULK
.
$ DISK MASS AND GYRO SPECIFICATIONS
CONM2 100  10      157.0-4
      2.45      2.45      4.9
$ GYROSCOPIC COUPLING AND SPEED CONTROL
$rotorg  rotorid  gid1  gid2  etc
ROTORG   1      1      thru 10  by  1
$rgyro   rid     syncflg  refrotr  spdunit  spdlow  spdhigh  speed
RGYRO 1  SYNC  1      RPM      954.93
$rspin   rotorid  gr1da  gridb  gr  spdunit  speed1  speed2  etc.
RSPINR  1      9      10      RPM  954.93
$ COMPLEX EIGENVALUE EXTRACTION
EIGC 1  HESS  MAX      8
ENDDATA
```

Note:  $I_p$  is required on the CONM2

Changed from ASYNC  
to change spin speed  
with eigen frequency



# Results

## COMPLEX EIGENVALUE SUMMARY

ROOT NO.	EXTRACTION ORDER	EIGENVALUE (REAL)	EIGENVALUE (IMAG)	FREQUENCY (CYCLES)	DAMPING COEFFICIENT
1	4	-5.323785E-14	4.676258E+01	7.442496E+00	2.276942E-15
2	3	4.162563E-16	7.063671E+01	1.124218E+01	-1.178583E-17
3	2	-1.070884E-15	2.084957E+02	3.318313E+01	1.027248E-17
4	1	2.390711E+02	1.472887E-15	0.0	0.0



# Critical Speeds on the Campbell Diagram

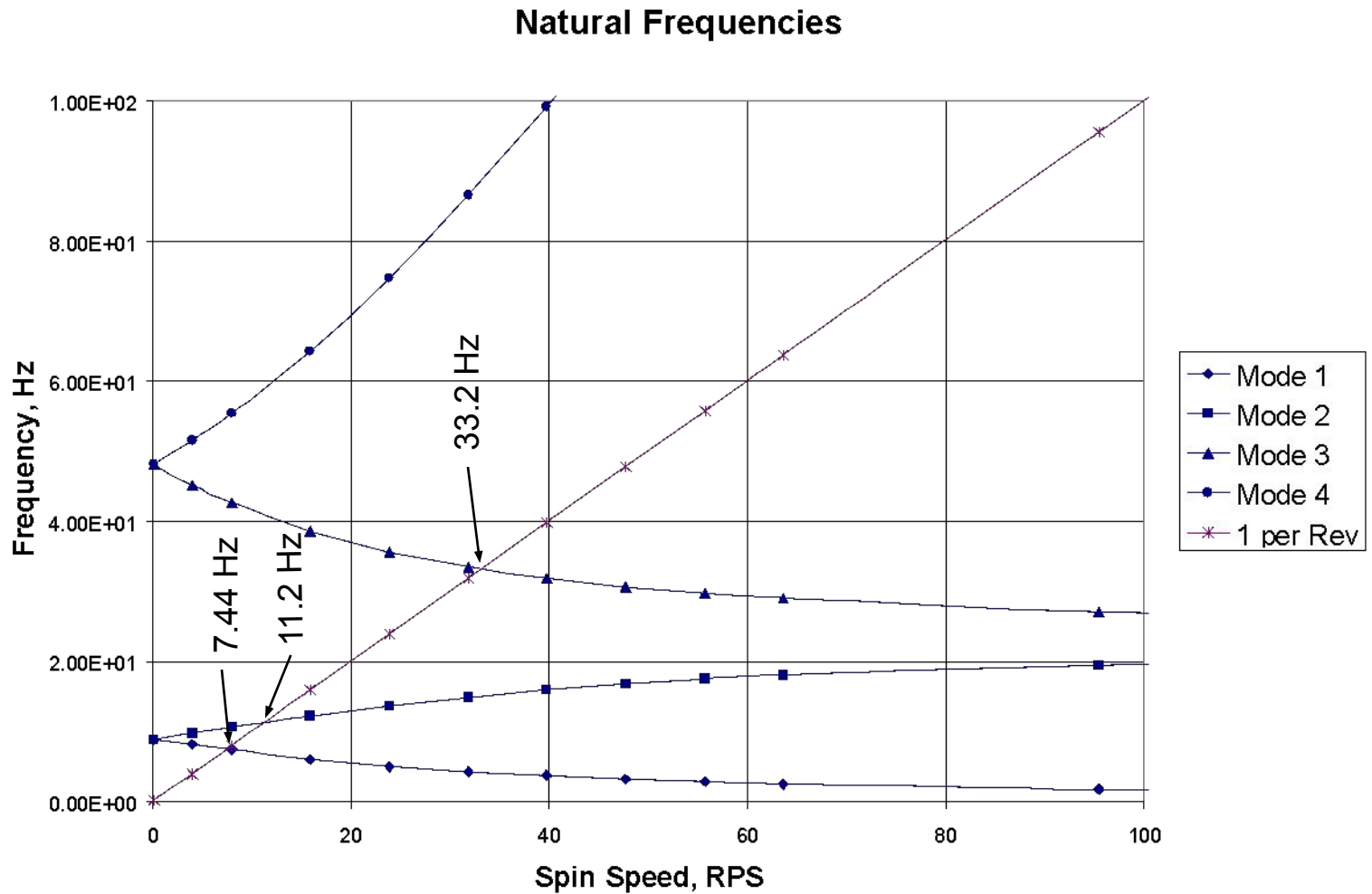



# Frequency Response Analysis



# Input File

```
ID ROTATING DISK
SOL 108
CEND
TITLE = GYROSCOPIC INFLUENCE OF A RIGID DISK ROTATING ON A SHAFT
SUBTI = MASSLESS SHAFT CBAR MODEL
LABEL = FORCED RESPONSE                                RGYRO
SPC          = 1
RGYRO        = 1
FREQ         = 1
DLOAD        = 10
DISP(PHASE) = ALL
BEGIN BULK
$ PARAMETERS
$PARAM      ASING 1
PARAM COUPMASS1
PARAM GRDPNT      10
PARAM POST      0
ASET 10      1245
.
ASET 10      1245
$ GEOMETRY
GRID 1          0.0  0.0  0.0          6
= *1 = = = *10.0 ==
=8
$ SHAFT CONNECTIVITY SPECIFICATION
$CBAR          1    1    1    2    100
CBAR 1          1    1    2    10.0  0.0  0.0
= *1 = *1 *1 ==
=7
$GRID          100          10.0  0.0  100.0          123456
$ SHAFT PROPERTIES
PBAR 1          1    10.0  1.647706 1.647706
MAT1 1          1.0+6      0.3  1.0-9
$ BOUNDARY CONDITIONS
SPC1 1          123  1
SPC1 1          12  7
```



# Input File

```
$ DISK MASS AND GYRO SPECIFICATIONS
CONM2 100 10 157.0-4
      2.45      2.45      4.9
$ GYROSCOPIC COUPLING AND SPEED CONTROL
$rotorg  rotorid  gid1 gid2 etc
ROTORG  1 1 thru 10 by 1
$rgyro  rid  syncflg  refrotr  spdunit  spdlow  spdhigh  speed
RGYRO 1 SYNC 1 RPM 954.93
$rspinr  rotorid  grida gridb gr  spdunit  speed1  speed2  etc.
RSPINR  1 9 10 RPM 954.93
$ DYNAMIC LOAD SPECIFICATION
DLOAD 10 1. 1. 1 1. 2
FREQ1 1 0.1 1.0 400
DAREA 16 10 1 1.0
DAREA 17 10 2 1.0
DPHASE 17 10 2 -90.
RLOAD1 1 16 18
RLOAD1 2 17 17 18
TABLED1 18
      0. 1. 5000. 1. ENDT
ENDDATA
```



# Forward Whirl

- The forward whirl mode is excited

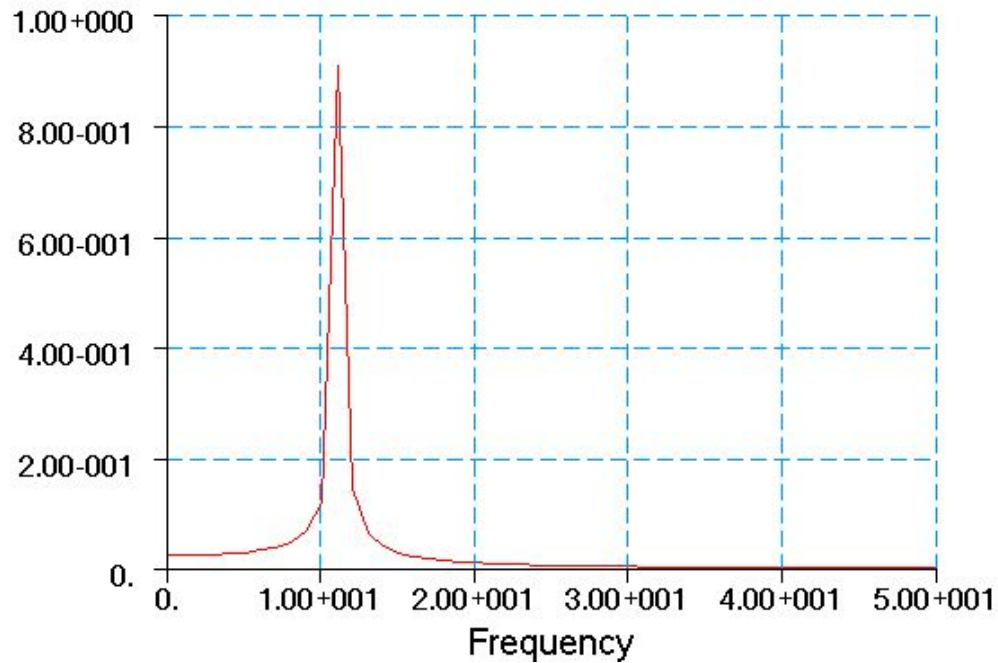

# Nonlinear Transient Response

S 8-45



# Out of Balance Excitation

- Dimentberg rotor to illustrate UNBALNC input

UNBALNC	RID	MASS	GRID	X1	X2	X3			
	ROFFSET	THETA	ZOFFSET	Ton	Toff	CFLAG			

# Input File

```
ID QUAD4 MODEL
TIME 1000
DIAG 8 $,15,56
SOL 129
CEND
TITLE = QUAD4 MODEL SHAFT and STIFF HEXA DISK
SUBTI = Overhung Disk SOL 129
LABEL = Two support points at sta 0 and sta 60
  echo=none
  PARAM,GRDPNT,10000
  RGYRO   = 1   $ Rotor selection
  TSTEPNL = 1   $ Time step control
  DISP(PLOT) = ALL
  OLOAD(PLOT) = ALL
  set 1 = 10000
  NLLOAD = 1
$  ESE(PLOT,PEAK)   = ALL
  STRESS(PLOT)      = ALL
  SPCFOR(PLOT)      = ALL
```

## OUTPUT (XYPLOT)

```
XAXIS=YES
YAXIS=YES
XTITLE=   Time, sec.
TCURVE= RTR LAT DISP, grid 7000-T2
XYPLOT,xyprint DISP / 7000(T2)
TCURVE= RTR VERT DISP, grid 7000-T3
XYPLOT,xyprint DISP / 7000(T3)
TCURVE= RTR LAT DISP, grid 10000-T2
XYPLOT,xyprint DISP / 10000(T2)
TCURVE= RTR VERT DISP, grid 10000-T3
XYPLOT,xyprint DISP / 10000(T3)
```

# Input File

```
BEGIN BULK
PARAM LGDISP      1
PARAM POST      0
PARAM PRGPST     NO
$
$ rotor input
$
$rotorg   rotorid   gid1  gid2  etc
ROTORG   1      1000  THRU 10000 by   1000
$rspint   rotorid   grida gridb gr   spdunit   teid
RSPINT   1      9000 10000      FREQ 100
TABLED1   100
          0.    0.    .01  0.    2.0  15.9155  1000.15.9155
          ENDT
$
$ DYNAMIC LOAD SPECIFICATION AND SOLUTION TIME STEP
$
TSTEPNL   1      20000 0.001 10
UNBALNC   1      1.56-4  10000 0.    1.    0.
          1.0  0.0  0.0  0.0  1000. none
```







# Damping



# New Damping Inputs

- Different forms of damping are now
  - Accessible through Case Control command/bulk data entry
  - Consolidating the use of parameters, G, ALPHA1, ALPHA2, W3, W4, WH and GE material scaling
- Case Control
  - SEDAMP
  - RSDAMP
- Bulk Data
  - DAMPING
  - HYBDAMP

# New Damping Inputs

- SEDAMP and RSDAMP Case Control Commands
- SEDAMP - Requests parameter and hybrid damping for superelements
  - SEDMAP = n
  - Where n is the identification number of the DAMPING bulk data entry
- RSDAMP - Requests parameter and hybrid damping for the residual structure
  - RSDAMP = n
  - Where n is the identification number of the DAMPING bulk data entry



# Bulk Data DAMPING Entry

- Bulk Data Entry – DAMPING
- Format

DAMPING	ID	G	ALPHA1	ALPHA2	HYBRID	GEFACT			
	W3	W4	WH						

- Example

DAMPIN G	1				1				
-------------	---	--	--	--	---	--	--	--	--

S 8-53

# Field Contents

- ID** Damping entry identification number. (Integer  $> 0$ , no Default)
- G** Structural damping coefficient, see Remark 1. (Real, Default = 0.0)
- ALPHA1** Scale factor for mass portion of Rayleigh damping, see Remark 4. (Real, Default = 0.0)
- ALPHA2** Scale factor for stiffness portion of Rayleigh damping, see Remark 4. (Real, Default = 0.0)
- HYBRID** Identification number of HYBDAMP entry for hybrid damping, (Integer  $> 0$ , Default = 0)
- GEFACT** Scale factor for material damping. (Real, Default = 1.0)
- W3** Average frequency for calculation of structural damping in transient response, (Real  $> 0.0$ , Default = 0.0)
- W4** Average frequency for calculation of material damping in transient response (Real  $> 0.0$ , Default = 0.0)
- WH** Average frequency for calculation of hybrid 'structural' damping in transient response, (Real  $> 0.0$ , Default = 0.0)

# Damping

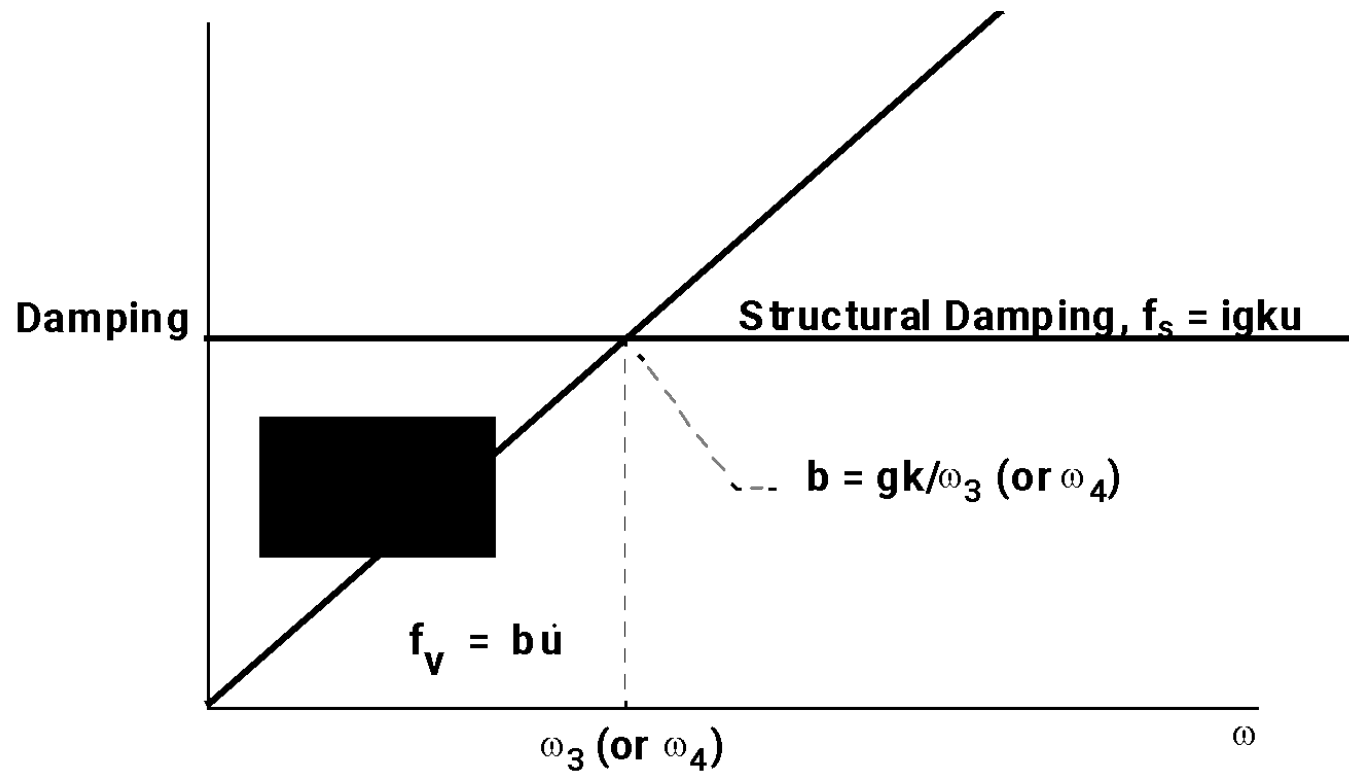

# Bulk Data HYBDAMP Entry

- Hybrid modal damping for direct dynamic solutions
- Specifies the eigenvalue extraction method and damping for hybrid damping calculations.

- Format

1                    2                    3                    4                    5                    6                    7                    8                    9                    10

HYBDAMP	ID	METHOD	SDAMP	KDAMP					
---------	----	--------	-------	-------	--	--	--	--	--

- Example

1                    2                    3                    4                    5                    6                    7                    8                    9                    10

HYBDAMP	1	100	200						
---------	---	-----	-----	--	--	--	--	--	--



# Field Contents

- ID** Identification number of HYBDMP entry (Integer 0; Required) >
- METHOD** Identification number of METHOD entry for modes calculation. (Integer [ 0, Required)
- SDAMP** Identification number of TABDMP1 entry for modal damping specification.(Integer > 0; Required)
- KDAMP** Selects modal “structural” damping. See Remark 1. (Character: “Yes” or “NO”,Default = “NO”)

## Remarks:

1. For KDAMP = “YES”, the viscous modal damping is entered into the complex stiffness matrix as structural damping.
2. Hybrid damping is generated using modal damping specified by the user on TABDMP entries.

# Squeeze Film Damper for Nonlinear Force

1	2	3	4	5	6	7	8	9	10
NLRSFD	SID	GA	GB	PLANE	BDIA	BLEN	BDLR	SOLN	
	VISCO	PVAPCO	NPORT	PRES1	THETA1	PRES2	THETA2	NPNT	
	OFFSET1	OFFSET2							

- The squeeze film damper (SFD) was implemented as a nonlinear force similar to the NLRGAP. The SFD forces are activated from the Case Control Section using the NONLINEAR command. The NLRSFD bulk data entry has the above input format.
- See MD-Nastran 2006r1 QRG or Release Guide for details of each field. See Section 7.1 of the MSC.Nastran 2005 Release Guide for more complete description and example problem.

# Field Contents

**SID** – идентификационный номер LOAD SET

**GA** – внутренний узел опоры

**GB** – внешний узел опоры

**PLANE** – плоскость ориентации

**BDIA** – внутренний диаметр

**BLEN** – длина опоры

**BDLR** – радиальный зазор

**SOLN** – опции решения

**VISCO** – вязкость жидкости

**PVAPCO** – давление жидкости

**NPORT** – количество входов

**THETA1** – угловая позиция входа 1

**PRES2** – граничное давление для входа 2

**THETA2** – угловая позиция входа 2

**NPNT** – число точек по окружности демпфера

**OFFSET1** – отступ центрального узла в горизонтальном направлении

**OFFSET2** – отступ центрального узла в вертикальном направлении

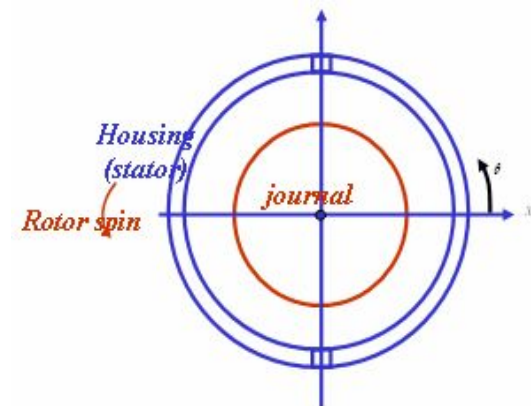
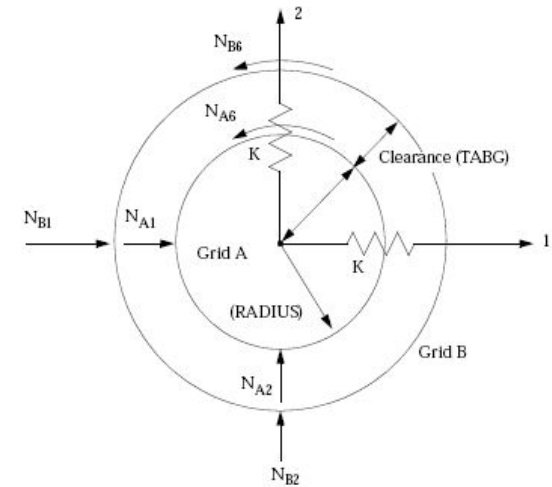

# Squeeze Film Damper for Nonlinear Force

1	2	3	4	5	6	7	8	9	10
CBUSH2D	EID	PID	GA	GB	CID	PLANE	SPTID		

- For better accuracy and to facilitate use in other solution sequences the NLRSD was also implemented as an element. The Squeeze Film Damper was added as an option of a more general 2-D bearing element (CBUSH2D).

- EID** Element identification number (Integer > 0)
- PID** Property identification number of a PBUSH2D entry. (Integer > 0).
- GA** Inner grid (Integer > 0).
- GB** Outer grid (Integer > 0).
- PLANE** Orientation plane CID, XY,YZ, ZX (Character)
- SPTID** Optional rotor speed input for use with table lookup or DEQATN generation of element properties (Integer > 0 or blank).

# Squeeze Film Damper for Nonlinear Force

1                      2                      3                      4                      5                      6                      7                      8                      9                      10

PBUSH2D	PID	K11	K22	B11	B22	M11	M22		
	"SQUEEZE"	BDIA	BLEN	BCLR	SOLN	VISCO	PVAPCO		
	NPORT	PRES1	THETA1	PRES2	THETA2	OFFSET1	OFFSET2		

- Defines linear and nonlinear properties of a two-dimensional element (CBUSH2D entry).
- Stiffness, damping and Mass for linear element similar to the CBUSH element except the CBUSH2D only specifies values in two directions only.
- The nonlinear element input follows the NLRSGD input.
- See MD.Nastran 2006r1 QRG and Release Guide for specific details of the input fields for the PBUSH2D entry.

# Field Contents

- PID** Property identification number (Integer > 0, Required).
- K11** Nominal stiffness in T1 rectangular direction (Real, Required).
- K22** Nominal stiffness in T2 rectangular direction (Real, Required).
- B11** Nominal damping in T1 rectangular direction (Real, Default = 0.0).
- B22** Nominal damping in T2 rectangular direction (Real, Default = 0.0).
- M11** Nominal acceleration-dependent force in T1 direction (Real, Default =0.0).
- M22** Nominal acceleration-dependent force in T2 direction (Real, Default =0.0).
- 'SQUEEZE'** Indicates that squeeze-film damper will be specified (Character, Required).
- BDIA I** Inner journal diameter. (Real > 0.0, Required)
- BLEN** Damper length. (Real > 0.0, Required).
- BCLR** Damper radial clearance (Real > 0.0, Required).
- SOLN** Solution option: LONG or SHORT bearing (Character, Default =LONG).
- VISCO** Lubricant viscosity (Real > 0.0, Required).
- PVAPCO** Lubricant vapor pressure (Real, Required).
- NPORT** Number of lubrication ports: 1 or 2 (Integer, no Default).
- PRES1** Boundary pressure for port 1 (Real > 0.0, Required if NPORT= 1 or 2).
- THETA1** Angular position for port 1 ( 0.0< Real < 360.0, Required if NPORT= 1 or 2).
- PRES2** Boundary pressure for port 2 (Real > 0.0, Required if NPORT= 2).
- THETA2** Angular position for port 2 ( 0.0< Real < 360.0, Required if NPORT= 2).
- OFFSET1** Offset in the SFD direction 1, see Remark 3. (Real, Default = 0.0).
- OFFSET2** Offset in the SFD direction 2, see Remark 3. (Real, Default = 0.0)



# Rotors and Aeroelasticity

S 8-63



# Gyroscopic Terms Added to Aeroelasticity

- SOLs 145 and 146 have the same rotordynamic equations as complex eigenvalue and frequency response analyses.



# FSW Full Model Transient Response

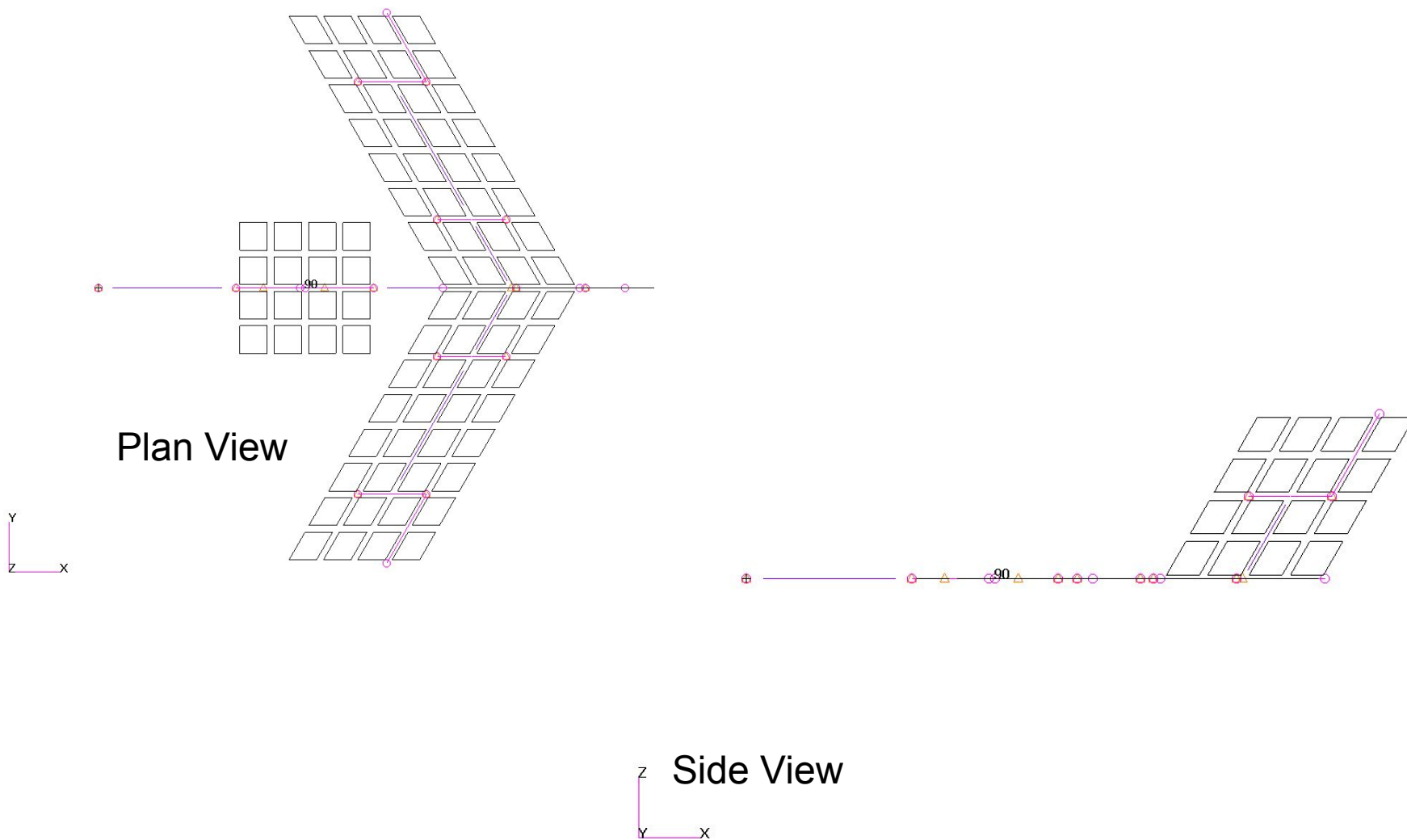

S 8-65

# Canard Control Surface Input Deflection

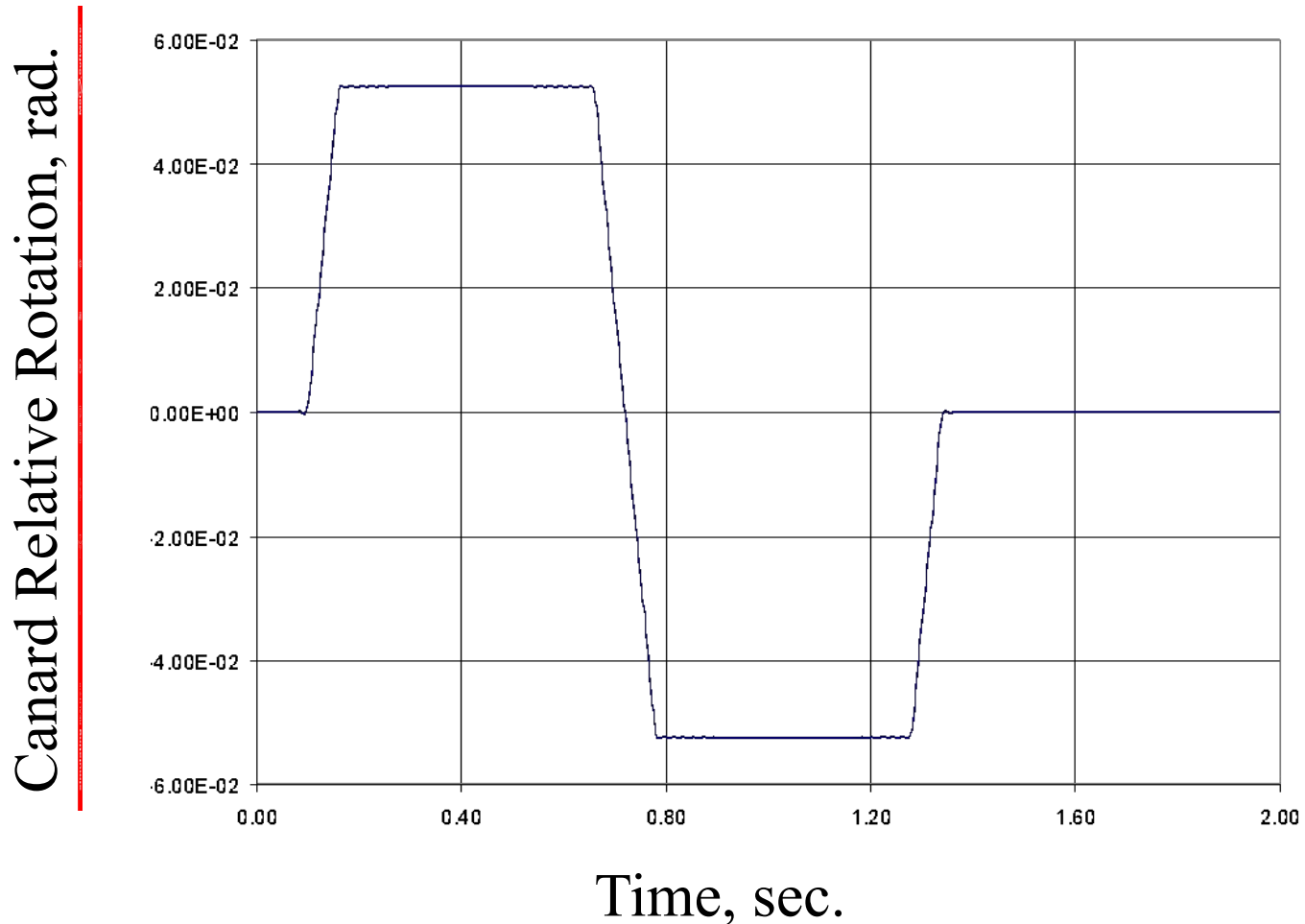

S 8-66

# Pitch, Roll & Yaw Response

Grid 90

Rotation Displacement, rad.

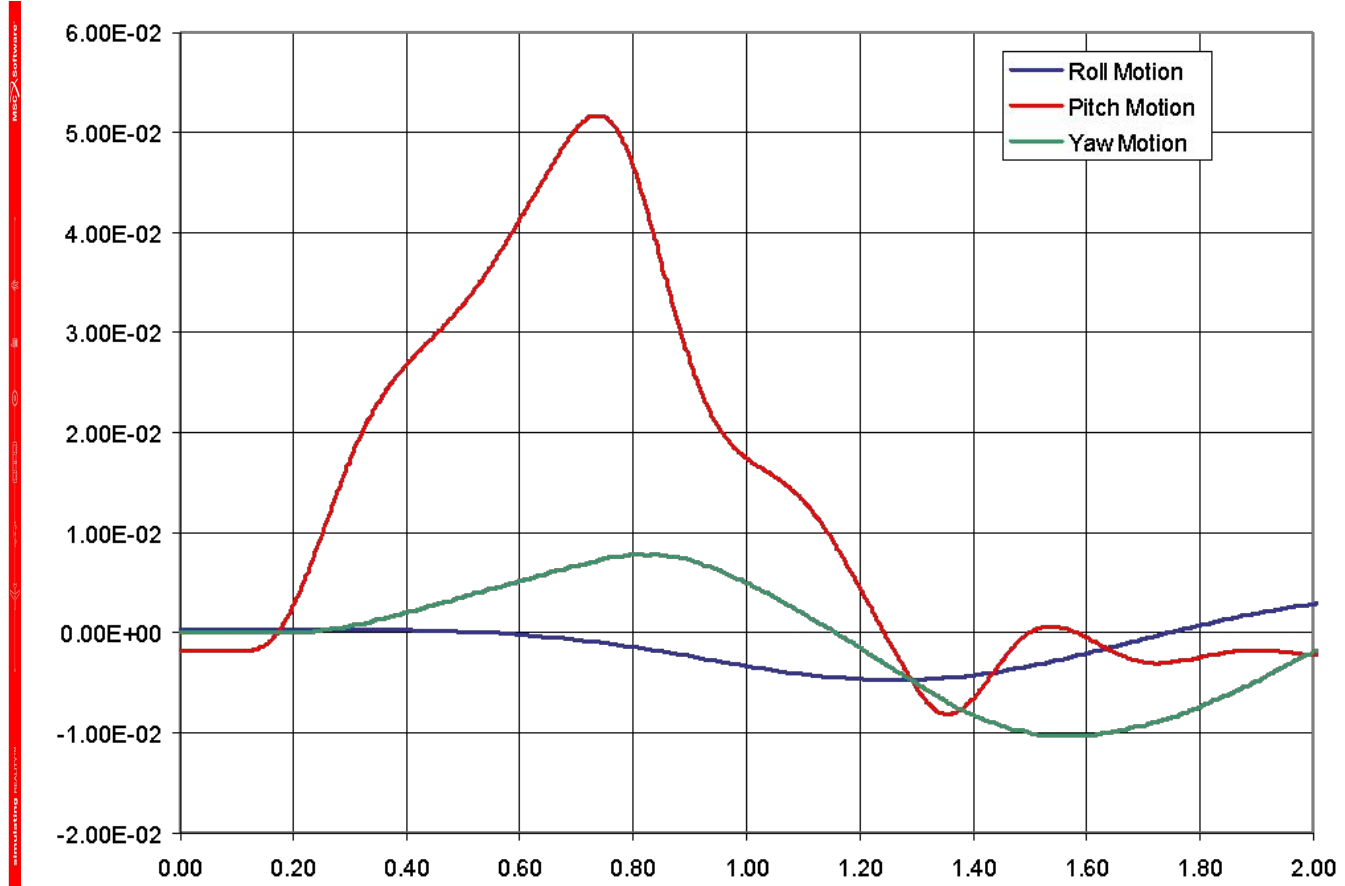

Time, sec.

S 8-67

# Campbell Diagrams

S 8-68



# Campbell Diagrams

- Let's first look at a 2 rotor model

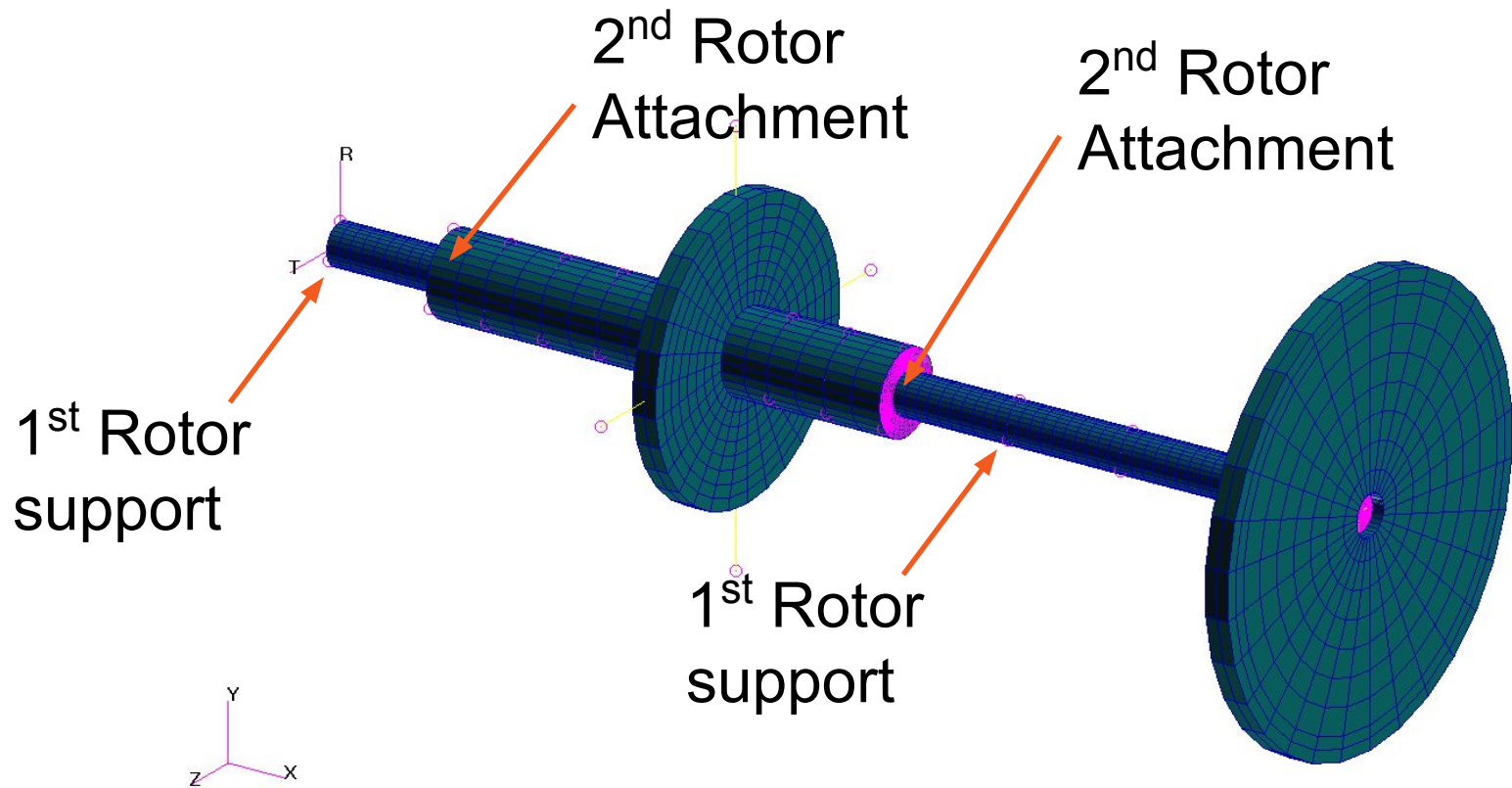

# Diagram for the 2 Rotor Model

## Natural Frequencies

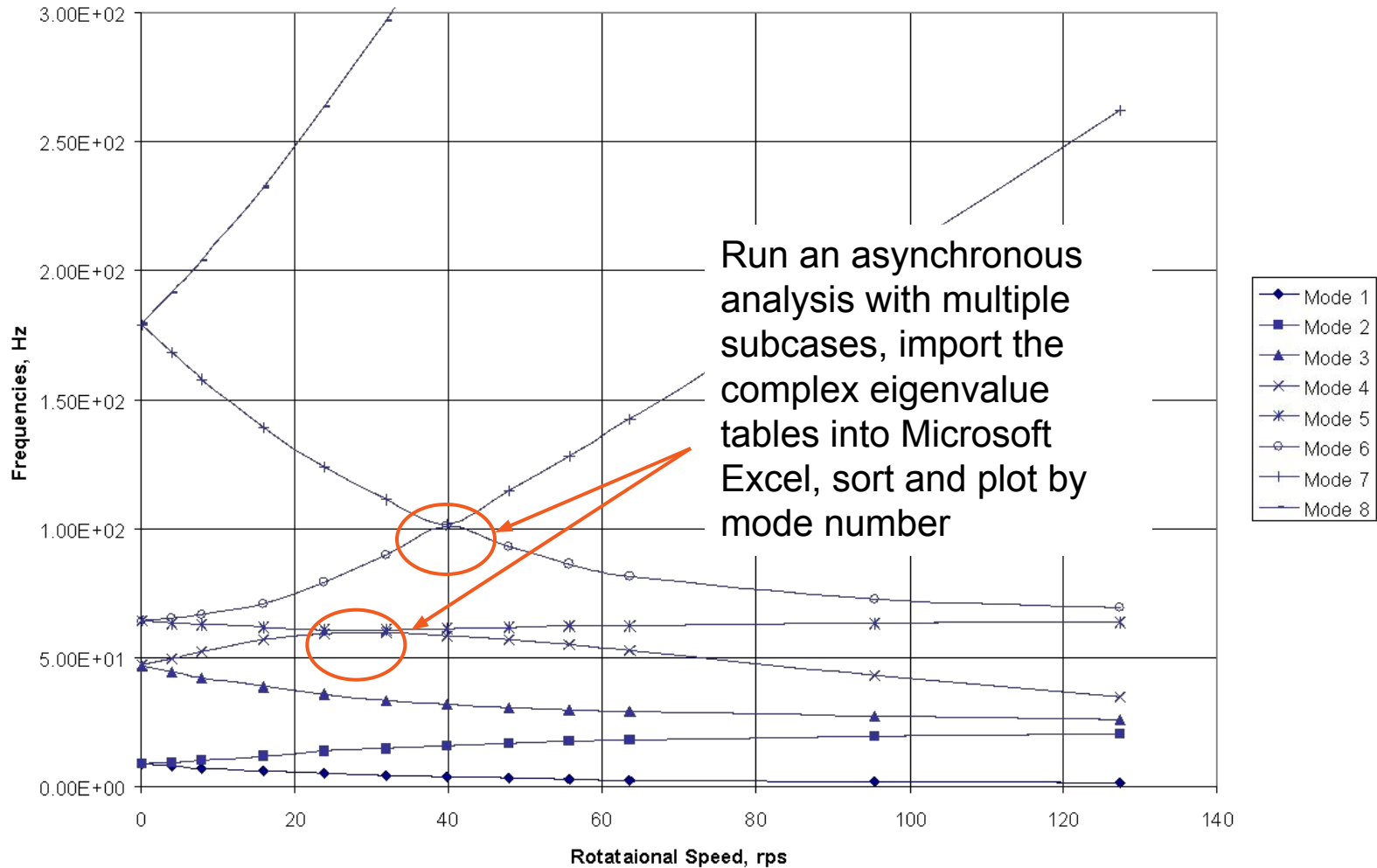

S 8-70

# New Inputs

- Used in Complex Eigenvalue Analysis with SOL 107 or 110
- Case Control Command
  - CAMPBELL=n
  - Selects CAMPBLL bulk data entry

# Bulk Data

1                    2                    3                    4                    5                    6                    7                    8                    9                    10

CAMPBLL	CID	VPARM	DDVALID	TYPE	ID	NAME/FID			
---------	-----	-------	---------	------	----	----------	--	--	--

- Parameters for Campbell diagram generation.

**CID** Identification number of entry (Integer >0).

**VPARM** Variable parameter, 'SPEED', 'PROP', 'MAT'  
Only SPEED is implemented, PROP and MAT are not.

**DDVALID** Identification number of DDVAL entry.

**TYPE** For VPARAM set to 'SPEED' allowable entries are: 'FREQ'  
and 'RPM', others not implemented.

**ID** Property or material entry identification number (Integer >  
0), not required for 'SPEED'

**NAME/ID** No data needed for 'SPEED'



# Campbell Diagram

- Data Generation Requires forward and backward rotor mode identification and tracking
- Forward and backward rotor modes are identified using proportional kinetic and strain energies of the reference rotor compared to the total structure.
- The rotor modes must be tracked in case the eigenvalues of the modes change ordering.
- Tracking the modes may require running from highest to lowest spin speeds.