



Budapesti Műszaki és Gazdaságtudományi Egyetem
Szerves Kémia és Technológia Tanszék

Industrial Safety

2019

1. Introduction (09.11)
2. Basic concepts (09.18)
3. Fire and explosion (09.25)
4. Explosion prevention, sources of ignition (10.02)
5. Overpressure vessels (10.09)
6. Test 1 (10.16)
7. National Day (10.23) – non-working day
8. Toxic materials (10.30)
9. Flame retardancy (11.06)
10. Biosafety I. (11.13)
11. Biosafety II. (11.20)
12. Test 2 (11.27)
13. Repeat test (12.04)



Industrial Safety

Webpage: <http://oct.bme.hu/safety>

name: safety

Password: sft2012



Chemical plant



Why You Should Take Notes?

Researchers studied the learning characteristics.
Chemie Technik, **28, 78 (1999)**

The proportion of the remaining information (%)

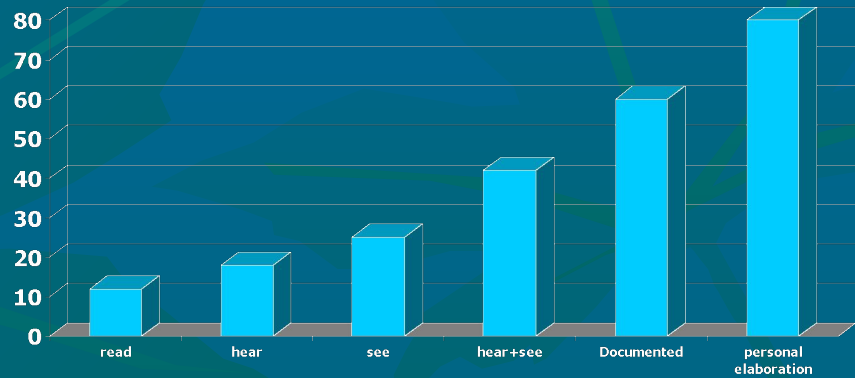

Distribution of marks in safety
Chemical Faculty

No. students

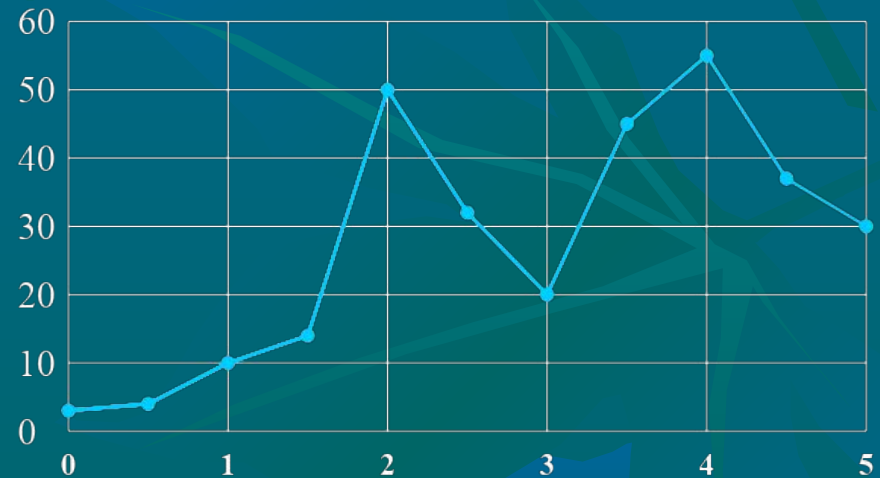

There is no university textbook



Basic concepts

SAFETY ENGINEERING

safety (safe work at workspace)

security (asset protection, protection against sabotage)

1. PREVENTION OF ACCIDENT

ACCIDENT: onefold, sudden, unexpected event, independent of the will of the workers,; the employee reached unexpectedly

– does not know what danger awaits him

– knows, but trusts in his experience

Aim: accident prevention, elimination

– technical

– legal

– educational task



Basic concepts

2. HEALTH AT WORK

PREVENTION OF OCCUPATIONAL HARM (DISEASE)

Characteristics: Sustained, regular effect (years, decades)

- Occupational intoxication
- ionizing radiation, noise
- work at high temperature, work at high pressure

AIM: prevent ion occupational disease

- medical task: suitability of workers (determination of the tolerance)
- technical task: ensure the conditions



Basic concepts

OCCUPATIONAL SAFETY AND HEALTH (OSH)

- Organized activity aimed at ensuring the physical integrity of workers, health protection and accident-free working conditions .
- The incident threatens the entire production chain (production equipment, buildings, etc.)
- The working man is the most important

Working man □ □ Means of production

”safety first”

”make safety a habit”

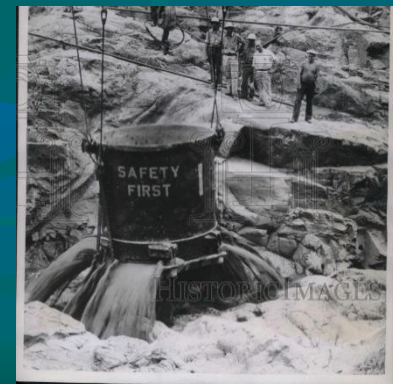

The burning down of a cold storage house in Zalaegerszeg, Hungary (2004)



Incident broad economic impact

Why dangerous the chemical plant?

Chemical plant hazard – distribution of accidents

| | |
|-------------------------|---------------|
| Transportation, traffic | 45 - 50% |
| work with tools | 30 - 40% |
| chemical operation | 7 - 10% |
| FIRE, EXPLOSION | 1 - 2% |

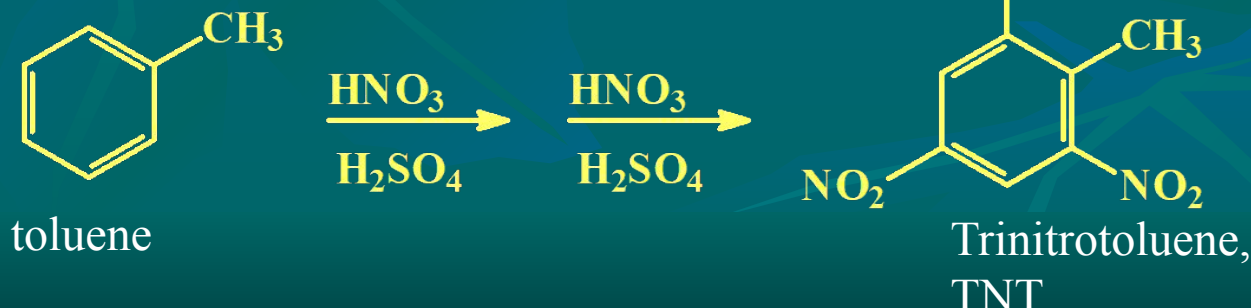

The new material can be:

- smelly
- toxic
- volatile
- flammable
- carcinogenic
- explosive

A HIERARCHY OF PROTECTION

- 1. Organizational measures**
 - prohibitions, regulations
 - education
- 2. Personal protective equipment**

usage depends on the willingness of the worker

 - safety glasses
 - dust masks, gas masks, gloves for different purposes, helmets ...
- 3. Collective protection equipment**

operation does not depend on the willingness of the worker

 - air draw
 - monitoring system

A HIERARCHY OF PROTECTION

4. Safe technology, preventive protection



- unit replacement (film reactor, nitration)

REAGENT SELECTION (halogenation)



explosive intermediar
(half chloride – half ester;
 $\text{S}_{\text{N}}\text{i}$ mech.)

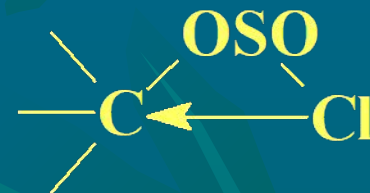

SOCl₂: – only one chlorine reacts

HCl: – corrosive, caustic

– toxic for the respiratory system

– alkaline absorbtion necessary

SO₂: – pollute the environment (to be absorbed)

– Cause acute respiratory diseases

REAGENT SELECTION (halogenation)



- all three chlorine reacts
- H_3PO_3 washed out with water \square neutralization
- some HCl (moisture, hydrolysis)



- CO_2 instead of SO_2
- alkaline absorption, no carbonate formation
- transportation is dangerous and expensive \square
used only where phosgene obtained on site

REAGENT SELECTION

(Alkylation of amines)



R'Br has vesicant effect

HBr salt is formed, washed with water

pollute the environment, (drain)

Br⁽⁻¹⁾ Environmentalists do not really like it

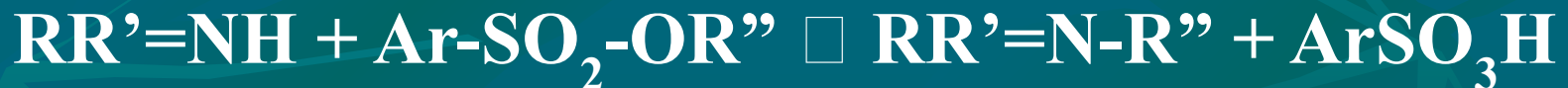

- the sulfonic esters are has not vesicant effect
- the aromatic sulfonic acids can be solved in water
- **Ca⁽²⁺⁾** salt: the acid form can be released with sulfuric acid, and burned (air is polluted, not the water)

UNIT REPLACEMENT (nitration)

Film reactor instead of tank reactor:

- well-cooled, well-stirred
- small amount of material, few kilograms instead of tons
- falling-film reactor, fixed-film reactor, thin film reactor.

NITRATION

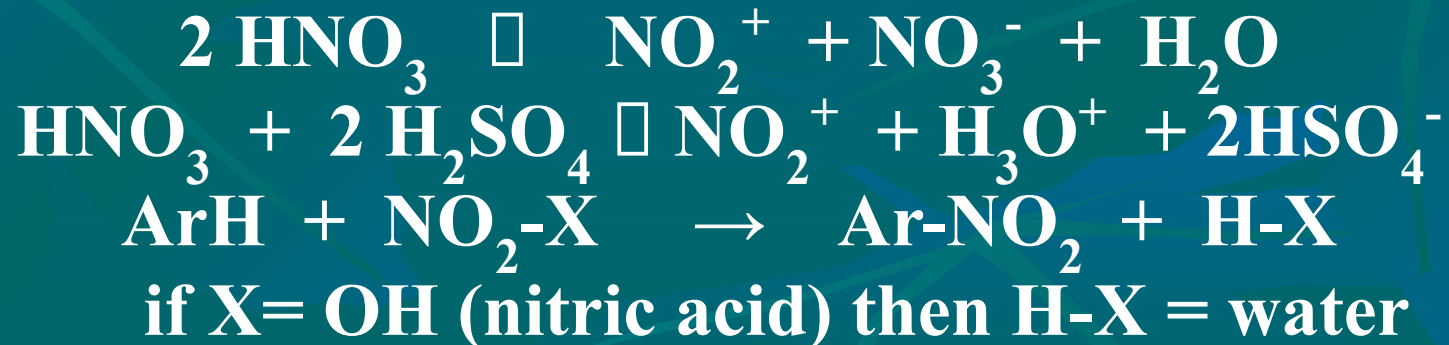



Nitration reactor with internal cooler

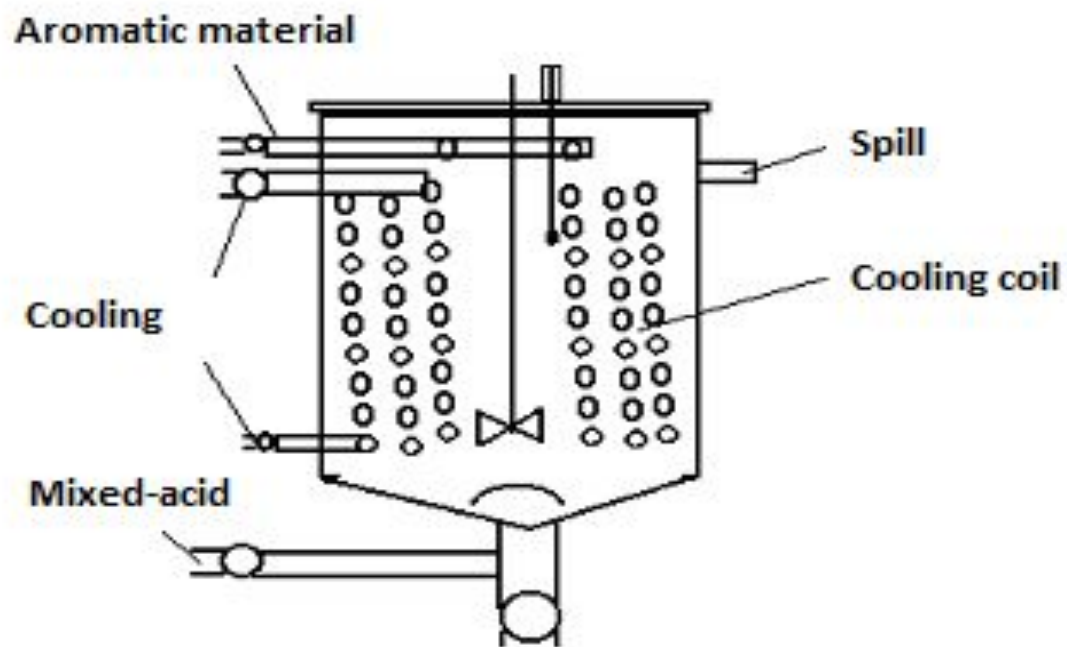



Hough-nitration reactor

Device

- construction material:
corrosion resistant in
acidic medium

- Reaction

- strongly exothermic,
- heterogenous phase



ensures

- heat removal
- stirring

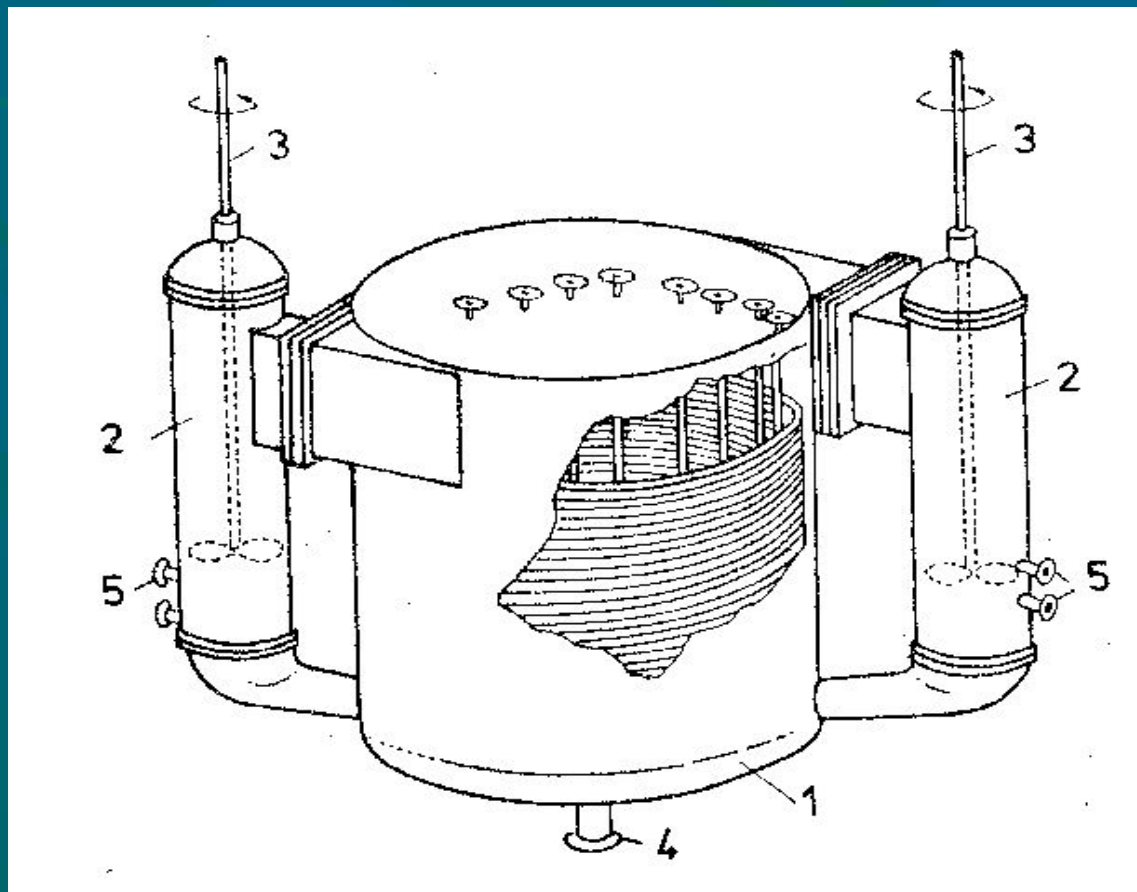



Film reactors

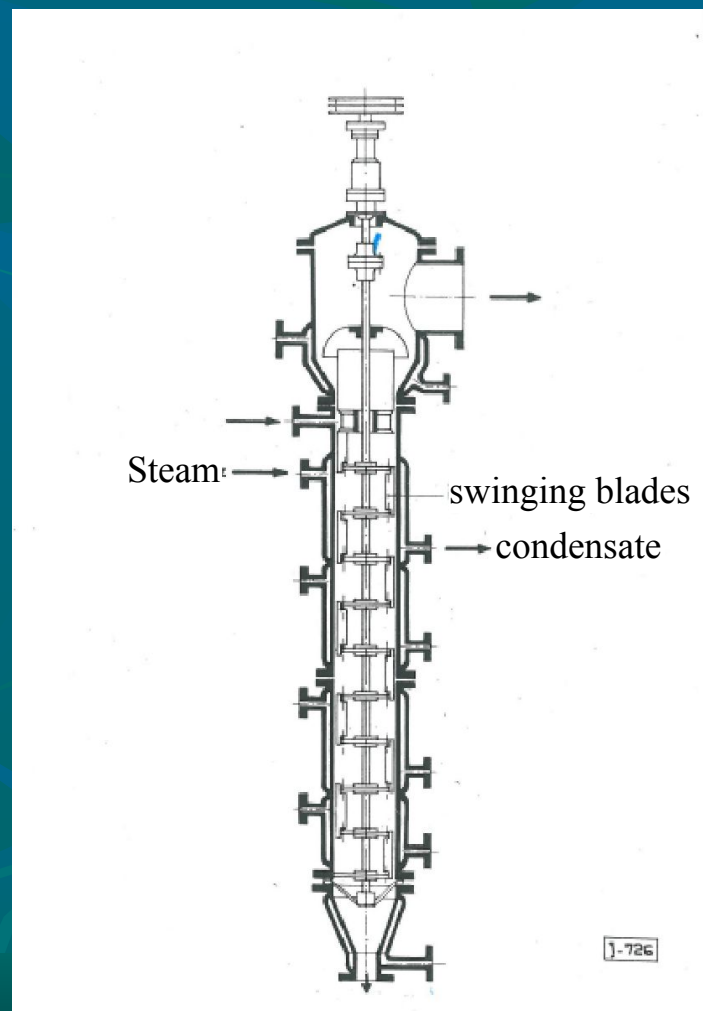
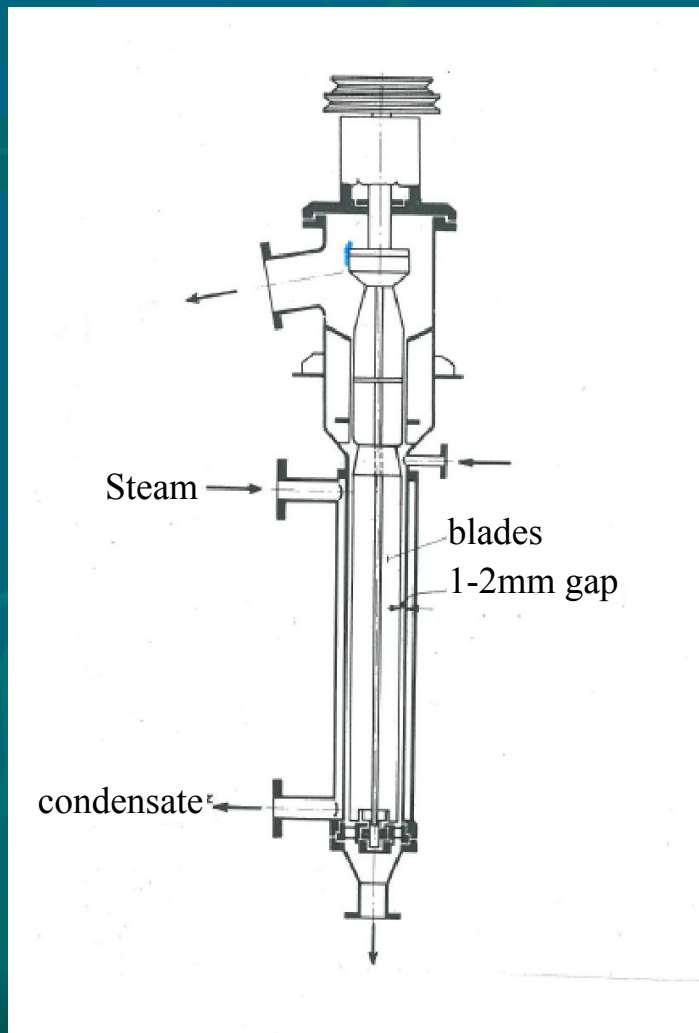

UNIT REPLACEMENT(nitration)

Aim of nitration in the practice: nitration fully complete

- economic issues (the nitric acid is expensive)
- There are no separation issues
- safety and environmental considerations

Practical implementation

- making nitration mixture (mixed-acid)
- nitration (heterogenous reaction; semi-batch or continuous)
- separation (exhausted acid may contain organic substance in the form of emulsion)
- Washing the organic phase (alkali, water); drying
 - Washing liquid contains Na salts of nitro phenols □ cleaned by extraction □ waste
- Exhausted acid
 - Exhausted acid of dinitration □ mononitration
 - Concentration by distillation
 - Diluent of another nitration
 - Strengthening with conc. nitric acid , emulsified organic material □ locally high NO_2^+ konc. □ EXPLOSION
 - fertilizer industry, phosphate digestion
 - Atmosphere of the nitration reactor □ nitrous gases
 - Connected with absorber (10 % NaOH) □ NaNO_2 NaNO_3 waste
 - Burned with natural gas; whole nitrogen content □ N_2

Operating points of exothermic reactions

q = heat released/removed [J/s]

ΔH_R = enthalpy of reaction [J/mol]

r = rate of reaction [mol/s]

$$q = \Delta H_R r$$

