

EN Body Electrical

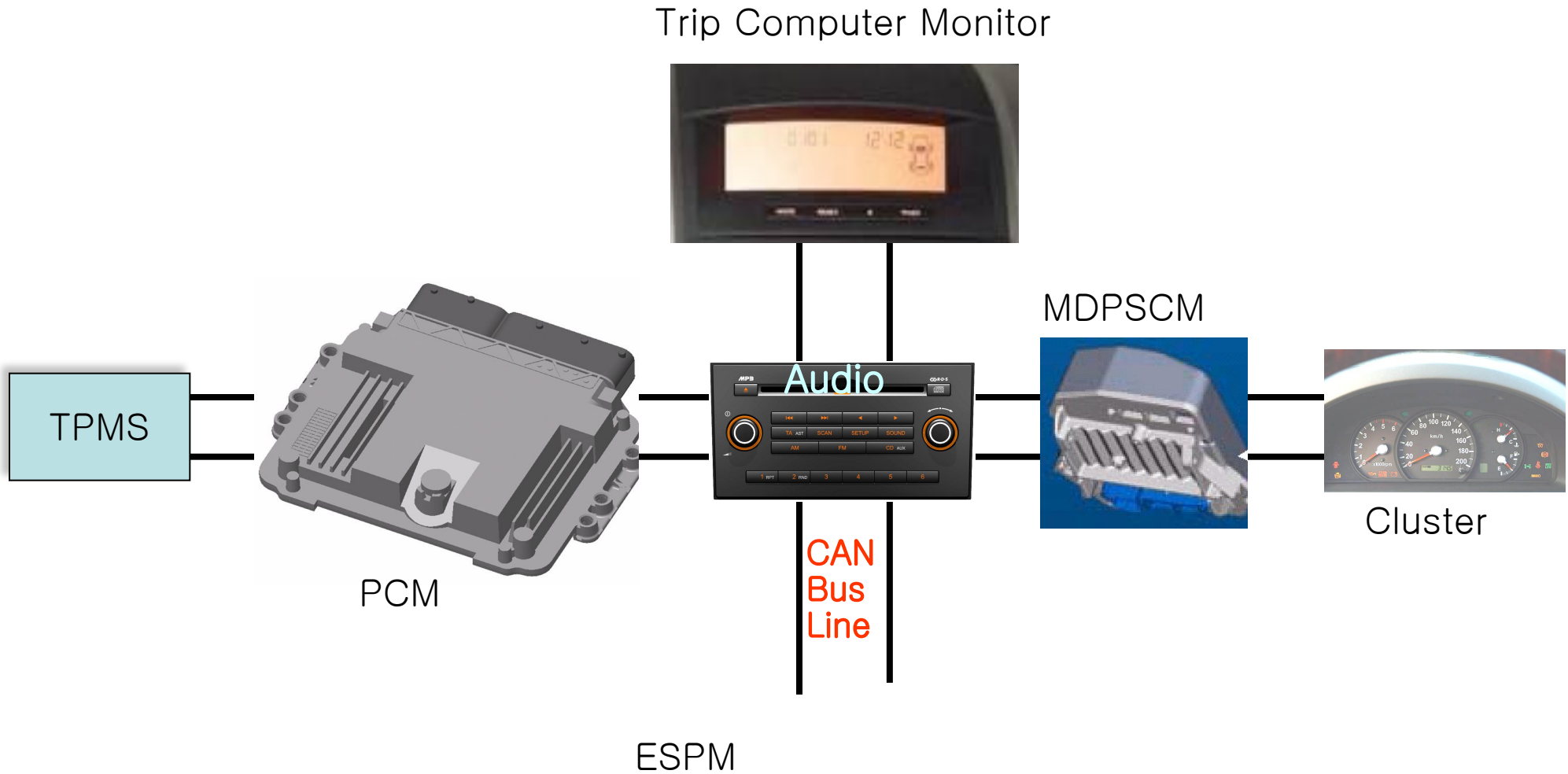



- Driver's door : Door unlock & open by once operation
- Passenger's & Rear door :
 - Cancellation door unlock state at 1th operation (Unlock)
 - Door open at 2nd operation (Open) → for Passenger safety



- Indoor's door lock/unlock Knob deleted

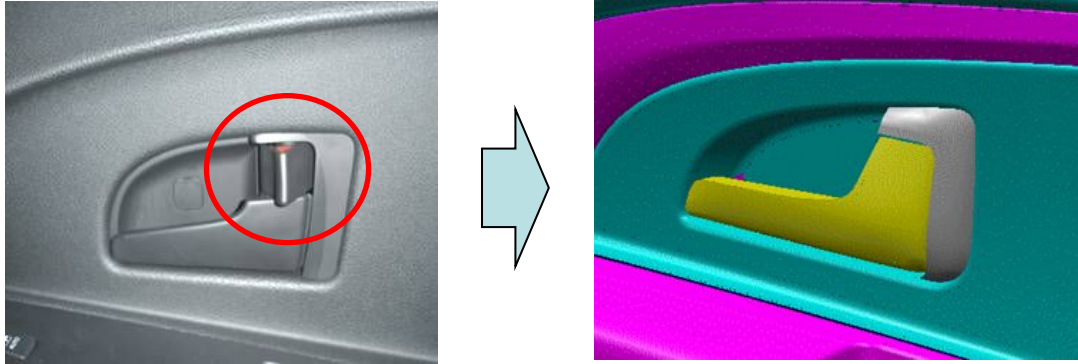

<SAFETY KNOB deleted>

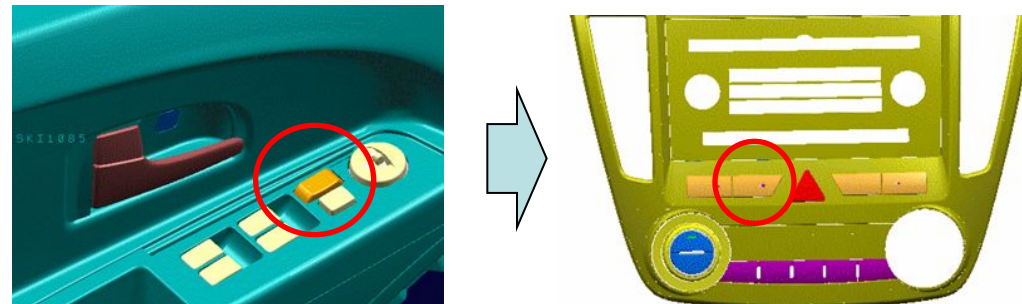

CTR Facial : LOCK / UNLOCK located on center facial panel

Tail gate outside handle : electric type

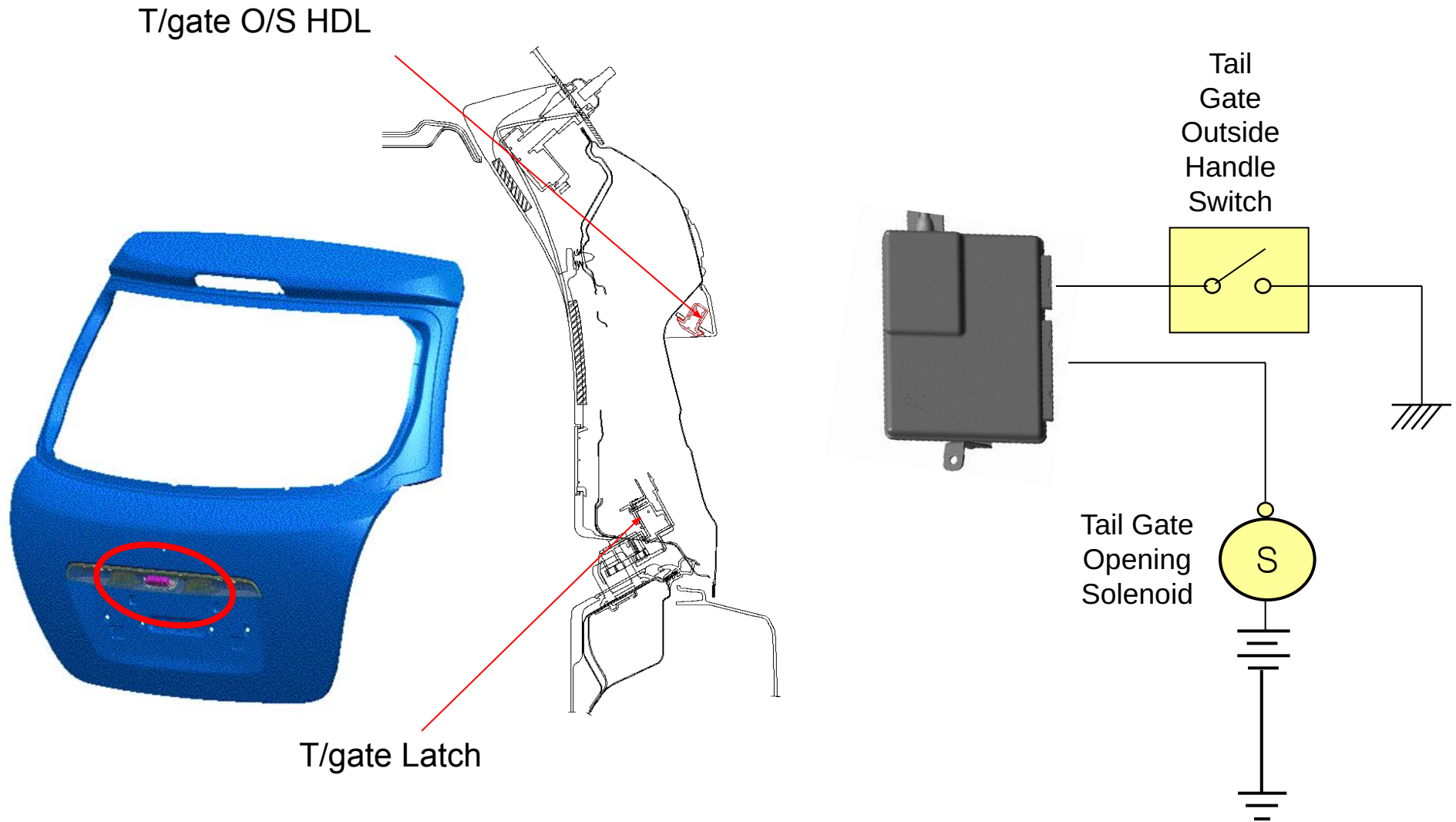

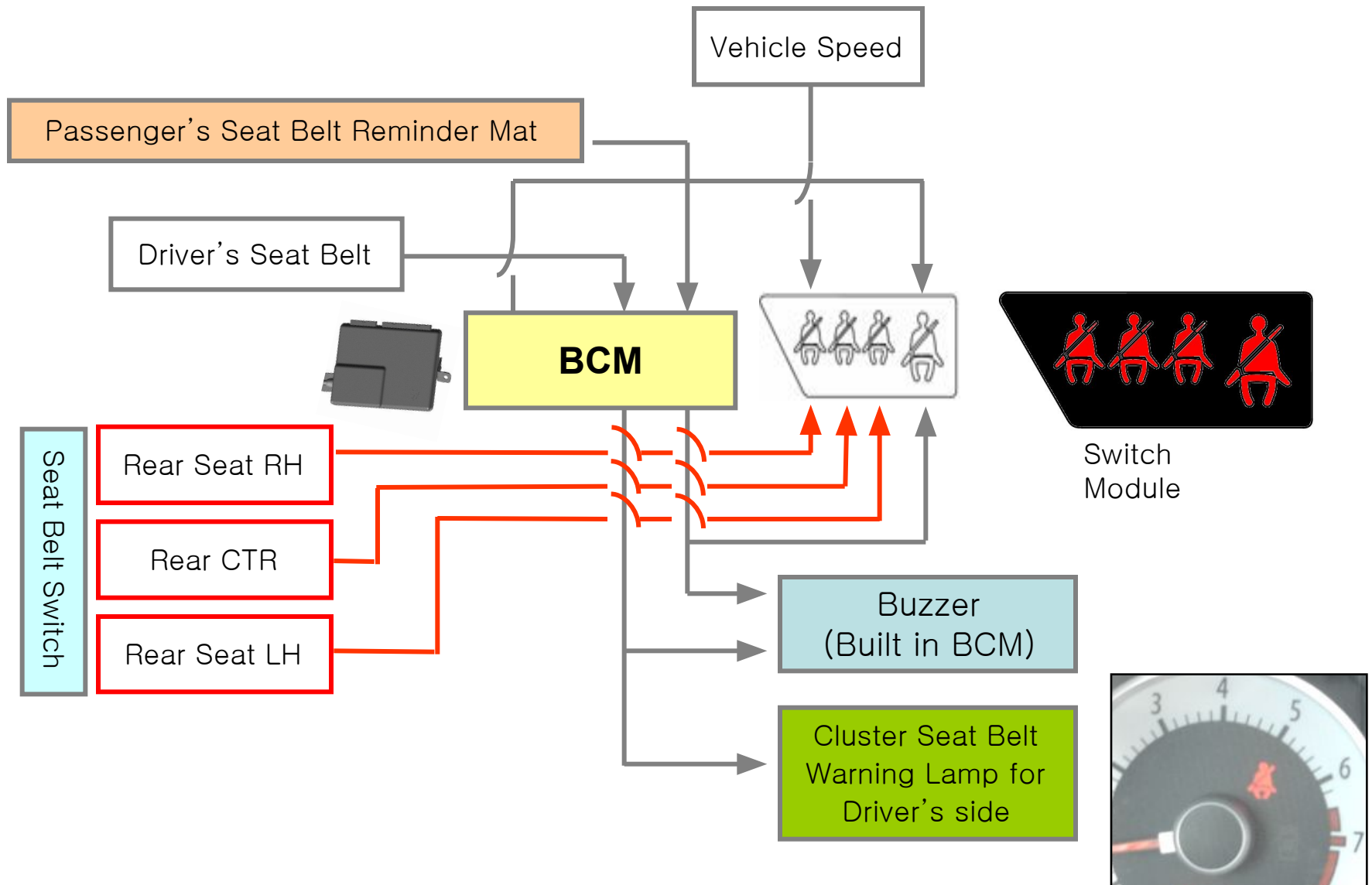

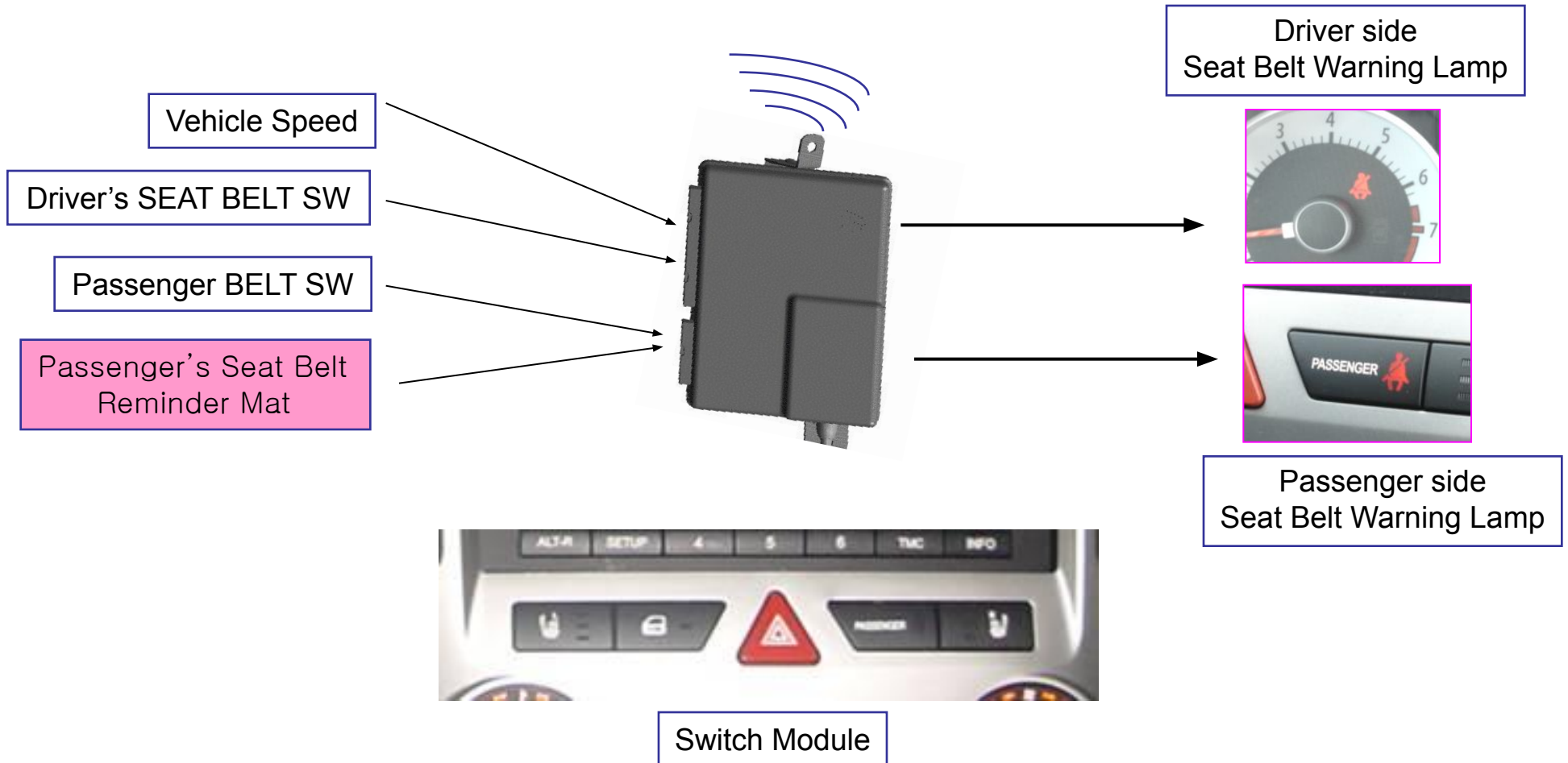

Driver Seat Belt Remind Warning

- Engine ON → Unfasten seat belt → Warning lamp “ON” → Vehicle speed 9 Km/h~20 Km/h
- > Seat Belt Warning lamp flickering → Vehicle speed over 20 Km/h
- > Seat Belt Warning lamp flickering & Buzzer sound -> Fasten seat Belt
- > Warning lamp & Buzzer “Off”

Passenger Seat Belt Remind Warning

- Engine “ON” → Passenger seated -> Unfasten seat belt → Seat Belt Warning lamp flickering
- Vehicle speed over 20 Km/h -> Seat Belt Warning lamp flickering & Buzzer sound
- > Fasten seat Belt -> Warning lamp & Buzzer “Off”

Rear Seat Belt Remind Warning

- Engine “ON” → Unfasten seat belt → Warning lamp “ON” → Vehicle speed 9 Km/h~20 Km/h
- Rear Seat Belt Warning lamp flickering → Vehicle speed over 20 Km/h
- Rear Seat Belt Warning lamp flickering → Fasten seat Belt -> Warning lamp “Off”

The 3 mode actuators (Vent, floor, defrost) allow an occupant to choose the air flow mode to desired position.

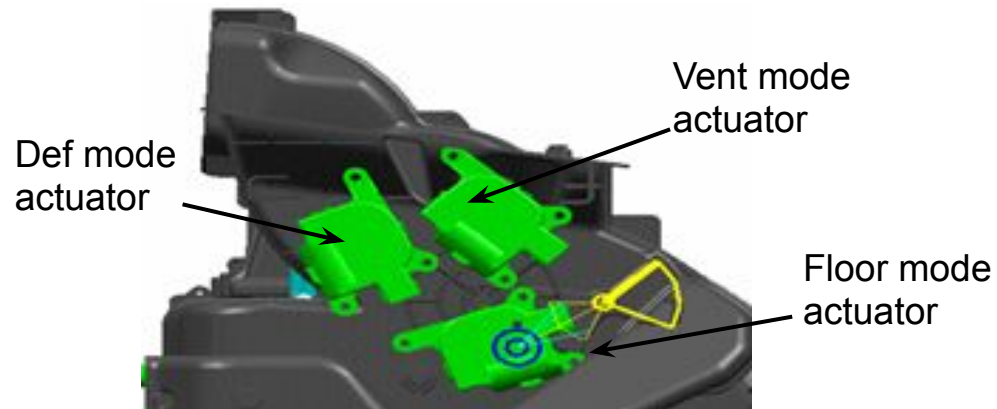
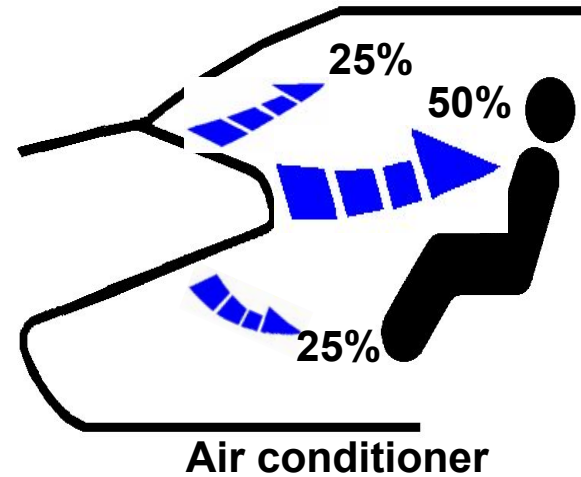
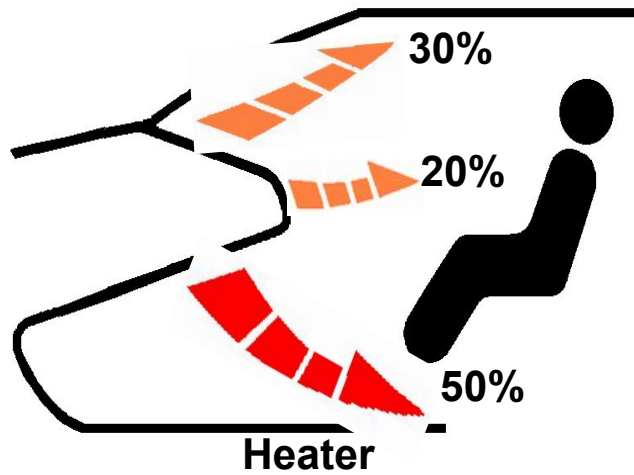



Button select	Air Mode	Function
A	Vent	Manual Mode
A + B	Vent + Floor	
A + C	Vent + Defrost	
B + C	Floor + Defrost	
A + B + C	Vent + Floor + Defrost	
D	Vent + Floor + Defrost	Auto Mode

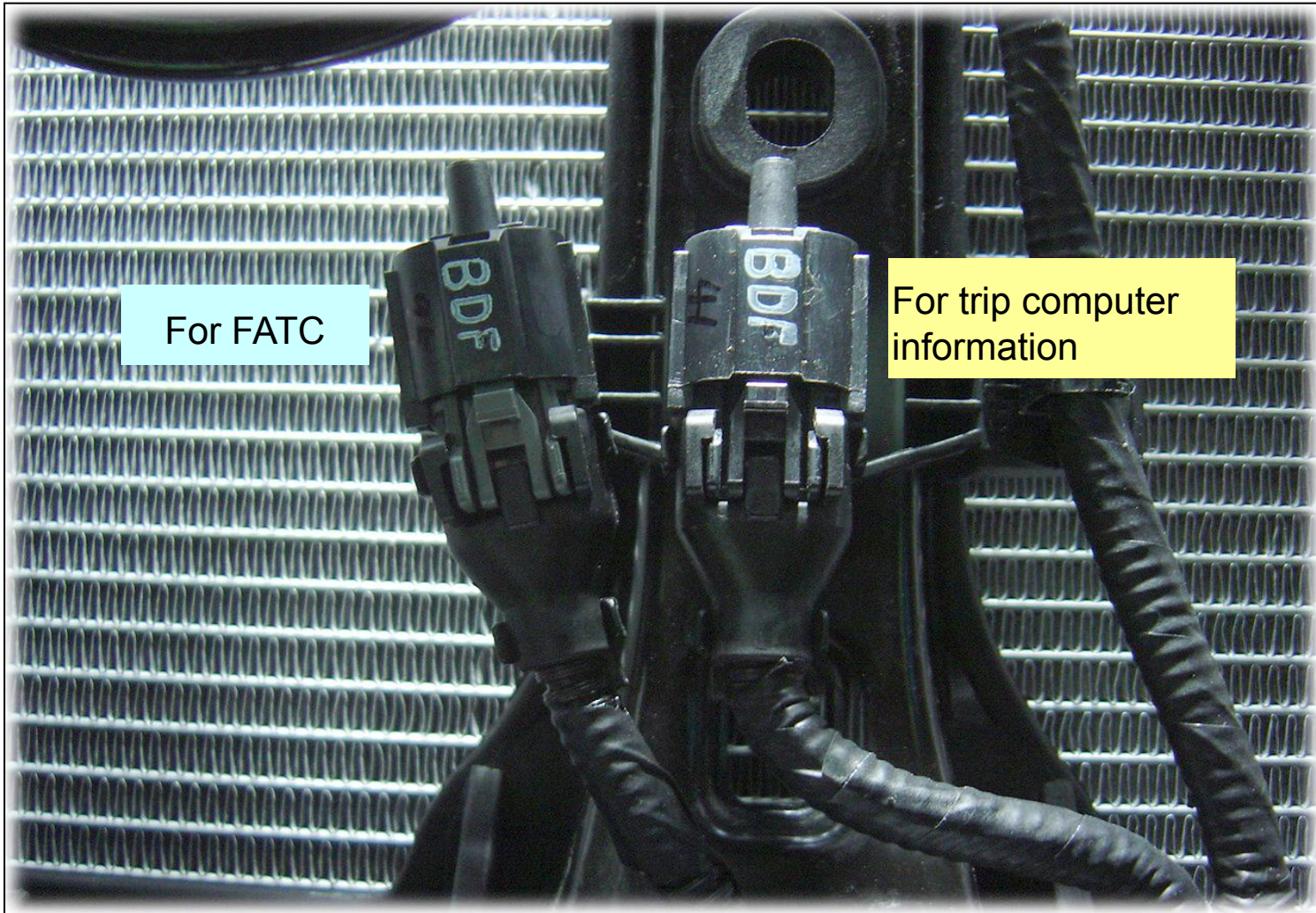

For FATC

For trip computer
information



- A. Select DEF. mode
- B. Push Intake button 5 times within 3 seconds
- C. See LED display of intake button flashes 3 times.
- D. Logic cancel & selection

User may choose the temperature indication between °C and °F.
Press the auto button for 3 seconds during pressing off button.
* Setting unit: °C (Battery disconnection)

2. Press auto button for 3 seconds or more



1. Keep pressing off button

The FATC module self diagnosis test feature will detect electrical malfunction and provide error codes for system components with suspected failures



DTC12	Description	Failsafe
00	Normal	
11	In-car temperature sensor open circuit	25°C Fixed
12	In-car temperature sensor short circuit	
13	Ambient temperature sensor open circuit	20°C Fixed
14	Ambient temperature sensor short circuit	
15	Water temp. sensor open circuit	- 2°C Fixed
16	Water temp. sensor short circuit	
17	Evaporator sensor open circuit	- 2°C Fixed
18	Evaporator sensor short circuit	
19	Temp actuator feedback line short or open	Setting temp.:15 ~ 22.5°C Max cool Setting temp.:23 ~ 30°C Max hot
20	Temp actuator failure	
21	Vent mode actuator feedback line short or open	If indicator is off : Close If indicator is on : Open
22	Vent mode actuator failure	
25	Intake actuator feedback line short or open	At FRE mode : Fresh mode fixed At REC mode : REC mode fixed
26	Intake actuator failure	
27	AQS sensor open	
28	AQS sensor short	
31	AQS sensor failure	
34	Floor actuator feedback line short or open	If indicator is off : Close If indicator is on : Open
35	Floor actuator failure	
36	DEF actuator feedback line short or open	If indicator is off : Close If indicator is on : Open
37	DEF actuator failure	

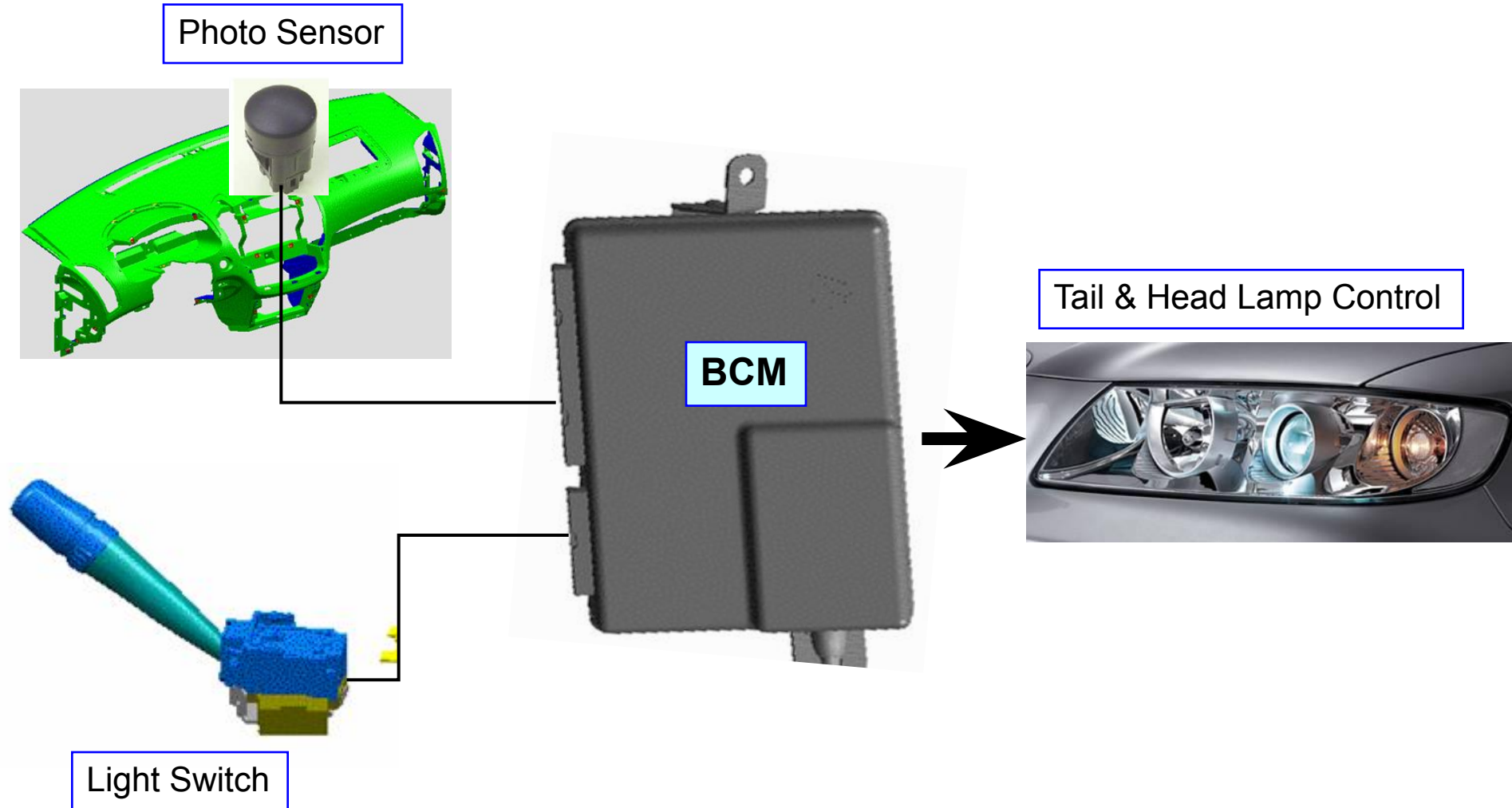

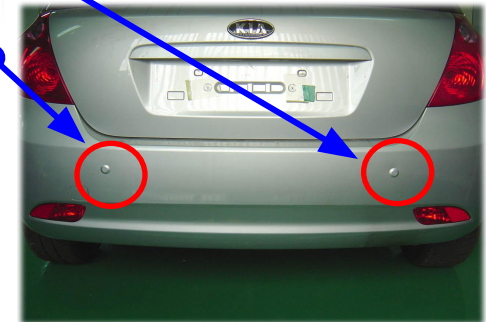
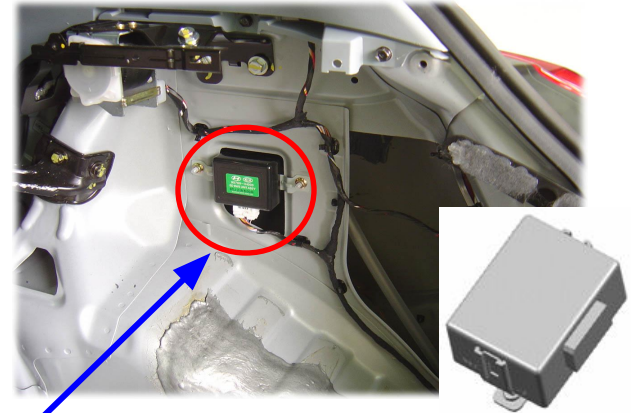
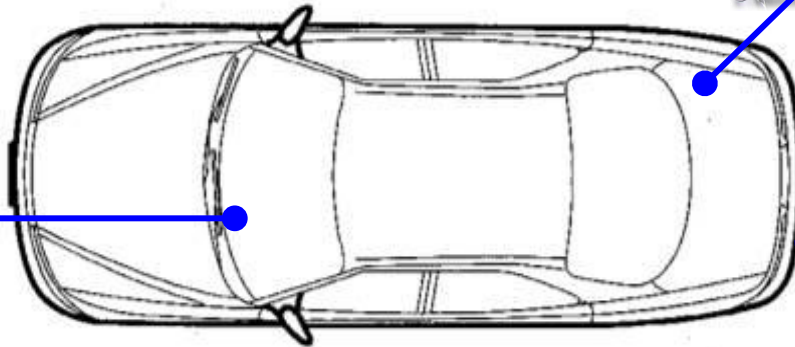
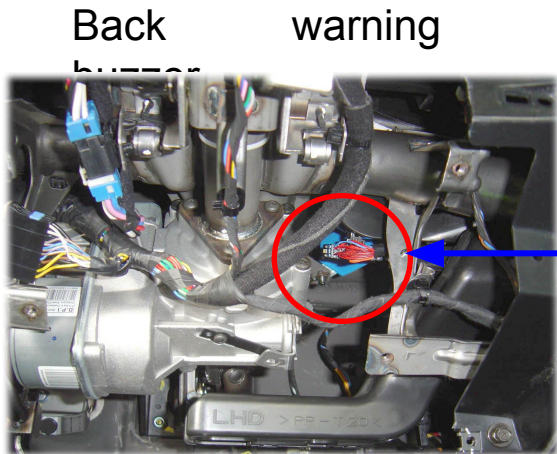





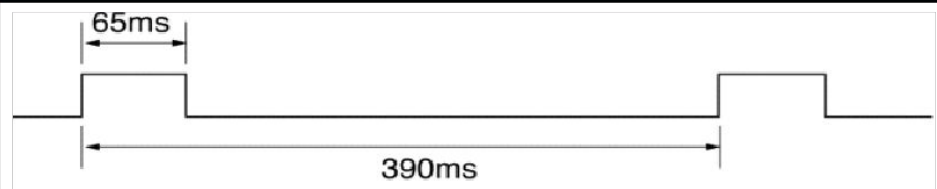
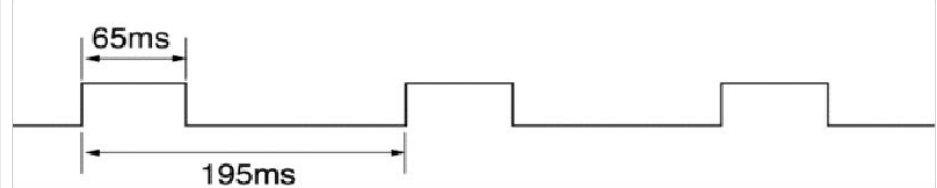

Ultrasonic sensor



The warning is generated when the object is closed to the rear sensor of the car as follows.

Step	Rear Left, Rear	Side LH, RH	Distance difference	Warning method (difference : ±10%)
1 step	81 - 120 (cm)	None	± 15cm	
2 step	41 - 80 (cm)		± 10cm	
3 step	below 40(cm)		± 10cm	

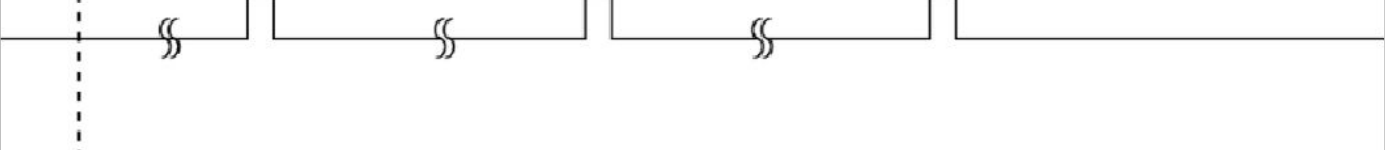
After electric power is supplied, if the gear shift is set in the rear (“R”) position, the following warning sounds are generated in according what sensor is malfunction.

Condition	Warning method (time difference : ± 10%)
Power ON	
Normal	
Rear left sensor failure	
Rear right sensor failure	

All door safety power window.

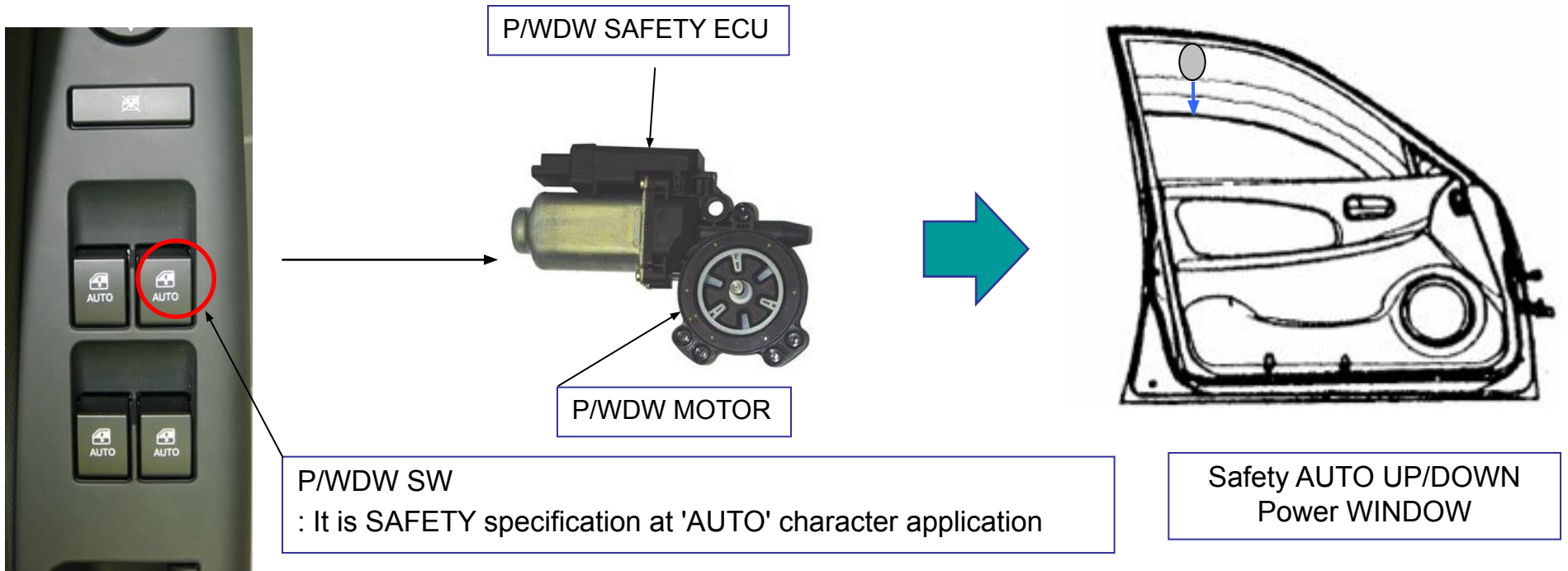

1. 개요

- ONE TOUCH OPEN & CLOSE 기능 : 스위치 1회 조작으로 글라스 전개 및 전폐 기능
- ANTI-PINCH 기능 : AUTO CLOSE 동작 중에 이물질 또는 신체의 일부가 끼었을 때 작동을 멈추고 열어주는 기능
- SURFACE GLASS 적용 : 루프 SKIN과 일치하는 글라스 적용
- 대형 와이드 루버 적용

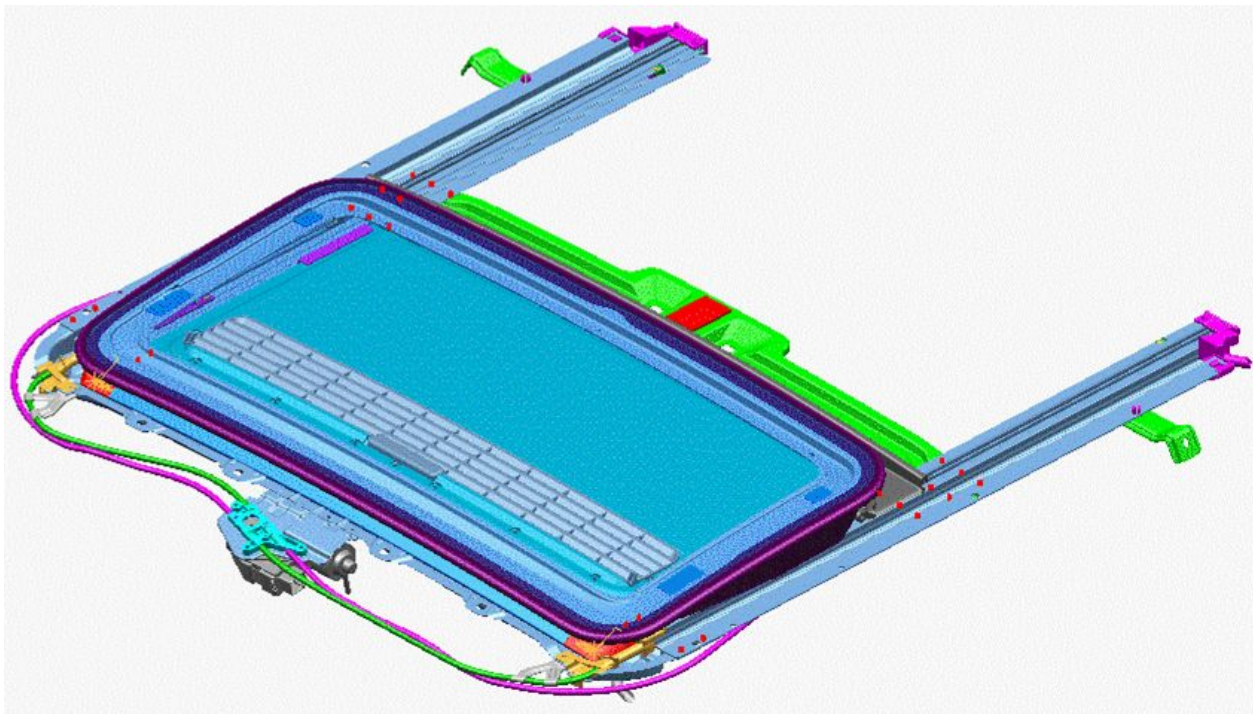

Monitor Display Item

- Trip Information
 - DTE (Distance to Empty)
 - Elapsed time
 - Average Speed
 - Average Fuel Consumption
 - Instant Fuel Consumption
- Date, Ambient temperature, Clock,
- Audio information
- Door open/closed indicator
- TPMS information
- LH/RH Brake stop lamp fail information
- Freezing warning

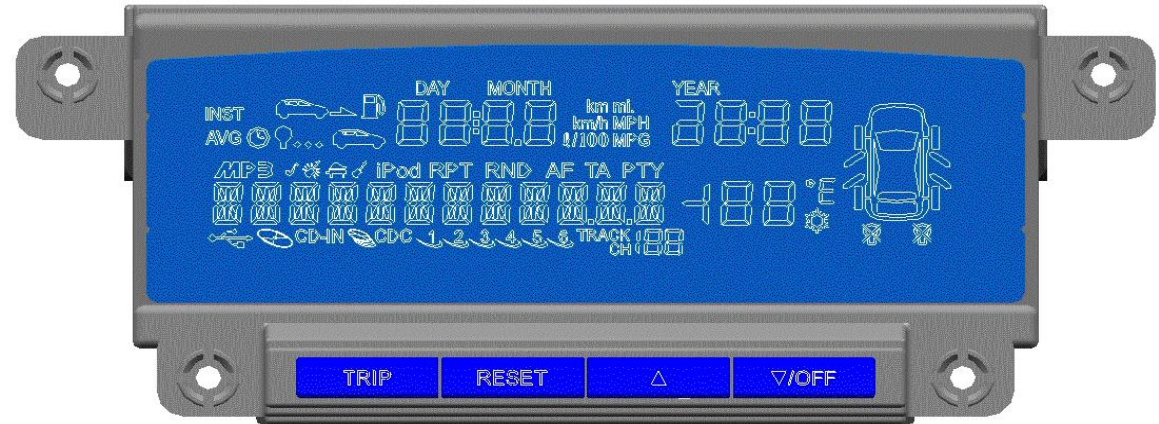

Input Signal

- Battery Back up
- Ignition
- Illumination
- Ambient Temp Sensor
- Injection Signal**
- Fuel Sender**
- Tachometer**
- Vehicle Speed Signal**
- Door Switch(4Door)
- Tail Gate Indicator
- Stop lamp Failure

- CAN information
 - Audio Information
 - TPMS Warning



Output Display

- Trip Information
 - DTE (Distance to Empty)
 - Elapsed time
 - Average Speed
 - Average Fuel Consumption
 - Instant Fuel Consumption
- Date, Ambient temperature, Clock,
- Audio information
- Door open/closed indicator
- TPMS information
- LH/RH Brake stop lamp fail information
- Freezing warning

Trip information

Calendar & Clock

TPMS, Door open,
Brake lamp failure
information

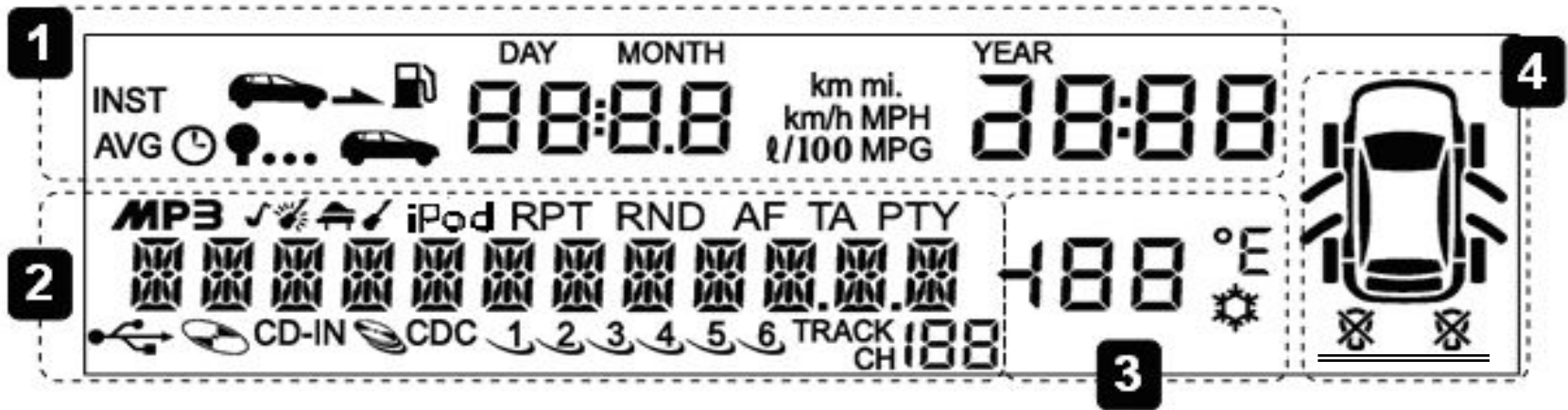

Audio information

Ambient temperature
Freezing warning
information

Road freezing
indicator
(-5 ~ 3°C)

Brake lamp
failure
indicator

- Connection Input Source

- Vehicle Speed Sensor

- Tachometer

- Injector Pulse(80mCC/1 Pulse)

- Fuel Sender



- **Data Storage**

DTE data is not saved in the EEPROM. Battery discharge or disconnection will cause DTE data loss. After this Reset Condition, a new DTE value will be calculated based on the amount of fuel in the tank and a default fuel consumption value.

※ Default Fuel Consumption : 8ltr/100km.

- **Calculation of Distance To Empty (DTE)**

The distance to empty is calculated from the remaining fuel and the fuel consumption.

- ▶ Calculation Input source : Fuel sender signal and average fuel consumption (AFC)

$$\text{DTE} = (\text{Fuel Volume} - \text{DTE offset}) / \text{CFC}$$

DTE = Distance to empty [km or miles]

FV (Fuel Volume) = Remaining fuel volume of tank

AFC = Average fuel consumption [l/100km]

DTE offset = Offset for the indication

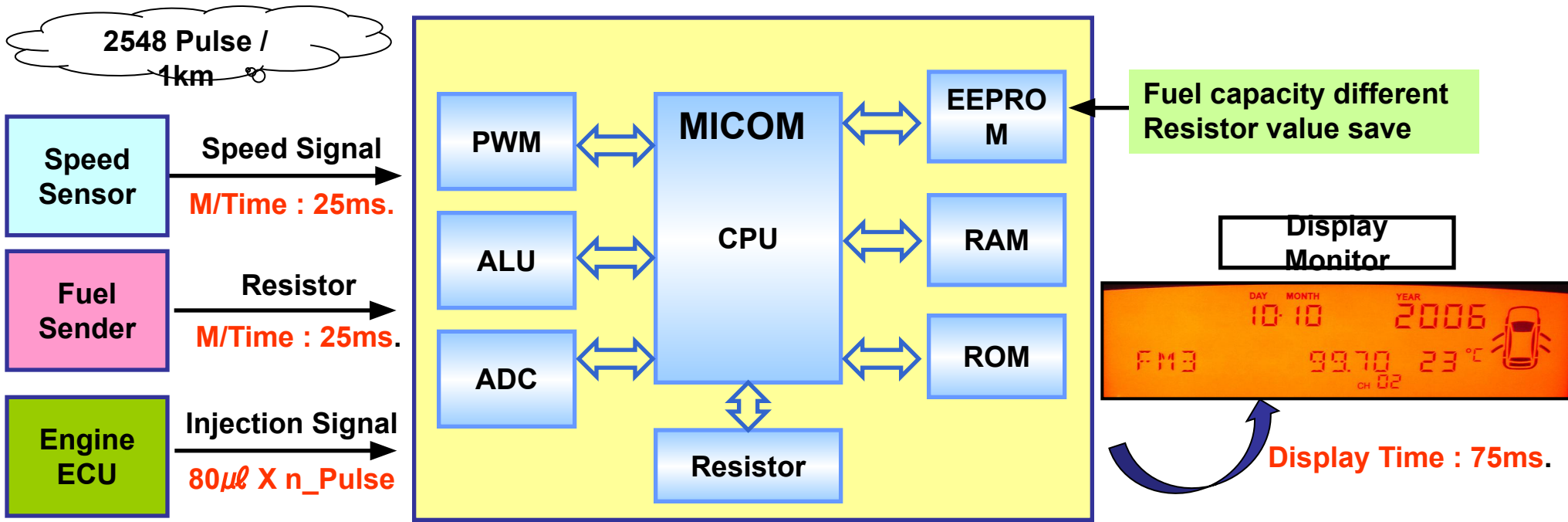

Max. 5 Pulse/10ms

★ M/Time : monitoring Time

Distance to Empty Calculation

■ KPH

$$DTE (km) = \frac{\text{Speed Pulse}}{80\mu l \times n \text{ --- Pulse}} \times \text{Fuel Volume}$$

■ MPH

$$DTE (mile) = \frac{\text{Speed Pulse} \times 3.78543}{80\mu l \times n \text{ --- Pulse} \times 1.609} \times \text{Fuel Volume}$$

AFC data

In case Normal

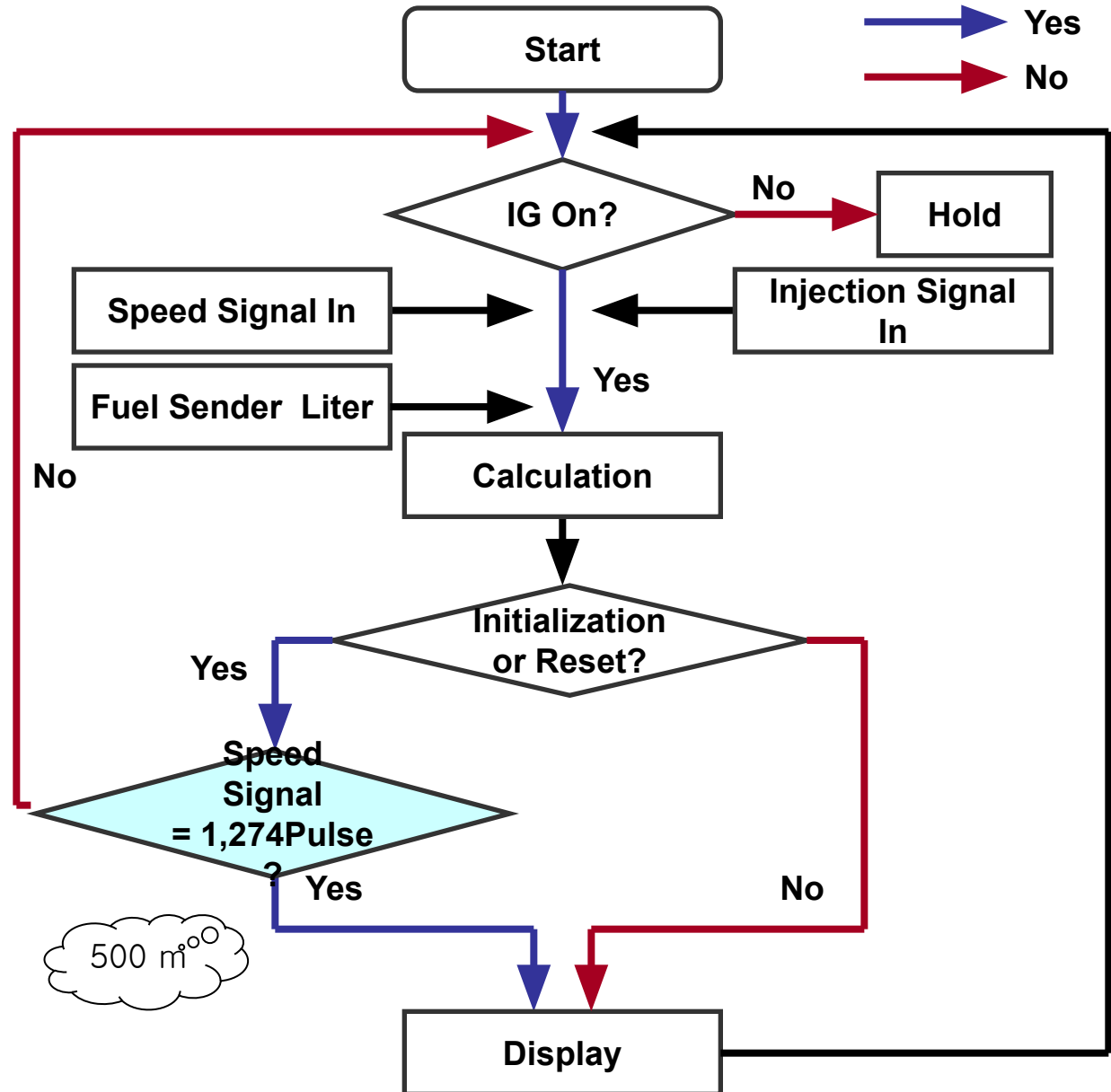

- © Fuel Consumption data use: data of before IG. off
- © Data regeneration : after drive 500m

500 m

In case of Battery terminal removed

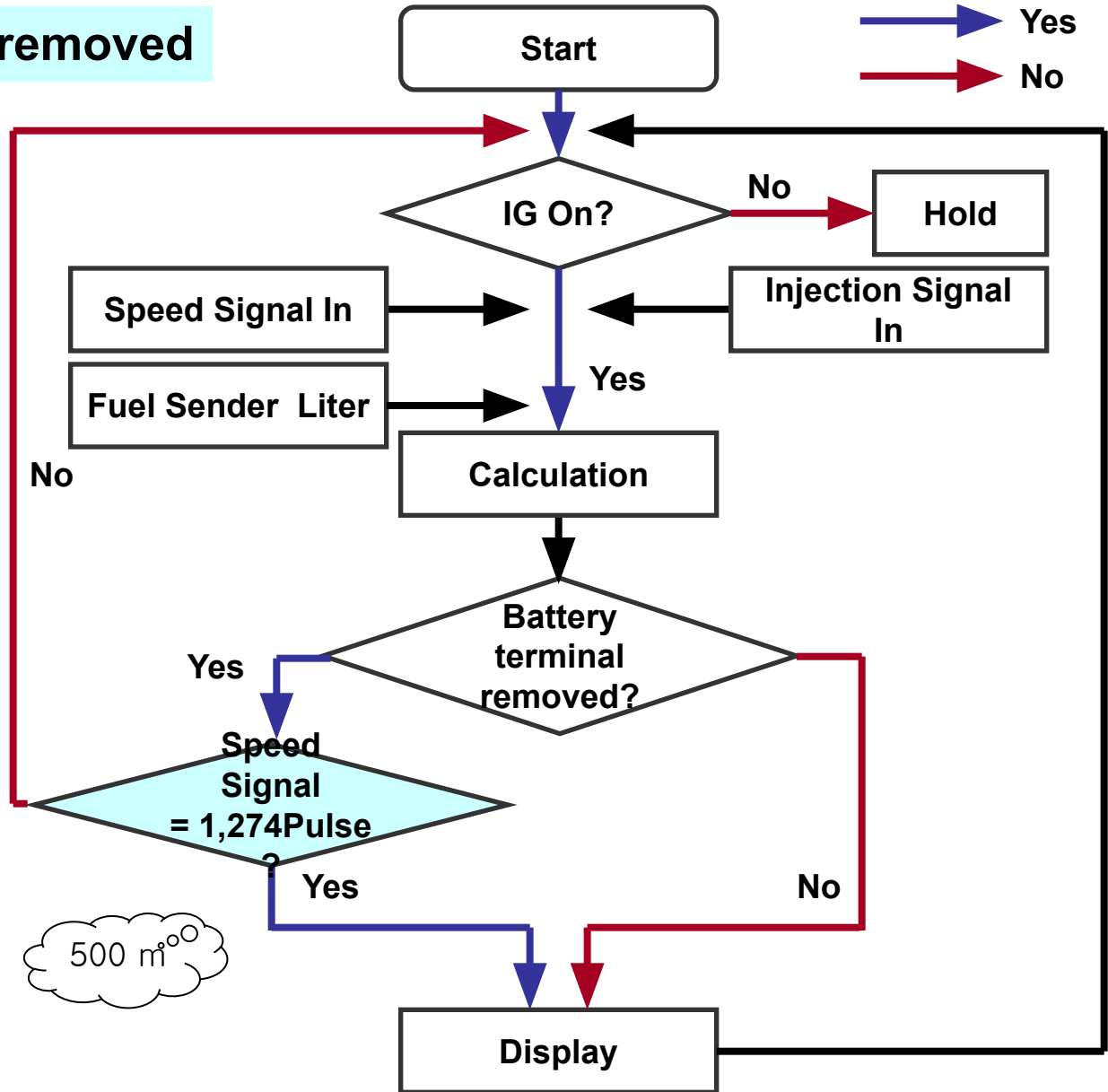

- © Fuel Consumption data use: data of default F/cconsumption (13.2liter/100km)
- © Data regeneration : after drive 500mm

500 m⁰⁰

§ Fuel charged with key Off : Fuel charged while key off and key ON

If there are more than 6 liter changed of fuel amount with key IG. Off, and key ON :

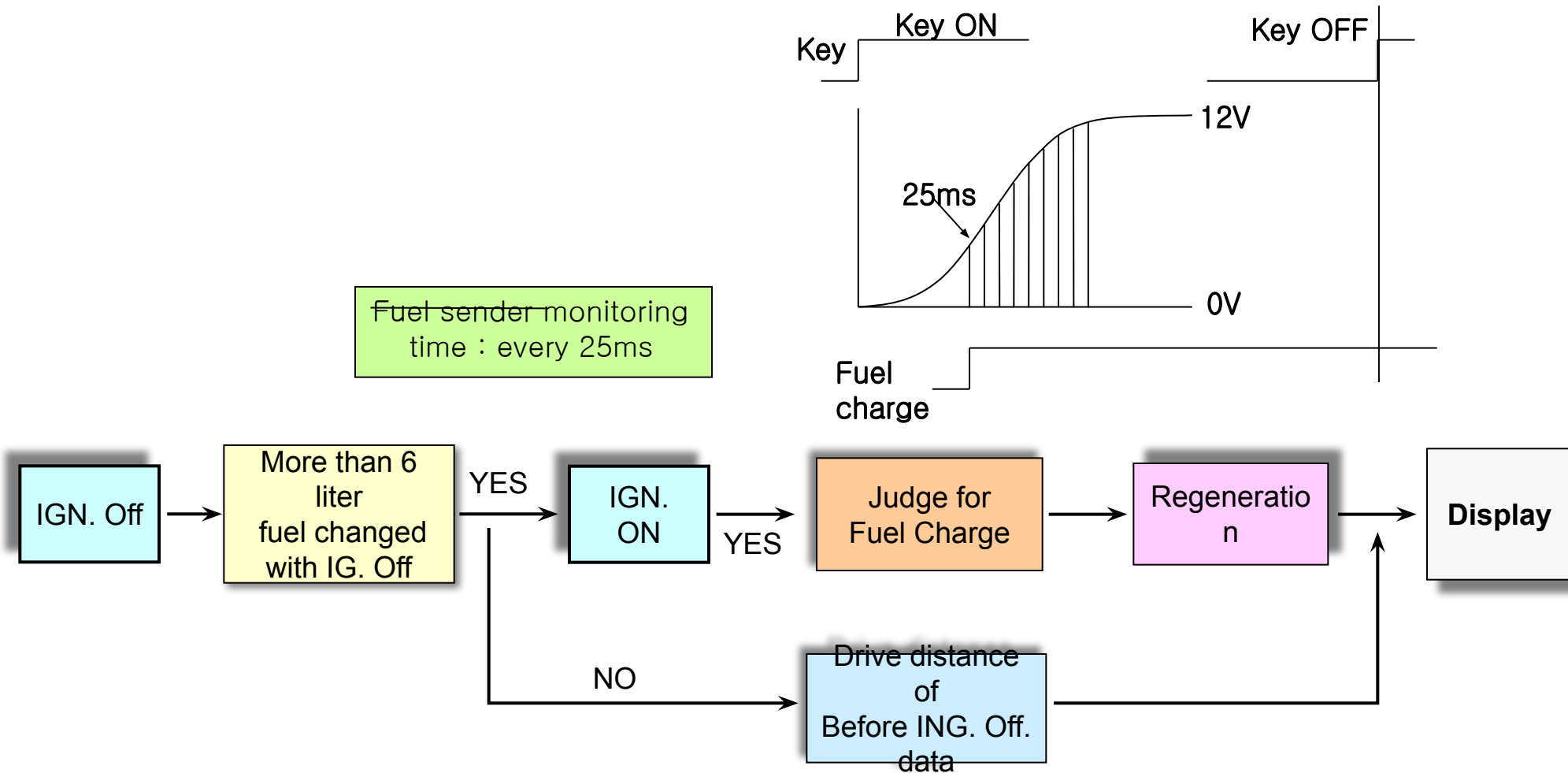

§ Fuel charged with key ON : Fuel charged with Key ON

If there are more than 6 liter fuel amount changed during IG. ON. ECM recognizes fuel supply and modifies DTE value.

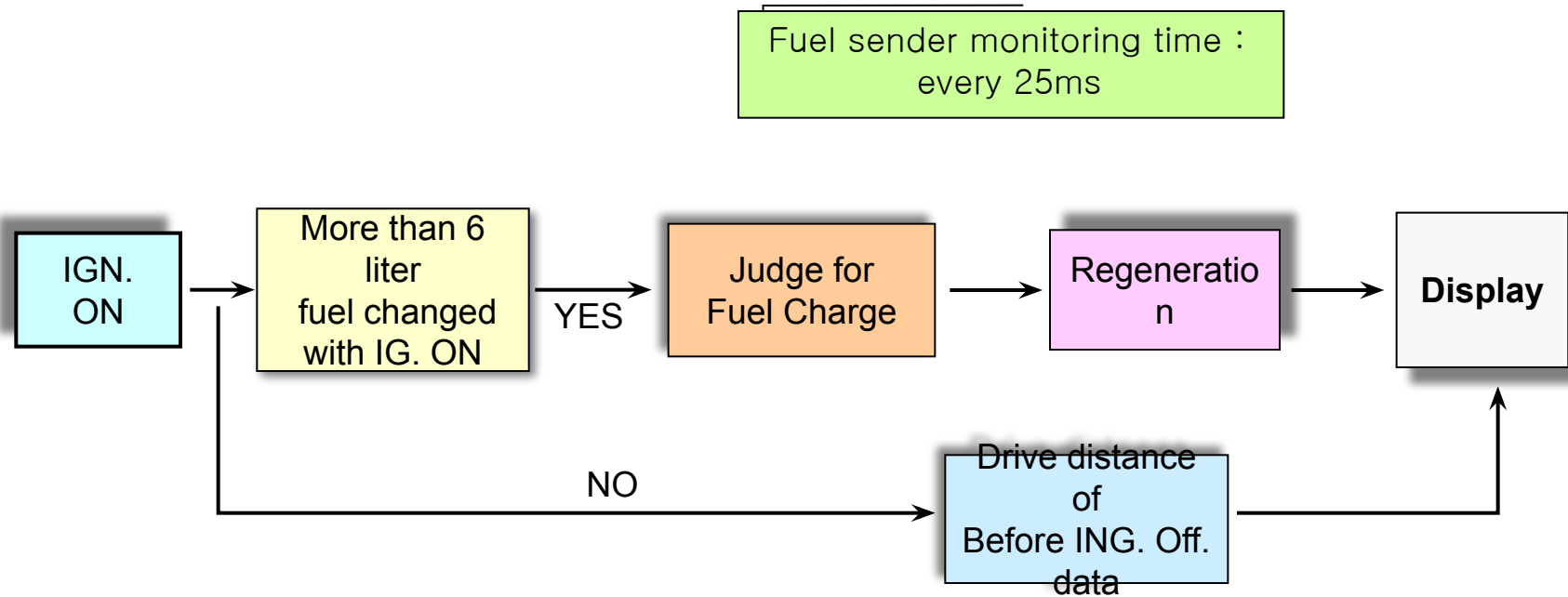

- ◆ ”- - - -“ **flashes with 1 Hz** : DTE calculation data less than 50 km or 30 miles
- ◆ ”- - - -“ **DTE segment stay ON** : Fuel sender input is out of range for more than 20 sec.
(Ex : short circuit or open input)

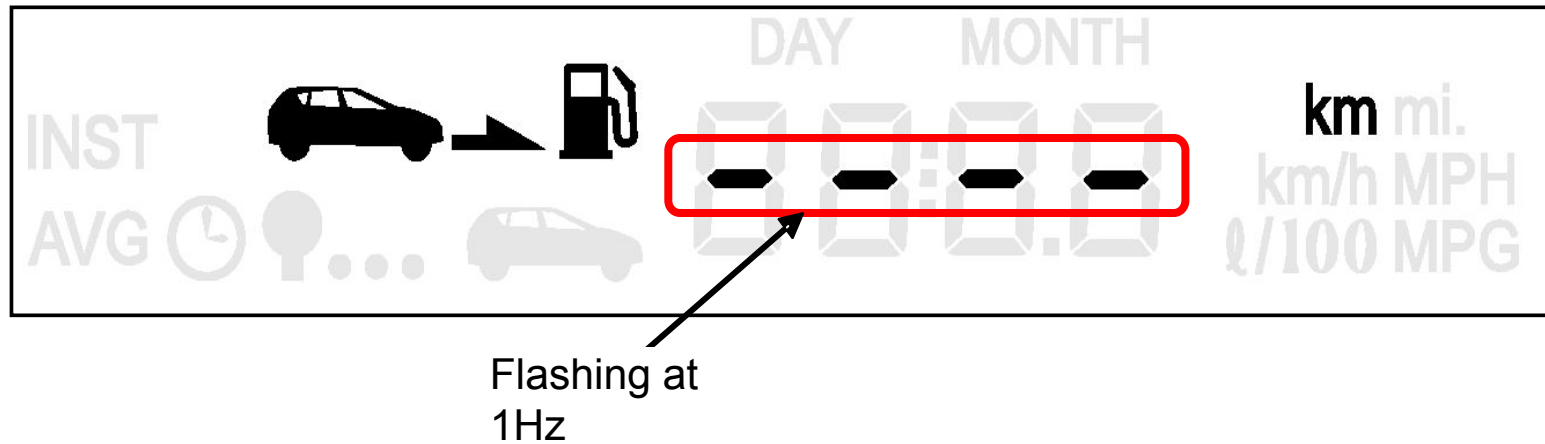

- ◆ Input signal fault
 - Injection signal : DTE data move to 00liter/100km
 - Vehicle speed signal : DTE data move to 99.9liter/100km

The Elapsed Time shows the time in hours and minutes (hh:mm) that the ignition has been switched on and the engine is running since the last DTE reset.

Input : Engine rpm & Internal clock

Range : 0:00 to 99:59

Error Rate : under 0.1%

Resolution : 1 minute

Data Storage : DTE data is not saved in the EEPROM.

Battery discharge or disconnection will cause DTE data loss (reset to 0:00).



Input source : Tachometer vehicle speed and internal clock counter

Display range : 0 to 260kph or 160 mph

Resolution : 1 kph or mph

Error Rate : under 1.0%



- **Input source** : Injection signal & Vehicle speed signal
- **Data regeneration after reset** :
 - 500m derived : Data regeneration
 - there is no signal input after 500m derived : Data displayed “-- --”.
- **Data regeneration when Input signal faulted.**
 - Injection signal : DTE data move to 00liter/100km
 - Vehicle speed signal : DTE data move to 99.9liter/100km

※ Calculation Formula

Average fuel consumption = Driving distance (VSS) ÷ Injection signal (n --- pulse X 0.08 cc)



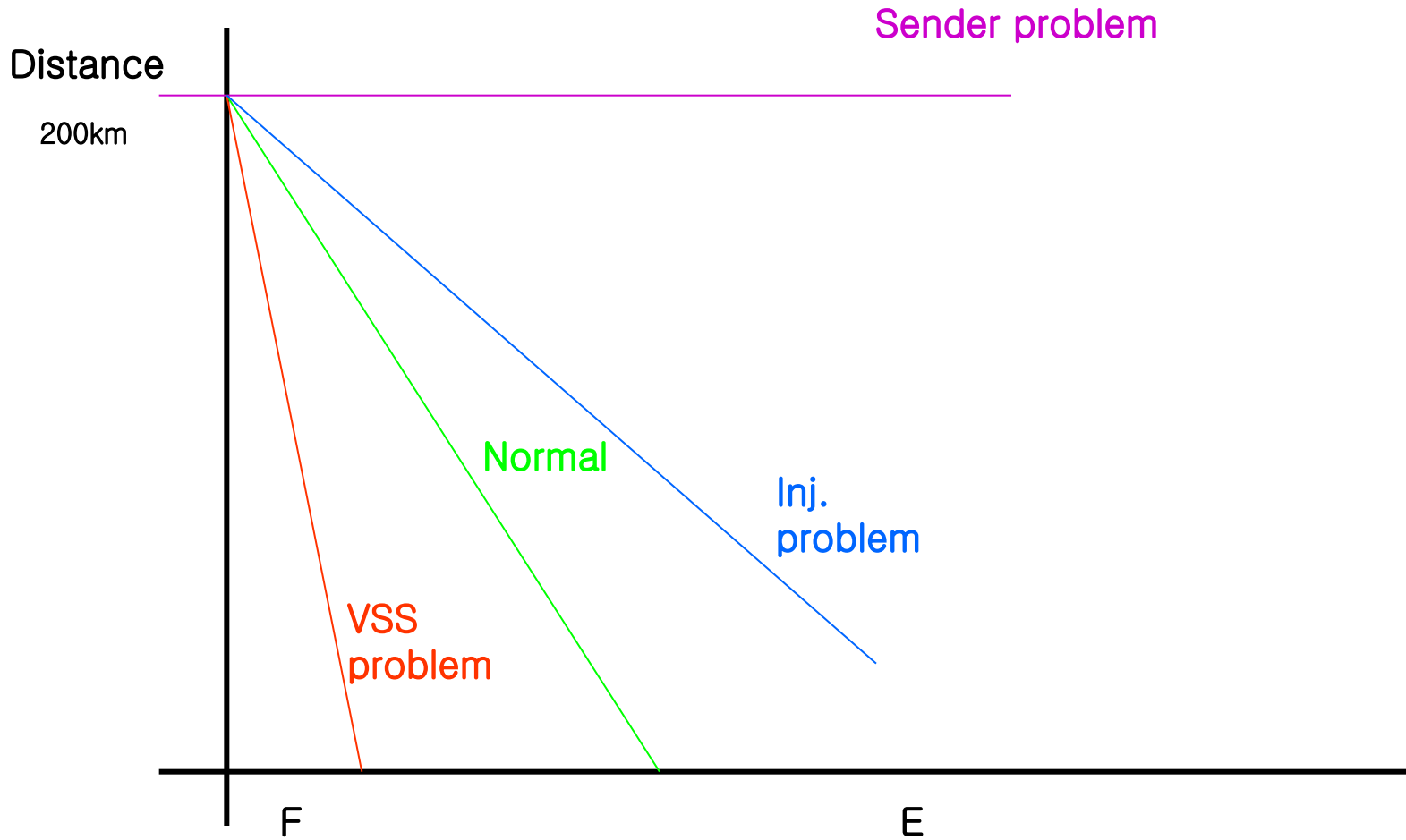

The microprocessor calculates the instantaneous fuel consumption from the instantaneous fuel used and the distance that the ignition has been switched on. The instantaneous fuel used is calculated from the fuel consumption input.

- Update time : 2 seconds
- If speed is below 30km/h, IFC is displayed "-.-"

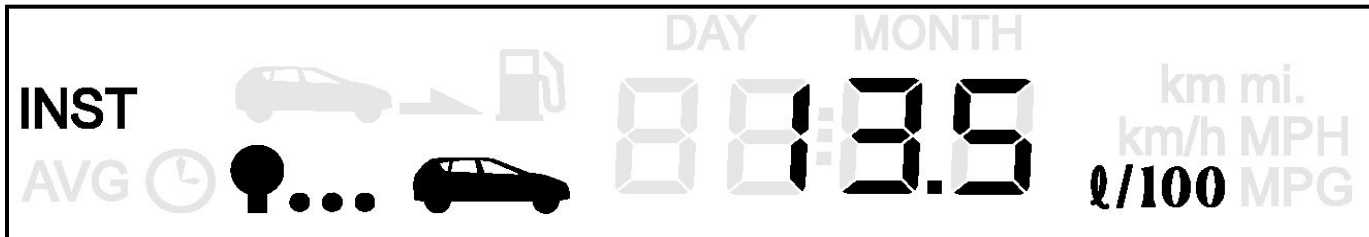

◆ Fuel Consumption

Press “UP” button more than 2 seconds



◆ Ambient temperature

Press “DOWN” button more than 2 seconds



- ▣ Front Wiper control
 - Washer & wiper lineage control
 - Variable INT. wiper control
- ▣ Rear wiper & washer control
 - Rear INT. wiper control
 - Rear washer interlock rear wiper control
- ▣ Chime bell warning
 - Driver's seat belt reminder control
- ▣ Rear defogger control
- ▣ Front deice timer control
- ▣ Lamp control
 - Decayed room lamp control
 - Tail lamp auto cut
 - IG. Key hole illumination
 - Rear & front fog lamp control
 - Auto light control
 - Head lamp escort control
- ▣ Door lock/unlock control
 - Central door lock/unlock control
 - **Central door lock/unlock indicator**
 - **Reminder unblock control by C/door lock S/W**
 - IG key reminder
 - Impact sensing door unlock
 - Speed sensing auto door unlock
 - Auto IG key off unlock
 - Dead Lock/Unlock control
- ▣ Power window timer control
- ▣ Anti-theft function control



◎ Input signal senses using 2 kind of voltage.

- 5 volts
- 12 volts

◆ In case of recognize signal using 5 volts.

1. Awareness voltage of switch are output from BCM
If switch turned ON, BCM output voltage drop to 0 volts .
And, tail lamp relay turn "ON"
2. At this time, when switch turned ON
BCM recognizes switch signal though voltage drop is below than 1volt (Low signal)
3. If switch turned off, the voltage going up to high lever.
At this time, voltage level that recognize switch off signal is higher than 4volts.
4. Thus, the switch signal is not recognize voltage between 1.1 volts and 3.9 volts.

◆ In case of recognize signal using 12 volts

- Extent that recognize switch's on/off signal is
- ON : lower than 4 volts (Low signal)
 - OFF : higher than 7 volts (High signal)

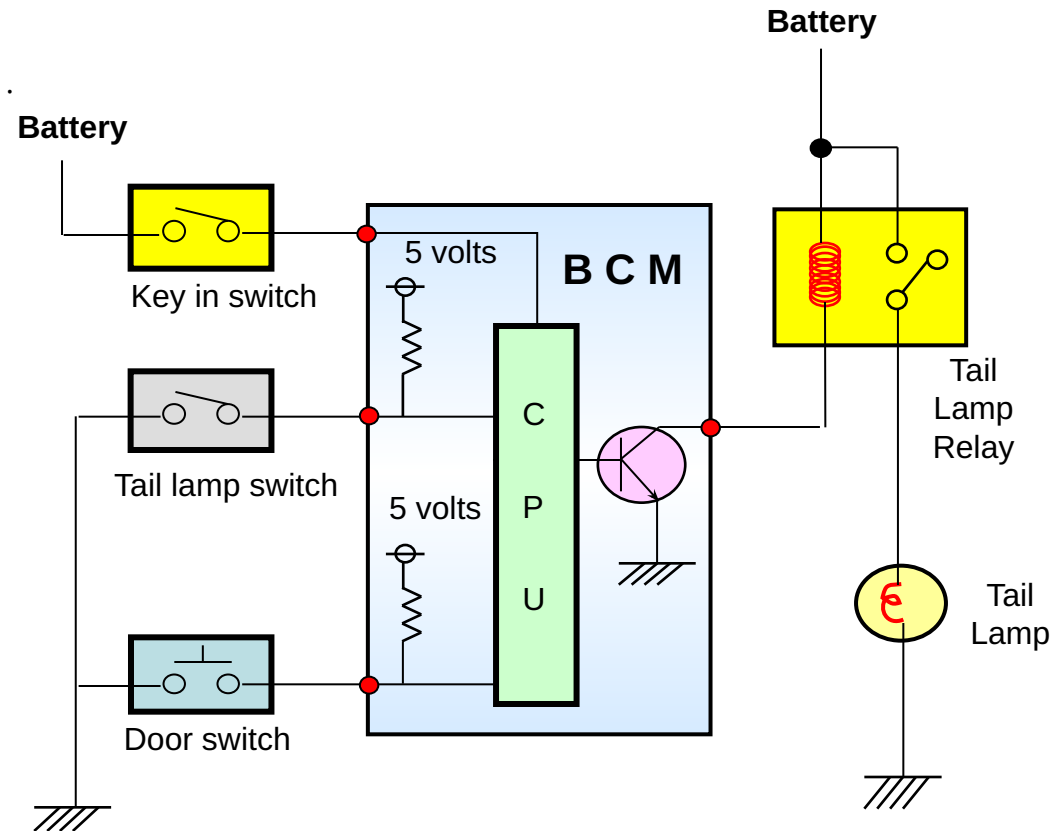

Description

By adopting the auto light sensor, the tail lamp and head lamp will be turned ON or OFF automatically according to the surrounding brightness.

Auto Light function condition.

1. Ignition Key S/W "ON"
2. Light S/W "Auto Position"

	Tail Lamp	Headlamp
ON	$0.81V \pm 0.08V$	$0.36V \pm 0.06V$
OFF	$1.41V \pm 0.10V$	$0.51V \pm 0.06V$

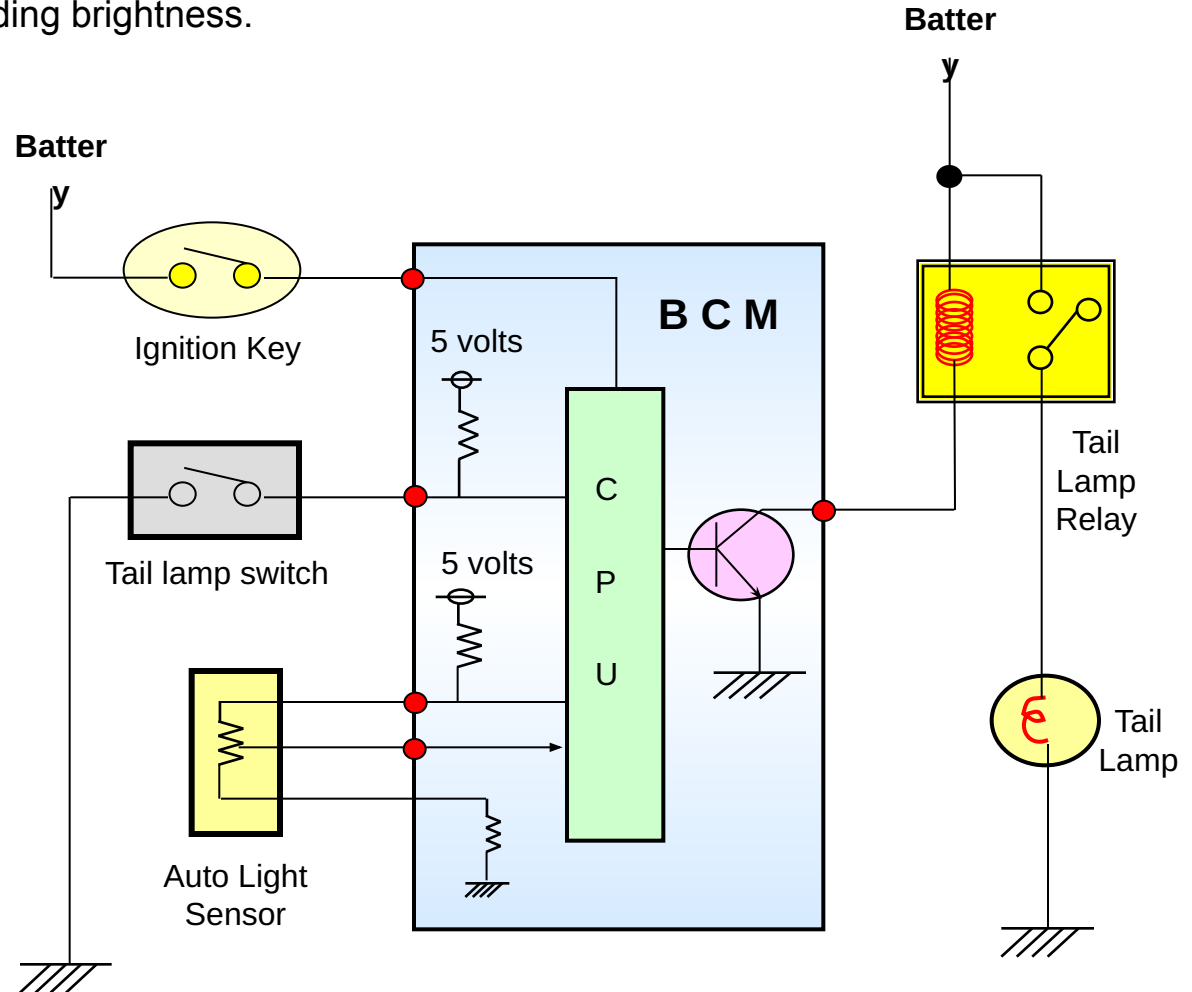

When door unlock switch is turned to Lock when ignition key is removed from the key cylinder and driver door is opened by central door lock / unlock switch, keyless or door key switch, the door unlock relay outputs for 1sec after 0.5sec.

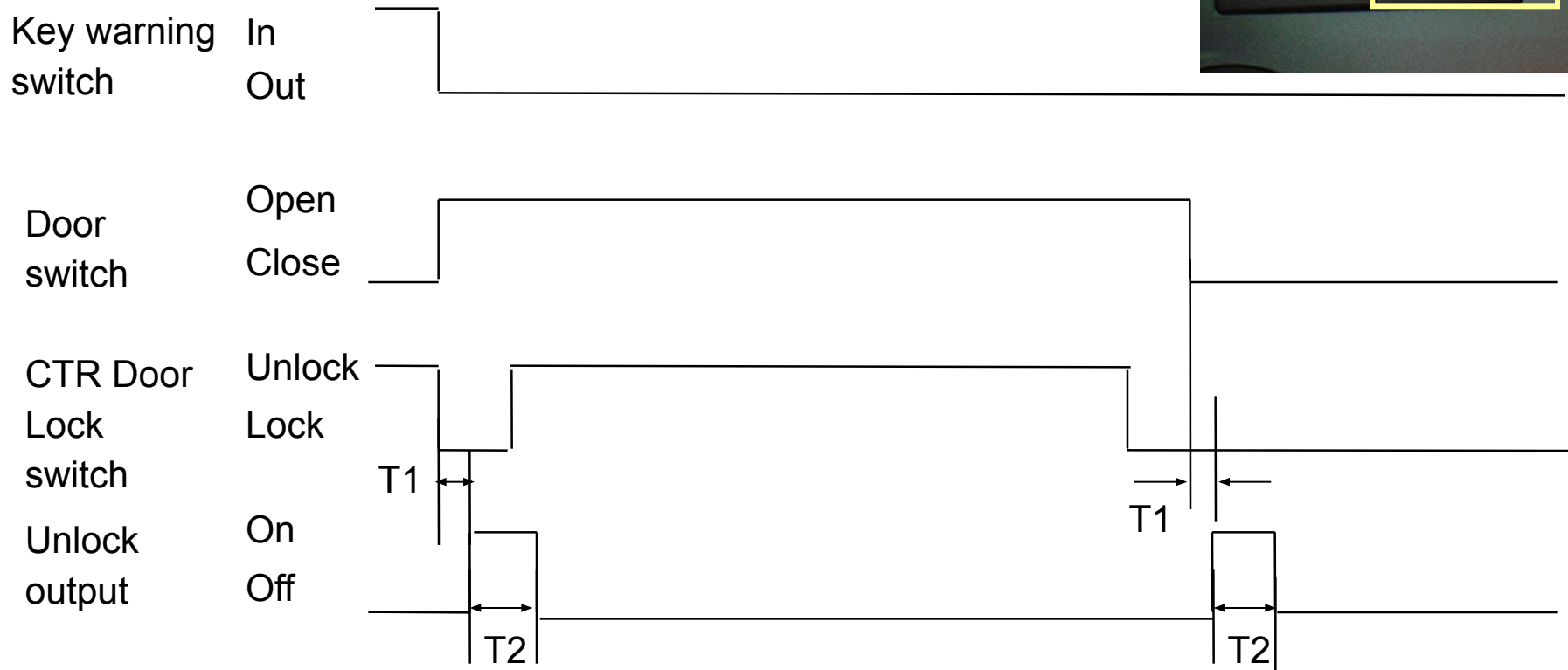
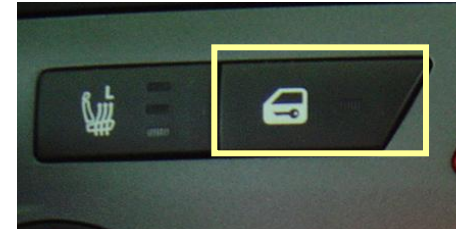

T1: 0.5s ± 0.1s T2: 1s ± 0.1s

