

**RUSSIAN
EXPORT CENTER**

**INTERNATIONAL ONLINE
BUSINESS MISSION
RUSSIA - VIETNAM**

**15.04.2021 –
15.05.2021**





AGROINDUSTRIAL COMPLEX



RUSSIAN
EXPORT CENTER



GALACTICA LLC

Health-giving products



St.Petersburg



mnogomoloka.ru

▶ MAIN DIRECTIONS

Galactika Group is one of Russia's largest independent producers of dairy products. Our core mission is to encourage our consumers to embrace a healthy lifestyle and care for their well-being by offering them natural, high-quality and delicious dairy products.

▶ PRODUCTS

The best-quality milk sourced from farms located in Leningrad and Kirov Regions is used in our production.

▶ BENEFITS

Highest quality standards, international certification ISO 9001; 100% automatization of all technological processes; our dairy products have the shortest way from the cow to the consumer.





RUSSIAN
EXPORT CENTER



KPK LLC

is one of the largest food manufacturers in the Krasnodar Territory. The main goal of the company is direct distribution (contract and own production) and logistics of food products in retail and wholesale through our own trade department.



Korenovsk city

www.kpk.group

MAIN DIRECTION

sunflower seeds processing

PRODUCTS

sunflower oil, halva production, kozinak production (peanut, sesame, sunflower)

BENEFITS

- High degree of cleaning
- Natural ECO product without Preservatives and oxidizers
- Only the largest selected grains





RUSSIAN
EXPORT CENTER



BOMBBAR



Tolyatti

www.bombbar.ru

manufacturer of the most useful products
for body and health maintenance

MAIN DIRECTION

chikalab manufacturer; production of high quality free sugar products

PRODUCTS

sweets, snacks, and quick meals are made using water – soluble corn fibers, milk protein, and whey protein, protein bars, vegan and fitness cookies, low calories jams, toppings and sauces

BENEFITS

- natural product
- helps to reduce weight
- satiates
- nourish muscle mass
- helps maintain normal blood sugar level





RUSSIAN
EXPORT CENTER



AGROSOUZ LLC



Tambov

www.agrosouz.net

the multi-branded company was founded in 2003.
It is a manufacturer and distributor of snack products.

MAIN DIRECTIONS

manufacturer and distributor of snack products

PRODUCTS

products from sunflower and pumpkin seeds, peanuts and natural sweet brittles

BENEFITS

- High margin product
- Product with high shelf life
- Healthy and nutritious product containing a lot of vitamins
- Competitive product
- Margin of the distributor (up 15-25%)
- Adapted to all sales channels





RUSSIAN
EXPORT CENTER



Russian Caviar House
Group of Companies

RUSSIAN CAVIAR HOUSE GROUP OF COMPANIES



Vologodskaya obl.



www.russian-caviar-house.ru

a manufacturing company has been operating since 1978 and has become the largest caviar-producing one in Russia

▶ MAIN DIRECTION

the company has developed productive breeding stocks, which today produce caviar, fish seed and consumer fish products

▶ PRODUCTS

black caviar

▶ BENEFITS

the company uses cutting-edge technologies and research, which allow to keep the fish in comfortable conditions, as close to their natural habitat as possible





RUSSIAN
EXPORT CENTER

Си-Проджект

Производственный холдинг

C- PROJECT LLC



Saint Petersburg



www.c-project.ru

C-project was founded in 1995 and is a big Petersburg's food holding. The company produces of high- quality food products by all family, has a many years experience cooperate with the main retails and dealers of Russia and other countries

▶ MAIN DIRECTIONS

is an actively developing food holding. It keeps to the up-to-date business principles and offers open relations with its partners

▶ PRODUCTS

healthy food, instant food, canned food, snacks

▶ BENEFITS

- attractive pricing
- vegan and lactose – free
- free from artificial colors, flavors, preservatives and palm oil





LLC MNK

Chernogolovka is the leading Russian FMCG group of companies. Chernogolovka is the number 1 for 20 years since 1998 in non-alcohol beverages, since 2017 in snacks, since 2019 in confectionery. Own the factories and water wells. The high quality of products is confirmed by numerous awards from prestigious international and Russian competitions, including the government awards in the field of quality.



Moscow

chernogolovka.com

MAIN DIRECTIONS

Production of non-alcohol beverages, snacks

PRODUCTS

Chernogolovka -sparkling drinks (11flavors).

The Baikal brand -soft drinks. Juicy ripe cherries, fragrant raspberries, refreshing lemon, Serbian herbs and artesian water create unique flavors.

Fantola - bubble gum, mango, pineapple and etc.

Water from the famous Baikal lake / carbonated and non-carbonated water.

Energy drinks(TURBO) and energy in the new form of energy

Chips and snacks salty and natural.

Candies Savinov: pralines, fondant, jelly, soufflés

Biokey cereal bar(contain natural ingredients: cereals, fruits, berries, seeds)

BENEFITS

- The quality control system for raw materials and finished goods meets the most strict international quality standards.
- They offer customers different shipping terms : FCA,DAP,CPT.
- Warehouse 24/7;20 loading gates; pallets with phytosanitary treatment; products 12 months shelf-life, labelling according to customers requirements.

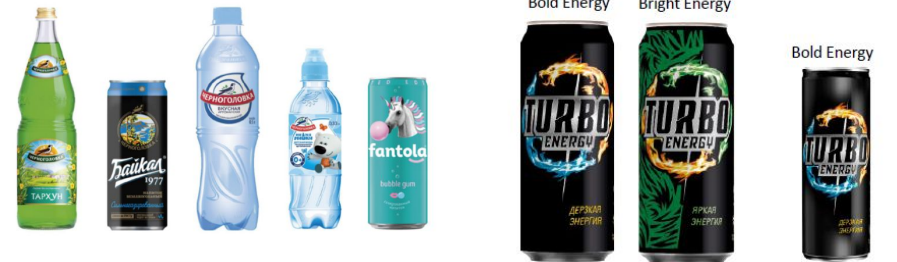



RUSSIAN
EXPORT CENTER



LLC PERONI

Created a new niche -honey-souffle (cream-honey) with additives. Honey became a delicacy and a delicacy. And this is only the beginning. We consider that such a useful and tasty product as honey-souffle should become an integral part of consumption in every family. Technology for obtaining honey-souffle was invented in Canada by professor of beekeeping J.J. Dyson. Honey is mixed for a long time in a certain mode, after which it is kept at low temperatures, thereby forming and fixing its delicate consistency.



Moscow



www.peronihoney.ru

▶ MAIN DIRECTIONS

Production of Niche -honey-souffle

▶ PRODUCTS

- Niche -honey-souffle (cream-honey) with additives(22 tastes)
- Chocoballs with chocolate
- Eco- candles and honey soap
- Pure honey "HONEY GOLD"
- Vintage tea
- Sugar with juice

▶ BENEFITS

- All the useful properties of honey are preserved, as the temperature regime is strictly controlled.
- Modern production, unique production technology, certified by European technologists.
- The products are certified according to European and world standards, and independent quality control system - "Biological safety".





RUSSIAN
EXPORT CENTER



LLC KONDITERSKIYE MOROZOVA

KONDITERSKIYE MOROZOVA is 23 years of excellent experience in industrial scales and exceptional quality. During this time we have gained the reputation of a sustainable, developing and good-running partner and dignified history.



Rostov-on-Don



www.pechenyemorozova.ru

MAIN DIRECTIONS

Production of biscuits of various flavors

PRODUCTS

- Biscuits (original, milk, cocoa)
- Oatmeal biscuits (OATMEAL biscuits are only 3cm in diameter, which makes them ideal for light snacks)
- Pekasso biscuits (banana puree, chopped coconut, fragrant honey and soft cream)
- FORMULA USPEKHA biscuits with cinnamon, papaver, combination of milk chocolate biscuits and spicy
- black sesame seeds and etc.

BENEFITS

- Factories with high - technology equipment from the world's leading suppliers and its constant modernization: «Donskoy Confectioner» LLC, «AKF» LLC, «BKF» LLC, «Pechenye Morozova»
- Biscuits contains natural oat flakes rich in fiber and vitamins.





RUSSIAN
EXPORT CENTER



CONFECTIONERY FACTORY TORERO



Moscow, Pavaletskaya
Embankment 2



www.torero.ru

Confectionery factory «TORERO» was established in year of 2002. More than 400 people work for the benefit of our confectionery factory. Production capacity, at present, is around 45 tons/a day. More than 300 product items are in the matrix



MAIN DIRECTIONS

Number 1 White & Private Label in the wafer product .Weight and packaged products in the assortment. Attractive brands and unique offer for products.

PRODUCTS

Wafers «Chocolate» Black Edition TM TOREROFF, Delicate mini-wafers TM «TORERO», Wafer Candies in glaze with chocolate taste TM «TORERO»

BENEFITS

Production capacity, at present, is around 45 tons/a day. More than 300 product items are in the matrix. Products are produced on four modern automated lines (Turkey).

Launch of a new building and fifth automated line with production capacity of 600 tons per a month in March 2019. High production technologies are implemented at the company. The own production lab is opened at the company from 2018.

There is a modern logistics center on the territory (warehouse for final products and raw materials). The company is FSSC 22000 certified / HALAL certificate.





LLC UNITRON PROM

Having entered the market 25 years ago, nowadays one of the largest manufacturers of nutty semifinished goods in Russia, the group of companies Unitron has been among the acknowledged leaders in food ingredients processing and supply for food industry. The company develops, produces and supplies natural nuts ingredients providing its customers to reduce the cost of finished goods and create new products.



Penza



www.utr.ru

MAIN DIRECTIONS

Manufacture of nuts products

PRODUCTS

Roasted nuts and seeds for baked goods, confectionery and ice-cream manufacturing: whole nuts, halves, diced nuts, grind nuts (butters), nuts with sugar (roasted caramelized nuts), nuts with natural juices, chopped nuts (sliced / slivered).
Natural nuts, nuts with spices, nuts for cooking (toppings, fillings, decoration), nut cream and nut phaste, nuts and seeds butters (spreads), peanut sauces, peanut butter

BENEFITS

- The range of products developed by the company since its foundation makes up more than a hundred of items.
- Registered at the Sedex platform. Approved by the SGS certification system.
- Own chemical and microbiological laboratory.





MAKFA

Pasta, wheat flour, cereals, oats



Chelyabinsk, Russia

www.makfa.ru

MAIN DIRECTIONS

MAKFA pasta is brand #1 in Eastern Europe, it absorbs more sauce, have different shapes, multifunctional (energy/high calcium/with oats). MAKFA flour is brand #1 in Russia, has multiple purposes, it can be used in automatic breadmakers, as well as an additive to sauces, soup and deserts. MAKFA has International Certificates. All products are GMO free.

PRODUCTS

High calcium pasta, energy pasta, pasta with oats, wheat flour, italian pizza flour, pancake mix, grains and oats.

BENEFITS

- We use only selected grains raised on hearty Altai fields. We apply three-stages purification and sort the grains.
- First, we steam the whole grains to make them tender, flavorsome and easier to cook.
- Then we gently roll the oats using a modern technology to preserve all nutrients of every grain.

ITALIAN PIZZA FLOUR



GENERAL INFORMATION

- INGREDIENTS: PATENT WHEAT FLOUR FOR BAKING
- AIRTIGHT PAPER PACKAGE
- MADE IN RUSSIA
- GMO FREE
- SHELF LIFE 12 MONTHS

Description	Weight (kg)	Net weight (kg)	Product barcode	Transport barcode	Number of packages per pallet	Weight (kg)
Italian pizza FLOUR MAKFA, 1 kg	1.000	0.980	4801860000000	4801860000000	40	392.000

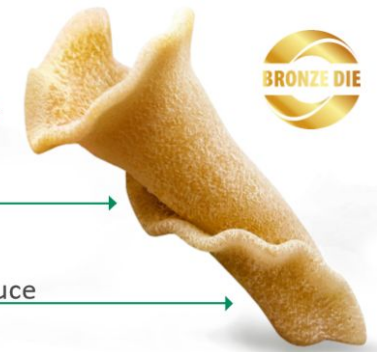

Protein 13 g

Porous structure

sauce





RUSSIAN
EXPORT CENTER



CHERKIZOVO

Meat production



Moscow

www.cherkizovo.com



MAIN DIRECTIONS

Meat and poultry production, RTC/RTH/B2B poultry and meat products.

PRODUCTS

Ground meat, meatballs, marinated ribs, whole chicken, frozen ground meat, fillet, salami and cured sausages, boiled sausages and hotdogs, marinated wings, seasoned sausages, cutlets, nuggets

BENEFITS

- Branded food company with #1 position in Russian meat sector
- Well balanced portfolio of chilled poultry and sausages brands
- One of the lowest cost producers in Russia
- Long term growth achieved through combination of organic expansion and strategic acquisitions
- Recently expanded state-of-the-art asset base
- Creation of new jobs in the regions of presence



TRAPEZA LTD MANAGEMENT COMPANY



Novosibirsk

www.trapeza.su

Trapeza products are known throughout Russia, near and far abroad, and are sold on the shelves of both “convenience stores” and in federal retail chains.

▶ MAIN DIRECTION

Novosibirsk Food Factory, specializing in packing and producing of food products

▶ PRODUCTS

classic spices , seasonings for various dishes, milkmaiders - ready-made solutions for the preparation of various dishes breadcrumbs for meat, fish, poultry culinary additives - citric acid, starch, vanillin jelly of various fruit and berry flavors, jelly mixtures for making sauces / gravies / marinades ice cream mixes

▶ BENEFITS

- seasonings without salt and without additives.
- high quality and natural
- food safety standards FSSC 22000, HACCP SGS GMP
- careful selection of raw materials Quality control
- technological control at all stages
- feedback





RUSSIAN
EXPORT CENTER



Yarovoe



artemia-arsal.com



ARSAL

Unique Producer of Artemia

▶ MAIN DIRECTIONS

Arsal - the oldest enterprise for the processing of Brine Shrimp eggs in Russia

▶ PRODUCTS

Brine Shrimp eggs are harvested only from the Great Yarovoye lake

▶ BENEFITS

- The production cycle is organized using advanced biotechnology
- More than 20 years of exporting experience
- Cooperation with global brands : INVE, CP, BERN AQUA, Artemia World S.R.O. etc
- Own scientific laboratory
- Stable quality and high nutritional value of the product
- Traceability of batches at each stages of processing: from harvest to shipment
- Technical support





RUSSIAN
EXPORT CENTER



Nizhny Novgorod

www.sordis.ru

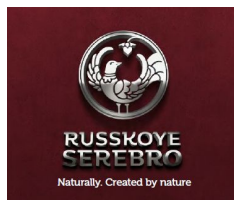

SORDIS LLC
Naturally. Created by Nature

▶ MAIN DIRECTIONS

Creation of tastes of alcohol beverages.

▶ PRODUCTS

Alcohol beverages: vodka, bitter, tinctures, brandy.

▶ BENEFITS

Strict adherence to unique technologies, quality control at each stage, high professionalism of the staff and the exceptionally natural composition of beverages are the main principles of our company. This is what allows us to produce really tasty drinks. That allows us to be proud of our work.

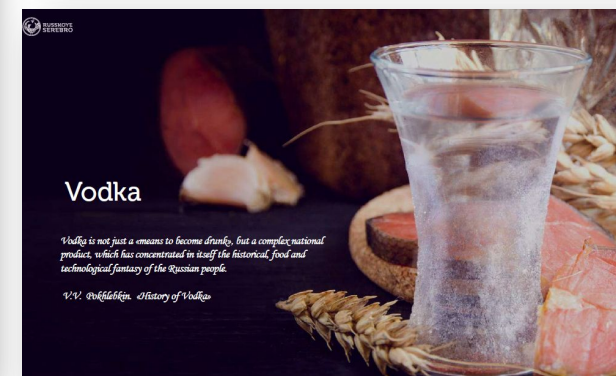
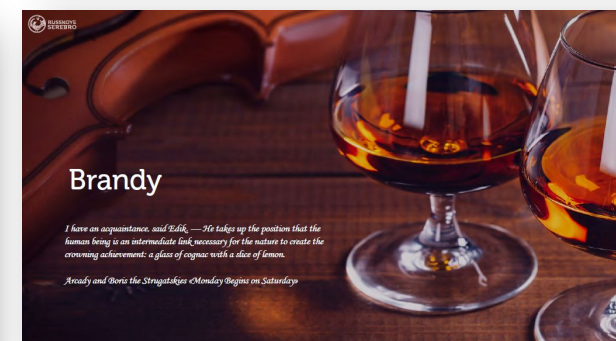
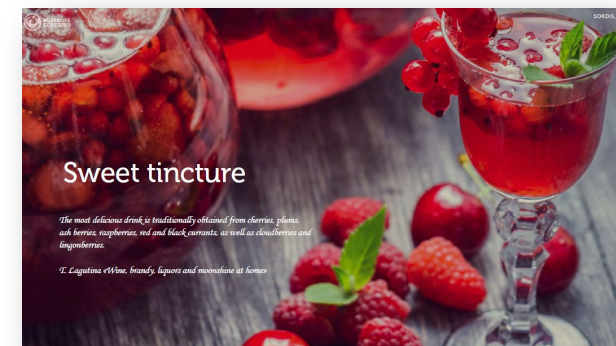



CONSUMER GOODS



RUSSIAN
EXPORT CENTER



The city of Ryazhsk,
Ryazan region

vestar.net



VESTAR LLC

Cosmetics and household chemicals

MAIN DIRECTIONS

Vestar is one of the leading Russian manufacturers, cosmetics, household chemicals and wet wipes. Company successfully cooperates with the largest distributors and retail chains in Russia.

PRODUCTS

Liquid detergents (washing gels, fabric softener, liquid soap, shampoo, bath foam, shower gel); production for children (baby wipes, liquid soap, shampoo); wet wipes (cosmetic, for household, for cars, antibacterial); supplies for complex cleaning of the house (supplies for cleaning plumbing fixtures, washing floors).

BENEFITS

We create products of a high quality in any segment: from economy to premium. The company is certified in accordance with ISO 9001 and ISO 14001. The production have won many awards and is highly valued by buyers.





SPRING

Natural remedies for beauty and health, our special amber series and many years of production experience - this is what we are ready to share with you!



Kaliningrad

springeco.ru

MAIN DIRECTIONS

Spring products are a chance to stand out from others, because we are not talking about adding a few extracts in cosmetics, but about all-natural gels, creams, masks, shampoos and other products.

PRODUCTS

A family recipe for cosmetics using succinic acid, amber powder and amber oil gives an amazing effect: it energizes, refreshes and fills with the necessary microelements. The power of amber will give you renewal, a sense of unity with nature and pleasure from the result.

BENEFITS

Five elements distinguish our products from other manufacturers - safety, high quality, natural composition, environmental friendliness and affordability. We believe that natural skin care should be available to everyone.

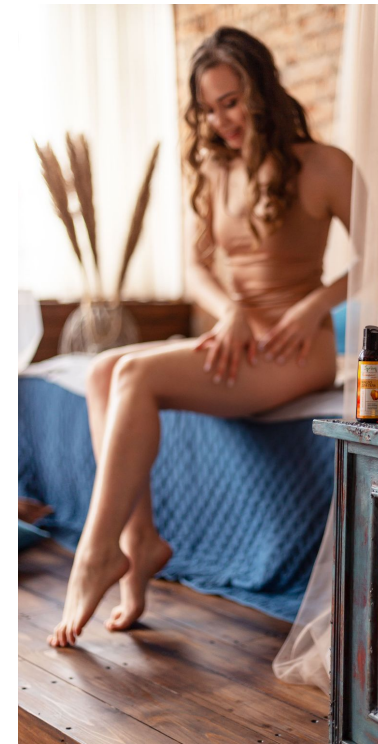
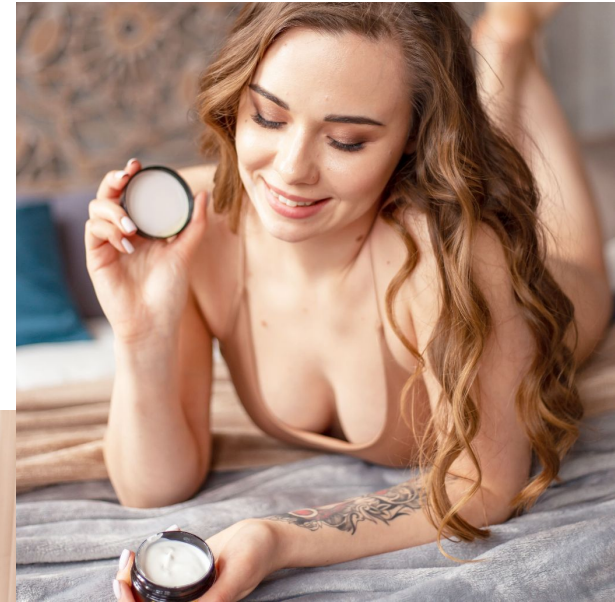



RUSSIAN
EXPORT CENTER

INTERNET
TECHNOLOGY
INDUSTRY



RUSSIAN
EXPORT CENTER



VIDGET LLC

EFFEBOT : new tool in marketing



Perm



effebot.com

THE ALGORITHM

<p>Step 1 Identify main business goal</p> <p>Step 3 Write a script for the solution</p>	<p>Step 2 Be sure to have database of clients</p> <p>Step 4 Made voice mailing</p>	<p>EXAMPLE SCRIPT</p> <p>Good afternoon, tomorrow at 10:00 you have an appointment with Dr. Slange. Will you come?</p> <p>No, I can't come tomorrow</p> <p>OK, do you still want to see a doctor?</p> <p>Yes, I do</p> <p>The next free appointment is on the 15th August at 2 p.m. Will you be able to come?</p> <p>Yes, I will</p> <p>Great, your appointment is rescheduled.</p>
---	--	--

WHY OUR CLIENTS CHOOSE EFFEBOT?

- Customers receive the message and you know that
- Higher delivery and conversion
- Personalised message
- You pay only for effective calls, per seconds



MAIN DIRECTIONS

SaaS service Zvonobot is a smart robot that is able to have a live dialogue with the interlocutor and shoots from 40% of call center activities on incoming and outgoing calls. We help companies make cheaper and faster calls, without losing clients and their loyalty.

PRODUCTS

We'll ring up all your customers in a few minutes. We conduct surveys with the processing answers and present/provide the finished result. Inform all clients about promotions, sales and news. Inform about delivery status profitably via voice mailing.

BENEFITS

At the moment, the speed of the service is 300,000 calls per hour, moderation is less than 1 minute, the presence of its own speech recognition and generation engine. The service has the ability to integrate into a CRM system, send SMS messages, and transfer complex calls to an operator.

WHAT DOES EFFEBOT DO?

Cold calls	Phone surveys	Informing customers	Fast and easy notifications
We'll ring up all your customers in a few minutes.	We conduct surveys with the processing answers and present/provide the finished result.	Inform all clients about promotions, sales and news.	Inform about delivery status profitably via voice mailing.

EFFEBOT IS

more than

300 000 calls per hour

4 500 active customers all over the world	7 presented in 7 countries	10 mln of successful calls per month
---	--------------------------------------	--



RUSSIAN EXPORT CENTER



Vologodskaya area

mallenom.ru



MALLENOM SYSTEMS LLC

Intelligent control systems based on machine vision and artificial intelligence (i.e. machine learning, deep learning natural network)

MAIN DIRECTIONS

Mallenom Systems in Russia and the CIS is the only official integrator partner of Cognex - the world leader in industrial vision systems.

PRODUCTS

The company has extensive experience in the successful implementation of high-tech IT projects in the field of transport, mechanical engineering, oil and gas, metallurgical, food, pharmaceutical, diamond mining, nuclear industries and other industries.

BENEFITS

The systems developed by the company are based on both proprietary solutions based on neural networks and deterministic algorithms for image analysis, as well as and algorithms from the world leader in machine vision, Cognex.

Ares of expertise

- Video control and inventory of the automotive transport
- Identification and inventory of railcars and rail tank cars
- Industrial control based on machine vision
- Detection and tracking of people in the video image

Industrial control based on machine vision
Visual control at the production line

TYPES OF SOLUTIONS (INVOLVES PRE-DESIGNED WORK, SOFTWARE DEVELOPMENT, WARRANTY AND POST-WARRANTY SERVICES)

- Detection and counting of manufactured items
- Examination of the accuracy of assembled item
- Examination and identification of items based on the colour
- Identification of defects and presence of foreign matter
- Taking critical measurements of the item and overall tolerance check
- Reading of alphanumeric markings
- Reading of 1D and 2D codes from labels and items
- Examination of the item edge

Video control and inventory of automotive transport

- VEHICLE ACCESS CONTROL**
Automarsh is a system for access control and inventory of automotive transport based on automated recognition technology of the vehicle number plates. There are more than 2000 system implementations in Russia, CIS and European countries.
- VEHICLE WEIGHING AUTOMATION**
Automarshal.Weighbridge is a system for automation of vehicle weighing stations, designed to improve the efficiency, reliability and transparency of the vehicle weighing process. There are more than 50 system implementations at production facilities of various industries
- COUNTING OF VEHICLE TRAFFIC**
AVEDEX is a software for counting and classification of vehicles based on the their type. The software collects visual data either from traffic cameras or from pre-recorded video file

Logos: ROSNEFT, Severstal, Vnukovo, PRIME, SPIEF, Argosy, Severstal, P&G, AEROSA, MD

2000+ implemented systems

50+ partners

Logos: COGNEX, Teco, KAMAX, LINE, MITSUBISHI ELECTRIC, TENSOFT

80+ regular customers

Logos: Severstal, BOSCH, BASF, UK LUKOIL, CAZPROM, P&G, ITI, AEROSA, MD



RUSSIAN
EXPORT CENTER



MODERN
FOUNDRY
TECHNOLOGIES

SLT MODERN FOUNDRY TECHNOLOGIES

is the number one engineering company in Russia
that provides the entire technological cycle



Moscow



www.en.sltgroup.ru/.ru

MAIN DIRECTIONS

end-to-end engineering of production processes

PRODUCTS

smart foundry – industry-specific MES system;
creating a new foundry production or upgrading an existing one

BENEFITS

- Consulting and marketing
- Complex engineering of production
- Supply, installation and launch of equipment
- Employee training, maintenance, repair and modernization of equipment
- Foundry automation, management and planning systems

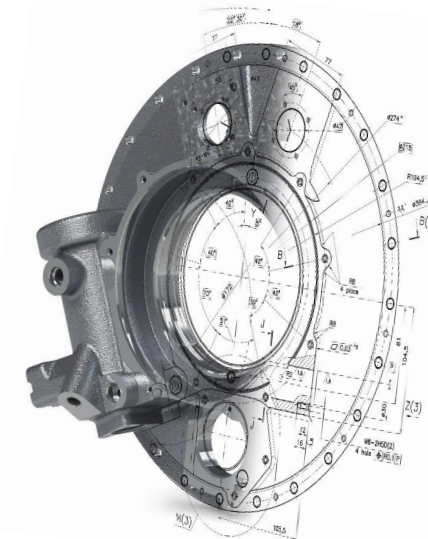
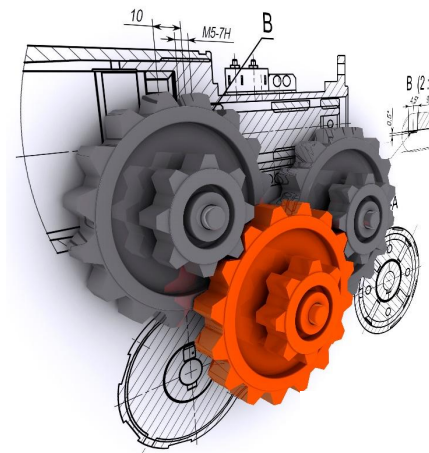



RUSSIAN
EXPORT CENTER



UFANET GROUP



Ufa



www.igidaworld.com

Ufanet Group is among top telecommunication companies in Russia, has extensive experience in telecom design and construction (more than 180 completed projects).

MAIN DIRECTIONS

own production of products for the construction of telecom networks and performance of construction and installation works

PRODUCTS

FTTH optical patch cords, cable ducts, software and hardware complexes «Smart Intercom» and «Smart House», system integration services, telecom design and construction services, TV channels and VOD- content for OTT platforms

BENEFITS

- performance of construction and installation works according to individual customer projects
- Production compliances with international standards, Lean Production concept.
- Experience in construction PON networks since 2016, own construction and sales technology «A-B-C-D-E».

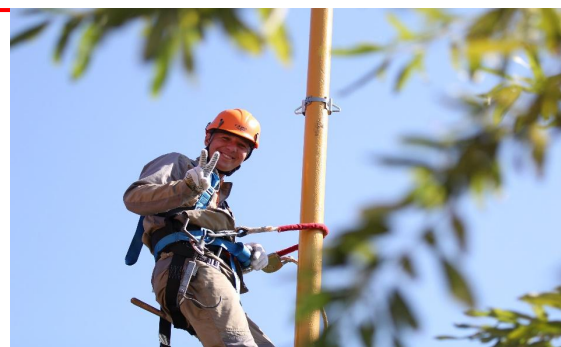

Divisus

Security systems

DIVISUS

Supplier of Integrated Security
Solutions by STILSOFT



Stavropol

divisus.com

MAIN DIRECTIONS

We provide a wide range of solutions for Video Surveillance, Access control, Perimeter protection, UAV's, video-management systems, video analytical integrations and so on. Special attention we pay to autonomous systems, solar and/or wind energy powered, which don't require electricity and cable lines and can be used for protection of remote facilities of any kind

MAIN PRODUCTS SUPPLIED

- Integrated security system for critical infrastructures «SYNERGET»;
- Autonomous video and thermal imaging surveillance system «AVANPOST» for State Border control;
- Autonomous fast-deployment video and thermal imaging surveillance system «MUROM»;
- Off-road vehicle based video and thermal imaging surveillance system «SCORPIO»
- Mobile perimeter protection system «MONGOOSE»;
- Radio Location and Ranging Stations
- Wide range of perimeter protection sensors, including autonomous ones, for use in remote areas with no infrastructure;
- UAV systems

BENEFITS of WORKING WITH US

Hardware and Software of our own development (manufacturing in Stavropol) allows us to solve security tasks for any type of the facilities: airports, railway stations, industrial facilities, seaports, police stations, military facilities, warehouses (including weapon warehouses), prisons, banks, medical institutions and much more





INVENTIVE PRODUCTION CENTER



Republic of Tatarstan

ipc-bugulma.com

Oil and gas industry, housing and utilities, construction of residential and non-residential facilities, metro, airports-construction of infrastructure. B2B.

MAIN DIRECTIONS

Creation and implementation of industrial technologies for the production of steel pipes lined with polyethylene; bimetallic lining bushings to protect welded pipe joints from corrosion; all-in-one electrical insulating coupling connection; shaped pipeline parts with internal and external anticorrosive coatings; coupling connection technology, which allows you to connect pipes made of various materials, but primarily pipes protected from internal corrosion, without welding.

PRODUCTS

Electrical isolation joint NEMS is installed in supply nets of a gas service, on the cross-country pipelines, oil pipelines and water pipelines for the protection of corrosion, resulting under the influence of stray currents, and for the making electrical disconnection, that is protected by pipeline electrochemical protection.

BENEFITS

- The absence of fire works preserves the internal coating at the ends of the pipes
- High installation speed up to 7 minutes
- Does not require a highly qualified welder
- Reduces the cost of pipeline installation by welding by 5-10%
- Installation from -60 to +120 C in difficult climatic conditions
- No harmful substances are released into the environment

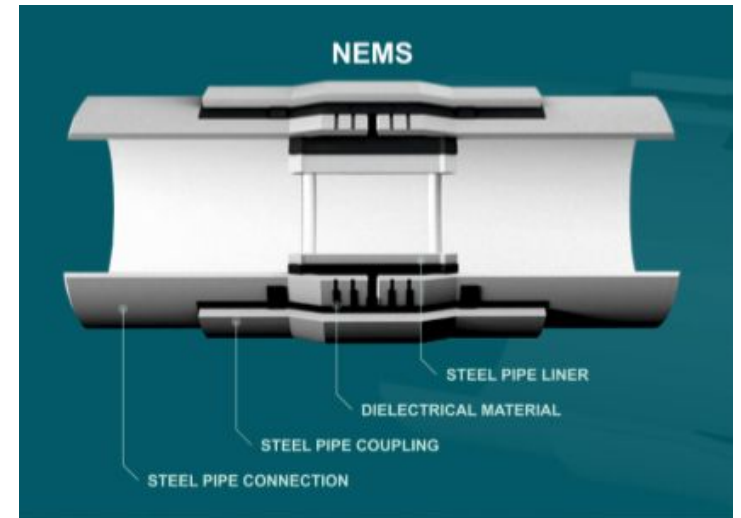



RUSSIAN
EXPORT CENTER



RITM OKB ZAO



Taganrog



scenar.com.ru

SCENAR - an abbreviation of the full name of a medical devices class. It is short for a self-controlled energyneuroadaptive regulator. Or, briefly, energyneurostimulator.

▶ MAIN DIRECTIONS

The physiological purpose of pain is to warn us about an injury or a pathological process. It draws body's attention to a necessity of taking some actions. Modern medicine can offer drugs and medications that can suppress pain perception. However, this results in the loss of the physiological meaning of pain and contradicts the biological mechanism.

▶ PRODUCTS

SCENAR

▶ BENEFITS

The main advantage of SCENAR is that its impulse is bio-variable. Responding to the skin reaction, it automatically "adjusts" the parameters for the most efficient treatment

- SCENAR impulse is physiological;
- SCENAR does not damage tissues, because it does not heat them, or make them do the unnatural "work";
- SCENAR combines the benefits of many methods of physiotherapy, such as darsonvalization, miostimulation, diadynamic currents and even ultrasound;
- SCENAR has minimum contraindications;
- SCENAR has a significant anti-pain effect

PRACTICING DOCTORS
CONFIRMED AND KEEP
PROVING THE EFFICIENCY

OF **SCENAR**
.....



hello.io INTERACTIVE TECHNOLOGIES



Moscow

Hello.io

Interactive digital park for entertainment and creativity

MAIN DIRECTIONS

Hello.IO — an international company that implements projects at the intersection of design, architecture and technology. We create immersive high-tech spaces, tell stories, and create a new culture of human-digital interaction.

One of our key technologies is phygital (physical + digital) — the integration of the physical and digital world.

PRODUCTS

Hello Park, Hello Computer, Hello Sport, Hello School

BENEFITS

The multimedia format is new, makes it possible for quick changes to the park's content which creates the incentive for repeat visits and allows for many visitors at the same time. All together this makes for a very attractive business opportunity.

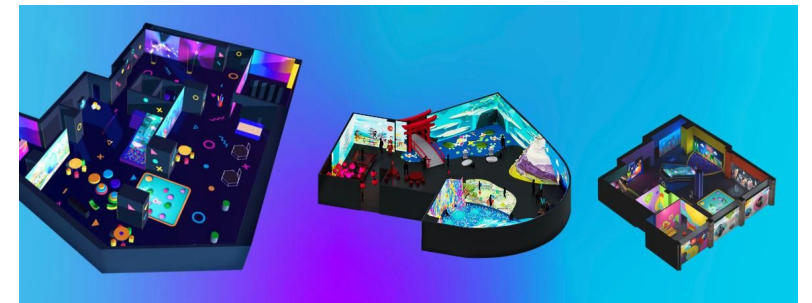
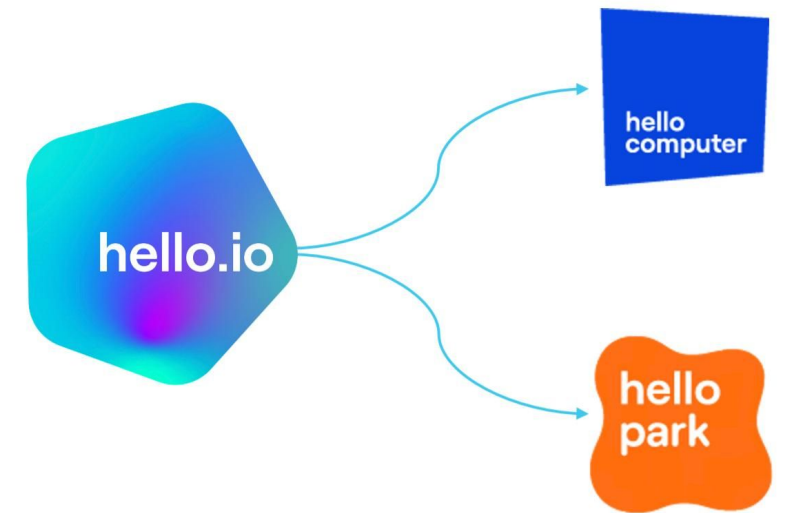



FARMA



RUSSIAN
EXPORT CENTER

MEGI®

MEGI LLC

Medical Enterprise Group Inc.

Furniture and equipment for medical organizations



Ufa



www.megi.company

MAIN DIRECTIONS

Development, research, manufacture of furniture and equipment for medical organizations, after-sale service.

PRODUCTS

UV air purifier, functional medical beds, GYN examination chairs, medical metal cabinets, cross-functional surgical tables, lab modular furniture and integrated equipment solutions.

BENEFITS

- Integrated equipment solutions;
- Certified quality;
- Tailor-made approach;
- Worldwide delivery.

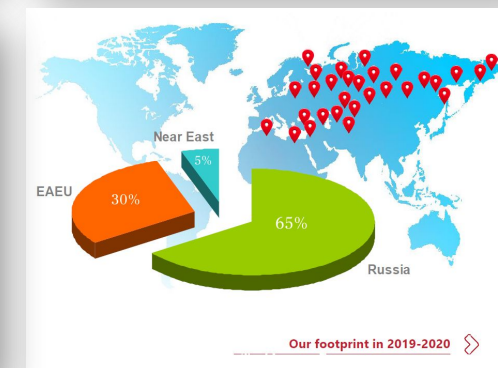
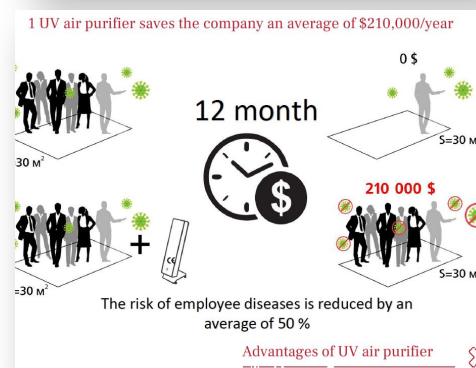
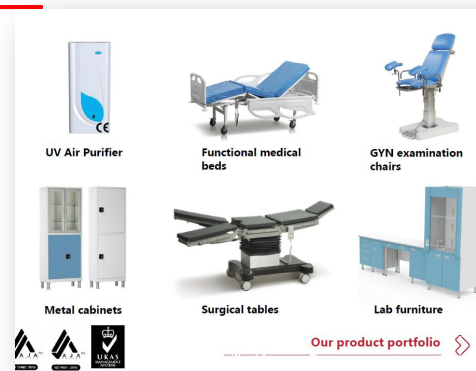



БАЙКАЛЬСКАЯ
ЛЕГЕНДА

SIBPRIBOR LLC

Products TM «BAIKAL
legend». To live longer



Irkutsk area

www.baikal-legend.ru

MAIN DIRECTIONS

Scientific developments in the field of creating a special technology for obtaining natural extracts, making very natural and unique production.

PRODUCTS

BioChaga and BioDihydroquercetin.

BENEFITS

Biochaga and BioDihydroquercetin are obtained from ecologically pure raw materials of the Baikal region; The natural raw materials collected in Siberia contain the maximum amount of biologically active substances due to the sharply continental climate of our region; The unique technology (low temperatures and deep vacuum) allows to extract biologically active components of natural raw materials as much and lossless as possible and preserve their natural form; Special - super light - the consistency of product (micro-dimension of the particles), ensures their high bioavailability; In the production process, aggressive chemicals and high temperatures are not used; The final product is 100% active substance and does not contain preservatives, dyes and ballast substances.

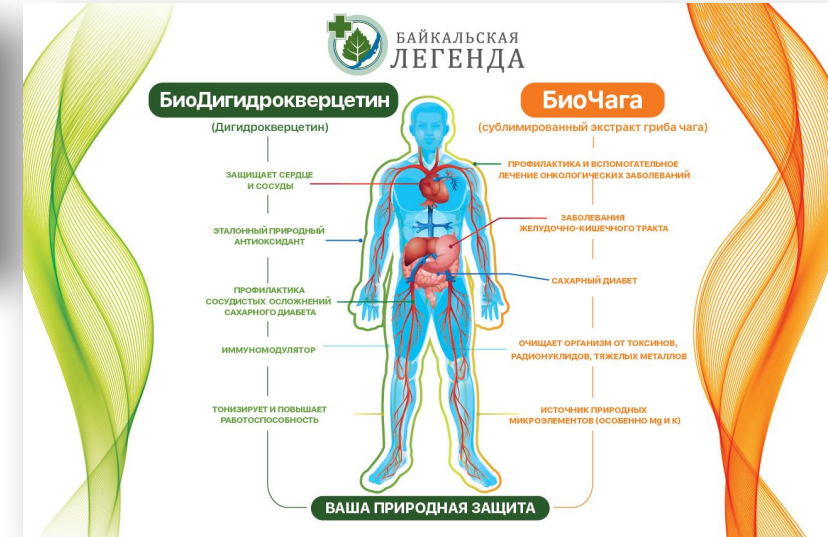



LLC "PARAPHARM"

Innovative enterprise for dietary supplements manufacturing. PARAPHARM LLC was founded in Penza (Russia) in 1995. The company produces dietary supplements and vitamin and mineral complexes from natural raw materials: medicinal herbs and bee products. It has its own fields for plants growing and production site for processing.



Penza

www.secret-dolgolet.ru

MAIN DIRECTIONS

Dietary supplements and vitamin and mineral complexes from natural raw materials: medicinal herbs and bee products.

PRODUCTS

PARAPHARM offers more than 100 natural products containing medicinal herbs cultivated in ecologically clean districts of Russia. These are vitamin and mineral complexes for cardio-vascular system health, male and female health, osteoprotectors, remedies for thyroid health and strong nerves, vitamin and mineral complexes for sportsmen and active people, tableted and packed medicinal herbs.

BENEFITS

- Patented unique organic components u compositions;
- Cryo processing technology which helps to preserve all useful features of plants and to increase efficiency of products;
- Every product is a unique complex of vitamins and microelements selected by Nature.





IMBIAN LABORATORY DIAGNOSTICS LLC

IMBIAN Group of Companies is a company-developer of innovative multiplex kits for early diagnosis of various diseases, developer of kits for enzyme-linked immunosorbent assay (ELISA tests) and distributor of a number of Russian and foreign manufacturers of test systems for medicine and veterinary medicine.



Novosibirsk region

www.imbian.ru

MAIN DIRECTIONS

Development of medical equipment for testing

PRODUCTS

For medicine: ELISA test systems, PCR test systems, CLIA test systems, Immunochip test systems for medicine

BENEFITS

- Systems (ELISA, PCR, RMP, etc.) for medicine and veterinary medicine
- Distributor of a number of Russian and foreign manufacturers
- Implements its innovative product — production of multiplex test systems based on protein matrices (immunochips)



RT-PCR



ELISA IgG IgM



LFIA Ab



LFIA Ag

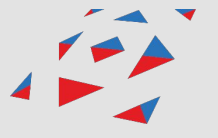

METALLURGICAL INDUSTRY



RUSSIAN
EXPORT CENTER



MOTOVILIKHA CIVIL ENGINEERING COMPANY, LTD.

Oilfield and drilling equipment



Perm

www.mzperm.ru

MAIN DIRECTIONS

Complete production cycle: from steel making to release or finished products.

PRODUCTS

Metallurgical products and oilfield and drilling equipment.

BENEFITS

- The plant works over 25 years.
- The product is licensed and meet global standards.
- We use high-quality raw materials.

METALLURGICAL PRODUCTS

FORGINGS
CLOSED DIE FORGINGS
LONG PRODUCTS
CASTINGS

OILFIELD AND DRILLING EQUIPMENT

SUCKER RODS
DRILL COLLARS, HWDP AND KELLYS
SUBS AND CONNECTIONS

**COMPLETE PRODUCTION CYCLE:
FROM STEEL MAKING
TO RELEASE OF FINISHED PRODUCTS**

DRILLING EQUIPMENT

BDC – balanced drill collar

Intended for axial loading of the drilling bit and increasing axial string stiffness. BDC with spiral grooves are used for drilling of deep wells in order to mitigate the possibility of tool sticking caused by reduction of the area of contact between the drilling collar string contact with the well walls.

Technical Specification	
Regulatory documents	TS 3 RS 200-2003, API Spec 7.1
Length, mm	4 500... 9 600

Types of BDC

- A – smooth, without recess
- B – slip and elevator recess
- D – elevator recess
- C – slip and elevator recess, spiral grooves
- CM – slip recess and spiral grooves
- DC – slip recess and spiral grooves
- Z – hard faces
- BT – inner polymer coating

DRILL COLLARS MANUFACTURING UPGRADE

Thread cutting machine tool commissioned.

OIL PRODUCTION EQUIPMENT

SUCKER RODS WITH SCRAPERS AND CENTRALIZERS

For oil production using sucker-rod plunger and screw pumps.

Advantages of equipping sucker rods with centralizers and scrapers:

- Protection of tubing, sucker rods and sucker-rod couplings from excessive wear.
- Cleaning of sucker rods and tubing from asphalt-resin-paraffin deposits.
- Centering of sucker rods in a well.

Technical Specification of Centralizers	
Regulatory documents	TS 3665-020-48416997-2003
Design options	– Fixed centering scrapers – Floating scrapers – Centralizers for screw pumps – Inter-coupling centralizers for screw pumps
Material	High-strength polyamide-reinforced glass
Stability to corrosion	Any reservoir conditions, including hydrogen sulfide environments, with temperature up to +110 °C
Friction coefficients:	– Static 0.10 – Dynamic 0.11
Setting shear strength, t	2... 2.2
Scraper compression strength	8.8... 12.7

CONNECTION AND ADAPTER COUPLINGS

Intended for connection of sucker rods between one another.

Technical Specification	
Regulatory documents	TS 3665-020-48416997-2003
Outer diameter, mm	– Full-size 60.3, 55.4, 50.8, 46.4, 41.3, 36.1 – Small diameter 35.8, 41.3, 36.1, 31.8
Outer surface wear-proof coating	– Heat-treated, no coating – 1 – Hardened with high-frequency currents – 5
Steel grades	Structural and alloyed steels
Adapter couplings	16x15, 19x22, 22x25, 29x29

OIL PRODUCTION EQUIPMENT

OVER 60 YEARS OF SUCKER ROD MANUFACTURING

SUCKER RODS

Intended for transmission of movement from surface drive to borehole plunger or screw pumps.

ADVANTAGES:

- The product is API-licensed and meets global standards
- The manufacturing process is fully automated (equipment of leading global producer is used: SURFACE COMBUSTION furnaces, ETCHING lines, ST2) and OKUMA processing centers), ensuring consistent quality of the finished products.
- Use of own long products manufactured from high-quality steel grades with superior performance characteristics enables the full cycle of sucker rod production.
- Advanced strength and anti-corrosion properties.
- Sucker rods can be optionally equipped with centering scrapers.
- Urgent orders are accepted, delivery timing is stable.
- The products are recognized at the oil producing sites of the CIS countries and beyond, including such loyal customers of the company as PUSC, TATNEFT, PUSC, LUKOIL, PUSC, M&P, ROCHEFT.

Technical Specification	
Regulatory documents	TS 3665-020-48416997-2003, 118 API
Specific diameter of rod, mm (inches)	38 (1.5), 19 (0.75), 22 (0.875), 25 (1)
Strength class	K, C, D – Due to strength properties 1.4 times higher than D category. – Due to selection in the most demanding conditions, there high fatigue strength in corrosive environment. – Fatigue strength – heat treatment with further processing with a shot blasting unit.
Length, mm	at 600 up to 9 340
Steel grades	4307MA, 15021MA and other high quality alloyed steels, 100 % blanks undergo ultrasonic incoming examination.

Delivery options:

- Heavy weight sucker rod applicable in forming a "heavy bottom" and improving rod string stability in curved wells and high viscosity wells.
- Sucker rods manufactured of high-alloy, corrosion resistant rod products.
- Sucker rods with centralizers.

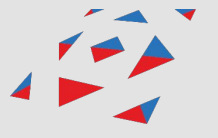

CHEMICAL INDUSTRY



RUSSIAN
EXPORT CENTER



CHEMCENTRE

**Scientific and Production Association CHEMCENTRE
– is one of the biggest manufacturer of fire-proof
fabric and materials in Russia.**



Novosibirskiy region,
Ozerniy
chemcentre.ru

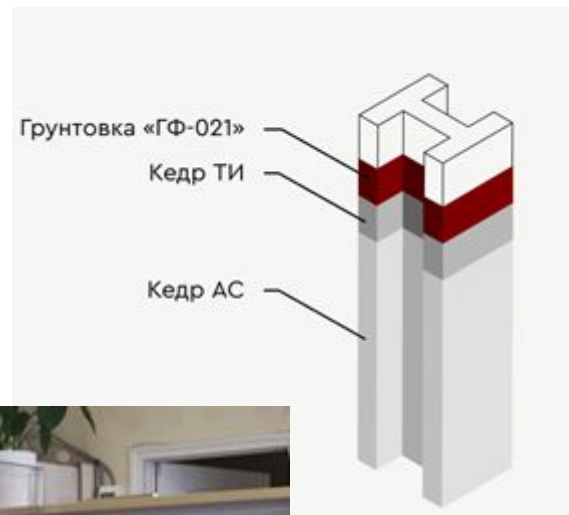

MAIN DIRECTIONS

Producing over 20 different types of fire proof materials, unique chemical synthesis operations of intermediate products, powerful production line, export to Europe and CIS.

PRODUCTS

Fire retardant coverages, fire proof fabric, flame-retardant thermal expansion coating for metal on an oranic basis, flame-retardant, thermally expanding coating for metal based on hydrogen dispersion. weather-resistant thin-layer flame retardant coating for metal on an organic basis

BENEFITS

SPA Chemcenter have their own multifunctional Research and Expiremental laboratory, two research groups, which allows to find new solutions and improve the quality of materials used in current manufacture.



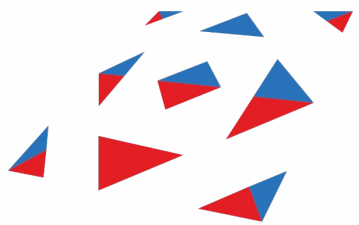

**RUSSIAN
EXPORT CENTER**

123610, Москва, Краснопресненская наб., 12

www.exportcenter.ru