

# Children's furniture, Toys from environmentally friendly wood



**Company GreenWay LTD, s.r.o. represents**

**New series of toys**

**"Wood Designer" TM ArInWood**

**For children from 6 years old.**

**Kits contain many different types**

**Wood parts are also available in sets.**

**construction tools and instructions added.**

**Constructor Build Method**

**consists in beating constructive**

**special cylindrical elements**

**elements with a hammer.**

**After assembling the toy, you can Use as a model and a complete toy.**



# Designer of wood PLANE

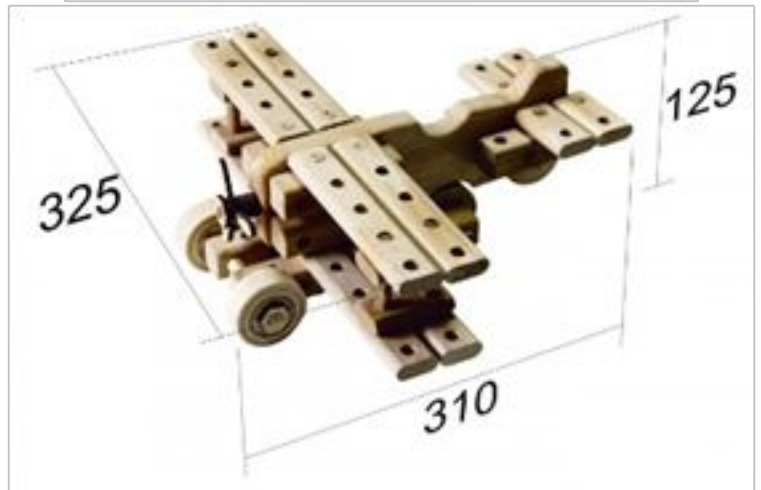
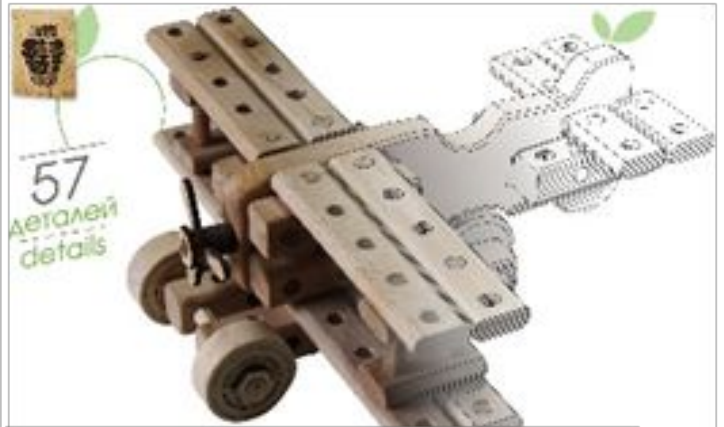

1. Overall dimensions of the package, mm  
 $234 * 290 * 72$

2. The number of elements is 70 pieces.

3. The weight of the product is 2.5 kg.

4. The price of

# Designer of wood GELIKOPTER



1. Overall dimensions of the package, mm  
 $234 * 290 * 72$

2. The number of elements 57 pcs.

3. Product weight,  
2.5 kg.

4. Price of

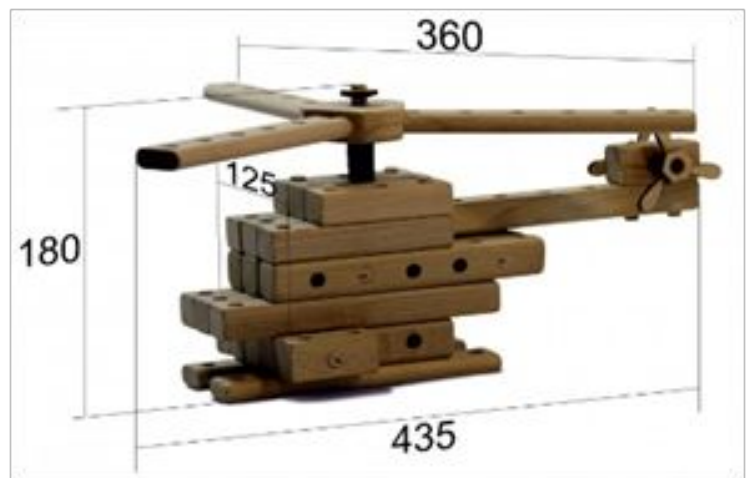



# Designer of wood TRACTOR

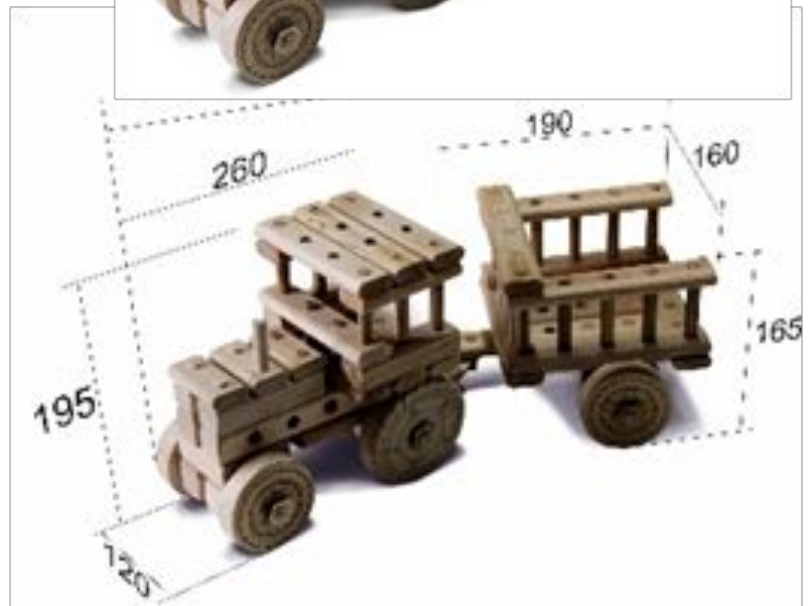
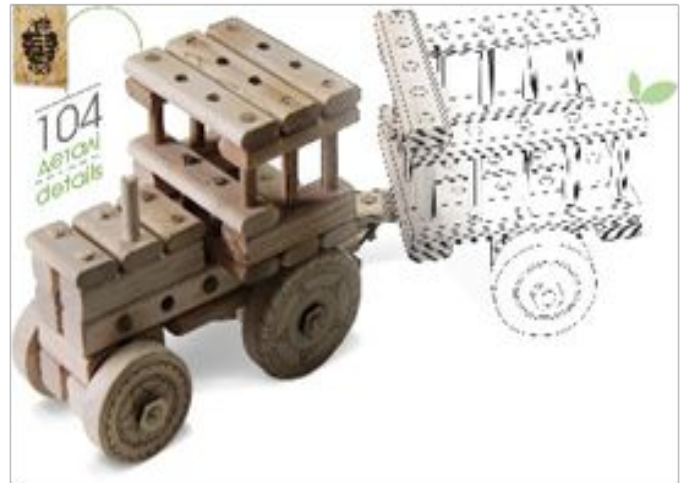

1. Overall dimensions of the package, mm  
 $234 * 414 * 72$
2. The number of elements is 104 pieces.
3. Product weight, 3.2 kg.
4. Price,

# Wooden constructor TRUCK



1. Overall dimensions of the package, mm 234 \* 414 \* 72

2. The number of elements is 70 pieces.

3. The weight of the product is 3.2 kg.

4. The price of

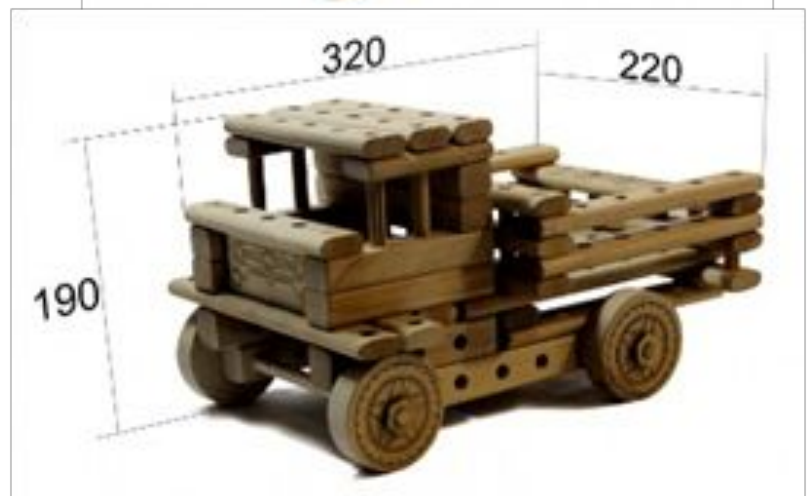

# Eco-cubes "Little Builder"



"The set of cubes contains about 70 parts of different sizes and shapes.

This will allow the child to build many shapes and the size of the buildings every time getting a new toy. «

1. Overall dimensions of the package, mm 720 \* 270 \* 440
2. The number of elements is 70 pieces.
3. The weight of the product is 1,7 kg.
4. The price of





# Crib for doll No. 1



1. Overall dimensions of the package, mm 720 \* 270 \* 440
2. Number of items 1 pc.
3. Product weight 3 kg.
4. The price of





# Set of table and two chairs

**Set of table and two chairs  
for a doll measuring 25  
cm.**

**Durable toy made  
solid wood beech.**

**Surface of toys  
decorated  
art laser engraving.**

1. Overall dimensions of  
the package, mm 380 \*  
560 \* 470

2. Number of items 12  
pcs.

3. The weight of the  
product is 1.5 kg.

4. The price is



# School desk children's "Owlet"

"Children's desk Owlet -  
Designed for children from 3 to  
10 years.

Made from durable eco  
friendly

pure wood compliance  
highest safety standards.

Easy to fold; is regulated  
seat and countertop height;  
tabletop angle is adjustable  
for the convenience of the  
child's activities and

development

correct posture;

comfortable and roomy drawer

for notebooks,

albums and pencils;

laser application of German

and

english alphabet



1. Overall dimensions of the package, mm 700 \* 180 \* 540
2. Number of items 1 pc.
3. The weight of the product is 14 kg.
4. The price of

# Children's stools

"Seat height - 26 cm.  
Seat size - 23x30 cm.  
The height of the stool is 52 cm.

Stool for children BEAR  
performed in compliance  
with existing  
ergonomic requirements.

For coating used  
acrylic non-toxic paints  
and natural oils and waxes

Due to its design  
and non-toxicity  
recommended  
for use

in kindergartens and  
nurseries, as well as  
at home. Packed  
unassembled. "

1. Number of items 2  
pcs.

2. The weight of the  
product is 2.5 kg.

3. The price is



## VUDIK chair

"Seat height - 26 cm.  
The size of the seat is  
25x34 cm.  
The height of the stool is  
54 cm.  
High chair for children  
VUDFK  
performed in compliance  
with existing  
ergonomic requirements.  
Natural wax is used for  
coating.  
Products disassembled  
viglyadi.  
Packaging - corrugated  
cardboard size  
575x290x50 mm. "





# Wooden products for children with natural environmentally friendly pure wood - Beech, oak, Plum, Apple tree, Pear.

