



厦门福朗德智能装备有限公司
Frاند intelligent equipment co., LTD

公司介绍
Company introduction



目录

公司介绍
Company profile

01

研发设计
Research and development

02

产品体系
Product system

03

服务体系
Service system

04

竞争优势
Competitive advantage

05





公司简介

Company profile

Xiamen Frand Intelligent Equipment Co., LTD. specialize in industrial automation intelligent equipment manufacture, sales and service of international trade business, the company service object for global manufacturing enterprises, the business scope includes CCD visual system research and development, automation equipment to provide professional system production line sales, automation upgrade solution, etc. The company founded in 2012, is a collection of R&D, manufacturing, sales, service, technical training and talent customization for the integration of industrial automation equipment manufacturer and service providers, the company's business scope includes: industrial robot automation equipment production, research echnol





公司简介

Company profile

The development course 发展历程

- 2008-2011 Set up joint venture company
Xiamen Jin-ao Automation Technology Co. LTD
- 2012 Set up Xiamen Frand Intelligent Equipment Co., LTD
- 2013 The company has developed into normal orbit
- 2015 The turnover reached 20,000,000 RMB
- 2017 The turnover reached 30,000,000 RMB



公司简介

Company profile

Turn over (ten thousand RMB) 销售额

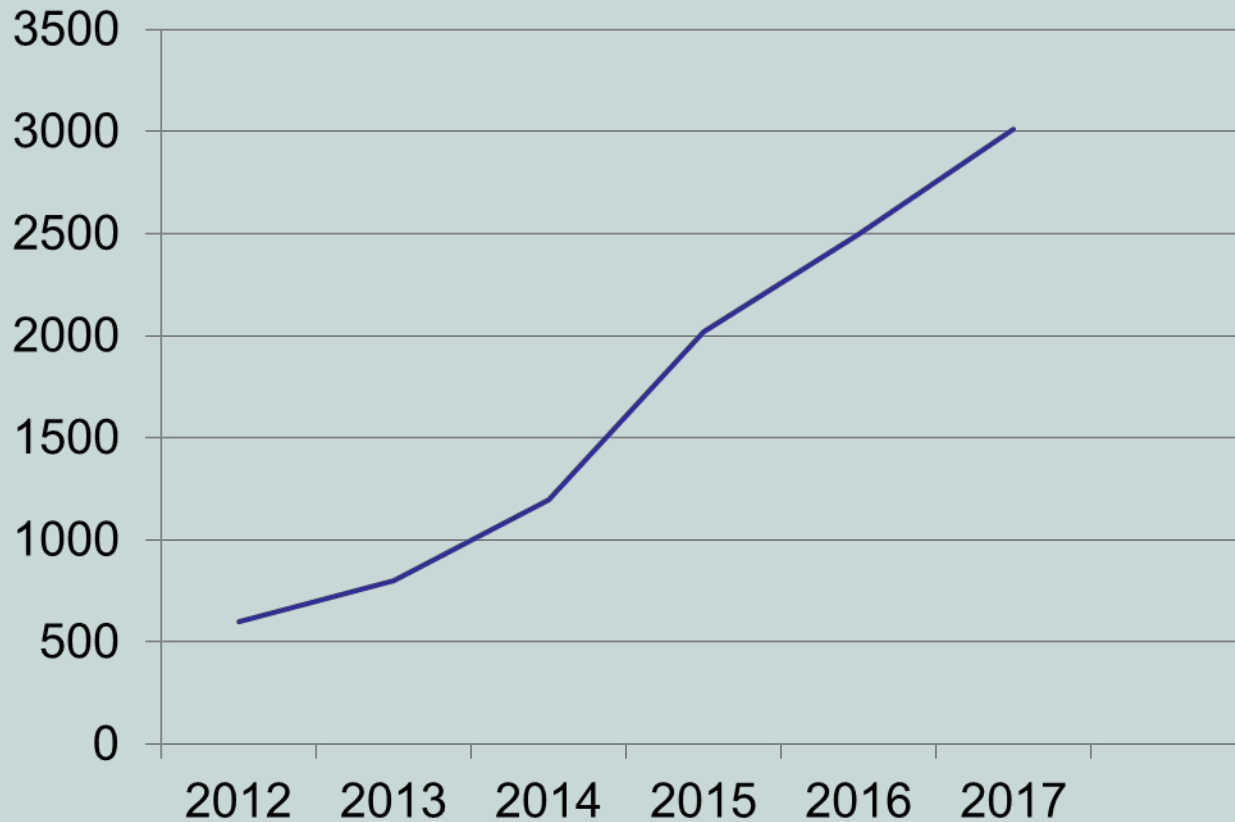



部分行业应用客户

Part of the industry application of customer

Schneider
Electric

DELIXI

Spectrum Brands | 品谱

HF·宏发股份

三友继电器
SANYOU RELAYS

DFE
东方电子集团有限公司

美的 Midea

CHIGO 志高空调

Galanz 格兰仕

振华集团
ZHENHUA GROUP

CHNT 正泰电器

TENGEN 天正电气

KINGSTATE

华工高理

DELTA 台达
中达电通股份有限公司

BYD
Build Your Dream
比亚迪



SHUANGLIN 双林

ABB



中国·人民电器集团
PEOPLE ELE. APPLIANCE GROUP CHINA



OIR BAGLA



海外市场

The overseas market



The equipment has been exported to India, Peru and other countries. In the future, it will cover Europe, America and Asia.



目录

公司介绍
Company profile

01

自主研发
Research and development

02

产品体系
Product system

03

服务体系
Service system

04

竞争优势
Competitive advantage

05





研发实力

Research and development

- Experienced R&D team in China and pays great attention to talent training and reserve.
- More than 30 employees, including more than 20 professional technicians
- Hired professors as technical consultants.

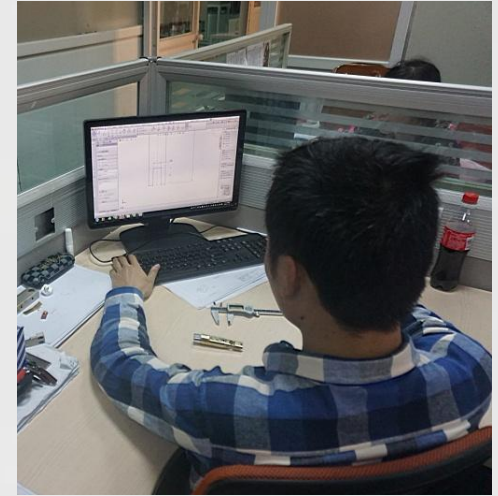





目录

公司介绍
Company profile

01

自主研发
Research and development

02

产品体系
Product system

03

服务体系
Service system

04

竞争优势
Competitive advantage

05





产品体系

Product system

S.N.	Automatic intelligent equipment 自动化智能设备
1	Industrial robot and multi-function robot hand
2	Automatic assembly line (equipment) for electronic industry
3	Automatic assembly production line (equipment) for low-voltage electric appliance industry
4	Automatic assembly production line (equipment) for automobile and auto parts industry
5	Automatic assembly production line (equipment) in sanitary ware industry
6	Loudspeaker, alarm and other electronic sound industry automatic assembly line
7	Automobile valve core assembly automatic production line
8	Commodity class surrounding the injection molding industry automation production line
9	Auto hoops automatic assembly line
10	Buzzer automatic wire welding equipment



**The application of
FRAND equipment
to customer
production lines**





汽车摩托车化油器生产线

Automobile motorcycle carburetor production line



汽车、摩托车化油器组装生产线

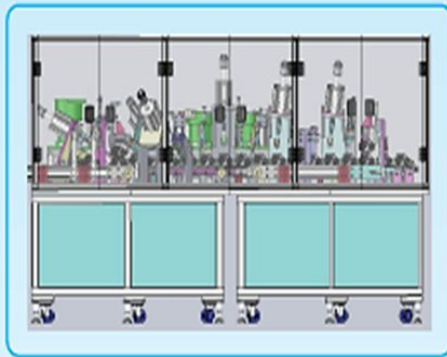

化油器生产线由10-15台组
装单元组成，自动完成各零件
装配、解压、检测和分类等。

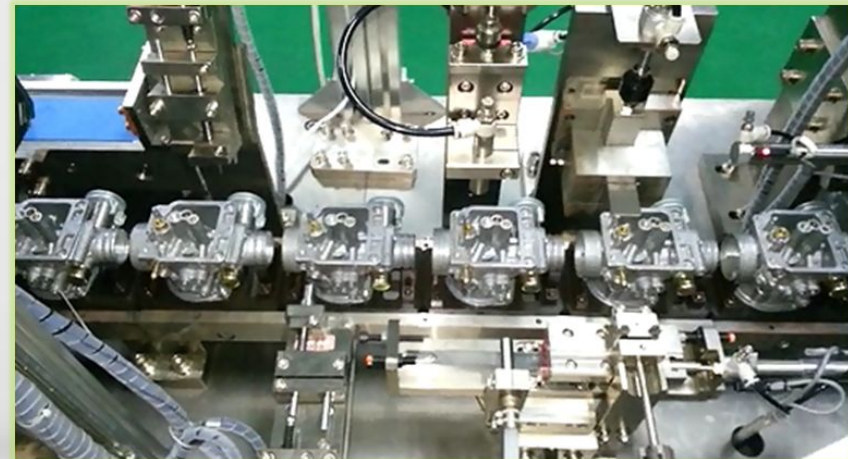
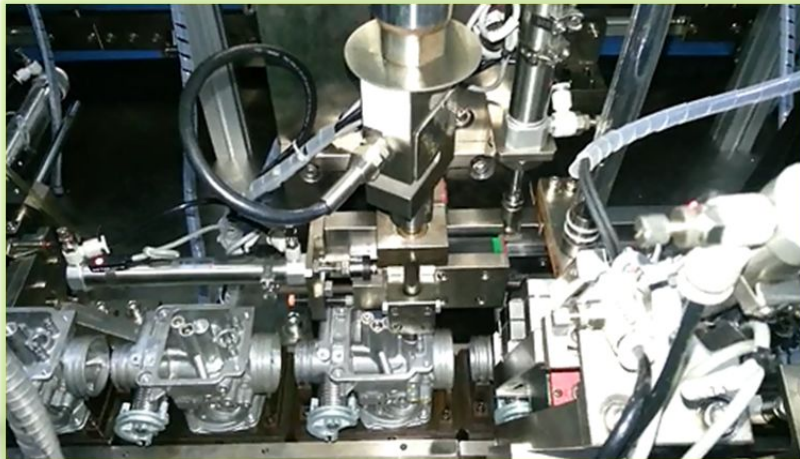
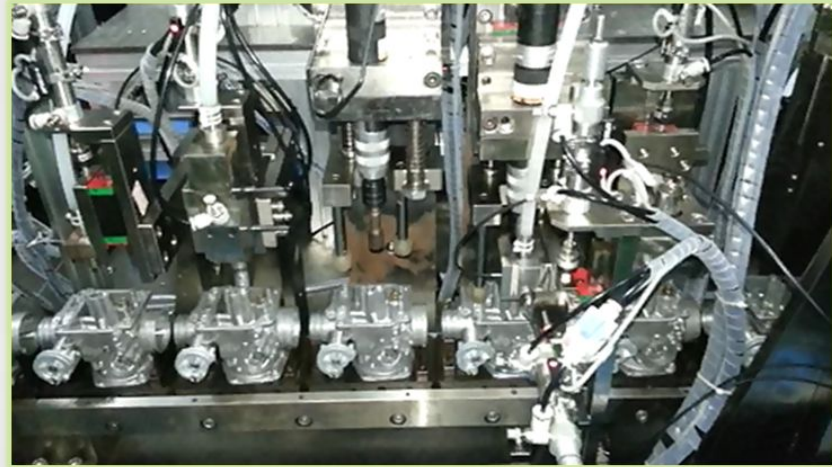



汽车气门芯自动装配线 Auto valve core automatic assembly line

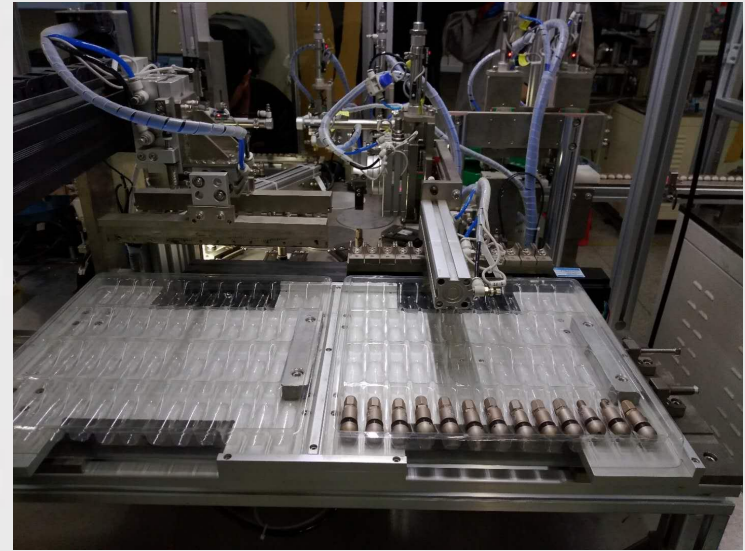



喉箍自动装配汽车 The automatic assembly line clamp





弯嘴气门芯装配机

Bent mouth valve core assembly machine

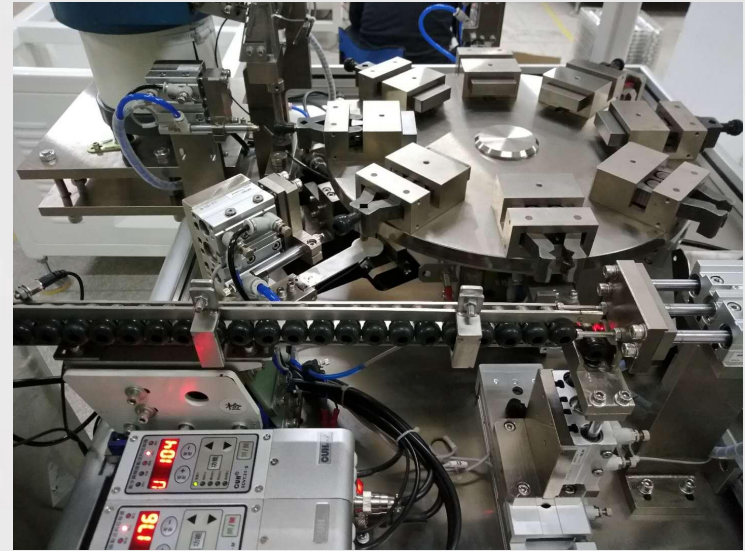



塑料夹子自动装配机

Automatic assembly machine for plastic clips

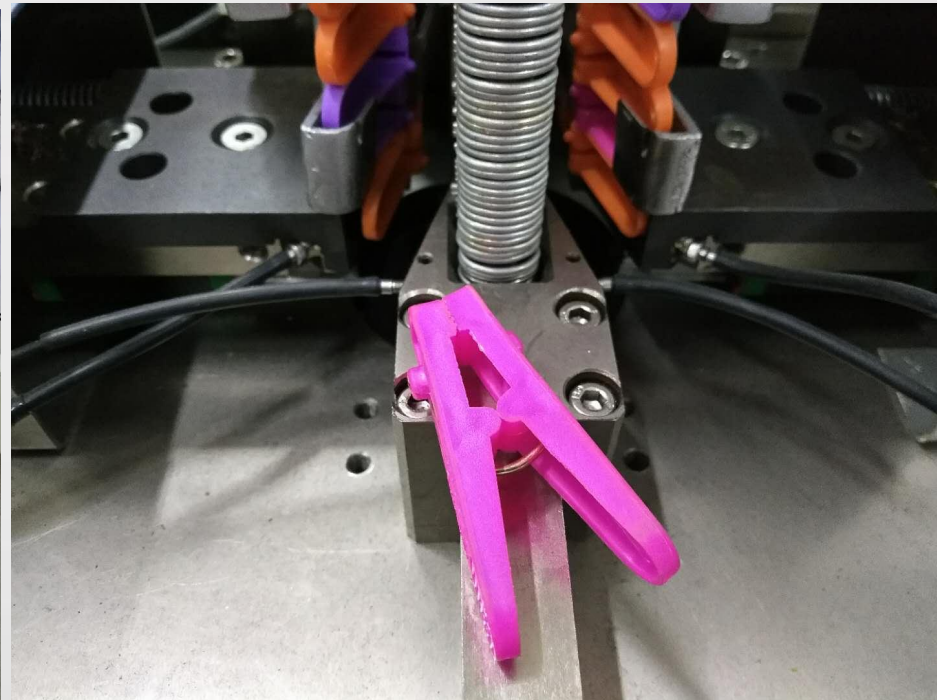



蜂鸣片焊线专机

Buzzer plate welding line special machine

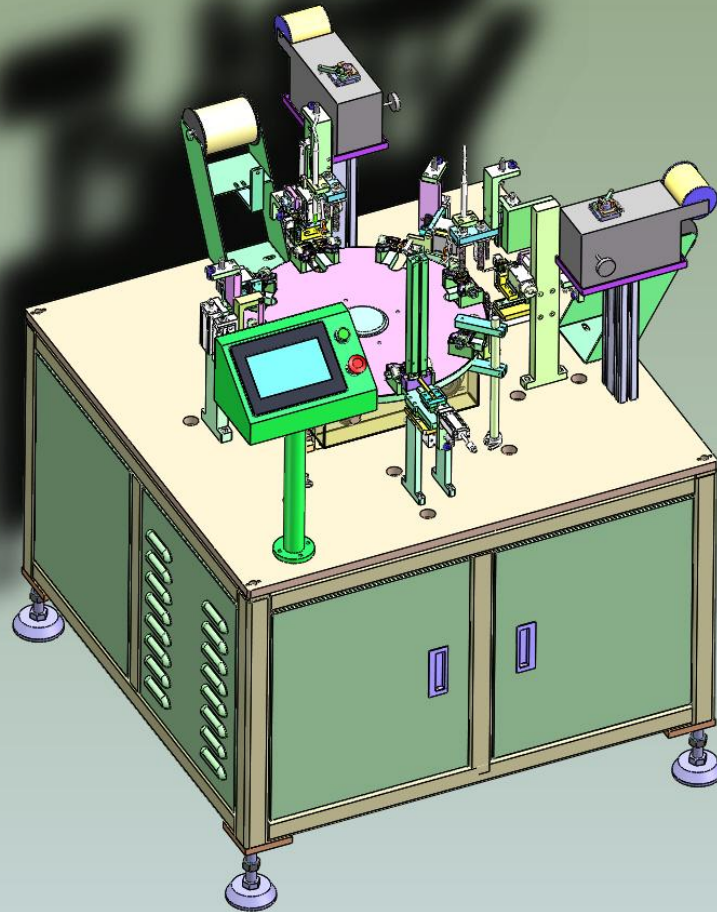



汽车摩托车化油器生产线

Automobile motorcycle carburetor production line



汽车、摩托车化油器组装生产线

AUTOMOBILE MOTORCYCLE CARBURETOR ASSEMBLY LINE

产品优势:

随行工装、准确定位
高度检测, 稳定可靠
国内首创、专利产品

合作客户:

福建友力化油器公司
华益机车部件厂等



接触器触桥支持装配机

Contactor contact bridge support assembly machine



接触器触桥支持装配机

CONTACTOR CONTACT BRIDGE SUPPORT ASSEMBLY MACHINE

产品优势:

全程自动、高效装配
质量稳定、节省成本
专利产品，仿冒必究

合作客户:

CHNT 正泰电器

TENGEN 天正电气

DELIXI



接触器触桥组装生产线

Touch the bridge assembly line contactor

专利产品 仿冒必究

装配二组
Assemble two groups

接触器装配线

接触器组装生产线
CONTACTOR ASSEMBLY LINES

应用客户: TENGGEN 天正电气
CHINT 正泰电器

服务专线: 13328766357

组装流程:



自动触桥插芯 → 人工上铁芯+上壳体 → 自动插入静触片 → 人工装弹簧
自动锁瓦片螺丝 ← 自动锁黑螺丝 ← 上下壳体组合 ← 人工装线圈+下壳体



汽车继电器生产线

Automobile relay production line

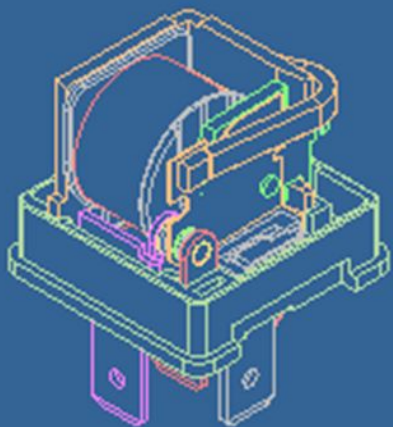
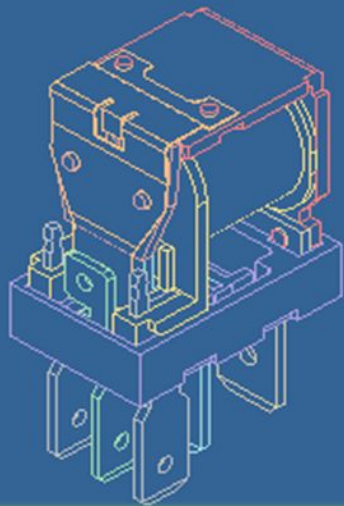

全自动汽车继电器装配生产线实现无人化操作，产品直通率达99%。



继电器综合全自动测试机

Relay integrated automatic testing machine

继电器综合全自动测试机

RELAY INTEGRATED AUTOMATIC TESTING MACHINE

适用范围

- 继电器塑封胶前的综合参数检测

主要功能

- 进行塑封后继电器综合参数检测

检测项目与范围:

- 动作电压、释放电压
- 线圈电阻、接触电阻
- 每一次检测5只继电器
- 产能: 3600只/小时。

Relay automatic testing machine

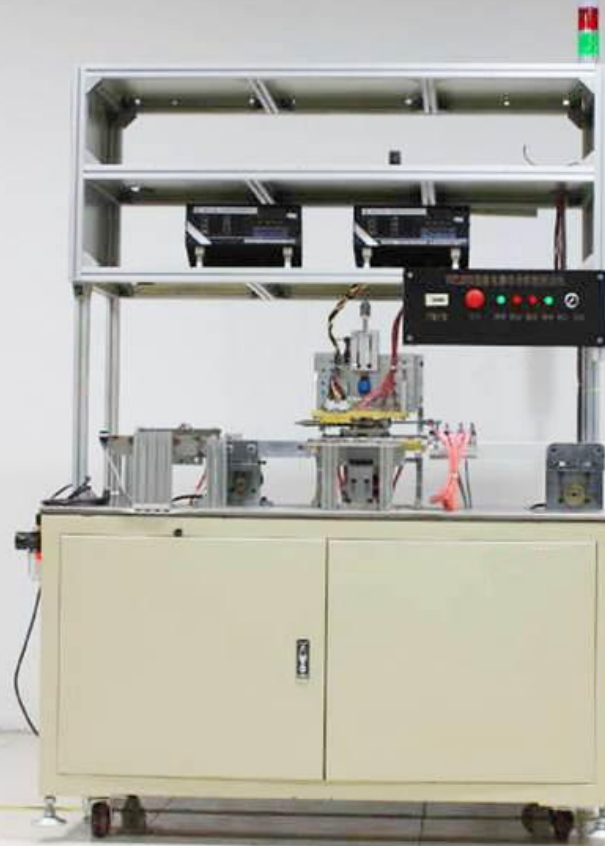



扭簧自动组装机

Torsional spring group installed automatically

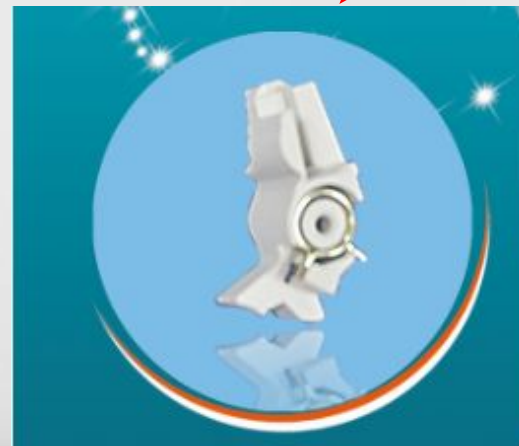
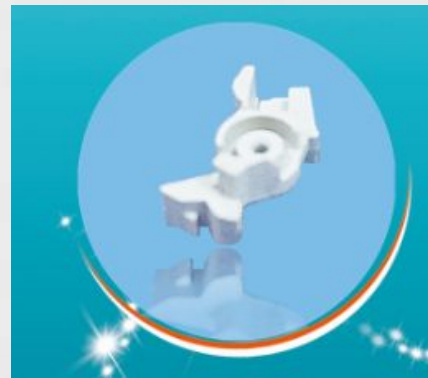



智能点胶机

Intelligent dispensing machine





卷尺拉头组装铆压机

Tape pull head assembly riveting pressure machine

卷尺组装机

专利产品 仿冒必究



卷尺拉头组装铆压机

TAPE PULL HEAD ASSEMBLING RIVETING PRESS

1、成品展示



2、设备技术参数

产能	400—600PCS\每小时
电源	单相220V
气源	4-6KG净化压缩空气
外形尺寸	1.5m*1.2m*0.8m

3、设备特点及主要功能

大小铆钉及尺勾振动盘上料，并采用机械手自动上料、衬片采用自动分料及上料、尺带采用人工放料并自动上料、自动收料。

4、设备优势

有效降低用工成本，提高单位时间出品率和良品率，缩短生产周期。





半圆形蜂鸣器组装线

Semicircle buzzer assembly line





继电器设备

Relay equipment

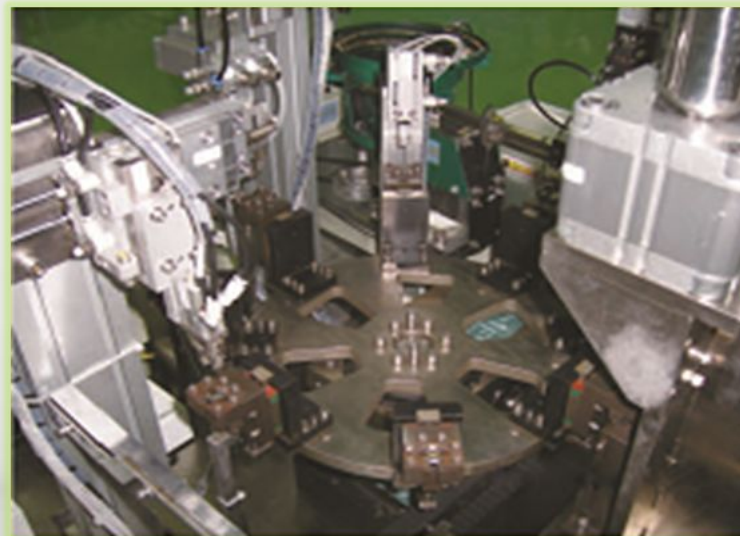



汽车水温传感器组装

Auto water temperature sensor assembly



汽车温控传感器组装设备

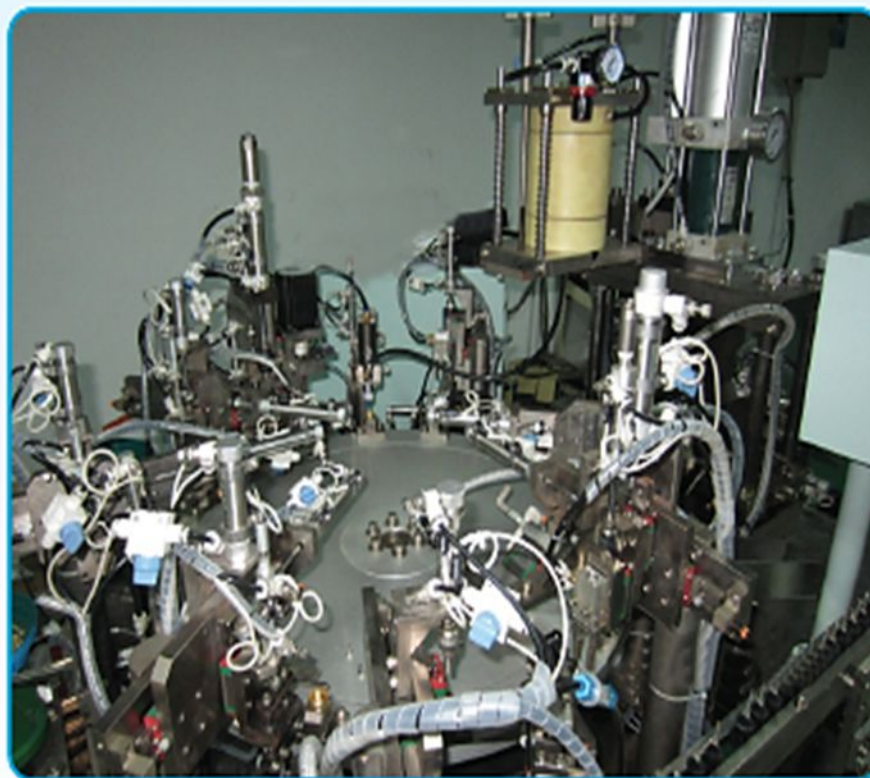

功能特点：

自动上料、自动点胶、
自动卷纸、自动磁环、自动
装弹簧、自动装密封环、自
动装传感器、自动铆压





空调换热器组装线

Air conditioning switch assembly line

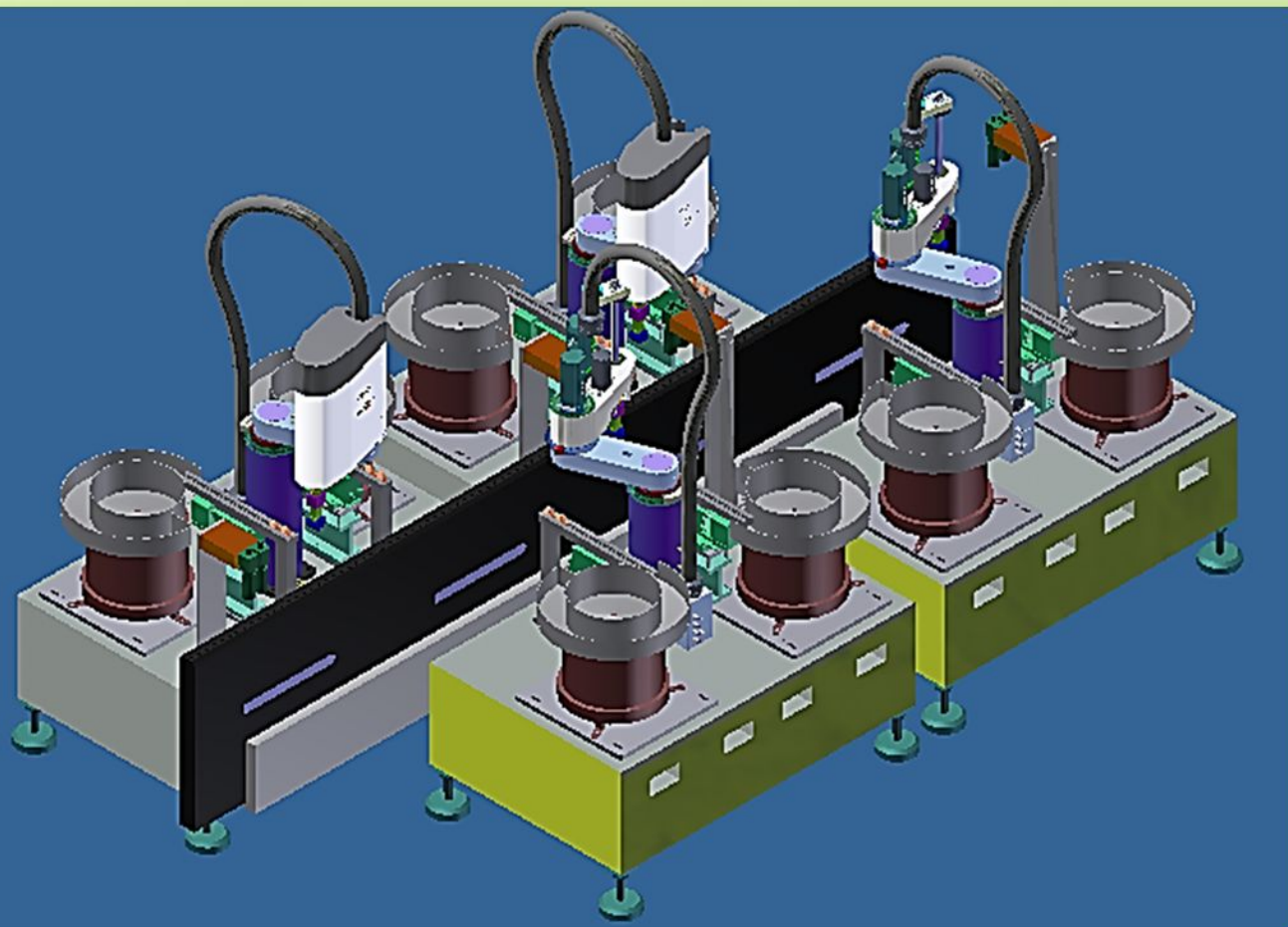

空调换热器弯头组装线由四组组装单元组成。每组单元由料斗供料系统、影像系统和机器人插装系统组成。组装线采用两边错位排列。



比亚迪汽车仪表线路板插装

The car instrument circuit board instrumentation

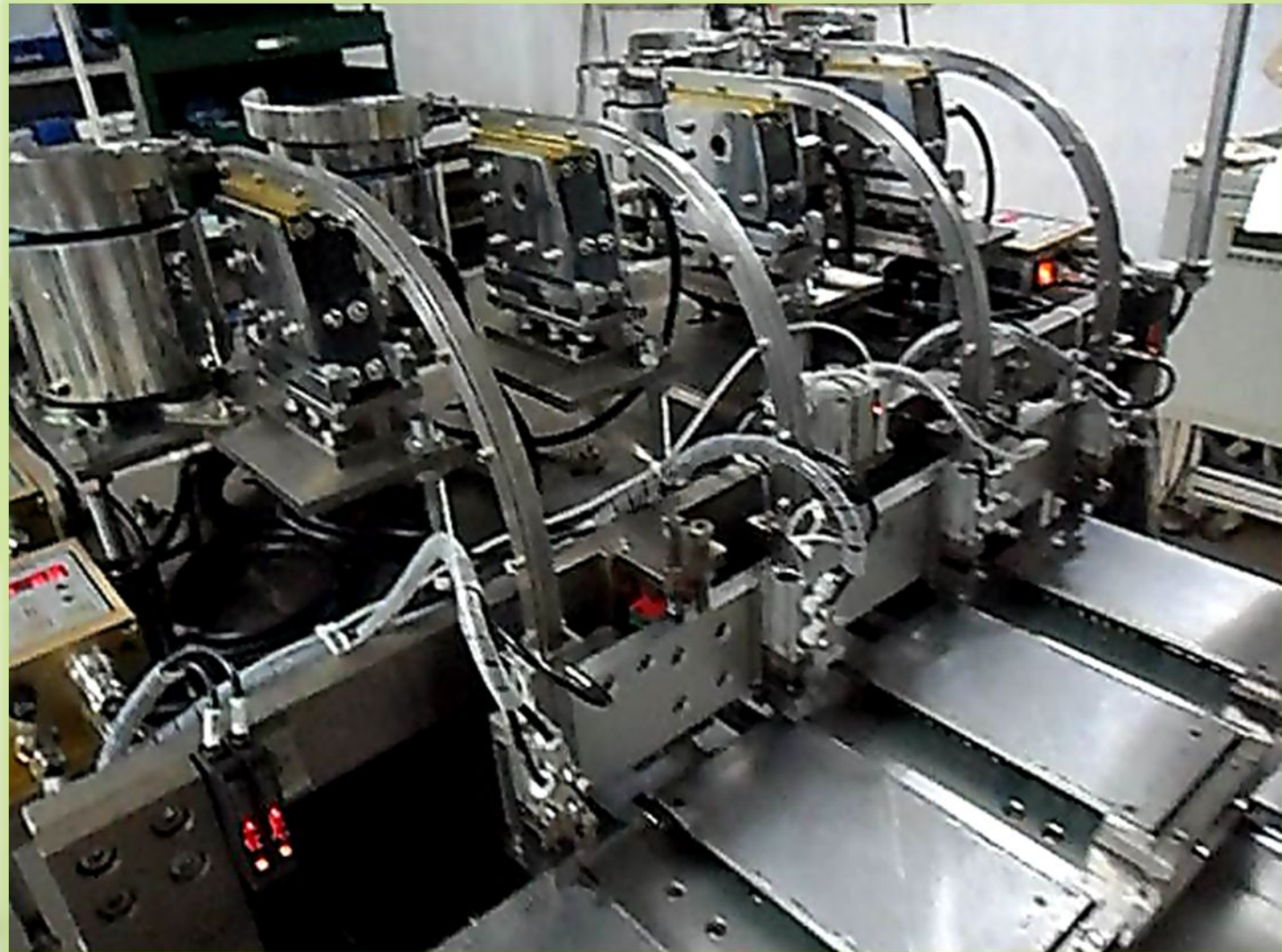



保险丝组装机

fuse group installed

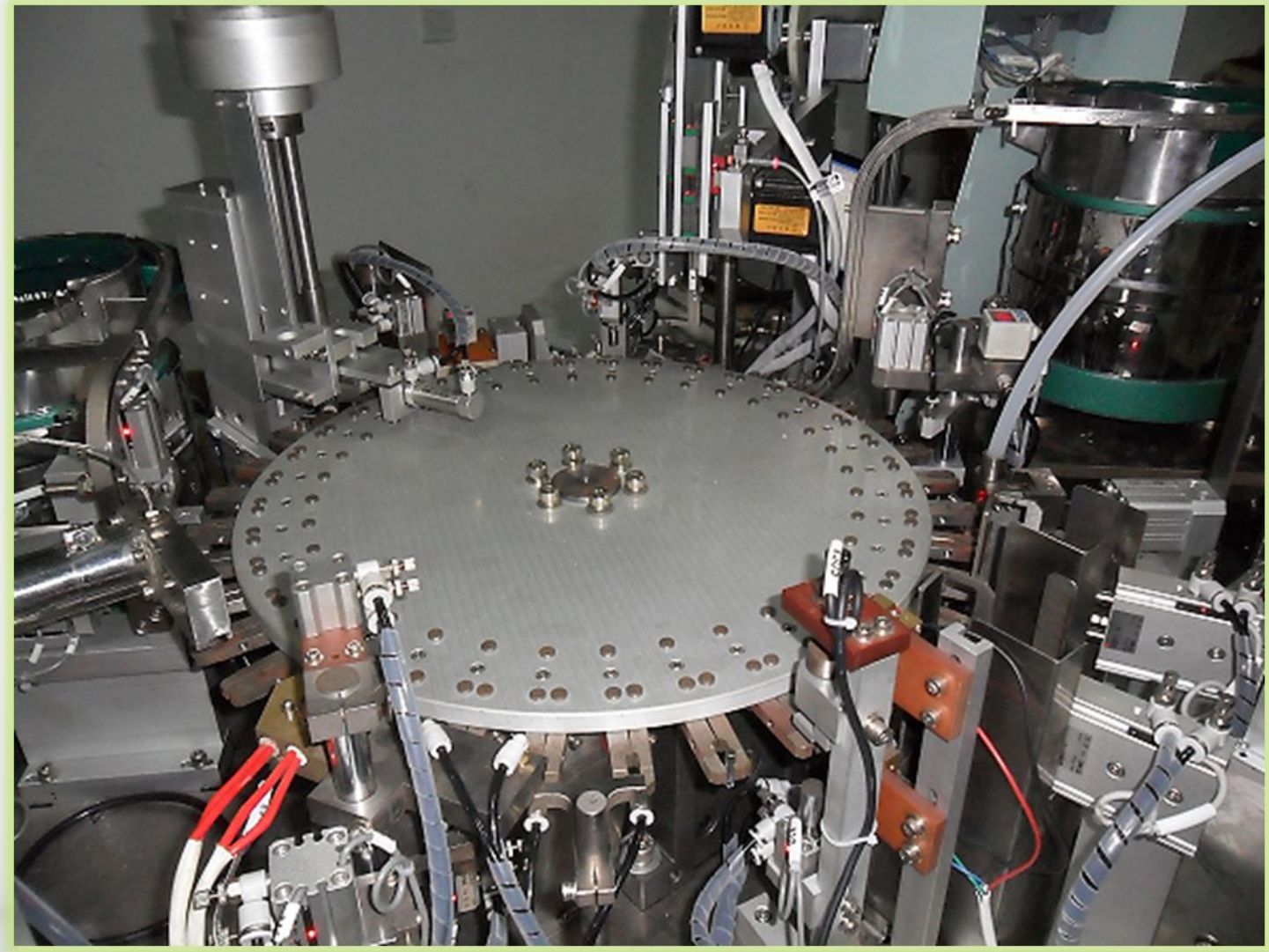



绕线机生产线

Winding machine production line

全自动线圈绕线沾锡生产线



全自动线圈生产线主要由自动插端子机，自动绕线机，自动沾锡机三大部分组成，是集自动上料，自动插端子，自动送料，自动绕线，自动沾锡，自动打弯，自动检测，自动下料于一体的全自动绕线机。





研发平台

Research and development platform

Use 3D design software such as Solidworks, Inventor and CAD

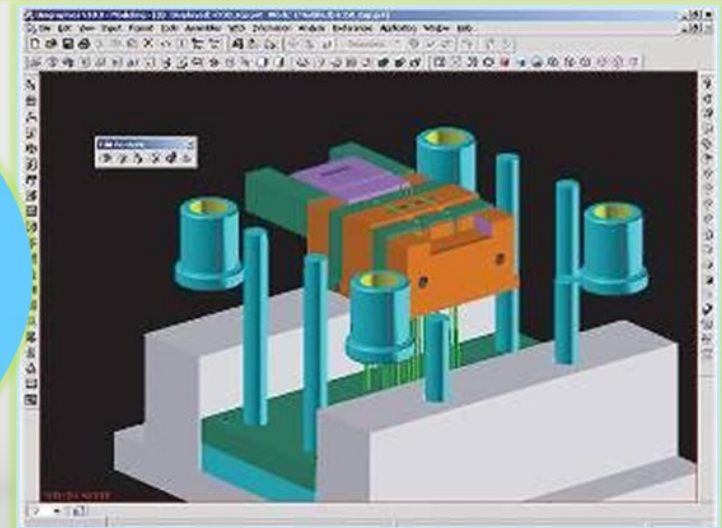
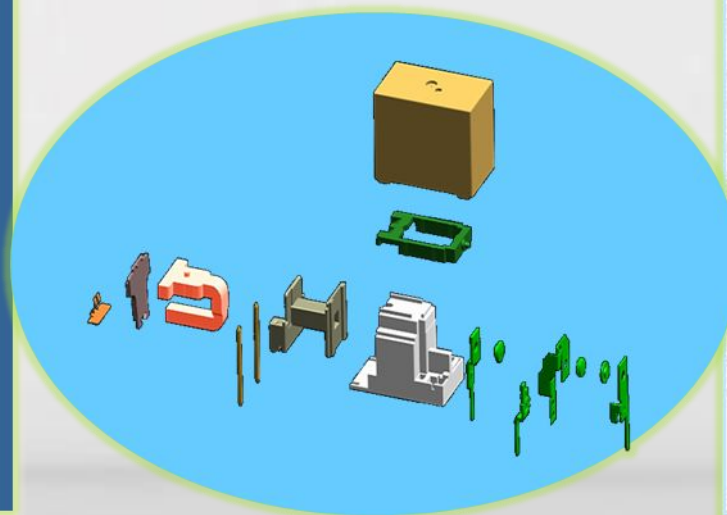
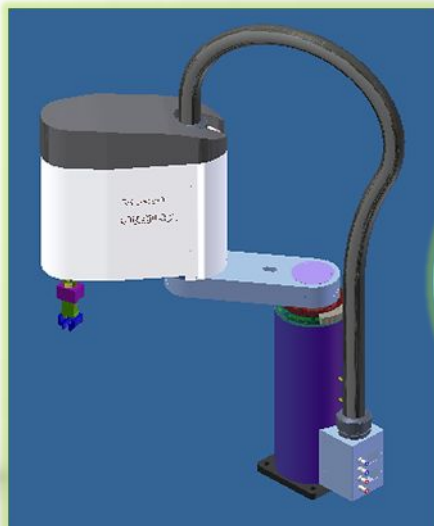
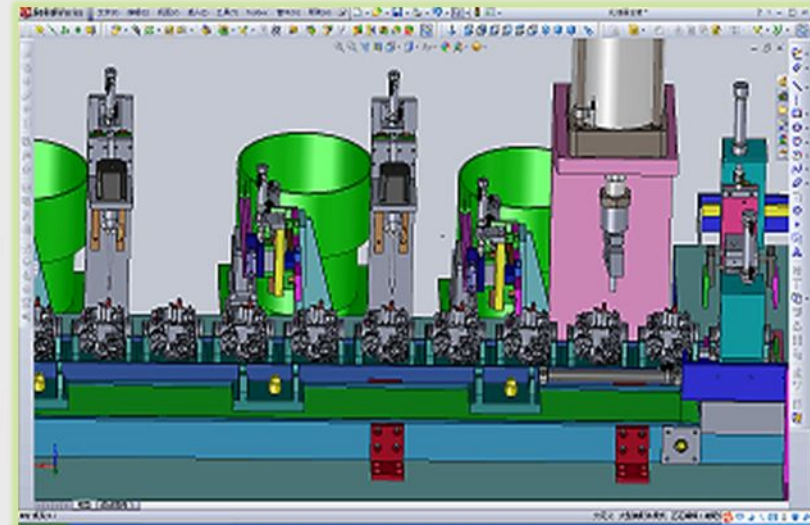

应用领域

Application field





目录

公司介绍
Company profile

01

研发设计
Research and development

02

产品体系
Product system

03

服务体系
Service system

04

竞争优势
Competitive advantage

05





服务特色

Service features

- Vendor level
 - All service outlets and technical service engineers shall be trained and assigned by the headquarters
 - "All-weather no fakes" quick service
- Professional
 - All engineers are well trained and have many years of experience
 - Standardized service

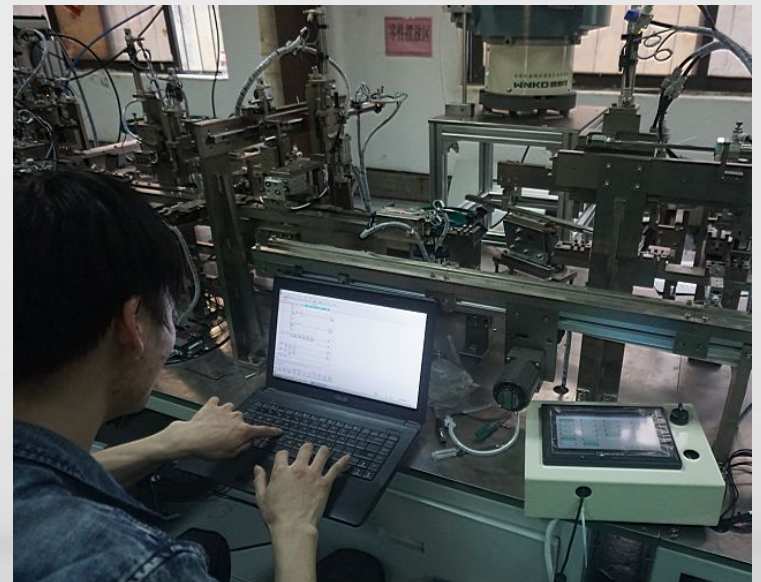



目录

公司介绍
Company profile

01

研发设计
Research and development

02

产品体系
Product system

03

服务体系
Service system

04

竞争优势
Competitive advantage

05





竞争优势

Competitive advantage



Concept
advantages

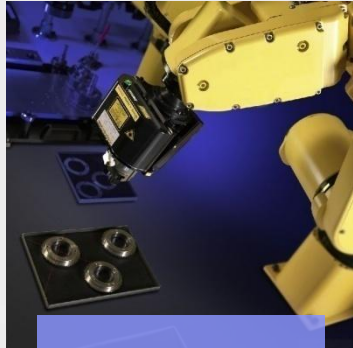

Technical
advantages



resource
advantage



Cost
advantage



Service
advantage





THANKS

机器换人 让世上没有难做的实业

Machine substitution .There is no difficult industry



18900220819 13799269189



gavin@pcccd.co



m

<http://www.pcccd.com>