



Dongguan Pinyi Automation Technology

Committed to deliver quality

Dongguan PINY Automatic Technology Co. Ltd



01

The Robot selection

02

The fixture Structure

03

The Air cylinder

04

The investment and plan

05

The machine information

06

The gage information

1.The Robot Selection

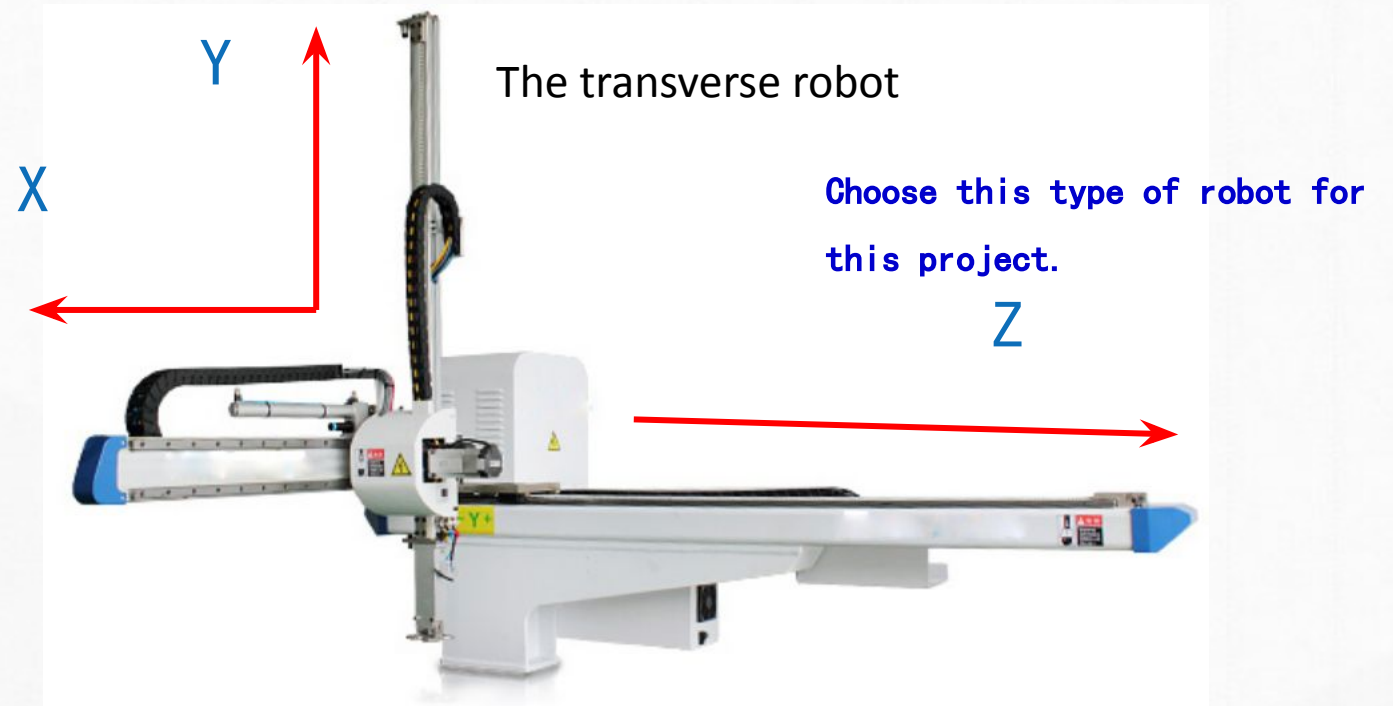
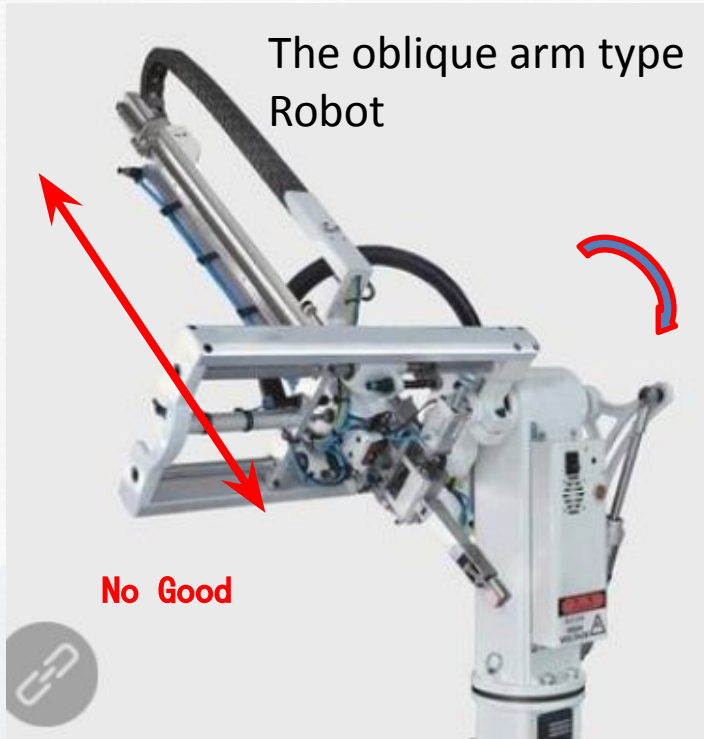

1.The oblique arm type robot can just clamp the runner; it is much simple and can't stall the fixture; which could be 2KG weight; also it can rotate and move up and down.

2.The transverse robot is much common use to catch the housing with the fixture; which is much strong, with precision position location; and it can move forward XYZ direction;

3.The cycle time for the transverse robot movement is about 2~3 seconds.

2.The Fixture Structure

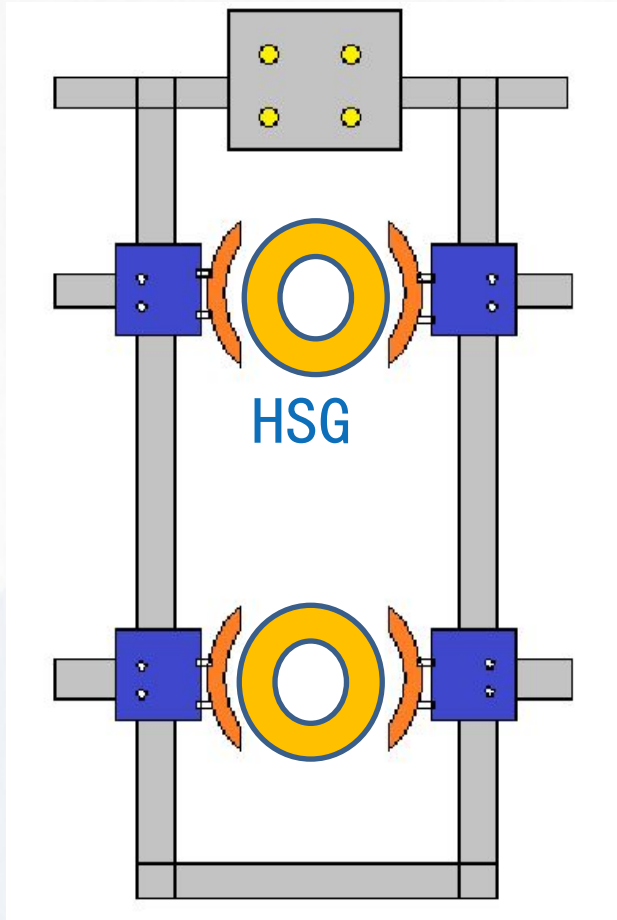

Supporting plate

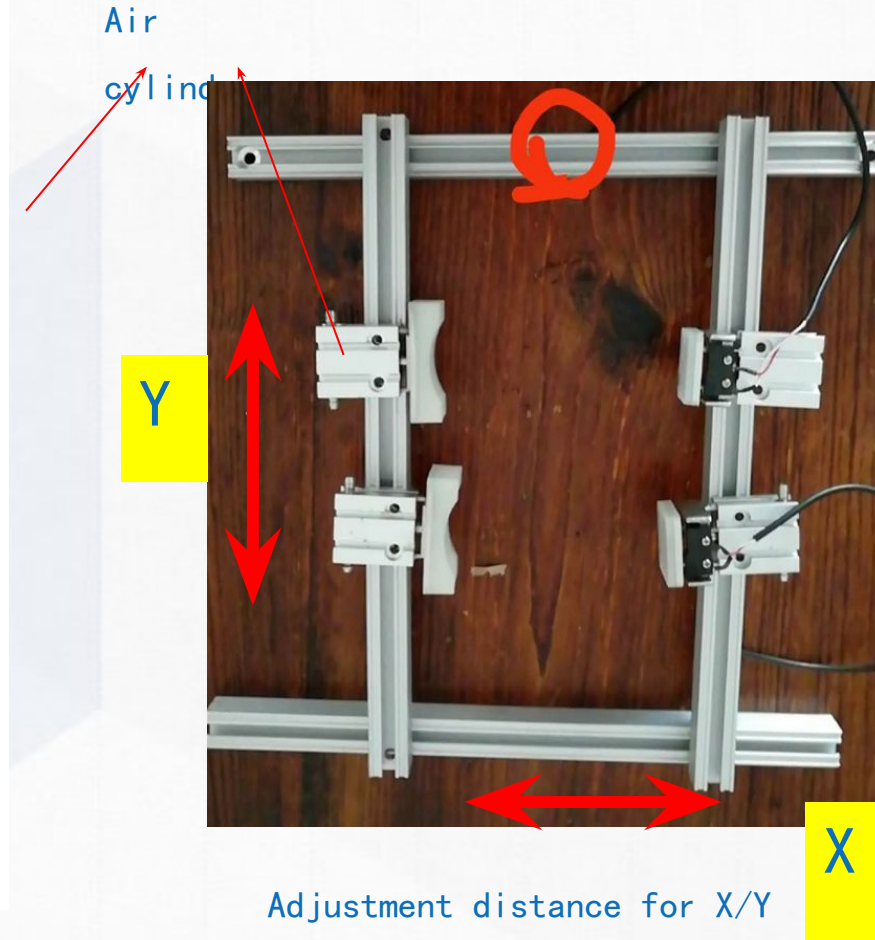

Adjustment distance for X/Y direction by manual

1. This type of fixture is just for 2 cavities mold; 4 air cylinders is installed in the fixture.
2. It can be adjusted distance for X/Y direction to fix the housing by adjusting the screw.

2.The Fixture Structure

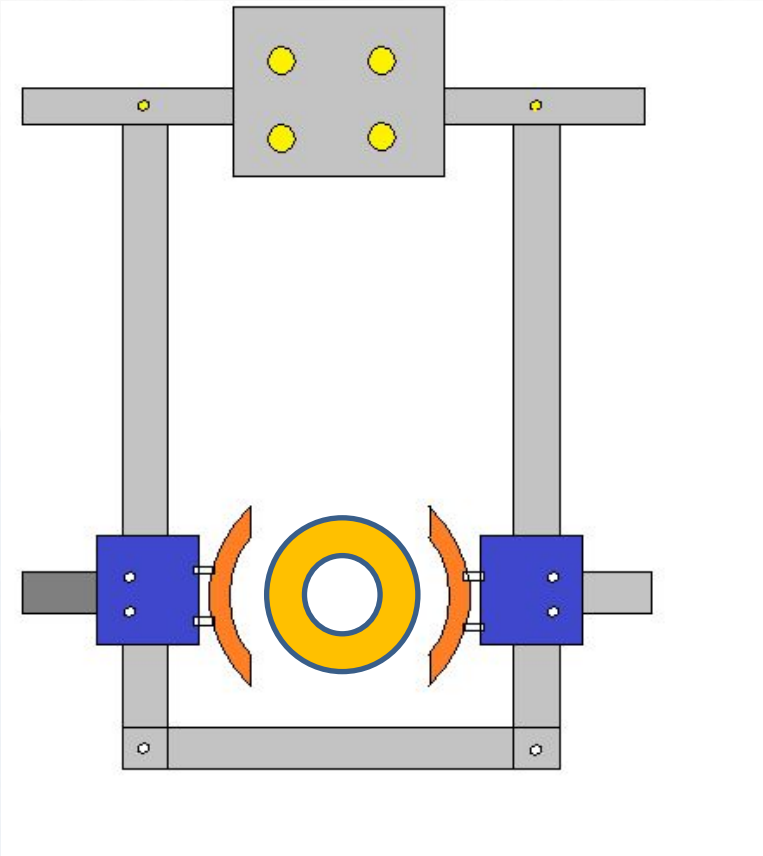

1. This type of fixture is just for one cavities mold; 2 air cylinders is installed in the fixture.
2. It can be adjusted distance for X/Y direction to fix the housing by adjusting the screw.

3.The fixture structure



It is recommended to not use this kind of clamps

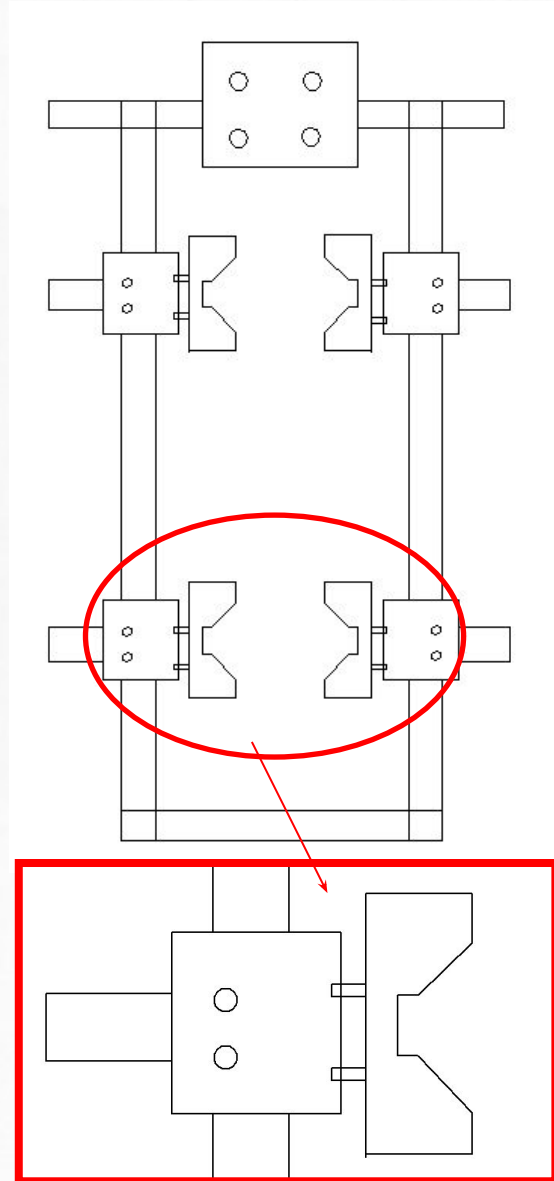

1. The clamps is made by the silica gel, and it is soft and would not damage the housing in the clamping;
2. It is very common use this kinds of clamp and it is the standard for the robot fixture.
3. We has the confidence and experience to use this kind of circle clamps with the silica gel, and ensure no any damage or warpage for the housing.

No common use

3.The Air Cylinder



1. It is the air cylinder for the robot fixture; also it is the standard spare part for the automatic design; which is very common use in the injection area;
2. It is controlled by the air; also it can has the signal control for electrical.
3. The lead time is for two weeks. And the totally cost is 7KUSD for two sets of robot and fixture



4.The investment and plan



Item	Description	quantity	COST	Accomplish date
1	The standard robot for the demag injection machine and fixture	1	3.5KUSD	Two weeks



5.The machine information



Waiting for customer prompt advice and suggest for the project improvement;

Reminds: Customer could provide the injection machine's information; such as

1. The brand of injection machine;
2. The height from the injection nozzle to the top of the machine;
3. Threaded hole location drawing for robot installation.

5.The machine information

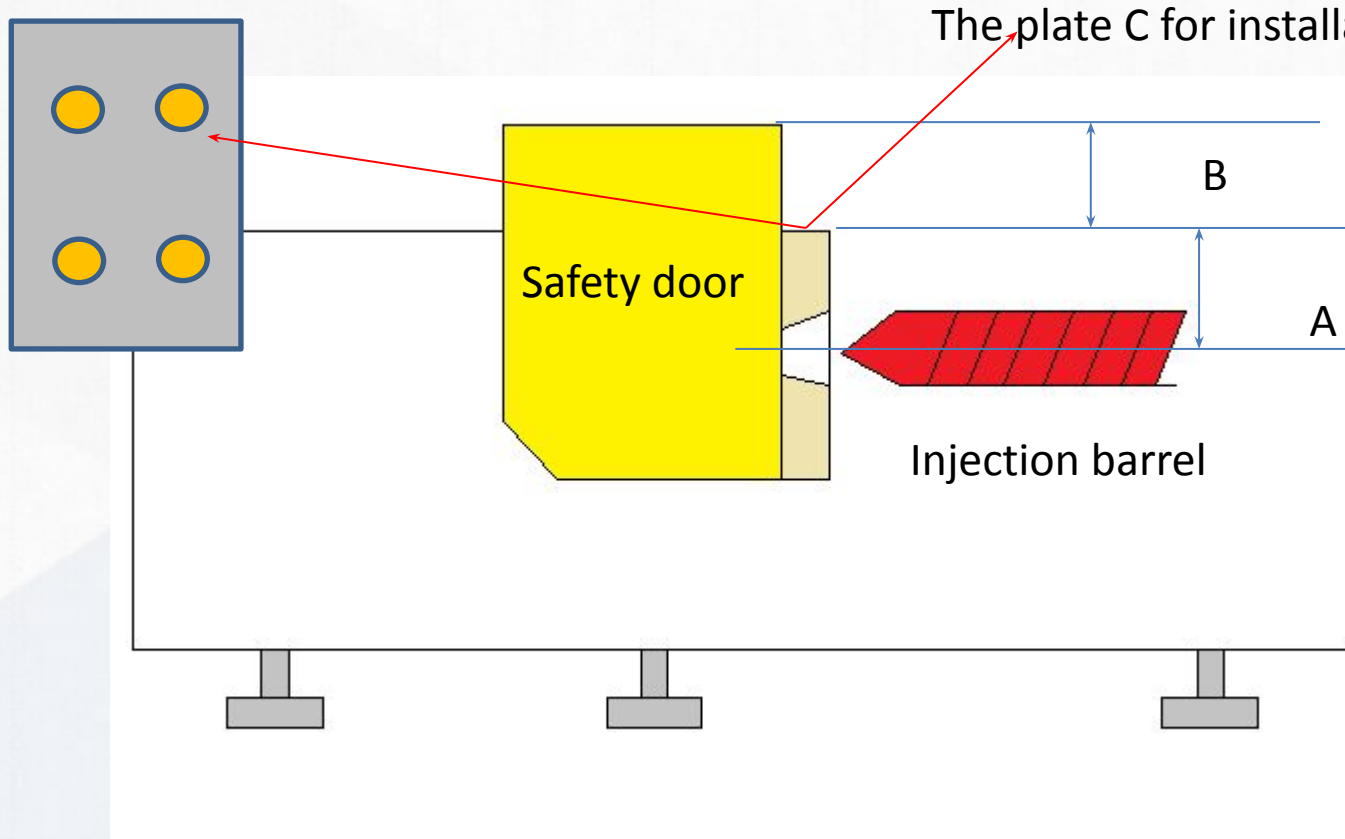

ED: A=307,5 mm.
B= 273,5 mm

- 1.A. The height between center of the injection barrel to the top of the plate C.
- 2.B. The height between top of the plate C to the edge of safety door.
- 3.Provide the detailed thread hole drawing for robot installation.

Customer would provide the drawing of injection machine, specially define the height of A/B; which is the key to select the type of robot; and avoid the fixture to hit the safety door, and avoid other safety risk.

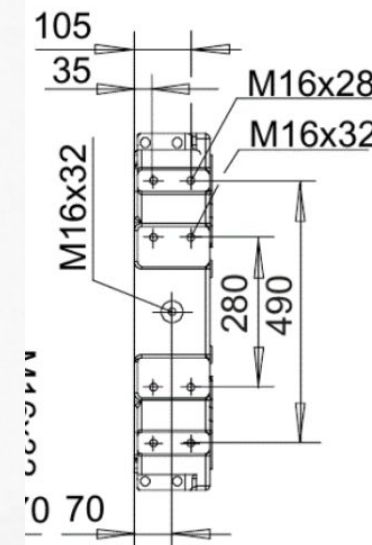

- The plate thread hole spec drawing.

5.The machine information

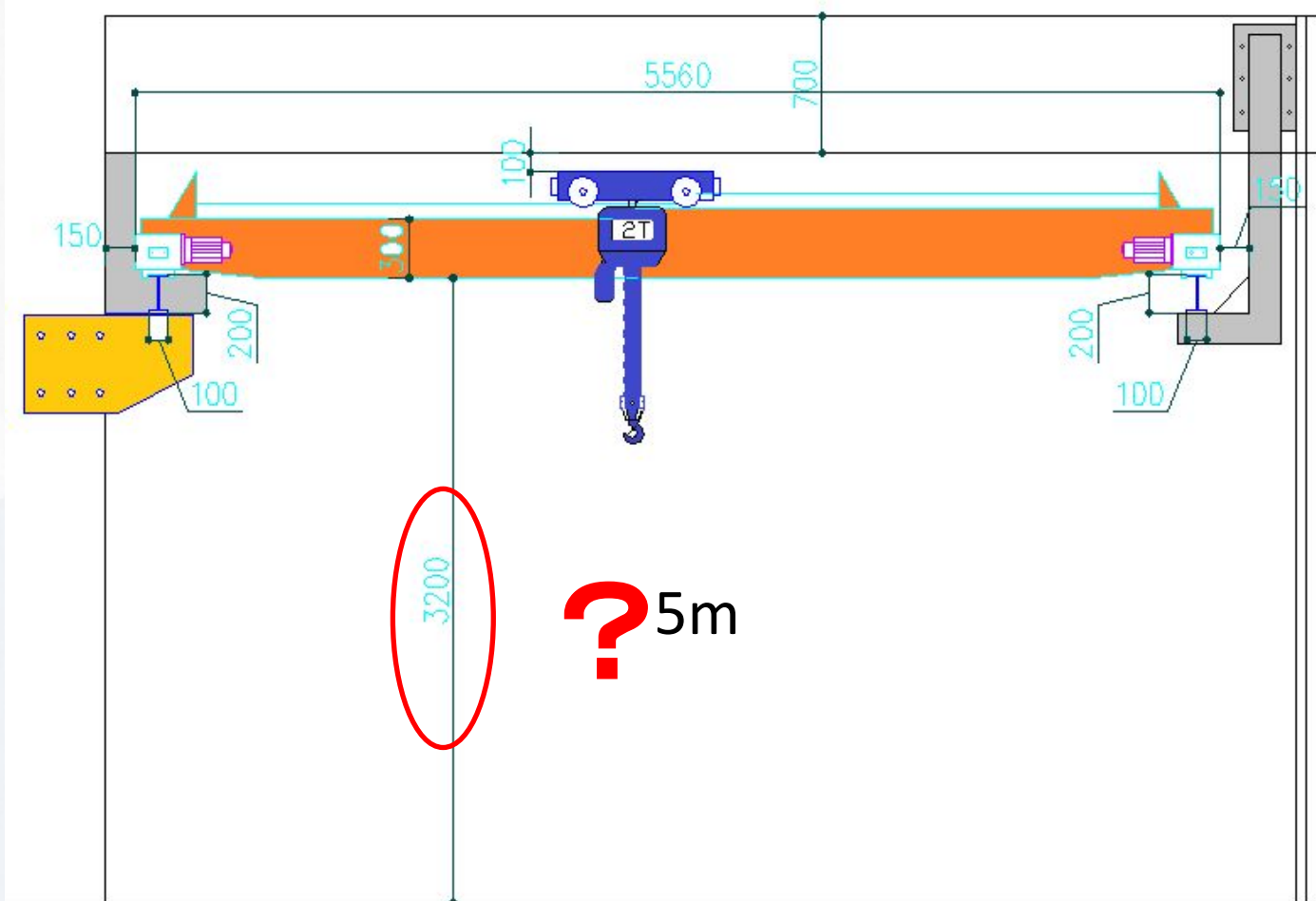

Workshop's travelling Crane

- The height of the travelling crane is 5m +in the customer molding workshop.

6.The Gauge Information



Item	Description	Y2019 Gauge provided by customer	Drawing Spec	Marking of word	Y2020 Gauge Dim
1	M65V-01/02	70.60 71.006	70.4+0/-0.12	0.10mm	70.43 Max
2	M65-01/02	67.509 67.186	67.00+0/-0.12	0.10mm	67.03Max
3	M53-01/M53-02	55.09 54.81	54.6+0/-0.12	0.10mm	54.63Max

1. Please help to double confirm the Dim of the gage ring provided by customer Y2020.
2. As the height of the marking is 0.10mm, the outside dim of the housing for M53 is 54.60 Max(drawing), which means that the **actual** out circle of the ring will be **54.50max** (54.60-0.10)
3. Compare with Y2019 Gage, it is almost **0.20mm smaller**; and housing would be **0.30mm smaller** than before.(As the marking height is 0.10mm)



Check gage

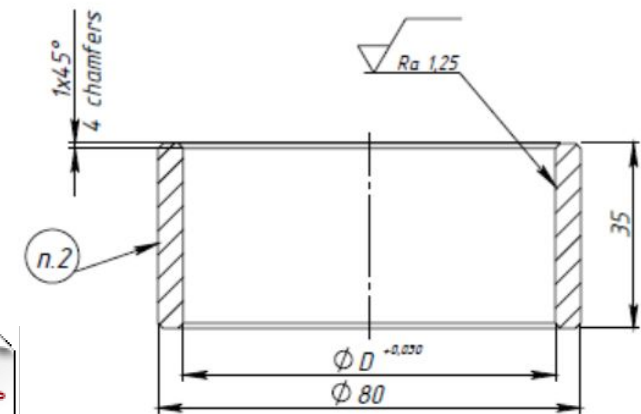

6.The Gauge Information

1. As the outside of ring is 0.30 smaller than before, so the inner ring would also become very smaller (about 0.30) than before, as ensure the thin of the wall is the same and uniformity.
2. So Dim of the inner ring for $50.30^{+0.10}/_{-0.10}$ will not control in the drawing ; and it depend on the actual mold spare part and actual samples.

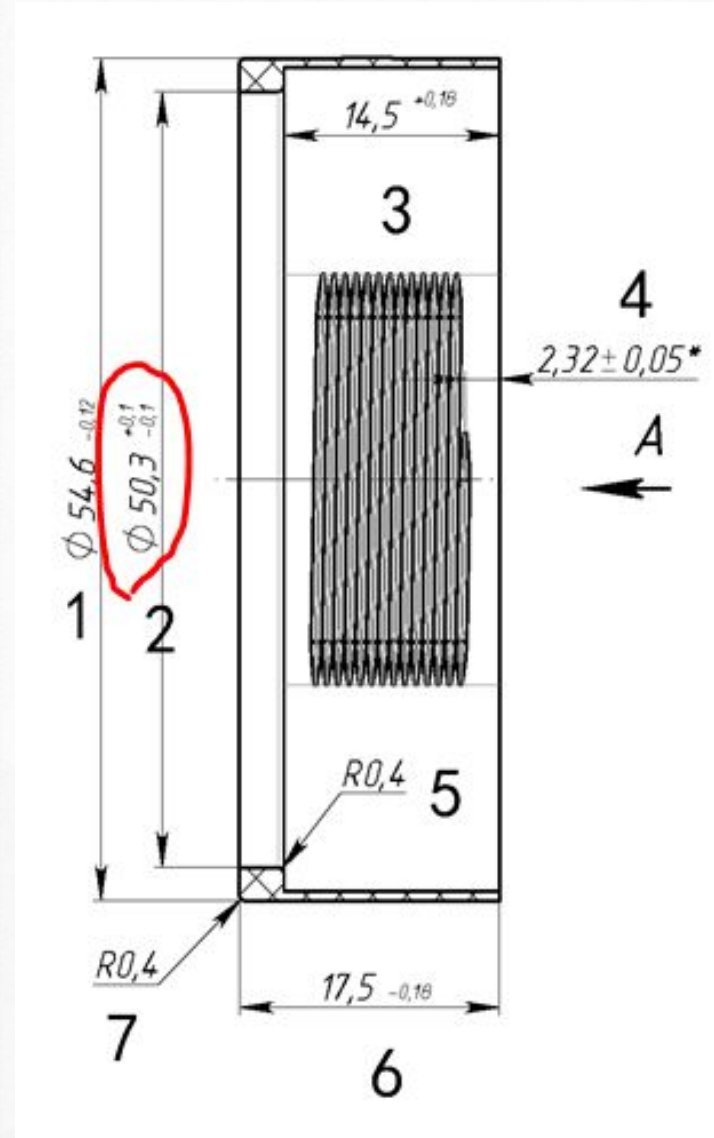

7.The Robot signal connecting with machine



德马格		允许关模	X300 (3) X300 (1)
开模完	KD6	允许顶进	X300 (4) X300 (1)
			模区安全
安全门	KD8	允许开模	

Demag signal		Permit mold close	X300 (3) X300 (1)
			After mold open
Safty door	KD8		

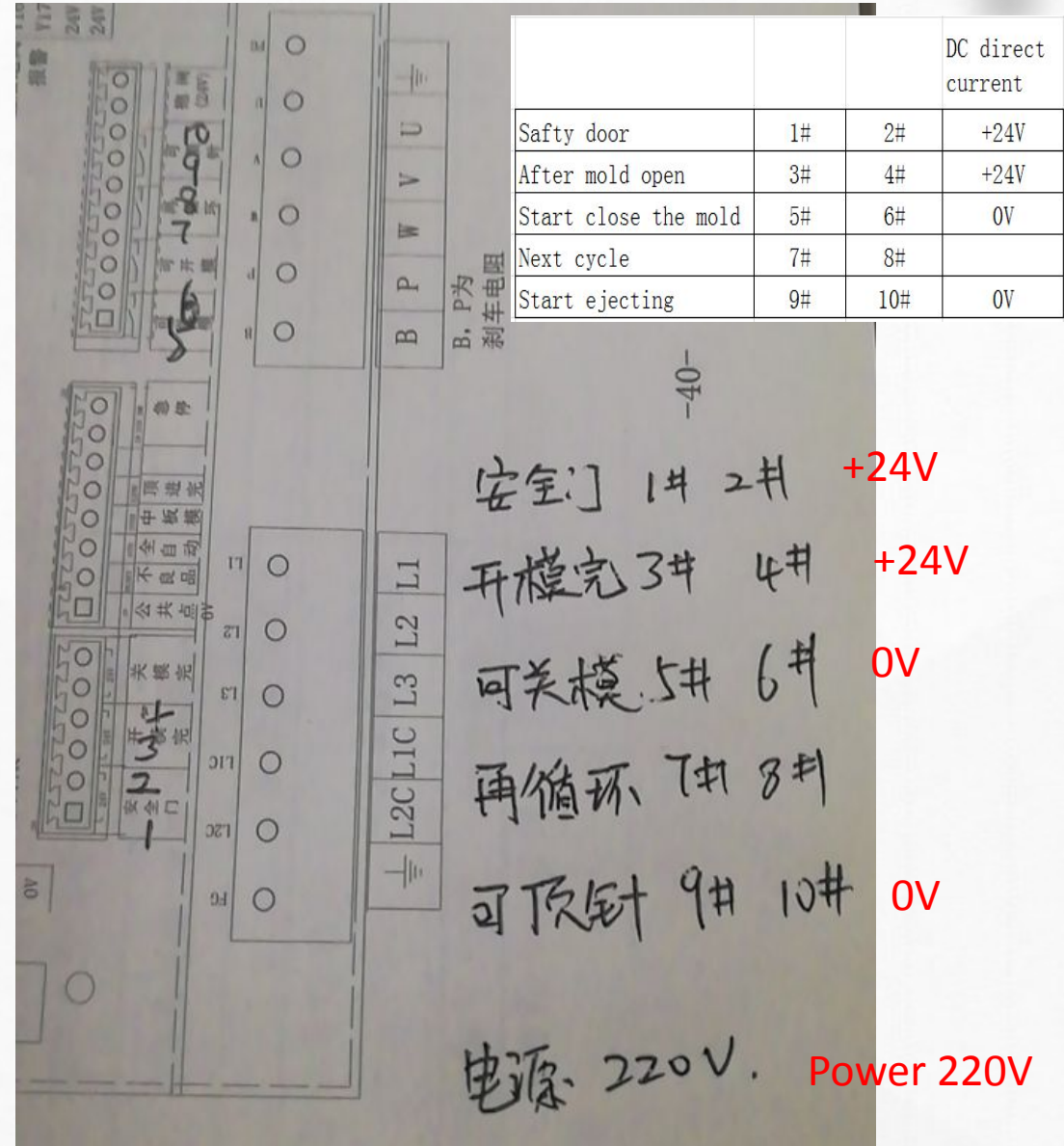

The photograph shows a terminal block with 10 pins. Handwritten labels in Chinese identify the signals: 安全门 (Safty door), 开模完 (After mold open), 可关模 (Start close the mold), 再循环 (Next cycle), and 可顶针 (Start ejecting). A wiring diagram is overlaid on the image, showing connections to a DC power source. A table on the right side of the image provides the DC voltage for each signal.

Signal	Pin 1	Pin 2	DC direct current
Safty door	1#	2#	+24V
After mold open	3#	4#	+24V
Start close the mold	5#	6#	0V
Next cycle	7#	8#	
Start ejecting	9#	10#	0V

Additional handwritten notes include: 安全门 1# 2# +24V, 开模完 3# 4# +24V, 可关模 5# 6# 0V, 再循环 7# 8#, 可顶针 9# 10# 0V, and 电源 220V. Power 220V.

1. Use the multimeter to testing the DC voltage; ensure the signal is right connecting; Signal is +24V; and power is +220V



9.The information/decision provided by customer

Item	Description	Checked	Date	Remarks
1	The height of the travelling crane in the workshop	Customer	Mar-06	5m in workshop
2	The Robot fixture structure design provided by customer	Customer	Mar-06	Recommend use the original fixture
3	The mold modification proposal for M53, as the screw's structure change	Customer	Mar-06	Not change, keep original
4	What is the standard spec of the combining force between the screw thread and snail teeth; and how to measure?	Customer		
5	Y2020 gage is smaller than Y2019; and outside of the ring would be 0.25~0.30 smaller than before, and No control of the inner ring.	Customer		
6	Confirm the signal connecting method between robot and machine.	Customer		



8.The mold improvement schedule

Item	Description	Date	Remarks
1	Design the mold 3D and 2D for mold improvement	Mar-09	Need to confirm the check gage by customer
2	Make the new spare parts for 1 cavity mold	Mar-16	
3	Make the new spare parts for 2 cavity mold	Mar-20	As it is more complex, and more spare parts
4	1 cavity mold trial run	Mar-17	
5	2cavity mold trial run	Mar-21	
6	Samples measure and FAI report(1 cavity)	Mar-18	
7	Samples measure and FAI report(2 cavity)	Mar-21	
8	Marking the works(log)	Mar-22	Ensure the new samples is Ok, circle and good Dim; and then marking
9	Make the new check gage	Mar-13	
10	Submit the OK(FAI passes) samples for Alex approval	Mar-23	Send by air express
11	Robot purchase and testing in PinYi	Mar-20	Achieve the robot automatic clamping in the Nessei machine of PINYI



Thanks For Reading !