

# Presentation about Boilers



# Boilers

- A boiler is a closed vessel in which water or other fluid is heated. The fluid does not necessarily boil



- The heated or vaporized fluid exits the boiler for use in various processes or heating applications,[1][2] including water heating, central heating, boiler-based power generation, cooking, and sanitation

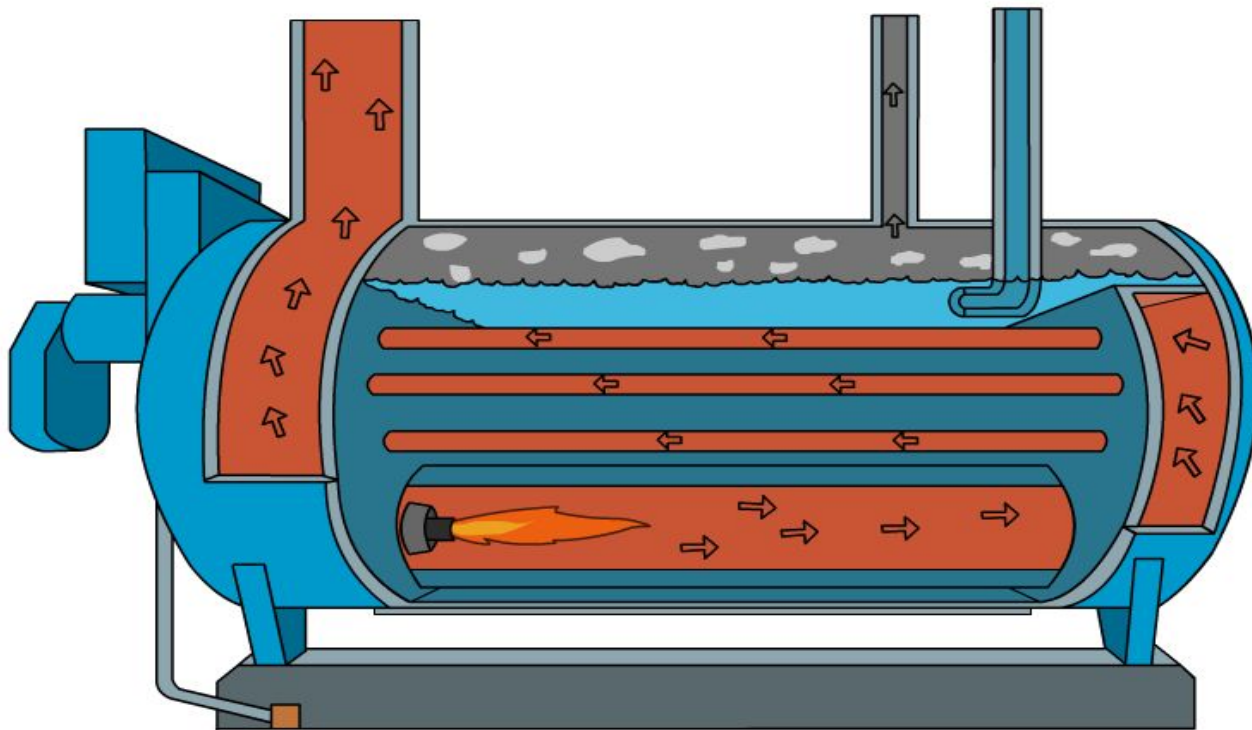



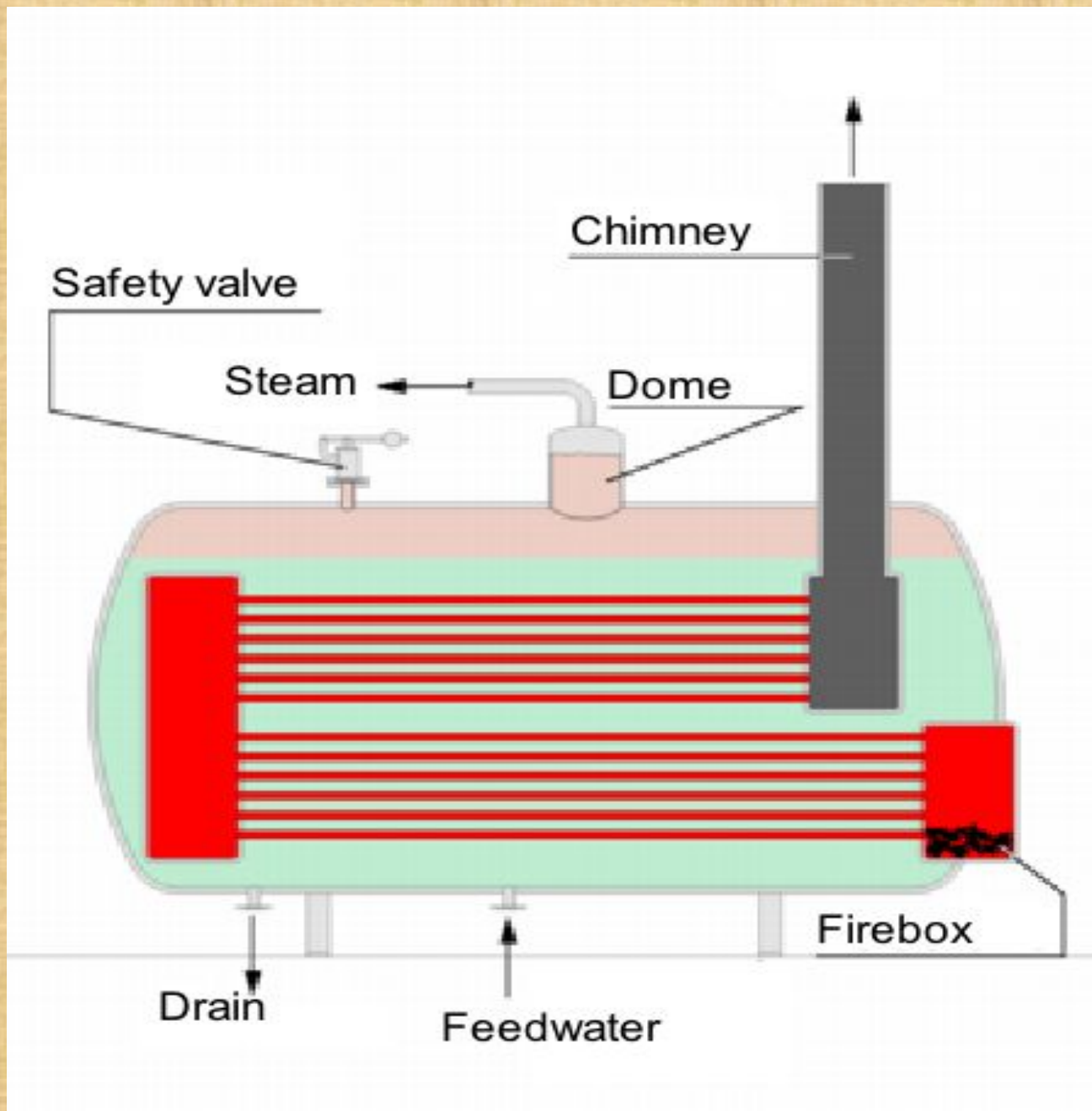

# Boiler efficiency

there are two method to measure the boiler efficiency

- 1) direct method
- 2) indirect method

# Direct method

- Direct method of boiler efficiency test is more usable or more common

$$\text{ККД котла} = Q * (H_g - H_f) / d * \text{GCV} * 100$$

# Indirect method

to measure the boiler efficiency in indirect method we need a following parameter like

- 1)Ultimate analysis of fuel (H<sub>2</sub>,S<sub>2</sub>,S,C moisture constraint,ash constraint)
- 2)percentage of O<sub>2</sub> or CO<sub>2</sub> at flue gas
- 3)flue gas temperature at outlet
- 4)ambient temperature in deg c and humidity of air in kg/kg
- 5)GCV of flue in Kcal/kg
- 6)ash percentage in combustible fuel
- 7)GCV of ash in Kcal/kg

# Types of Boilers

Two primary types of boilers include Firetube and Watertube boilers.

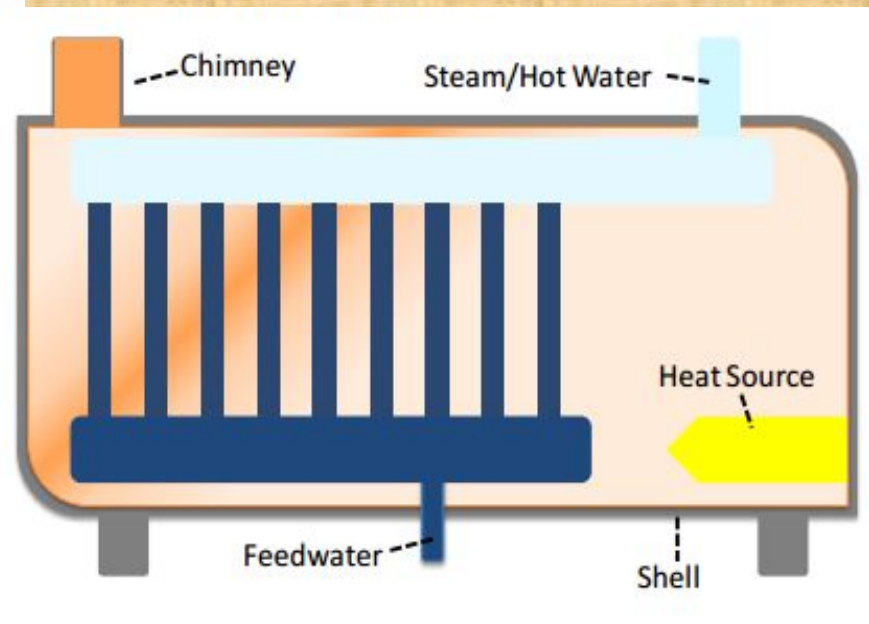
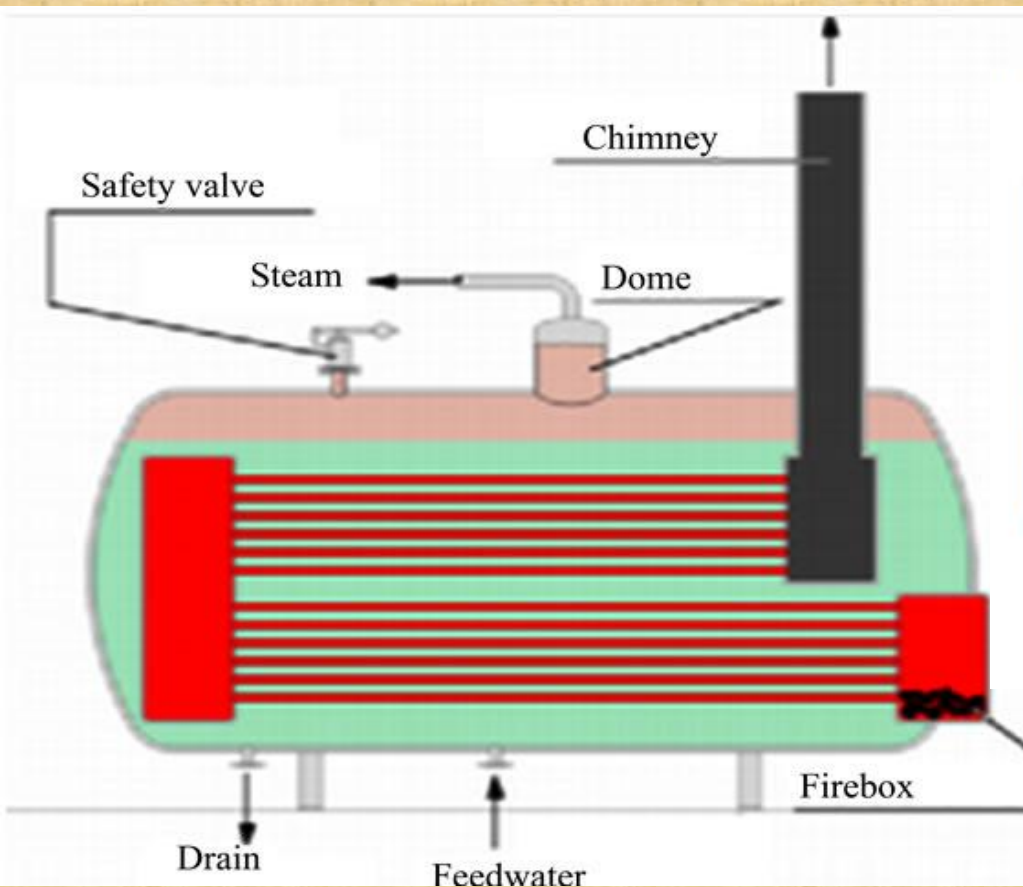



# Cast iron sectional boilers

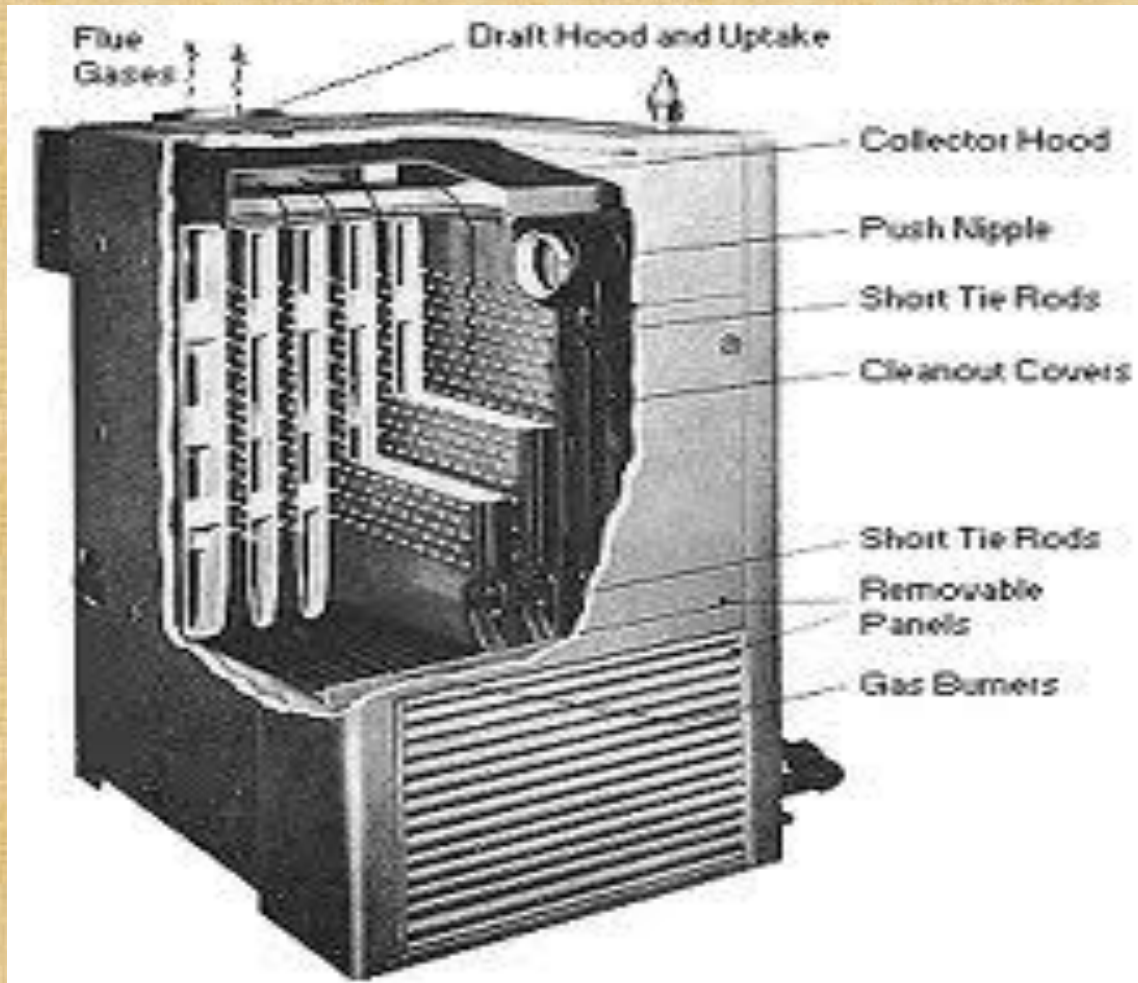

# ***The END***

Prepared  
Student group TS-51s  
Osipchuk Katia

# Function boilers

- Continuous electronic flame modulation in heating and DHW modes;
- Smooth electronic ignition;
- pump post-circulation;
- Built-in weather-automatics;
- Possibility of weekly programming mode and DHW;
- lock protection system pump and three-way valve