

# *WEATHER RADAR SYSTEM*

## *Purpose*

The weather radar (WXR) system supplies these visual indications:

Weather conditions

Windshear events

Land contours.

## ▣ *Description*

- ▣ WXR operates on the same principle as an echo. The WXR system transmits radio frequency (RF) pulses in a 180 degree area forward of the airplane. Objects reflect the pulses back to the receiver. The receiver processes the return signal to show weather, terrain, and windshear events.

## ▣ *Display*

- ▣ The WXR returns show in four different colors on the navigation displays (ND). Colors of the indications give the crew information about the intensity of the returns.

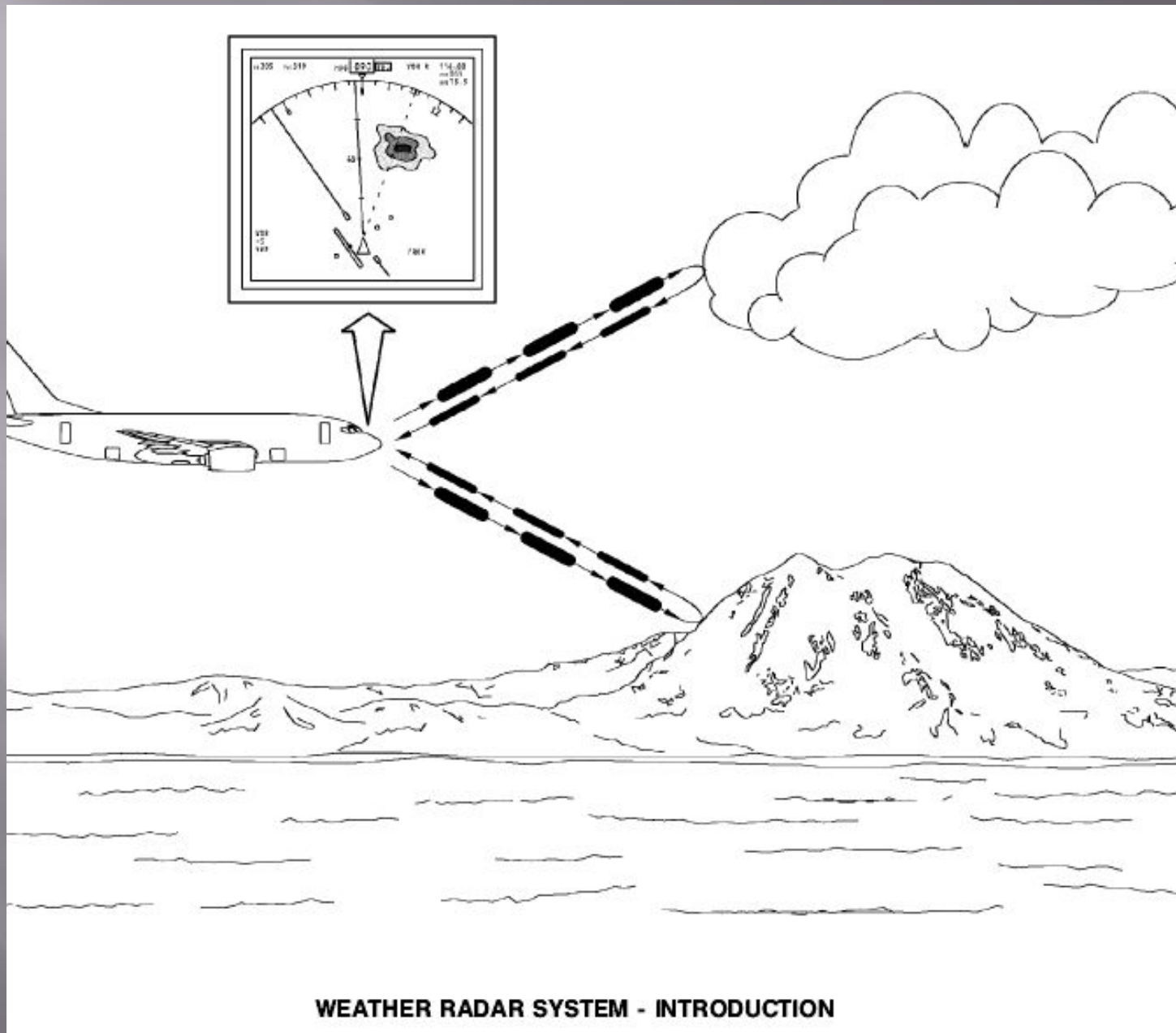

**WEATHER RADAR SYSTEM - INTRODUCTION**

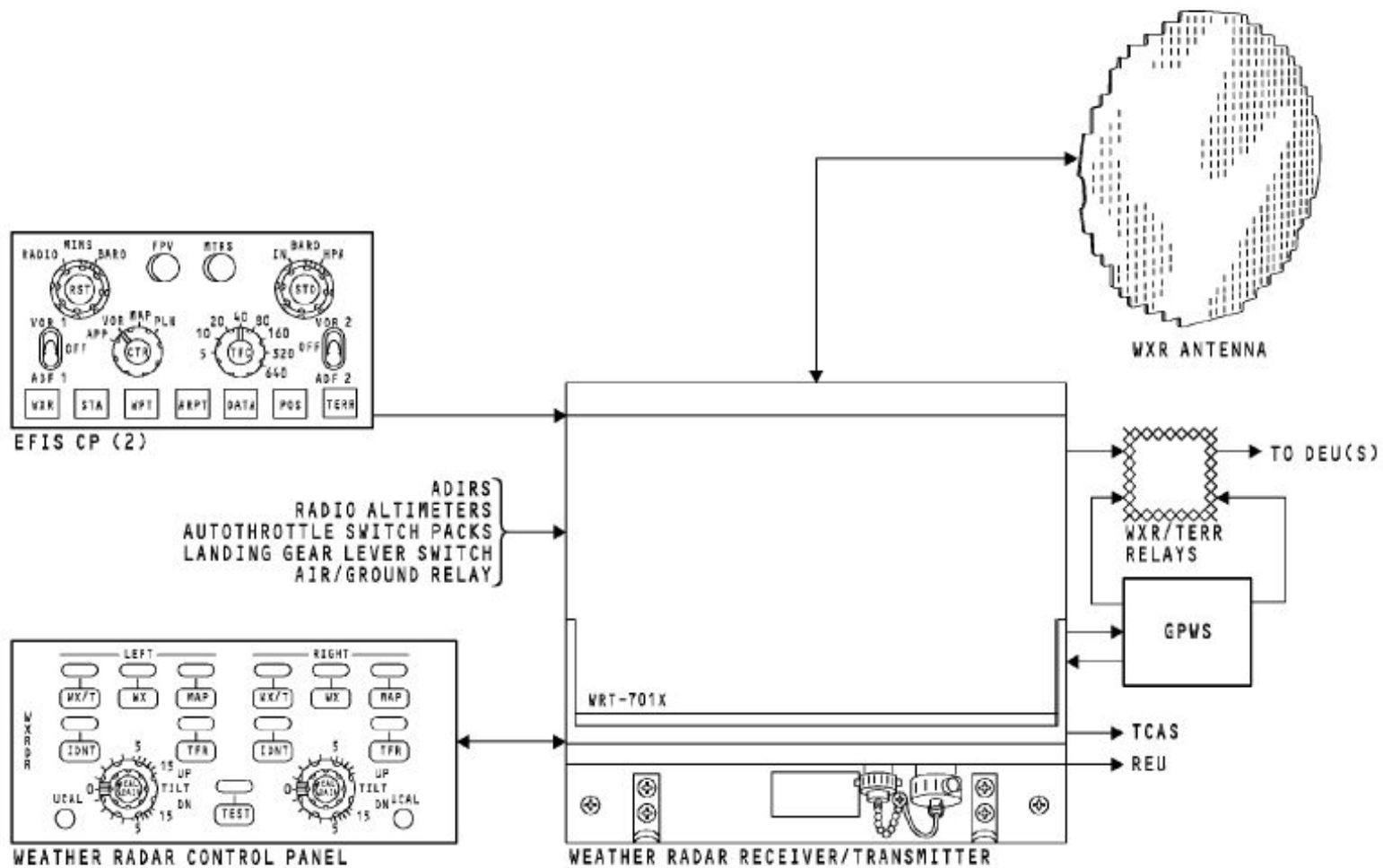

**WXR SYSTEM - GENERAL DESCRIPTION**

## **WXR SYSTEM - COMPONENT LOCATION - FLIGHT COMPARTMENT**

### ***WXR System Components***

The weather radar control panel is on the P8 aft electronic panel in the flight compartment.

### ***WXR System Interface Components***

These are the flight compartment components that have an interface with the WXR system:

- Left EFIS control panel (P7)
- Right EFIS control panel (P7)
- Left inboard display unit (P1)
- Right inboard display unit (P3)
- IRS select switch on the navigation/displays source select panel (P5).

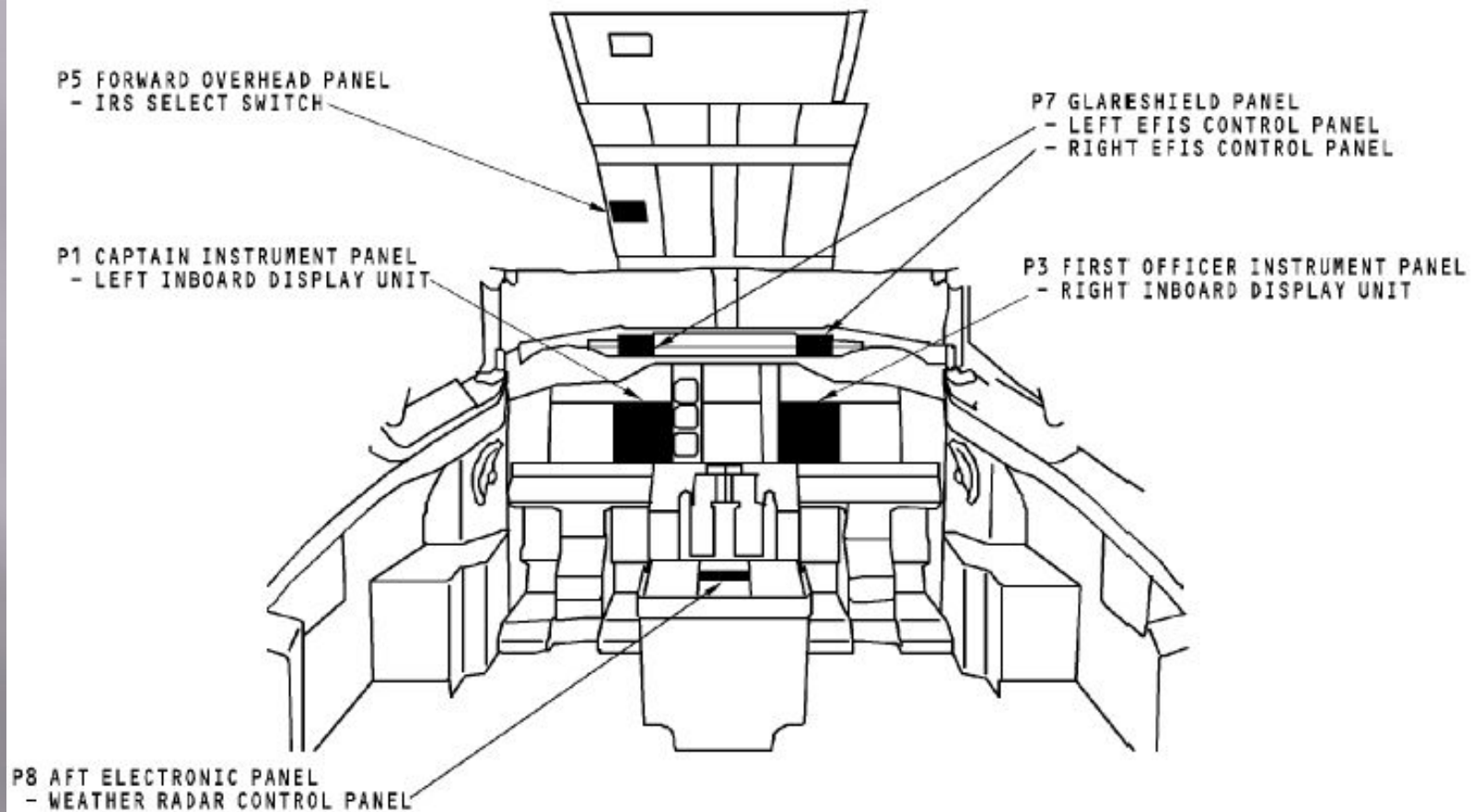

**WXR SYSTEM - COMPONENT LOCATION - FLIGHT COMPARTMENT**

## ▣ WXR SYSTEM - POWER AND ANALOG INTERFACES

### ▣ *System Power and ON/OFF*

- ▣ The WXR receiver transmitter (R/T) gets 115v ac through the WXR RT circuit breaker from the 115v ac XFR BUS 2 (P6 circuit breaker panel). The WXR R/T circuit breaker also sends 115v ac to the WXR R/T mount for fan operation.
- ▣ The left and right EFIS control panels (CP) send the ON/OFF data to display electronics unit (DEU) 1 and DEU 2. The DEUs make sure the navigation display is in a mode that can show WXR data. If the navigation display is in a correct mode, the DEUs send an ON/OFF discrete to the WXR control panel. The ON/OFF discrete goes through the WXR control panel to the WXR R/T. This discrete lets the WXR R/T operate.
- ▣ When the WXR R/T gets the ON signal, it sends 28v dc to the power supply in the WXR control panel and 115v ac to the WXR R/T power supply.
- ▣ The WXR R/T sends a 28v dc power interlock to the WXR control panel. The control panel sends the 28v dc interlock back to the WXR R/T as R/T ENABLE.
- ▣ The WXR antenna gets 115v ac from the WXR R/T.
- ▣ The WXR RT mount gets 115v ac from XFR bus 2 for fan test power. This permits an operational test of the fan when the RT is not installed.

## ▣ *DisCRETes*

- ▣ The GPWS sends an inhibit discrete to the PWS. The discrete inhibits PWS aural alerts if the GPWS alerts are a higher priority.
- ▣ The PWS aural alert will stop when a higher GPWS alert is received.
- ▣ The landing gear lever sends a landing gear down discrete to enable PWS during an approach.
- ▣ The left and right auto throttle switch packs send discrettes (QFR A) to enable the PWS function. When the throttles move through 53 degrees and the aircraft is below 2300 feet RA, the radar turns on.
- ▣ The audio inhibit discrete goes to the TCAS. The TCAS uses this discrete to downgrade all RAs to TAs and inhibit all aural alerts.
- ▣ *RF Transmission and Reception*
- ▣ Transmit radio frequency (RF) goes from the R/T through the waveguide to the weather radar antenna. The receive RF goes from the antenna through the waveguide to the R/T.



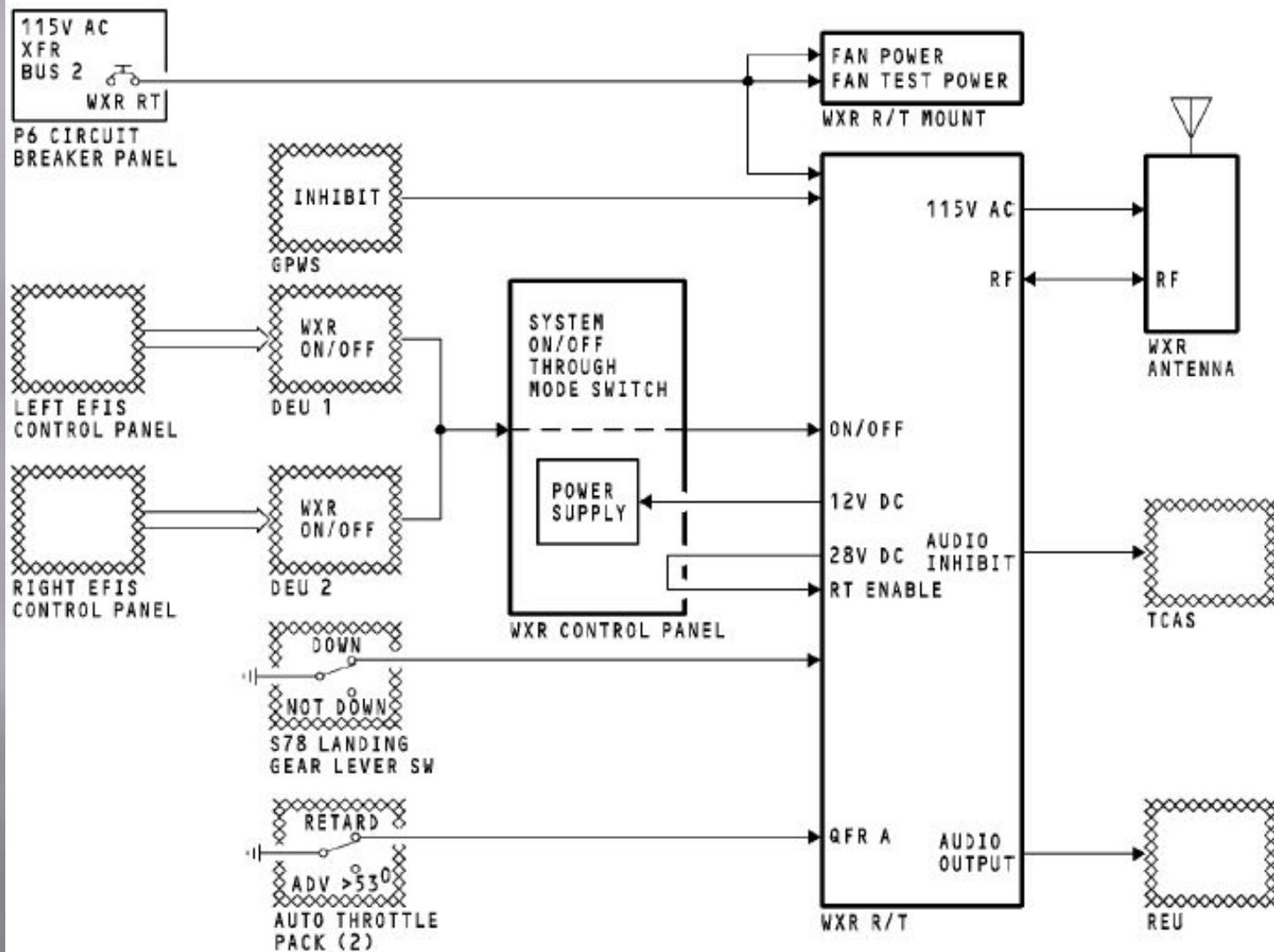

**WXR SYSTEM - POWER AND ANALOG INTERFACES**

## ▣ WXR SYSTEM - CONTROL AND DISPLAY INTERFACE

### ▣ *Digital Inputs*

▣ The WXR R/T receives data from these systems:

▣ Air data inertial reference system (ADIRS)

▣ Radio altimeter (RA) system

▣ Common display system (CDS).

▣

### ▣ *Air Data Inertial Reference System*

▣ The ADIRS sends this inertial reference (IR) data to the WXR R/ T on a high-speed ARINC 429 data bus:

▣ Pitch angle

▣ Roll angle

▣ Groundspeed

▣ True heading

▣ Magnetic heading

▣ Drift angle

▣ Discretes.

- ▣ WXR SYSTEM - ANTENNA CONTROL INTERFACE

- ▣ *Antenna Tilt*

- ▣ The WXR panel supplies antenna tilt control signals to the WXR R/T.

- ▣ *Attitude Sources*

- ▣ The WXR R/T uses ADIRU attitude data to stabilize the antenna. The left ADIRU signals connect to the on-side attitude input of the WXR R/T. The right ADIRU signals connect to the off-side attitude input of the WXR R/T.

- ▣ *Attitude Source Select Discrete*

- ▣ Use the IRS select switch to choose the ADIRU source to the WXR R/T. Set the switch to NORMAL or BOTH ON L to use the left ADIRU input. Set the switch to BOTH ON R to use the right ADIRU input.

- ▣ *WXR R/T Antenna Control*

- ▣ The WXR R/T sends signals to the WXR antenna assembly to control it and make it stable.

- ▣ *Antenna Position Monitoring*

- ▣ The WXR antenna sends antenna position data to the WXR R/T for scan and elevation feedback.

- ▣

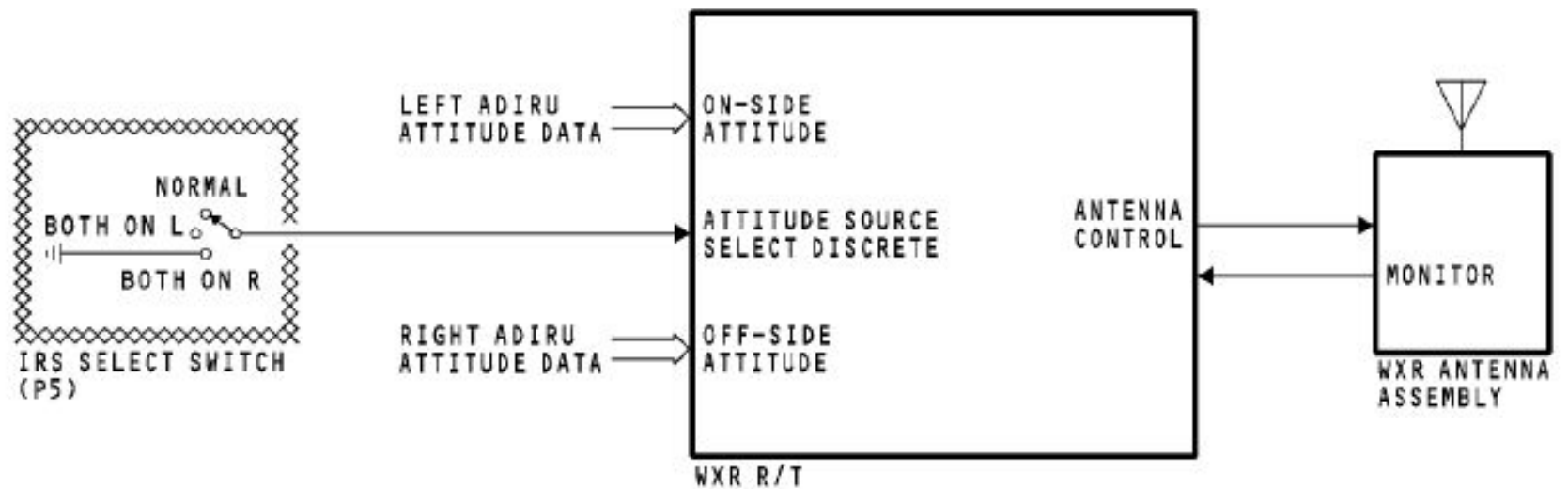

**WXR SYSTEM - ANTENNA CONTROL INTERFACE**

## ▣ WXR SYSTEM - CONTROL PANEL

### ▣ *General*

▣ The weather radar (WXR) control panel has these functions:

▣ Mode selection

▣ Tilt control

▣ Gain control.

### ▣ *Mode Selector*

▣ The captain and first officer can show separate weather radar displays. The control panel has these mode switches:

▣ TEST - starts a self-test of the R/T and shows the test results on the NDs

▣ WX - R/T shows the weather data on the NDs

▣ WX/T - R/T shows weather and turbulence data on the NDs.

▣ The turbulence range is up to a maximum of 40 nautical miles (NM). If a range more than 40 NM is set on the EFIS control panel, the NDs show weather data only .

▣ MAP - R/T shows ground and terrain features on the NDs

▣ IDNT - starts ground clutter suppression

▣ TFR - push the left transfer switch to transfer the right side mode, tilt, and gain to the left side display.

- ▣ *Tilt Control*

- ▣ The tilt control adjusts the antenna tilt angle from +15 degrees to -15 degrees.

- ▣ *Gain Control*

- ▣ The gain controls adjust the gain for the WXR R/T signal returns. The switches have 10 detented positions. Turn the switch full clockwise for the CAL position. In the CAL position, the gain is set to a calibrated level by the R/T.

- ▣ *UCAL Annunciator*

- ▣ The UCAL annunciators show when the GAIN controls are in the uncalibrated position.

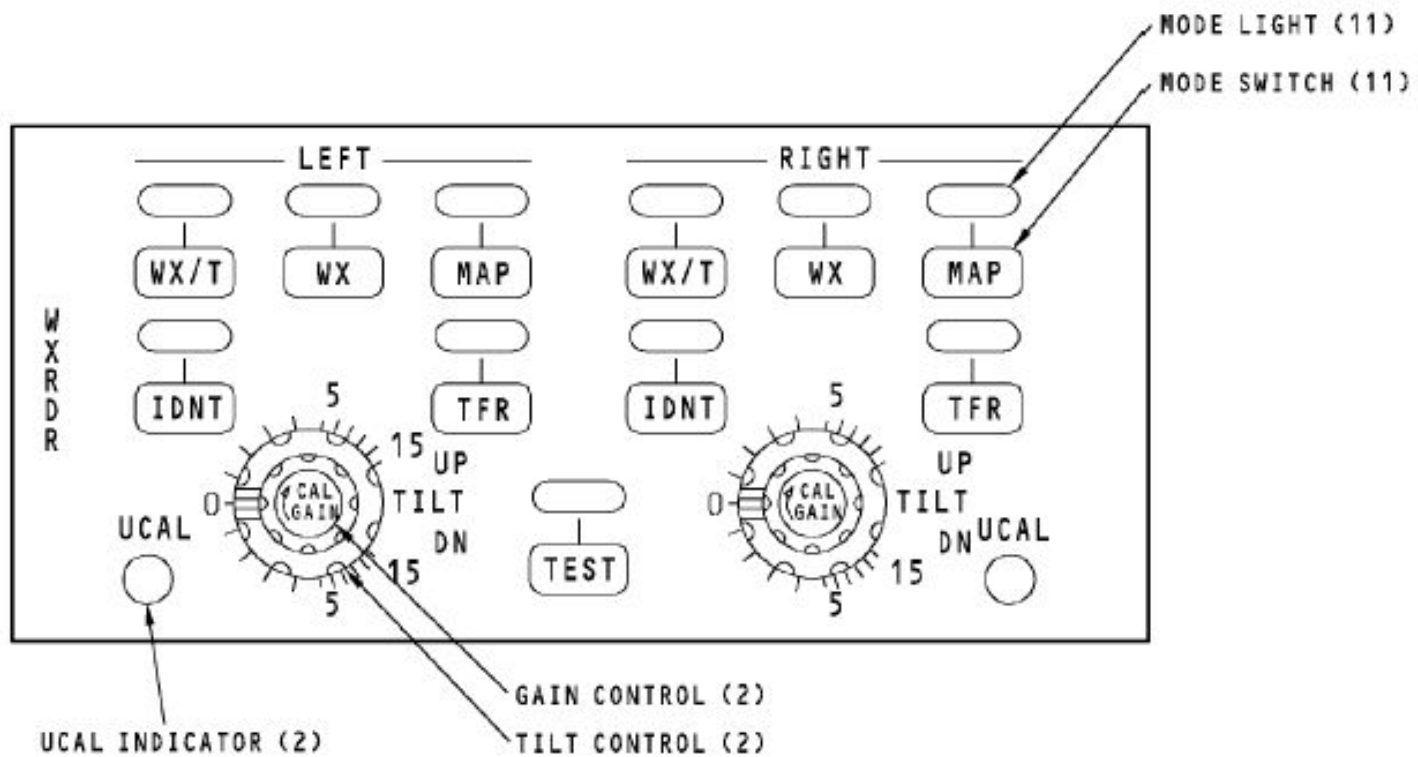

**WXR SYSTEM - CONTROL PANEL**