

Agenda

- Vision general of diagnosis
- Solenoid Valve Monitoring of CR- & U-System
- Outcomes of the Short Circuits
- Solenoid Valve Monitoring Shut Off
- Application procedure
- Actual platform application
- Peculiarity 8 Cylinder software with multiplexer



Agenda

- **Vision general of diagnosis**
 - Functional diagnosis requirements
 - Diagnosis requirements
 - Overview of detectable errors by diagnosis

- Solenoid Valve Monitoring of CR- & U-System
- Outcomes of the Short Circuits
- Solenoid Valve Monitoring Shut Off
- Application procedure
- Actual platform application
- Peculiarity 8 Cylinder software with multiplexer

Functional Diagnosis Requirements

- The objective of injector diagnosis is the detection and classification of errors which can occur while supplying current to an injector as well as the introduction of a desired substitute reaction in the error characteristic.
- **Personal protection:** Prevention of missed injections or wrong injection quantity which can generate undesired engine torque. Occurrence of such errors must always lead to immediate injection Shut Off.
- **Engine and component protection:** Prevention of missed injections or wrong injection quantity, which can damage the engine during combustion. In this case the Common Rail System is significantly more critical than the UI System. This is because in the rail, a sufficiently high diesel pressure is always available for the injectors at any point of time.
- **Availability:** Ensuring the maximum possible availability in the case of an error through defined bank Shut Off or cylinder Shut Off.
- **Exhaust gas:** Prevention of an uncontrolled increase in the emission of toxic substances.
- **OBD:** Supply the ECU-diagnosis management with information about injector diagnosis status to fulfill OBD legislation.
- **Service:** Providing error information, as detailed as possible, for service in order to ensure efficient and cost- effective repair.



Diagnosis Requirements

- ▣ **Robust diagnosis** – Reaction to every error: Even in the case of an error which occurs but cannot be classified as a known error, a detection has to be always carried out and it has to be at least classified as unknown bank/cylinder error. As a result, the applied error reaction is then activated and a dangerous situation can be avoided
- ▣ **No detection of inexistence errors**
- ▣ **Applicable Cylinder Shut Off**
- ▣ **Applicable Bank Shut Off**
- ▣ **Applicable Test Injections**



Overview of detectable errors by diagnosis (1)

- Open Circuit (OC)

- Short Circuit Coil (SCHSLS)

- Short Circuit High Side to Battery (SCHSBA)

- Short Circuit High Side to Ground (SCHSGN)

- Short Circuit Low Side to Battery (SCLSBA)

- Short Circuit Low Side to Ground (SCLSGN)

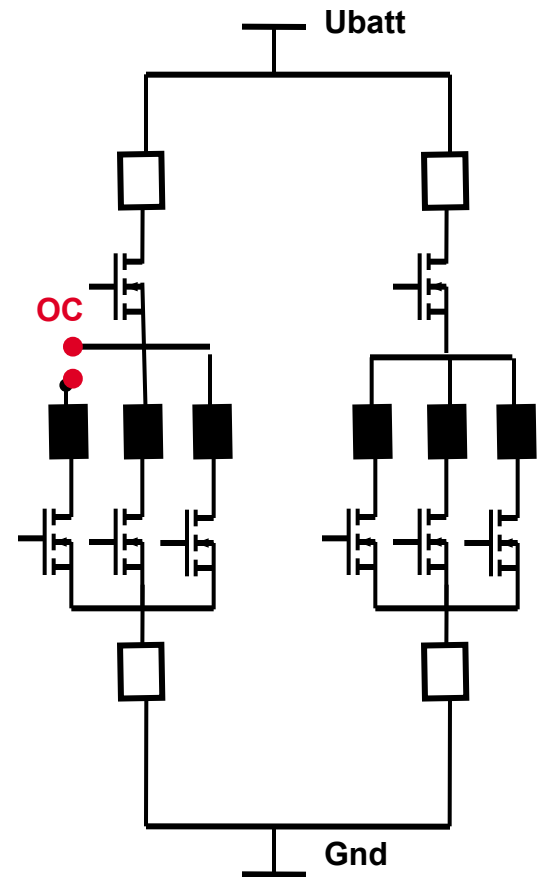

Overview of detectable errors by diagnosis (2)

- Open Circuit (OC)
- **Short Circuit Coil (SCHSLS)**
- Short Circuit High Side to Battery (SCHSBA)
- Short Circuit High Side to Ground (SCHSGN)
- Short Circuit Low Side to Battery (SCLSBA)
- Short Circuit Low Side to Ground (SCLSGN)

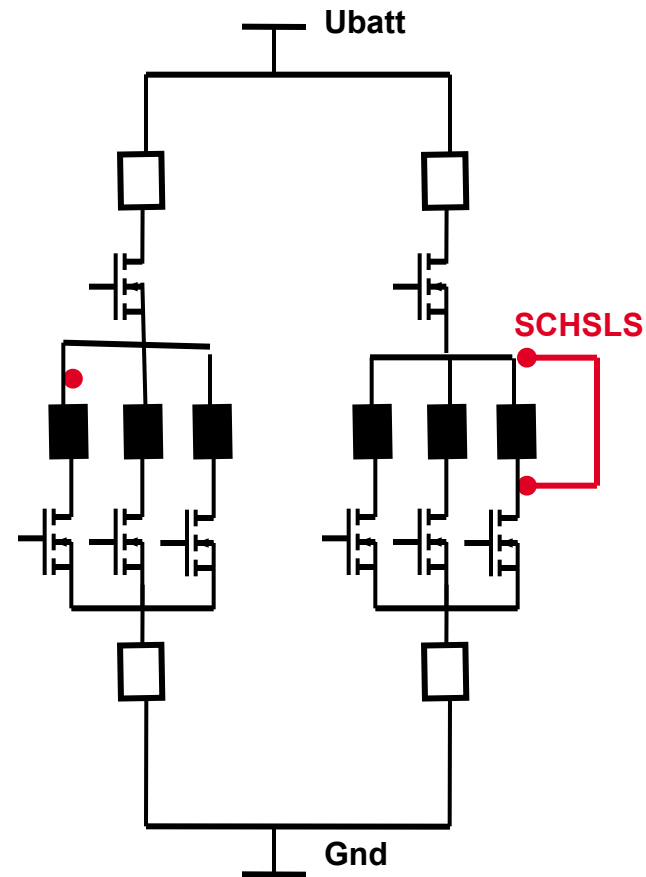

Overview of detectable errors by diagnosis (3)

- Open Circuit (OC)
- Short Circuit Coil (SCHSLS)
- **Short Circuit High Side to Battery (SCHSBA)**
- Short Circuit High Side to Ground (SCHSGN)
- Short Circuit Low Side to Battery (SCLSBA)
- Short Circuit Low Side to Ground (SCLSGN)

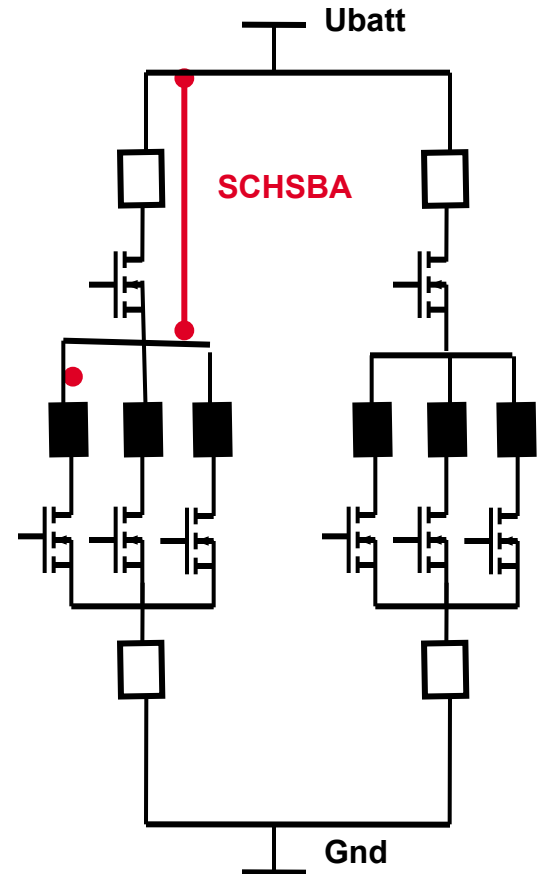

Overview of detectable errors by diagnosis (4)

- Open Circuit (OC)
- Short Circuit Coil (SCHSLS)
- Short Circuit High Side to Battery (SCHSBA)
- **Short Circuit High Side to Ground (SCHSGN)**
- Short Circuit Low Side to Battery (SCLSBA)
- Short Circuit Low Side to Ground (SCLSGN)

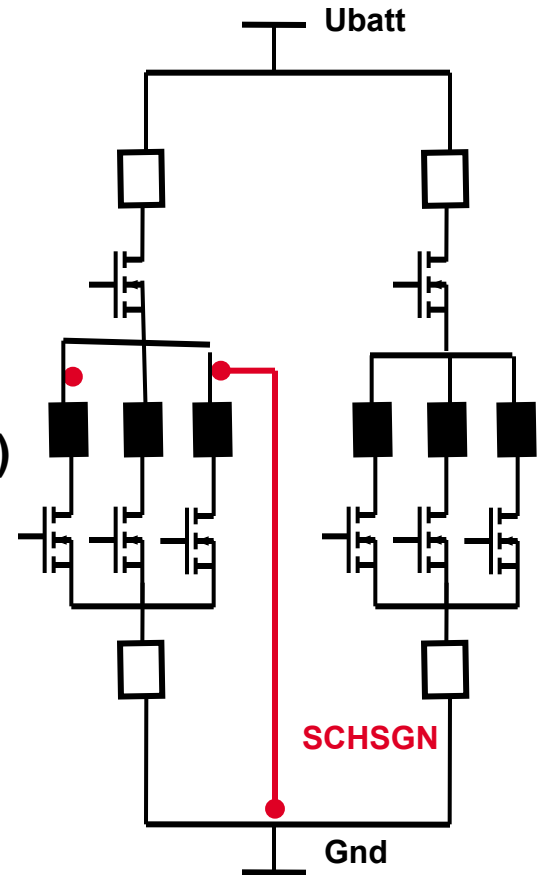

Overview of detectable errors by diagnosis (5)

- Open Circuit (OC)
- Short Circuit Coil (SCHSLS)
- Short Circuit High Side to Battery (SCHSBA)
- Short Circuit High Side to Ground (SCHSGN)
- **Short Circuit Low Side to Battery (SCLSBA)**
- Short Circuit Low Side to Ground (SCLSGN)

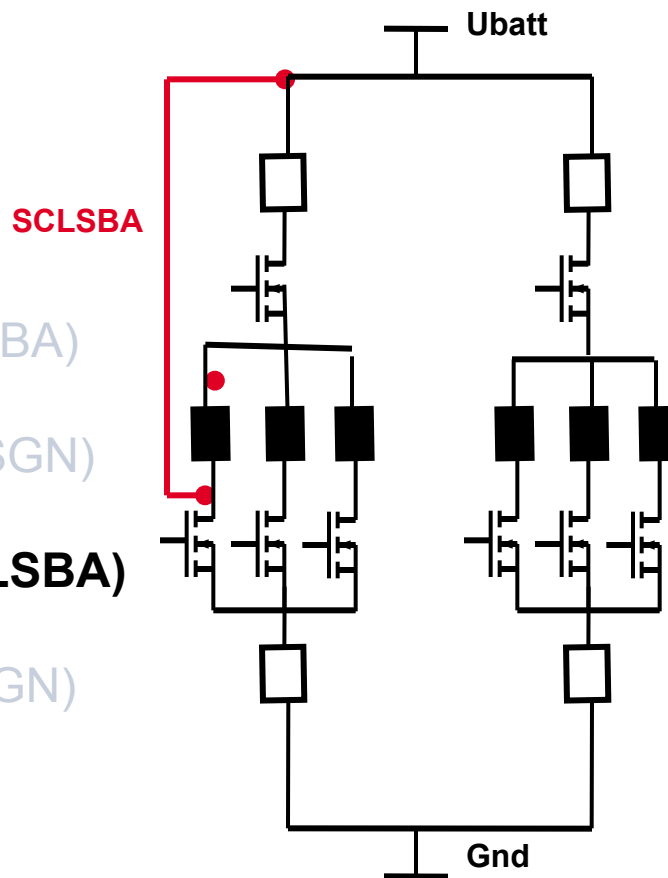

Overview of detectable errors by diagnosis (6)

- Open Circuit (OC)
- Short Circuit Coil (SCHSLS)
- Short Circuit High Side to Battery (SCHSBA)
- Short Circuit High Side to Ground (SCHSGN)
- Short Circuit Low Side to Battery (SCLSBA)
- **Short Circuit Low Side to Ground (SCLSGN)**

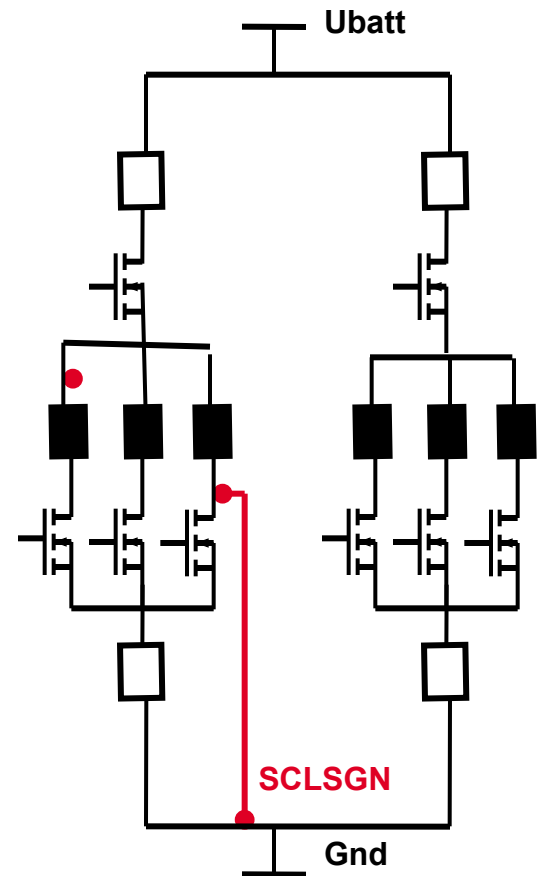

Agenda

- Vision general of diagnosis
- **Solenoid Valve Monitoring of CR- & U-System**
 - Scheduling of the diagnosis
 - Monitoring Overview (InjVlv_Mon)
 - Error messages transferred via SPI
 - Error Pattern
 - Pattern recognition sequence
 - Error Debouncing
 - InjVlv_Mon Labels
 - Peculiarity for CV-System
- Outcomes of the Short Circuits
- Solenoid Valve Monitoring Shut Off
- Application procedure
- Actual platform application
- Peculiarity 8 Cylinder software with multiplexer

Scheduling of the diagnosis

The injector energizing diagnostic function is performed once for each completed motor cycle (each 720° crankshaft). After a completed motor cycle all necessary diagnostic information are available.

Example for 6 Cylinders, 2 Bank System

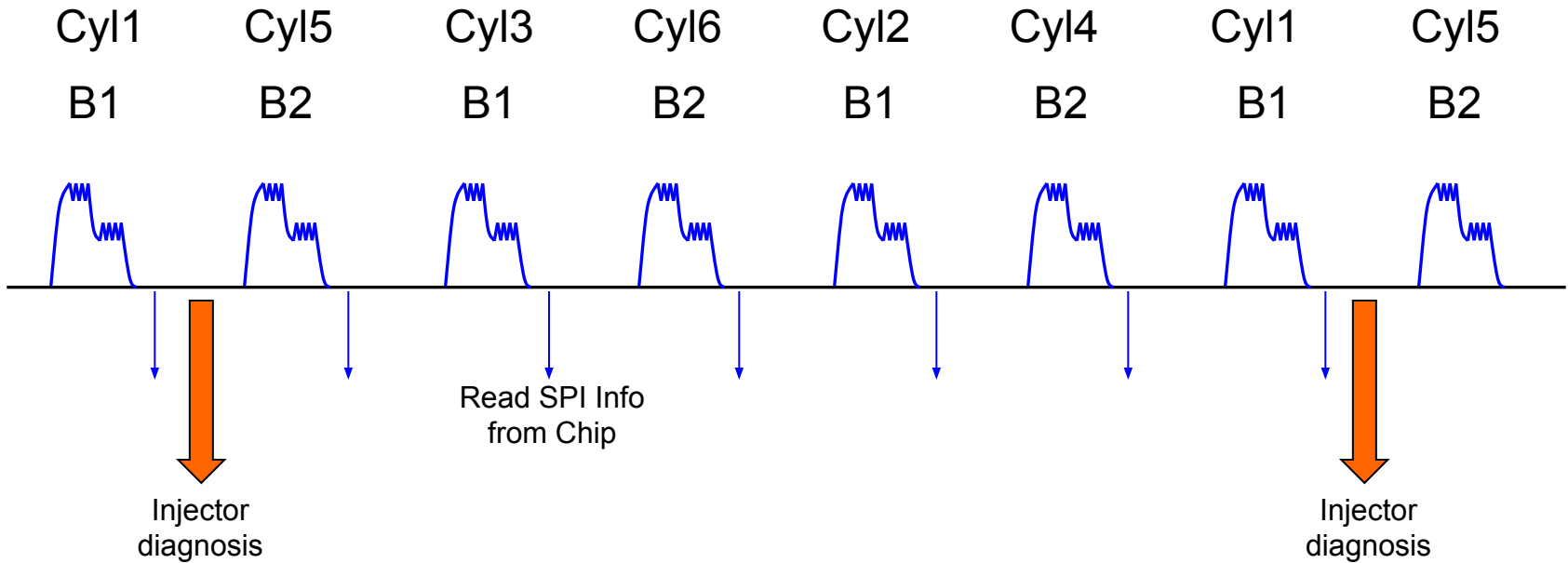

Monitoring Overview (InjVlv_Mon) (1)

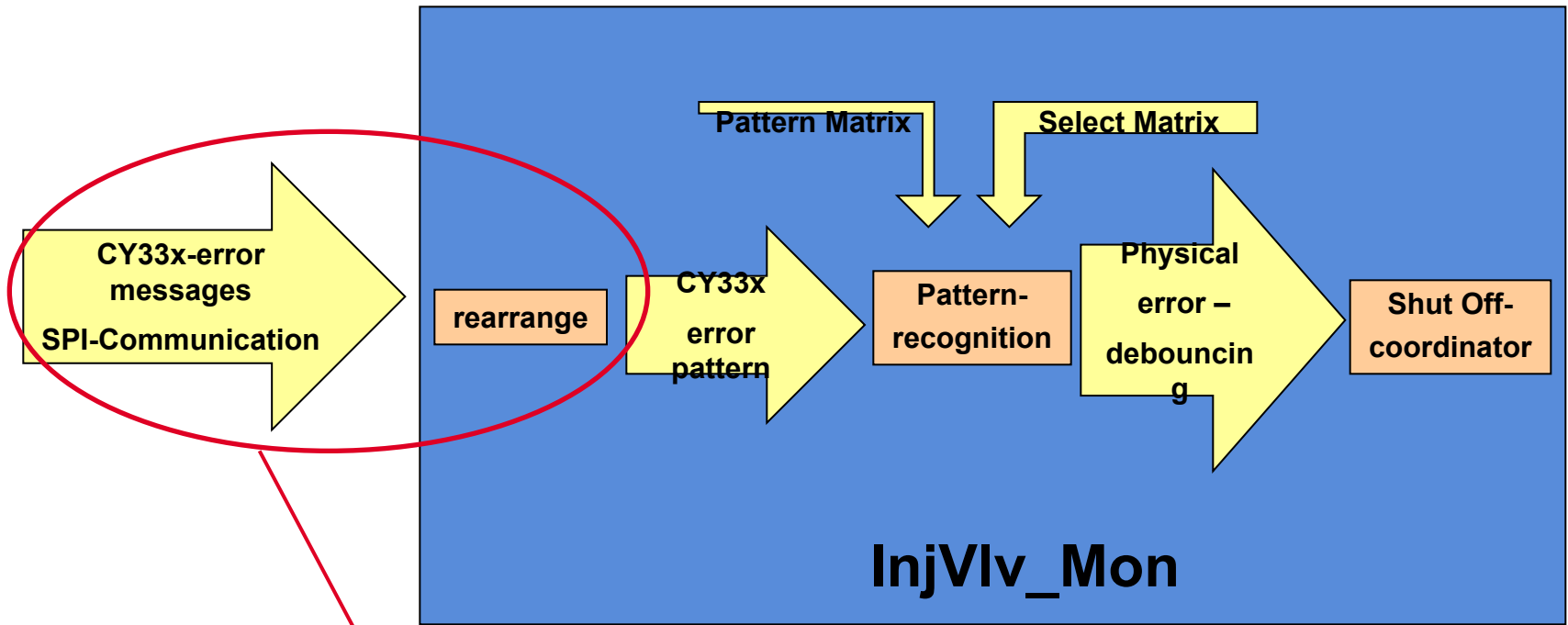

The error messages are transmitted from the power stage component CY33x via SPI to the microcontroller and rearrange to calculate an error pattern.

Monitoring Overview (InjVlv_Mon)(2)

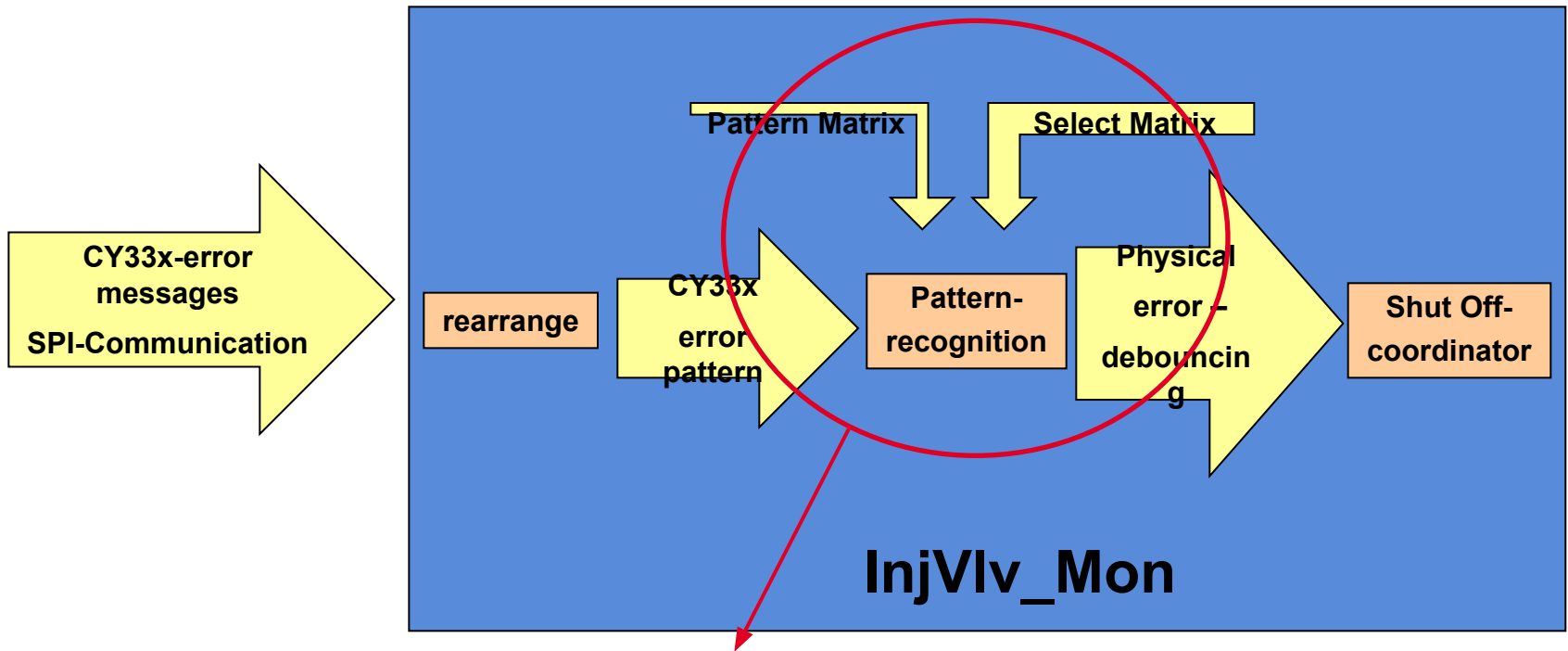

The error pattern is now subjected to a pattern recognition. Logical operations are performed on pattern and select matrix entries to check whether the error pattern matches one of the known physical errors.

Monitoring Overview (InjVlv_Mon) (3)

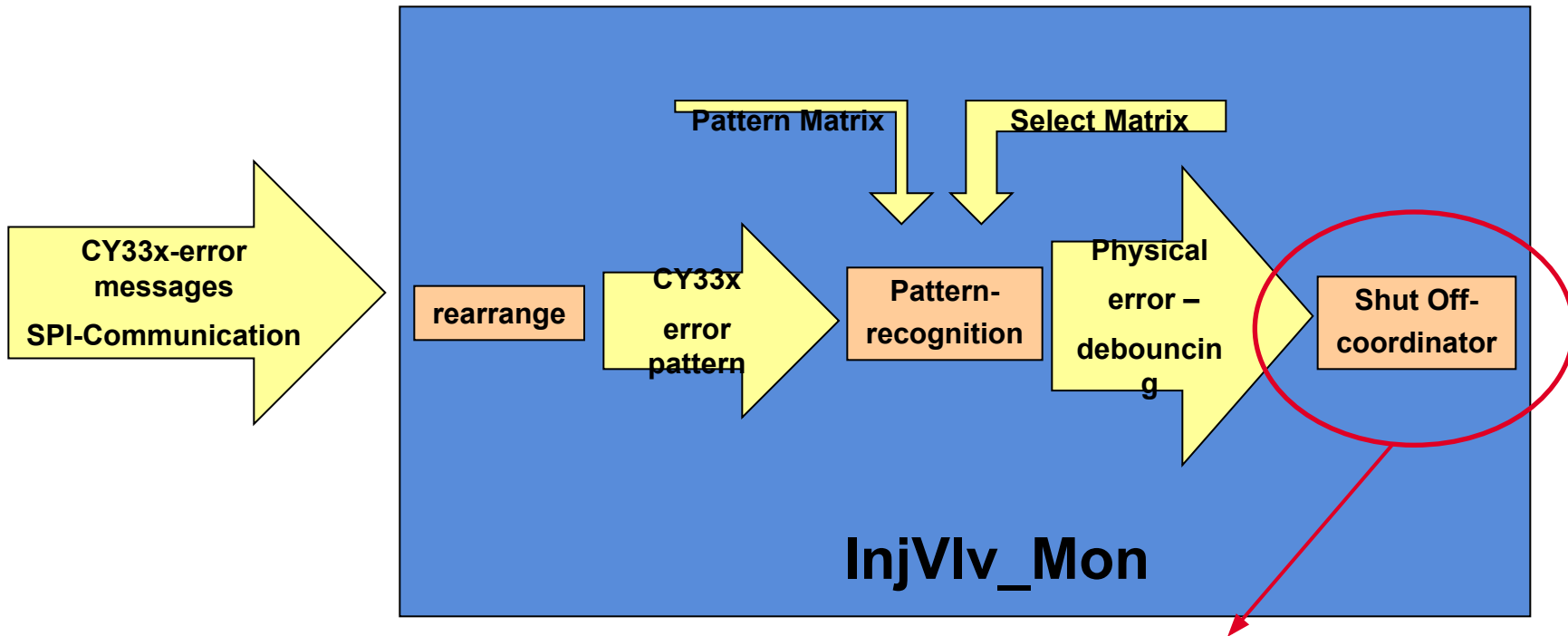

If an error pattern is identified and classified, the system is Shut Off depending on the severity of the error.

Overview of Diagnosis

Error messages transferred via SPI (1)

Example for 6 Cylinders, 2 Bank System

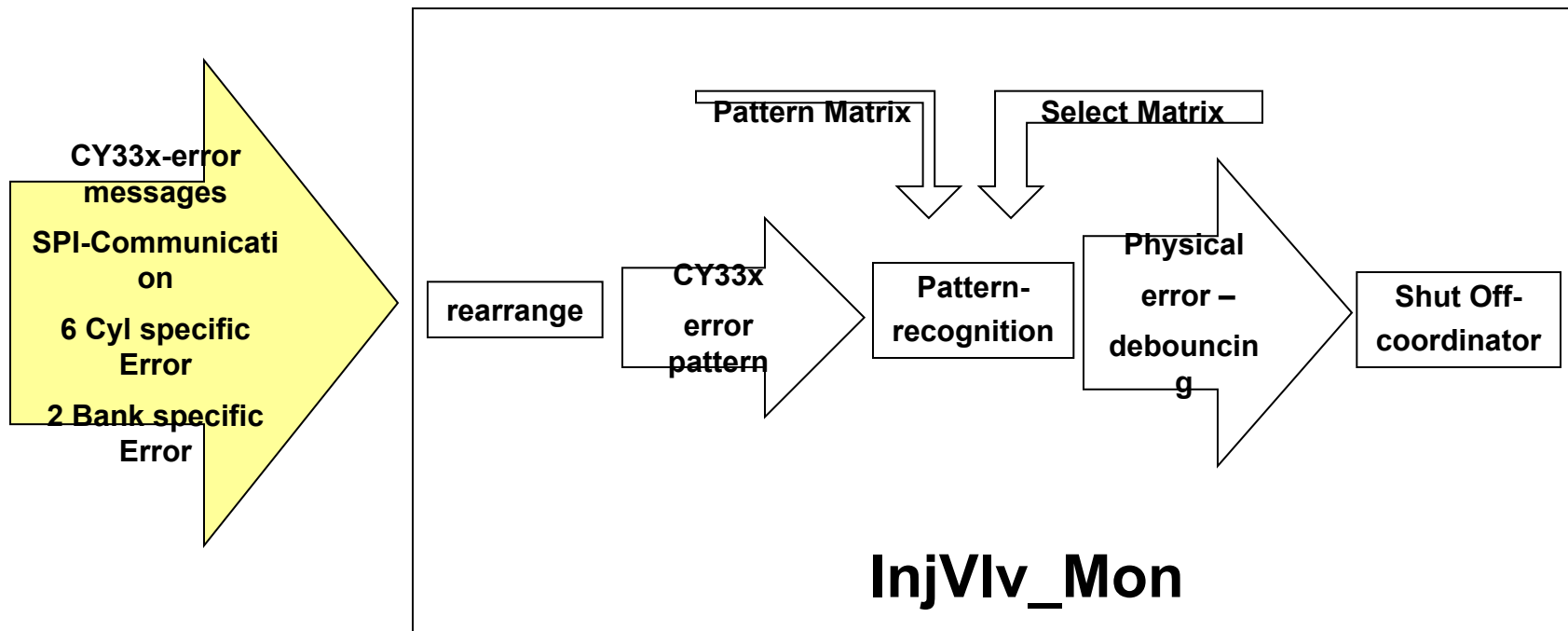

Error messages transferred via SPI (2)

Structure of an internal CY33x cylinder error register

BIT	CY33x ERROR
0	Maximal current in HS-Switch
1	Maximal current in LS-Switch
2	Differential current (HS-LS)
3	No load detected (open circuit)
4	Fast decay check failure
5	-
6	Current level error
7	Injection Finished

This information is displayed in the measuring point: **InjVlv_stErrCyl\$ _mp**

InjVlv_stErrCyl\$ _mp.Bit0...7 = 1 -> The event took place

 = 0 -> Default value

Error messages transferred via SPI (3)

InjVlv_stErrCyl\$ _mp.Bit0 - Maximal current in HS-Switch

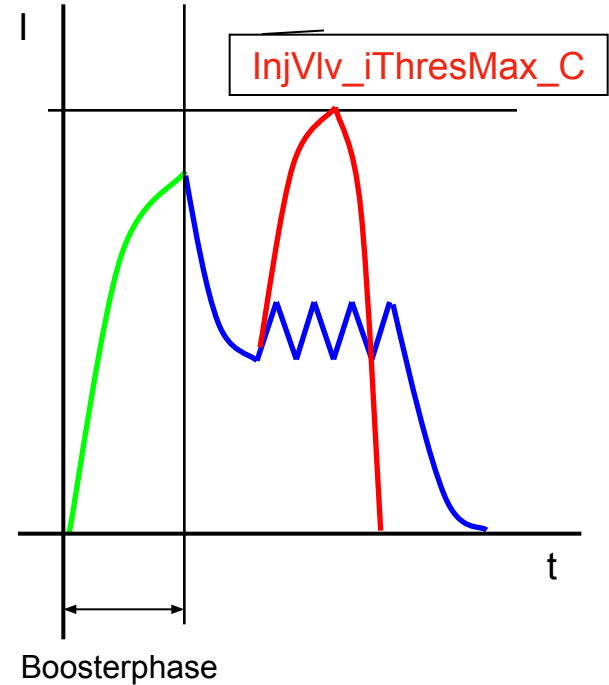
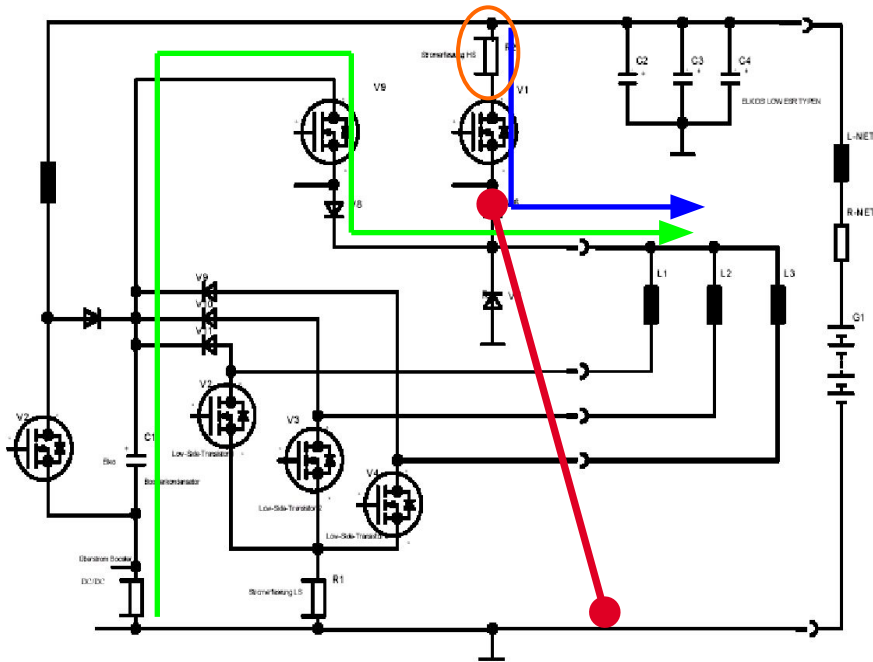

InjVlv_iThresMax_C (Threshold for over current detection of injection power stage) ≈ 32.2 A

Overview of Diagnosis

Error messages transferred via SPI (4)

InjVlv_stErrCyl\$ _mp.Bit1 - Maximal current in LS-Switch

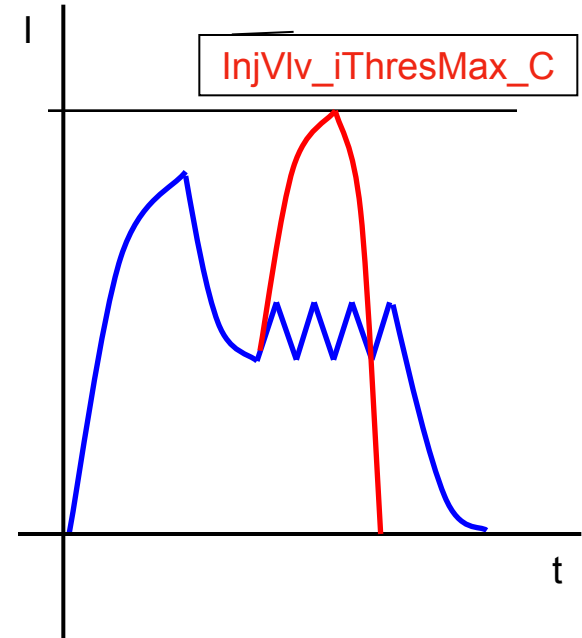
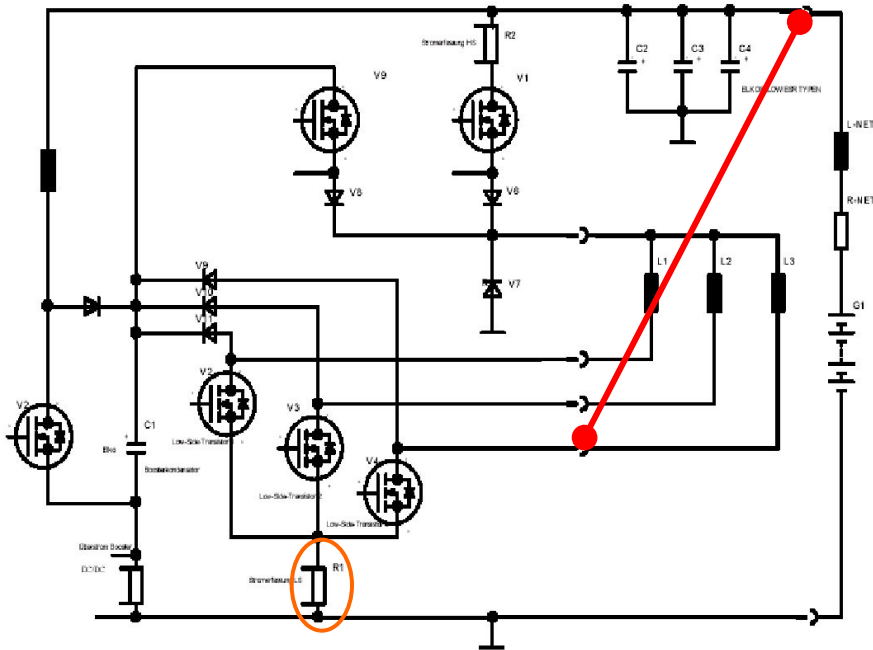

InjVlv_iThresMax_C (Threshold for over current detection of injection power stage) ≈ 32.2 A

Error messages transferred via SPI (5)

InjVlv_stErrCyl\$ _mp.Bit2 - Differential current (HS-LS)

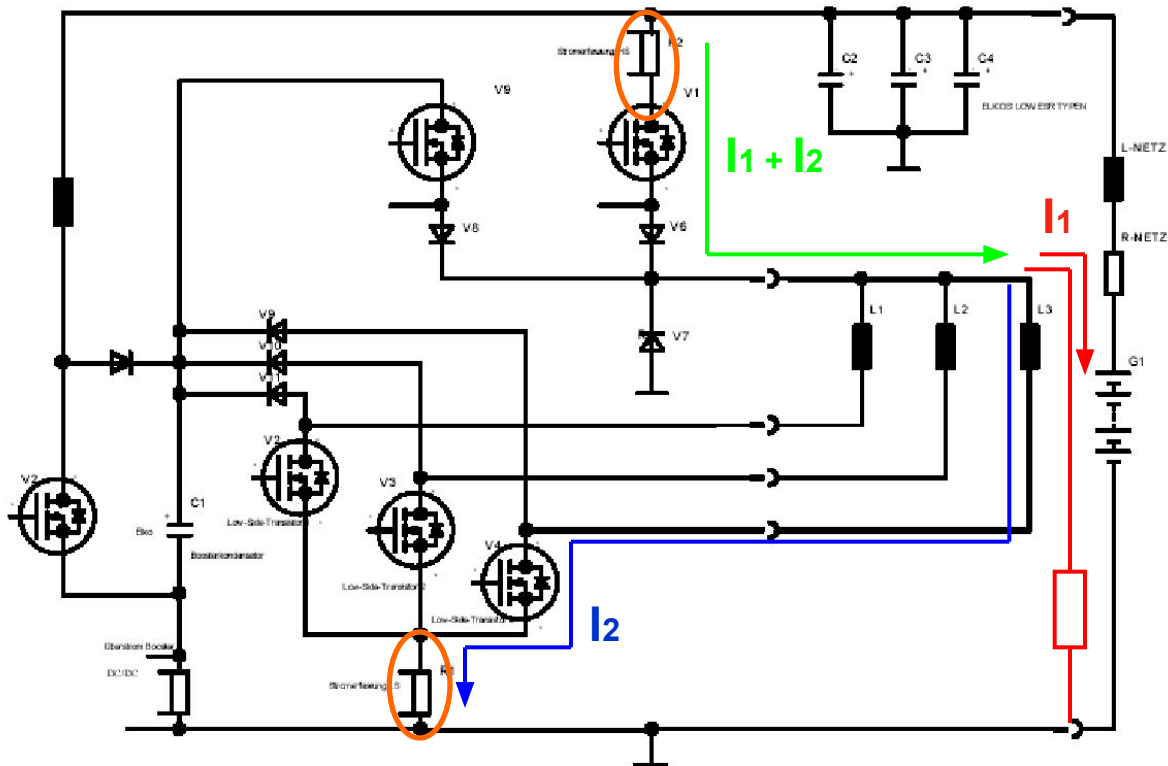

InjVlv_stRegDmsk_C - To configure which current level should be use to detect a current difference between HS and LS

Error messages transferred via SPI (6)

InjVlv_stErrCyl\$ _mp.Bit3 - No load detected (open circuit)

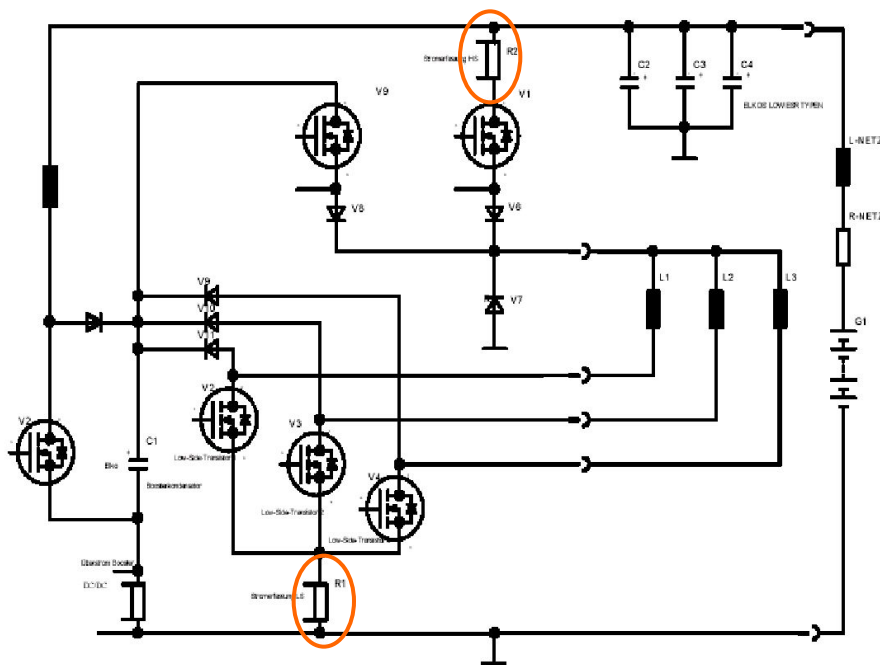

$$I_{min} = U_{min} / (R_s \times (R_R/R_V)) = 2,66 \text{ A}$$

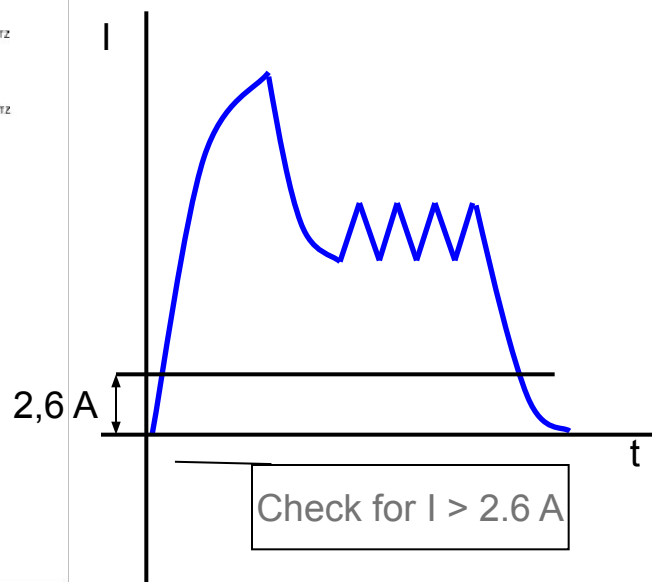

The current in HS-Shunt and LS-Shunt must exceed I_{min} level during energizing time

Error messages transferred via SPI (7)

InjVlv_stErrCyl\$ _mp.Bit4 – Fast decay check failure (C-System)

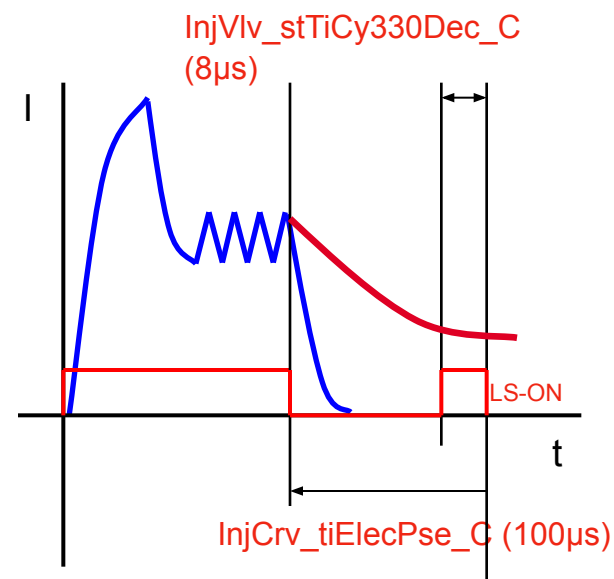
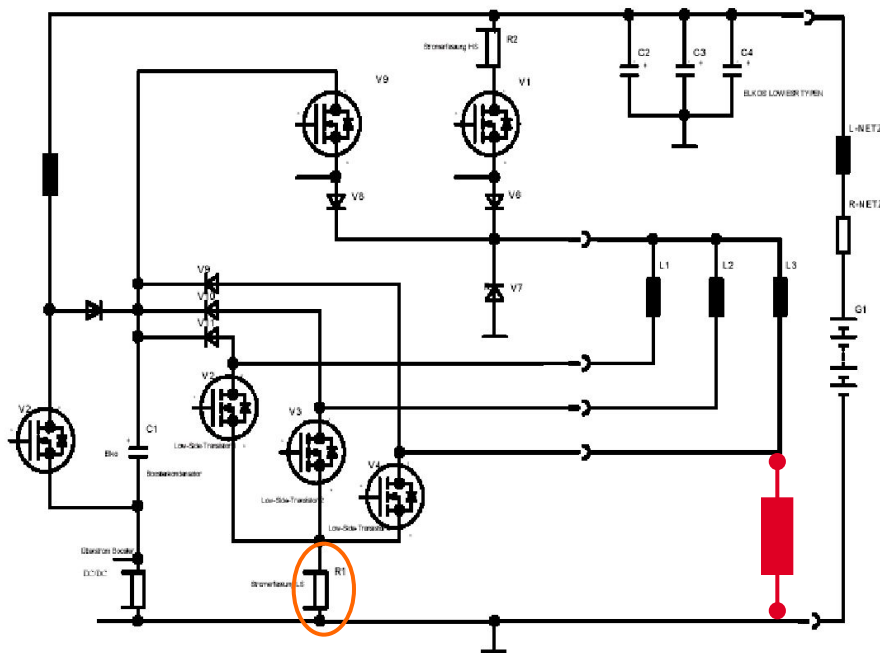

InjVlv_stTiDelAftFastIDec_C – Time limit for measuring duration of fast decay

InjVlv_stTiFastIDecErrMax_C – Max. allowed time for fast current decay

Overview of Diagnosis

Error messages transferred via SPI(8)

InjVlv_stErrCyl\$ _mp.Bit4 – Fast decay check failure (C-System)

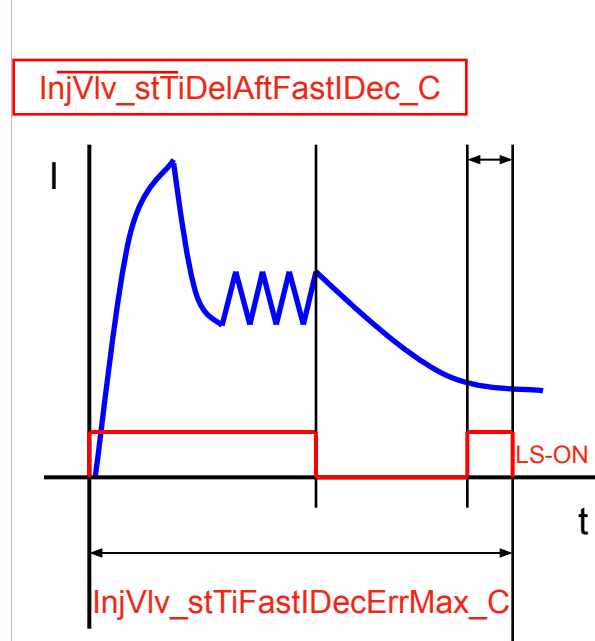
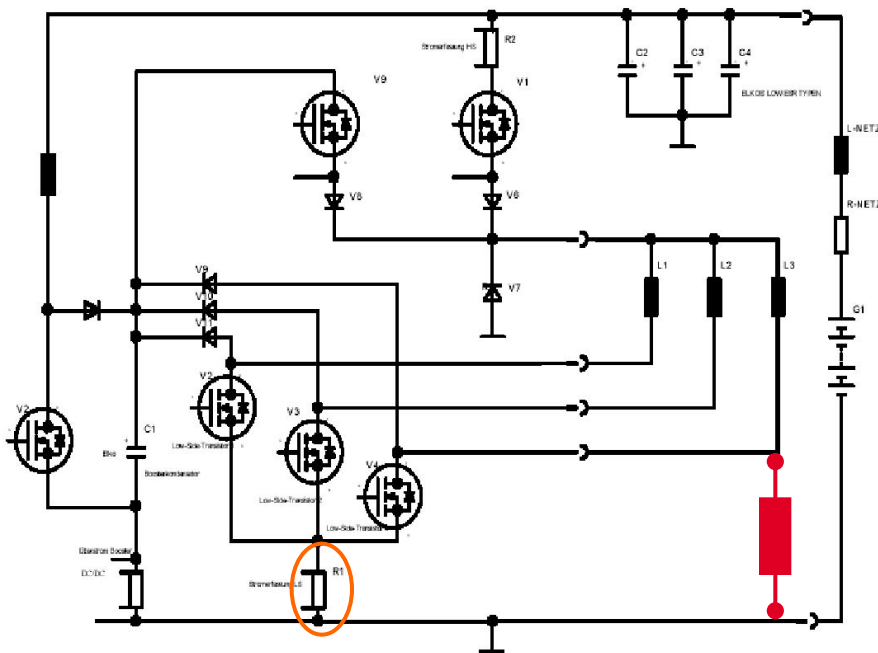

Error messages transferred via SPI (9)

InjVlv_stErrCyl\$ _mp.Bit6 – Current Level Error

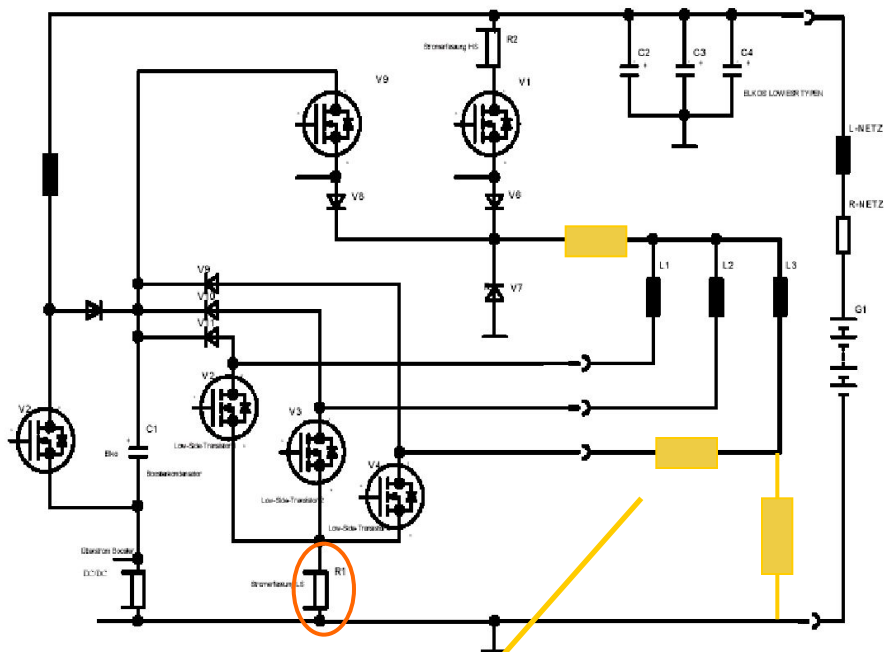

False wiring harness

Low Battery

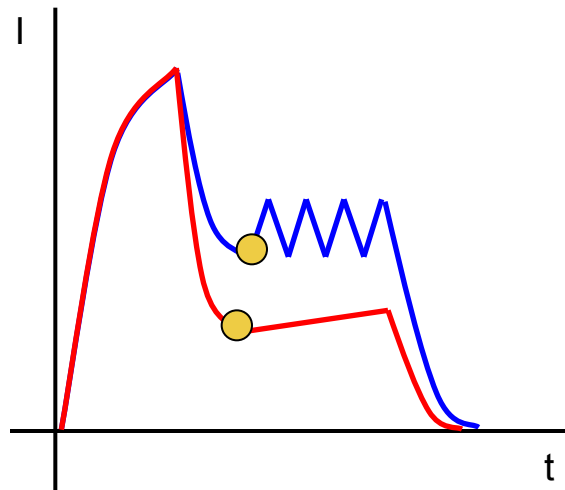

SCLSGN



Error messages transferred via SPI (10)

InjVlv_stErrCyl\$_mp.Bit7 – Injection Finished

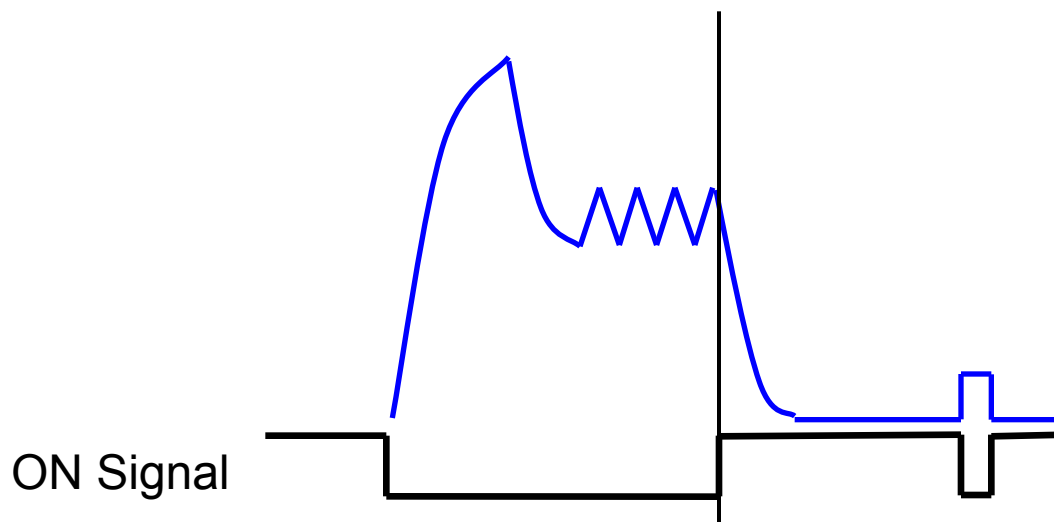

Information that CY33x internal state machine (without any error) performed a complete energizing cycle.

This Bit can only be set if FastDecayCheck feature is enabled. The injection finished bit is set when the pre-instruction FastDecayCheck is finished.

Error messages transferred via SPI (11)

Structure of an internal CY33x bank error register

BIT	CY33x ERROR
0	Booster voltage Over-range error
1	Booster voltage Under-range Error
2	Booster current-Low Error
3	Booster current-High Error
4	Booster Time-out Error
5	-
6	LS current Error
7	ON signal time out

This information is displayed in the measuring point: **InjVlv_stErrBnk\$_mp**

InjVlv_stErrBnk\$_mp.Bit0...7 = 1 -> The event took place

= 0 -> Default value

Error messages transferred via SPI (12)

InjVlv_stErrBnk\$ _mp.Bit0 - Booster voltage Over-range error

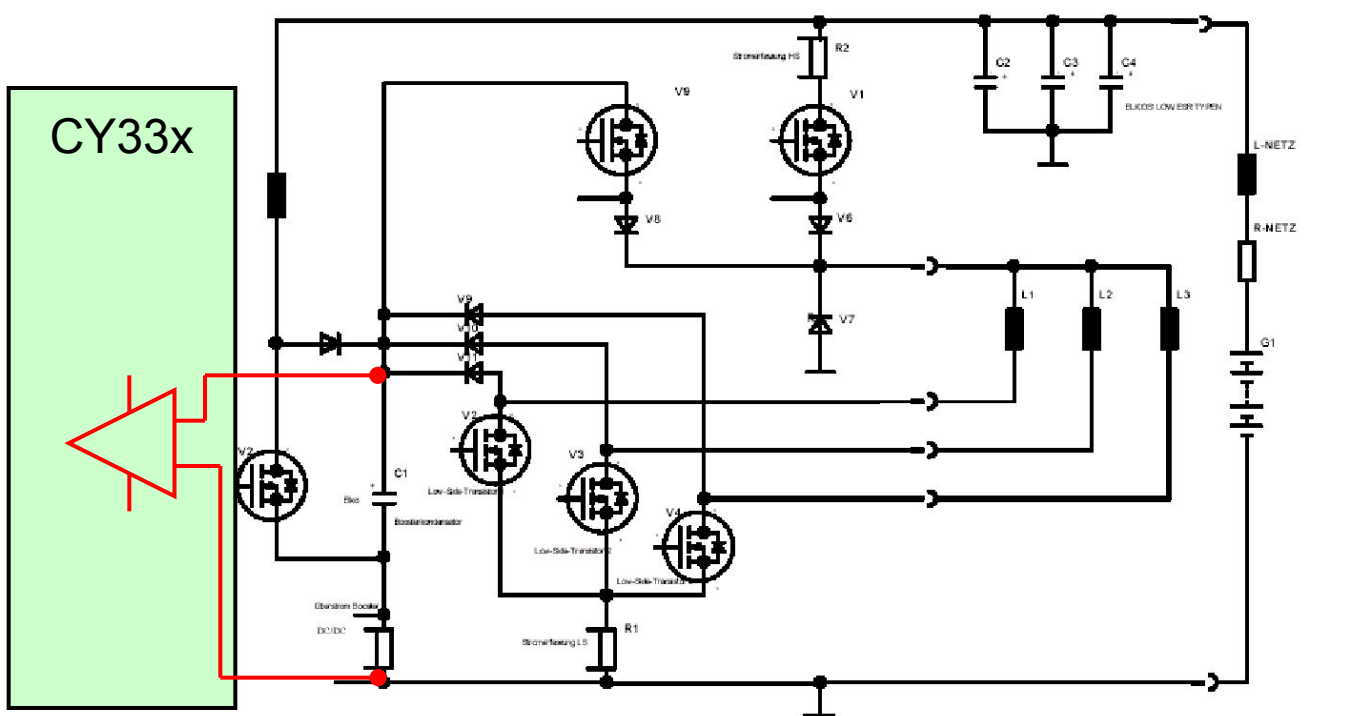

InjVlv_uCMax_C (Threshold for booster over voltage of injector power stage) \approx 61,9 V

Error messages transferred via SPI (13)

InjVlv_stErrBnk\$ _mp.Bit1 - Booster voltage Under-range error

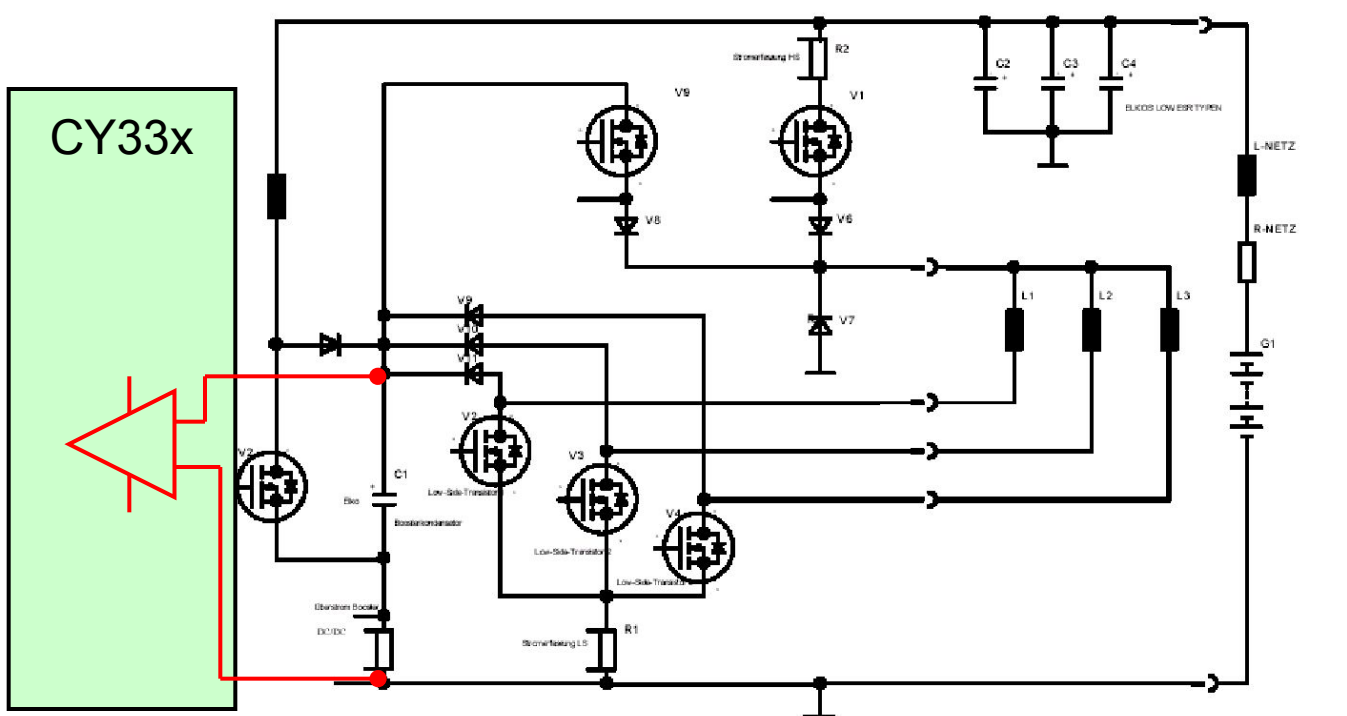

InjVlv_uCMin_C (Booster voltage low indicator of injection power stage) \approx 35-42 V

Error messages transferred via SPI (14)

InjVlv_stErrBnk\$ _mp.Bit2 - Booster current-Low Error

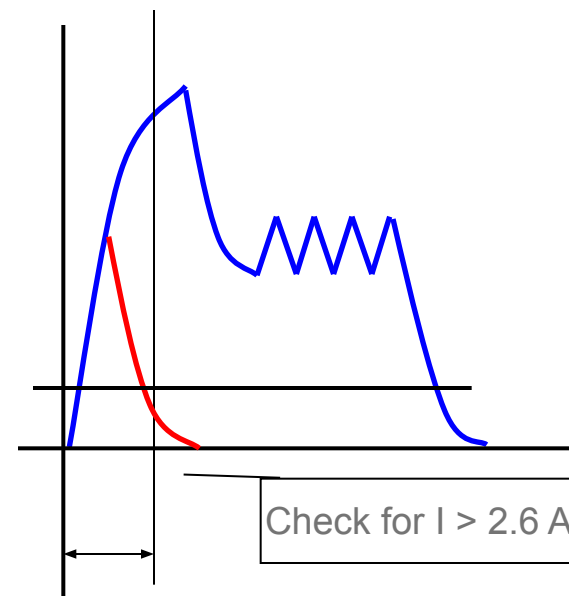
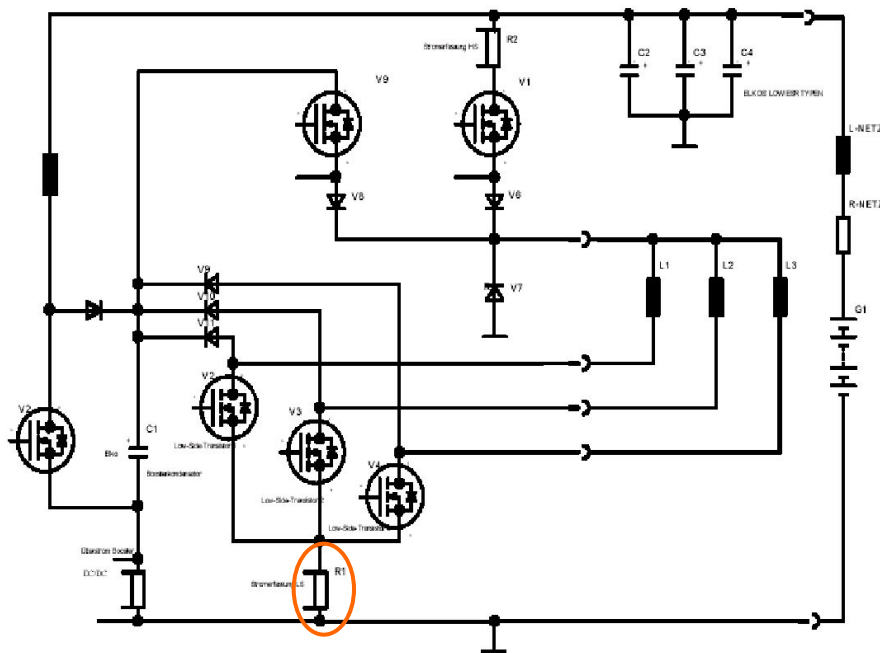

InjVlv_stTiBstErrMin_C

InjVlv_stTiBstErrMin_C (I must exceed I_{min} level after this time) $\approx 64 \mu\text{s}$

Error messages transferred via SPI (15)

InjVlv_stErrBnk\$ _mp.Bit3 - Booster current-High Error

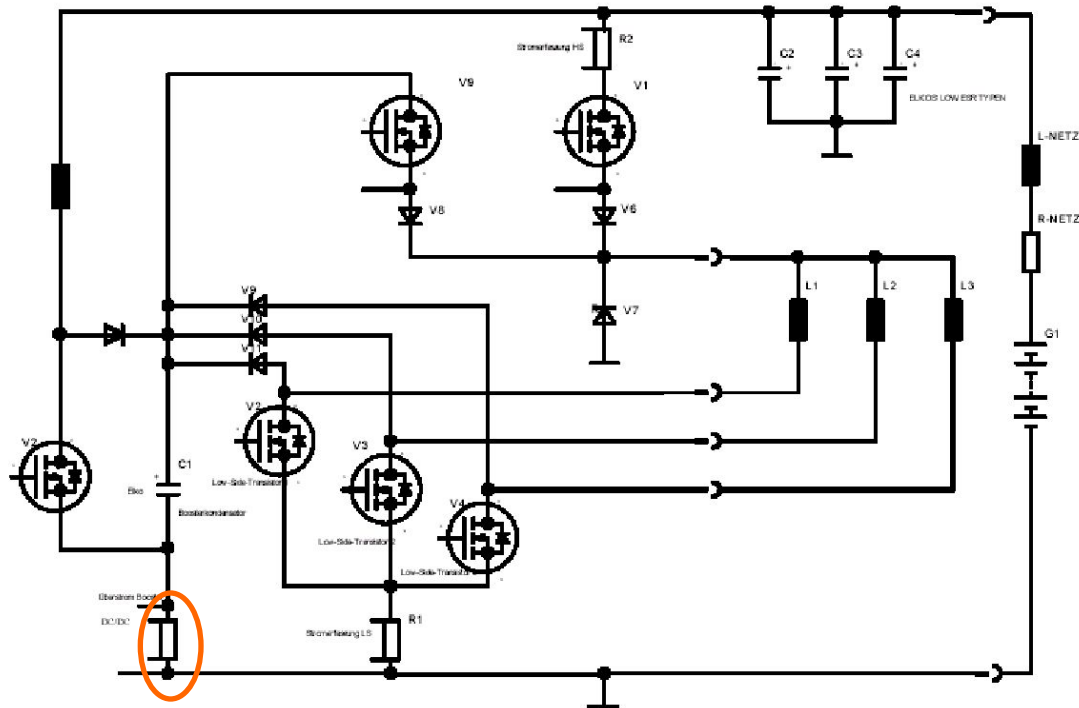

Applied to 66.6 A at EDC7UC31 (bigger than overlapping injections 2 x 25 A)

Error messages transferred via SPI (16)

InjVlv_stErrBnk\$ _mp.Bit4 - Booster Time-out Error

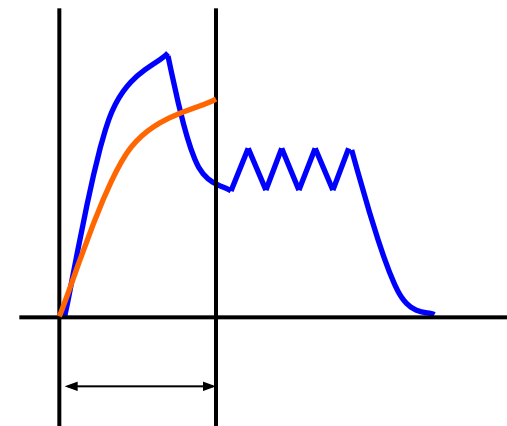
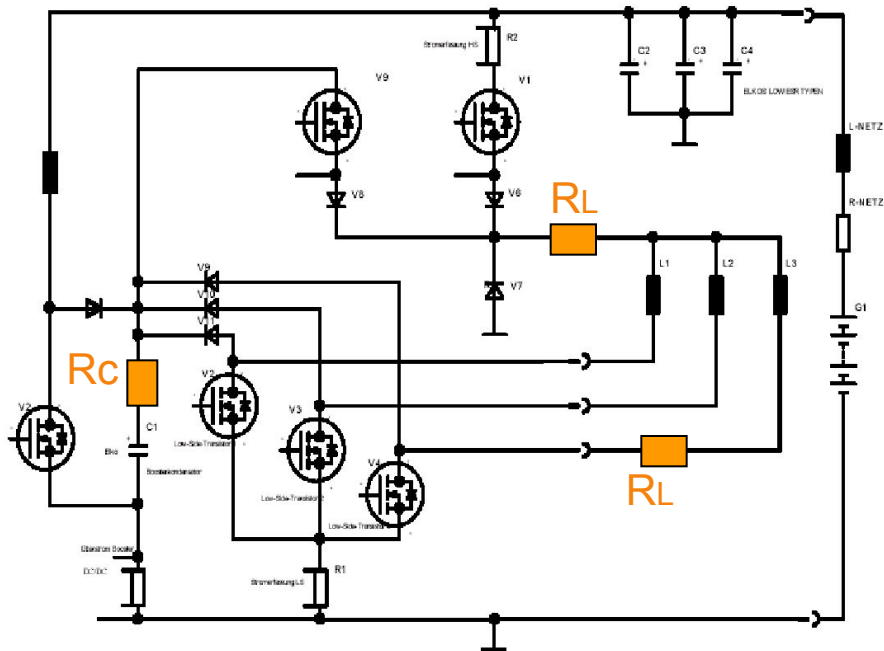

InjVlv_stTiBstErrMax_C

After the time InjVlv_stTiBstErrMax_C the current InjVlv_iLvLo1_C is not reached.

- Old SG ➔ ↑ Rc
- ↓ Temp ➔ ↑ Rc
- ↑ Temp ➔ ↑ RL

Error messages transferred via SPI (17)

InjVlv_stErrBnk\$ _mp.Bit6 – LS current Error

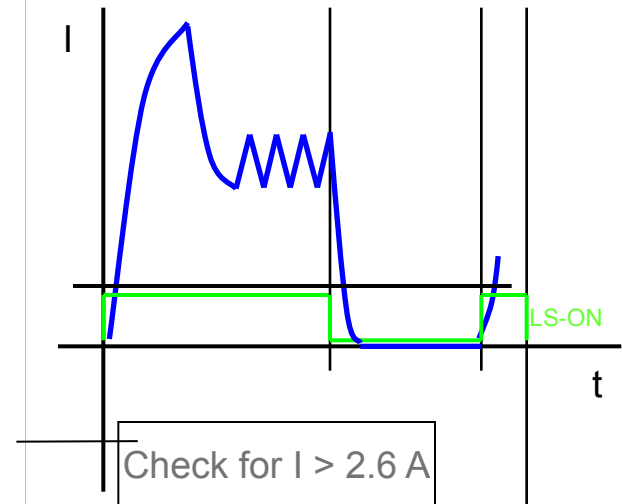
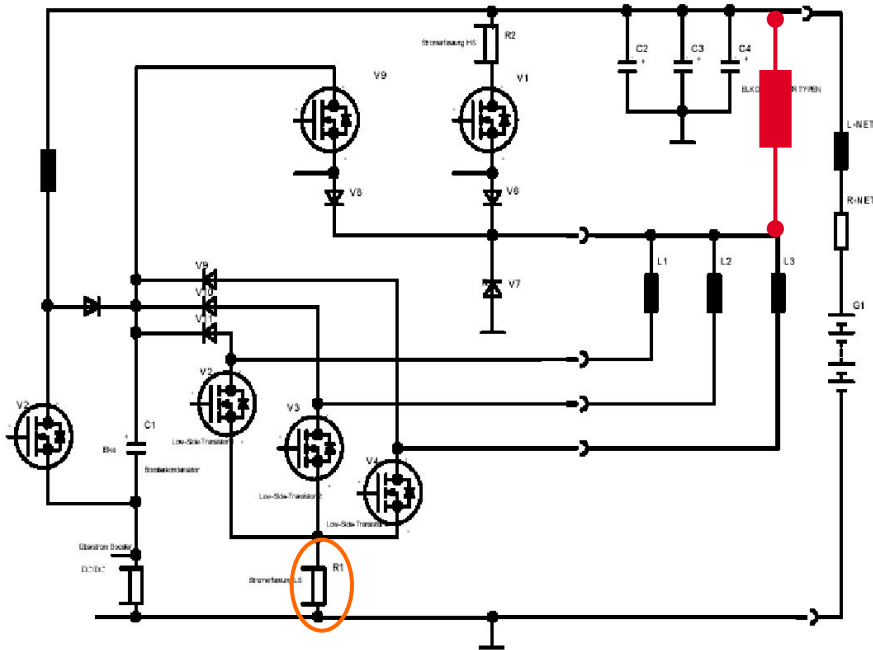

Error messages transferred via SPI (18)

InjVlv_stErrBnk\$_mp.Bit7 – ON Signal time out

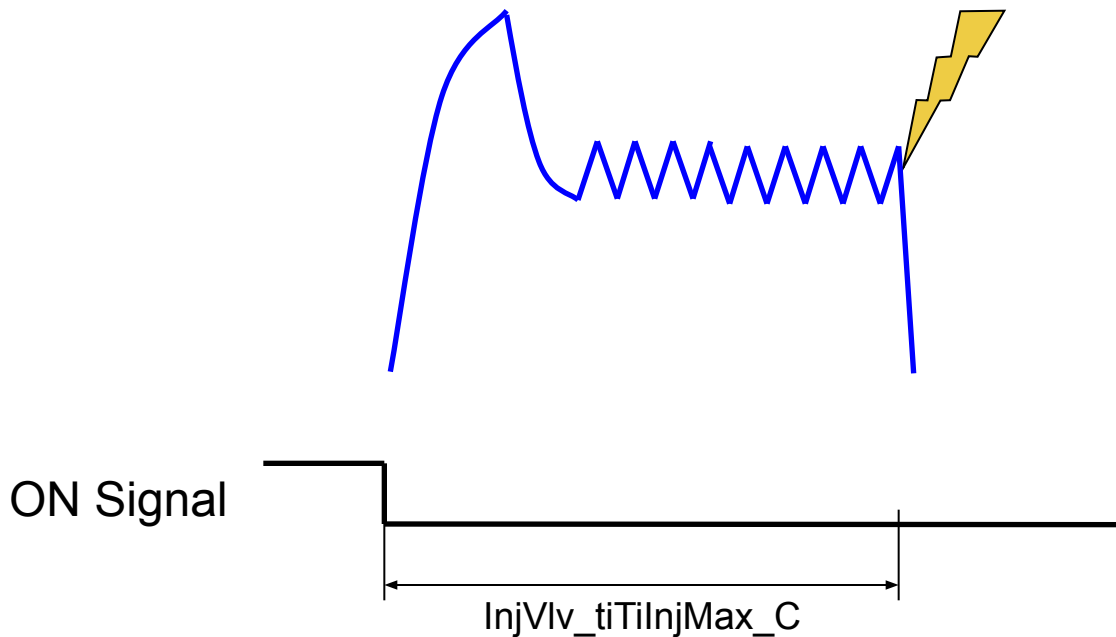

InjVlv_tiTiInjMax_C (Max. allowed time for active ON-signal)

Overview of Diagnosis

Error pattern (1)

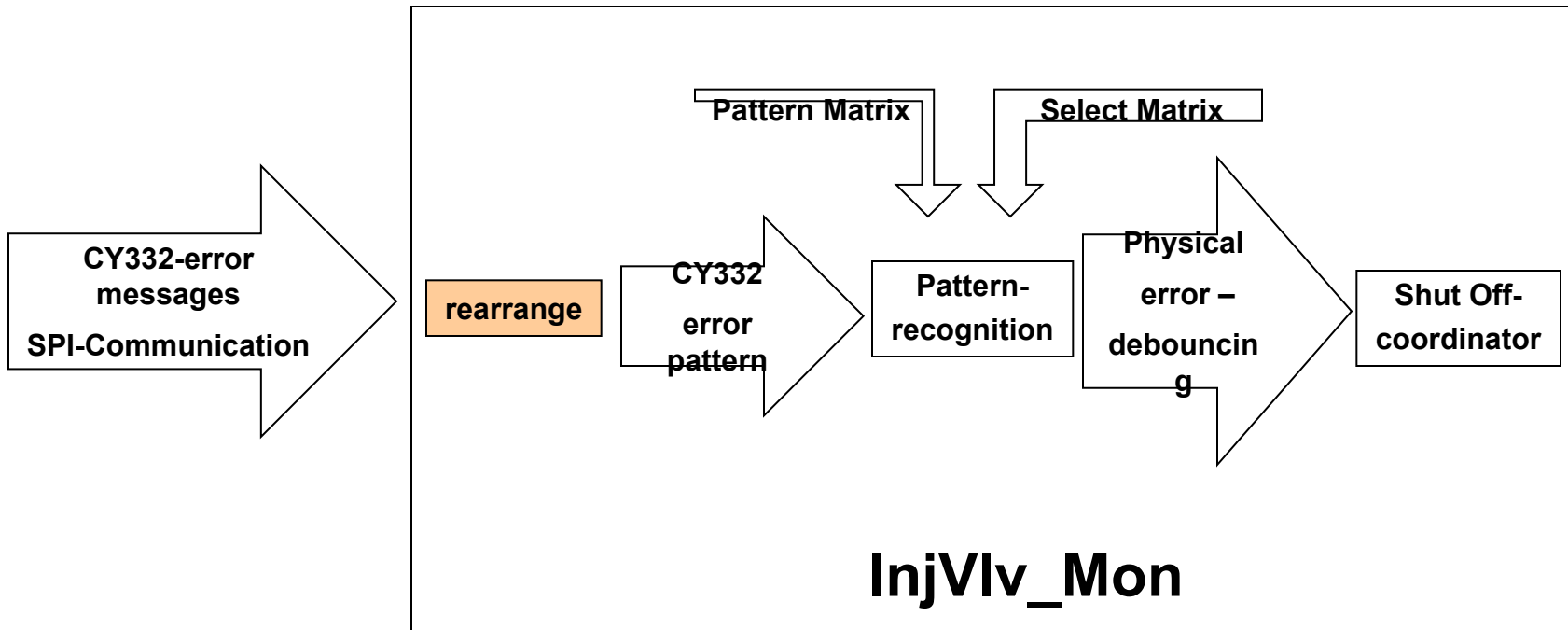

Overview of Diagnosis

Error pattern (2)

A CY33x error pattern is rearranged for each cylinder.

The following figure shows this arrangement for cylinder 1 in a 2 Bank system (Cylinders 1, 2 and 3 in Bank 1)

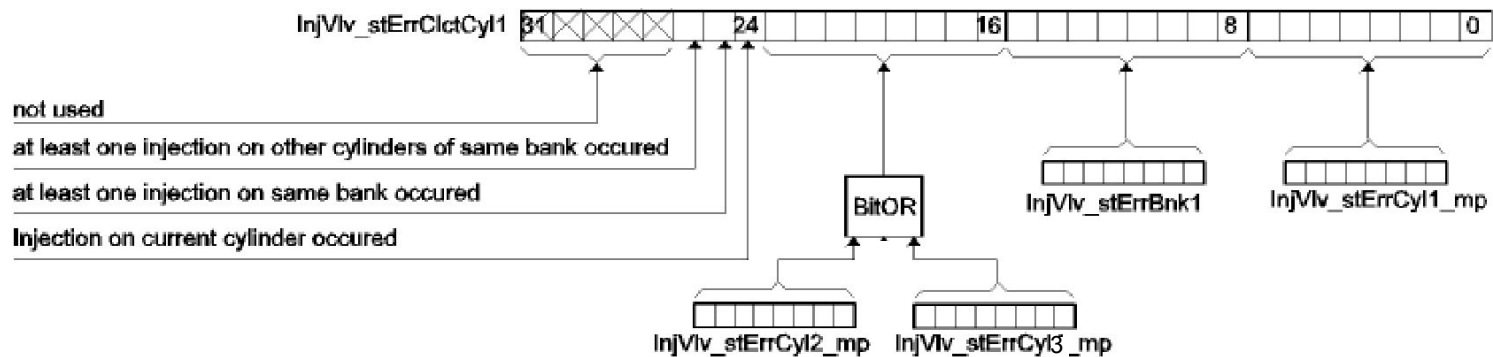

Pattern recognition sequence (1)

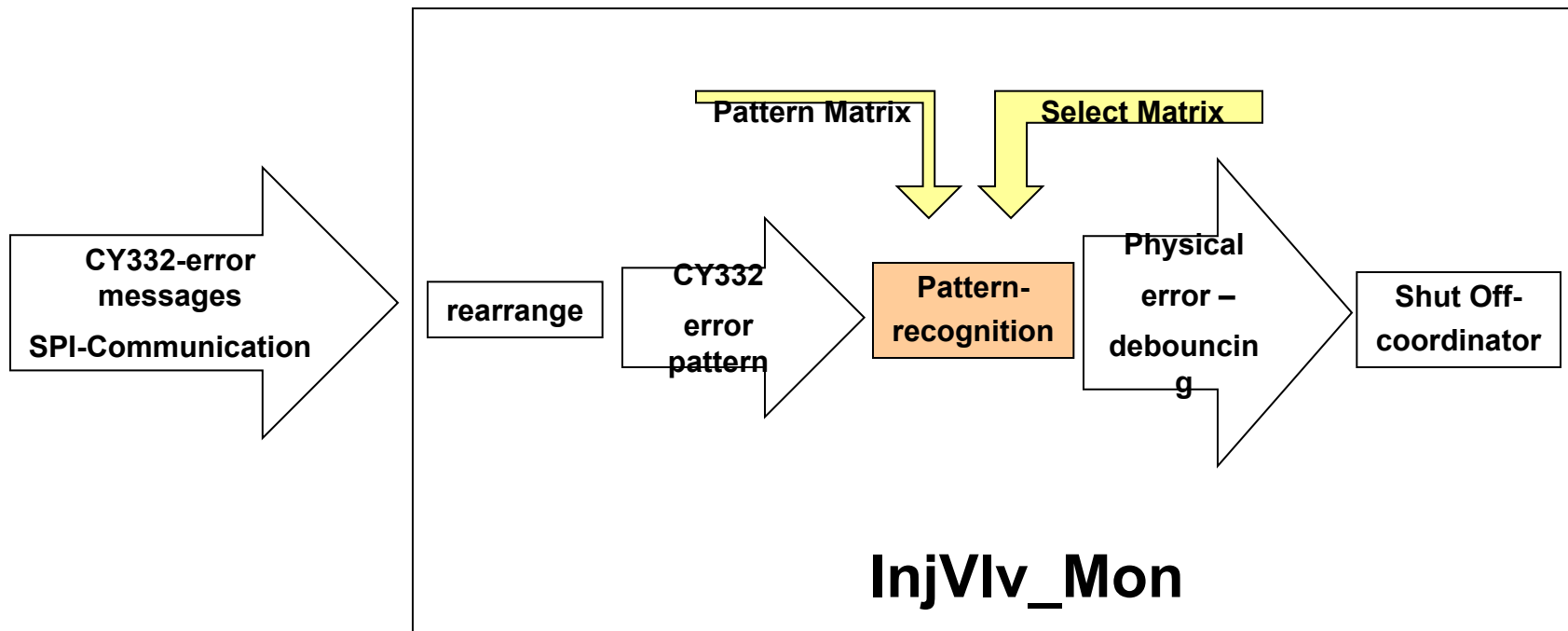

Pattern recognition sequence (2)

Structure of the pattern matrix

- The pattern matrix `InjVlv_stErrMskPattern_C` is composed of 32 entries which are each 32 bits wide.
- Error patterns which result from physical errors in the injector cables can be applied by the pattern matrix. **An entry in the matrix describes a pattern of a physical error.**
- The allocation of bits 0 to 26 to individual matrix entries refers to the same bits in the CY33x error pattern (described in the Error pattern).
- The most significant bits in each matrix entry indicate the physical error to which the pattern belongs. Bit 27 indicates whether the pattern identifies a bank error or a cylinder error. Bits 28 and 29 determine the error type and the error bit for the error path. Bits 30 and 31 determine which of both bank and cylinder error paths (A or B) is allocated to this pattern entry.
- Entries 0 and 1 are used for errors that cannot be classified. Entries 2 to 31 can be used for errors that can be classified.
- Since entries 0 and 1 are used for unclassified errors, bits 0 to 26 are applied to 0.

Pattern recognition sequence (3)

Structure of the pattern matrix

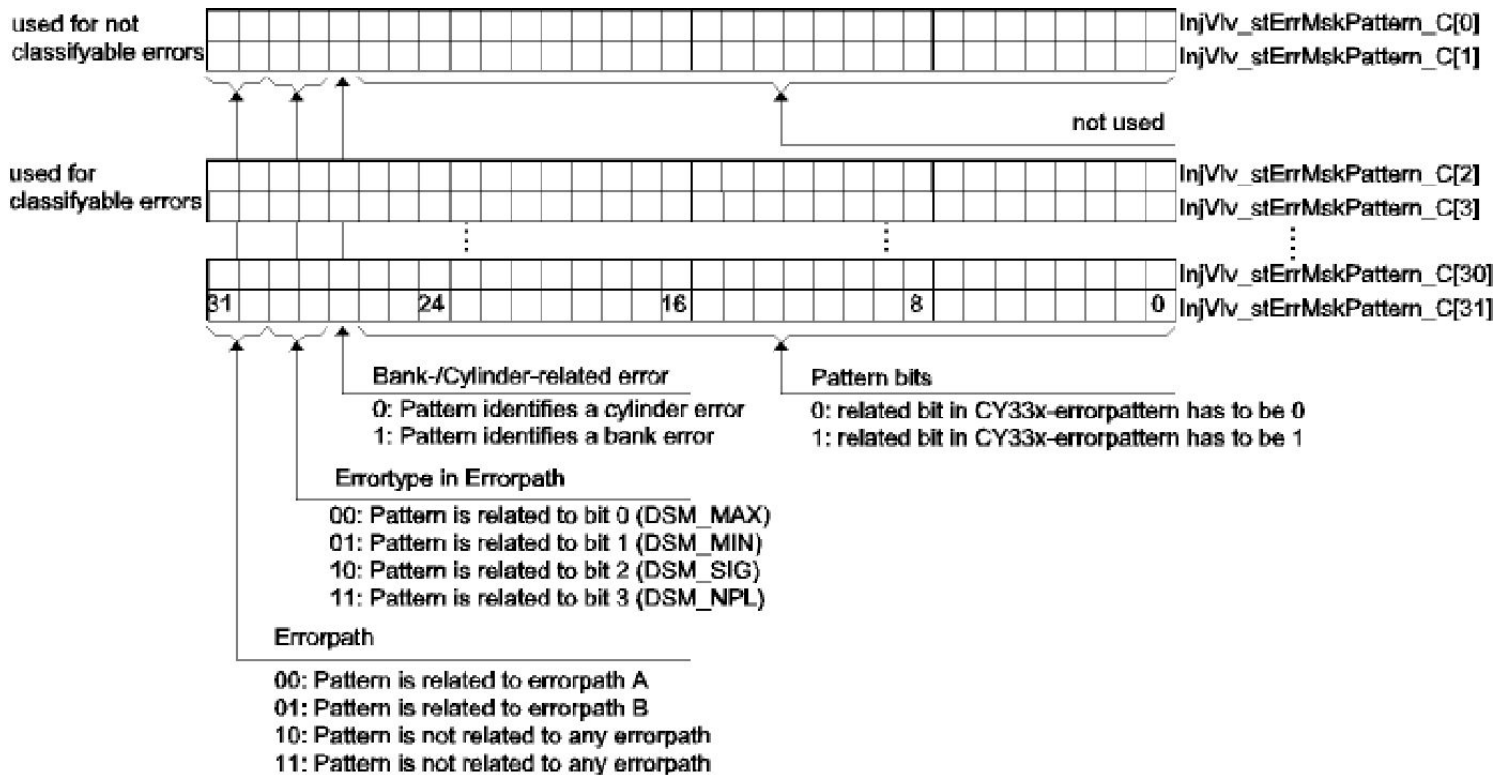

Pattern recognition sequence (4)

Structure of the select matrix

- The select matrix `InjVlv_stErrMskSelect_C` is composed of 32 entries, each 32 bits wide.
- Each entry of this matrix corresponds to the entry bearing the same number in the pattern matrix.
- The select matrix entries determine which CY33x error pattern bit is significant for the recognition of the physical error currently under consideration. **A 1 means that the corresponding bit of the component error pattern is used for pattern recognition and viceversa.** A 0 means that the corresponding bit of the pattern is not relevant for this physical error.
- Bits 27 to 31 are not used.
- Same as the pattern matrix, entries 0 and 1 handle errors which cannot be classified.

Pattern recognition sequence (5)

Structure of the select matrix

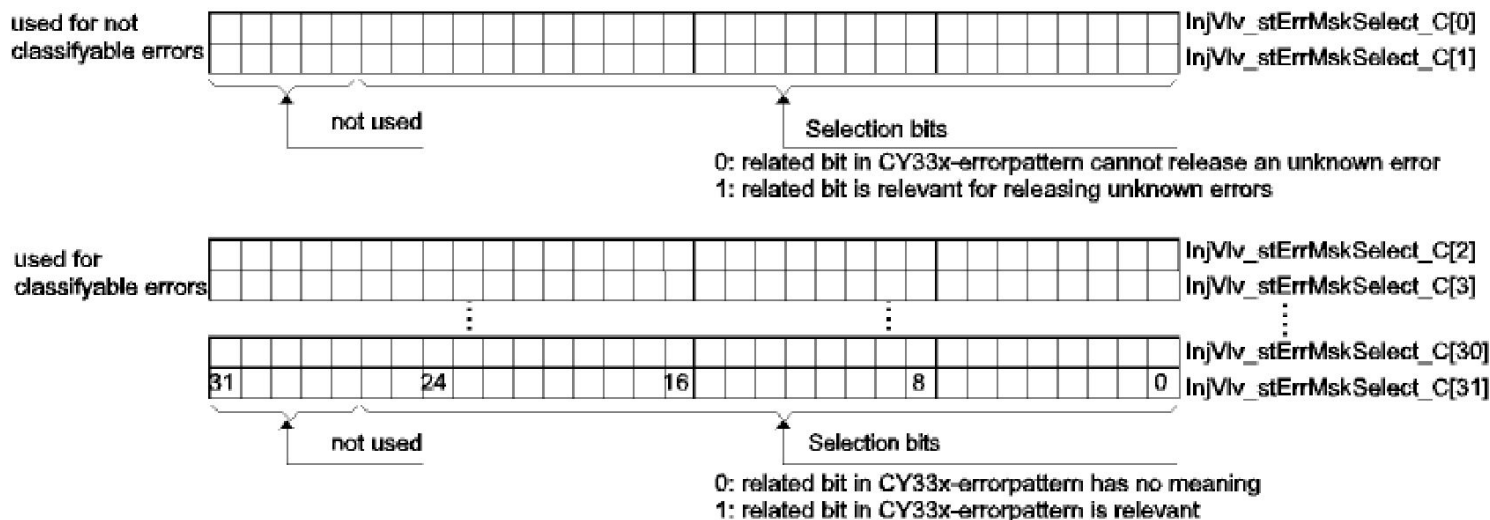

Pattern recognition sequence (6)

- First, the CY33x error pattern of each cylinder is bitwise X-ored (Exclusive-Or operation) with the pattern matrix. The result now contains a 0 for all bits which matched in the error pattern and in the pattern matrix entry and a 1 for all the others.

Pattern Matrix [i]	1	1	1	0	0	1	0	0
Pattern Error	1	0	0	0	0	1	1	0
Pattern Matrix [i] XOR Pattern Error	0	1	1	0	0	0	1	0

Pattern recognition sequence (7)

- The result is then connected bitwise to the relative select matrix entry (identical index) to perform a logical AND operation. All bits which have no significance for the current error are set to 0 and all others retain their values.

Select Matrix [i]	1	0	0	1	1	1	0	0
After XOR	0	1	1	0	1	0	1	0
Select Matrix [i] AND After XOR	0	0	0	0	1	0	0	0

Pattern recognition sequence (8)

- If the result of the logical operation is zero, then the error (which is defined in this entry of the pattern/select matrix) is recognized.
- From entry 31 to entry 2 of the pattern and select matrices, the logical operations are carried out. Here, several errors can be recognized.
- In the measuring points **InjVlv_numIdxErrCyl%_mp** (% = cyl. number) the system can display at which indices of the pattern/select matrix a match occurred. The bit number in the measuring point **InjVlv_numIdxErrCyl%_mp** corresponds to the entry number of the pattern/select matrix.

Overview of Diagnosis

Pattern recognition sequence (9)

Example of „Error identified“

Select Matrix [i]	1	0	0	1	1	1	0	0
Pattern Matrix [i]	1	1	1	0	0	1	0	0
Pattern Error	1	0	0	0	0	1	1	0
XOR	0			0	0	0		

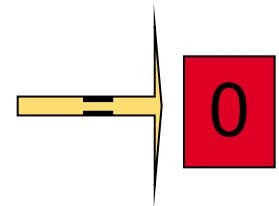

ERROR
IDENTIFIED

Overview of Diagnosis

Pattern recognition sequence (10)

Example of „Error not identified“

Select Matrix [h]	1	0	1	1	1	1	0	0
Pattern Matrix [h]	1	1	1	0	0	1	0	0
Pattern Error	1	0	0	0	0	1	1	0
XOR	0		1	0	0	0		

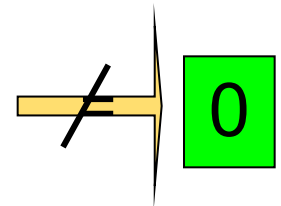

ERROR NOT IDENTIFIED

Pattern recognition sequence (11)

Example of unclassifiable error

Entries 0 and 1 of the pattern and select matrices are reserved for unclassifiable bank and cylinder errors.

If no pattern of the classified errors of the pattern/select matrix matched, the error pattern is checked for an unclassifiable error. The error pattern is compared bitwise to the relative select matrix entry to perform a logical AND operation. If the result of the AND-operation is zero, no error is detected.

Select Matrix [0-1]	1	0	0	1	1	1	0	0
Pattern Error	0	0	0	0	0	1	0	0
AND	0			0	0	1		

UNCLASSIFIABLE ERROR IDENTIFIED

Error Debouncing (1)

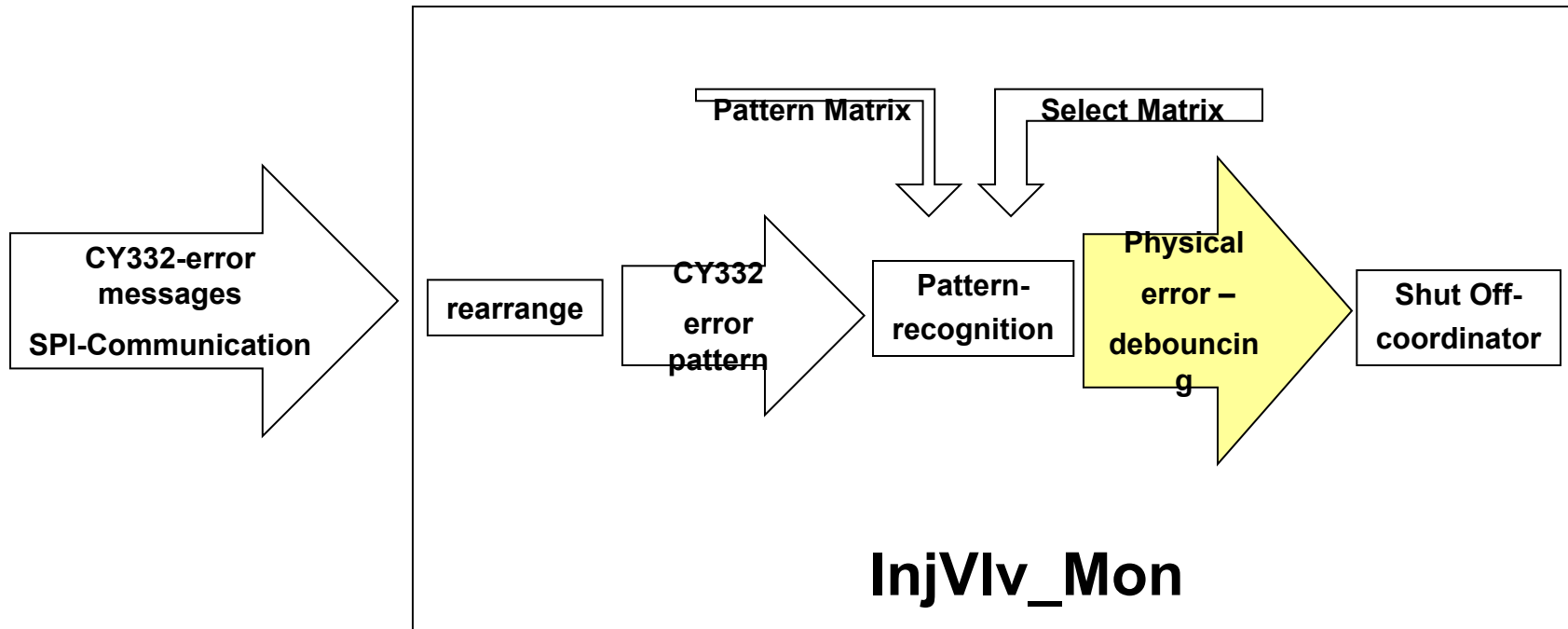

Error Debouncing (2)

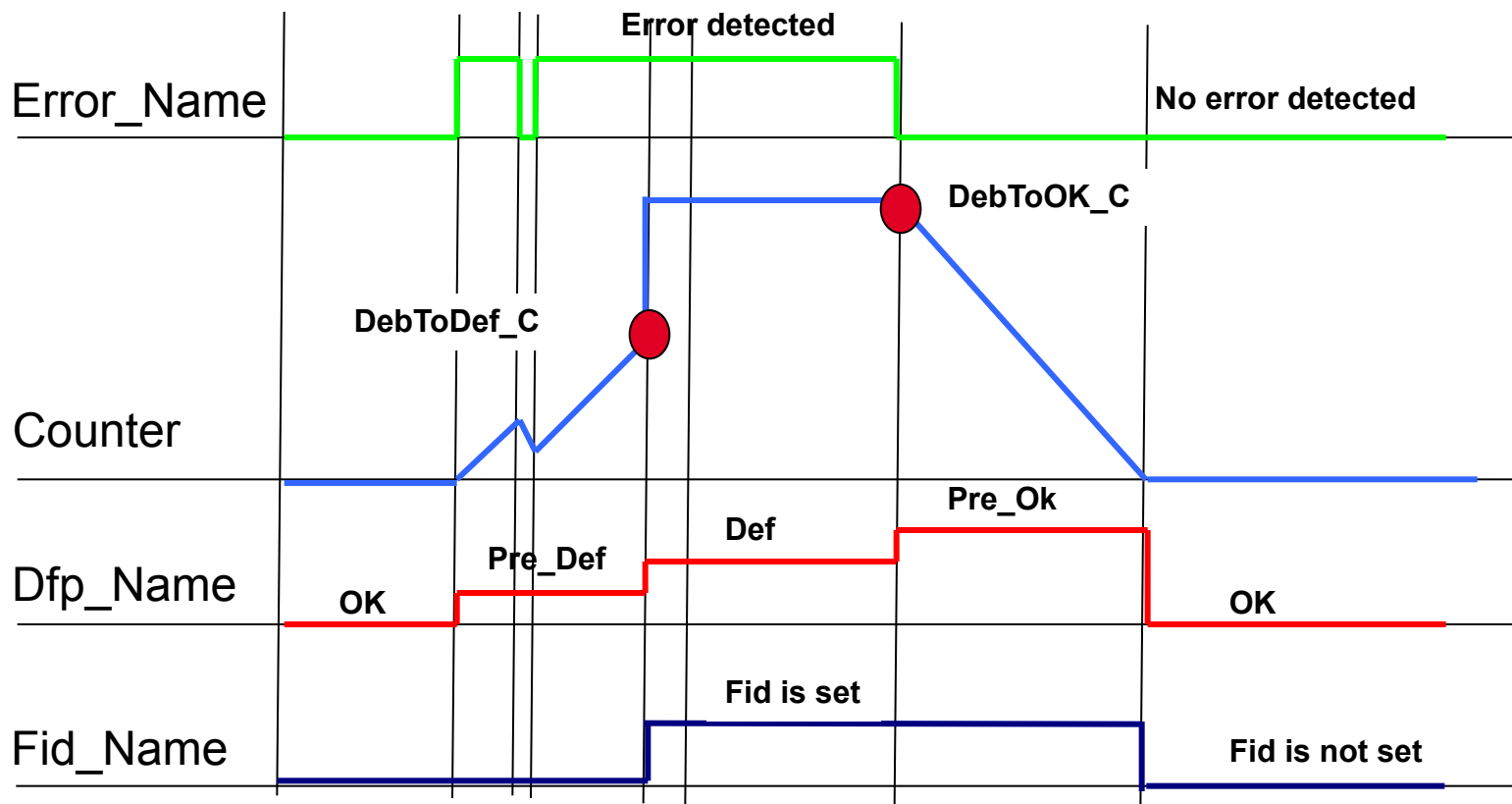

Error Debouncing (3)

Overview of DSM - Dfp_Name_mp

Bit	Meaning
0 *	Error type: Max = maximum error (eg. signal range check high).
1 *	Error type: Min = minimum error.
2 *	Error type: Sig = signal error.
3 *	Error type: Npl = not plausible error.
4	Error flag corresponding to error path. Equivalent to the result of the logical OR of all error type bits. It indicates that the last pre-debounced test result of the error path was an error.
5	Cycle flag corresponding to error path. It indicates that the error path has already been completely tested since terminal 15 was activated (or an error has occurred).

- * Only 1 error type is set at a time. The error types are prioritized among each other. The monitoring function determines the order of priority. The meaning of the error types for a specific error path has to be taken from the software documentation of the error path or from the automatically generated comprehensive table in the appendix.

Error Debouncing (4)

Overview of DSM - Dfp_Name_mp

Bit	Meaning
6	Substitution value flag of the error path. It means that the signal corresponding to the error path is only a substitute value at the moment (and not a real-time value).
7	Memory flag corresponding to error path. It means that the error path has been stored into the error memory.
8	Debounce active Flag. Set as long as pre-debouncing for the error path is active (defect or healing pre-debouncing). Functional for all pre-debounces which use the library functions.
9	Zpf (cycle since power fail): <ul style="list-style-type: none">- is reset when the error memory is deleted.- is set in the after run if:<ul style="list-style-type: none">- the error path was tested during the driving cycle and it has not stored in the memory.- the error path is already present in the memory, then no error must be present in the error path through out the driving cycle. If the bit was set once, it stays set until the error memory is deleted again.
10-15	not used.

Error Debouncing (5)

Overview of DSM - Fid_Name_mp

- Permission (Bit 0) is equal to 1 for non-inhibited Fids. If a Fid is inhibited due to an error, the permission becomes 0.
- Bit 1- 3: Free
- Bit 4 - 7 indicate the number of defective paths that inhibit the Fid. Limit value for the display is 15.

For more information about DSM functions, see:

- http://ganga.ban.in.bosch.com/edc16asw/01_DSM/dsm_docus/

InjVlv_Mon Labels (1)

Measuring points

- **Dfp_InjVlv_Bnk%\$_mp** (% = 1,..., number of banks \$ = A, B) (Error path \$ for Bank %)
- **Dfp_InjVlv_Cyl%\$_mp** (% = 1,..., number of cylinder \$ = A, B) (Error path \$ for Cylinder %)
- **InjVlv_numIdxErrCyl%_mp** (% = 1,..., number of cylinder) (Indices of detected patterns for cylinder %)
- **InjVlv_stErrCyl%_mp** (% = 1,..., number of cylinder) (internal CY33x cylinder error register for cylinder %)

InjVlv_Mon Labels (1)

Output values

- InjVlv_stErrBnk% (% = 1,..., number of banks) (internal CY33x bank error register for Bank %)
- InjVlv_stErrClctCyl% (% = 1,..., number of cylinder) (Cumulative error message for cylinder %)

InjVlv_Mon Labels (2)

Application parameters

- InjVlv_DebBnk\$%Def_C (\$ = A, B % = 0, 1, 2, 3) (Defect debounce for bank error path \$, %=0=> Bit MAX, %=1=> Bit MIN, ...)
- InjVlv_DebBnk\$%Ok_C (\$ = A, B % = 0, 1, 2, 3) (Healing debounce for bank error path \$, %=0=> Bit MAX, %=1=> Bit MIN, ...)
- InjVlv_DebCyl\$%Def_C (\$ = A, B % = 0, 1, 2, 3) (Defect debounce for cylinder error path \$, %=0=> Bit MAX, %=1=> Bit MIN, ...)
- InjVlv_DebCyl\$%Ok_C (\$ = A, B % = 0, 1, 2, 3) (Healing debounce for cylinder error path \$, %=0=> Bit MAX, %=1=> Bit MIN, ...)
- InjVlv_stErrMskPattern_C (Pattern matrix for pattern recognition)
- InjVlv_stErrMskSelect_C (Select matrix for pattern recognition)

Particularity for CV-System (1)

Split injection - No FDE (only U-System)

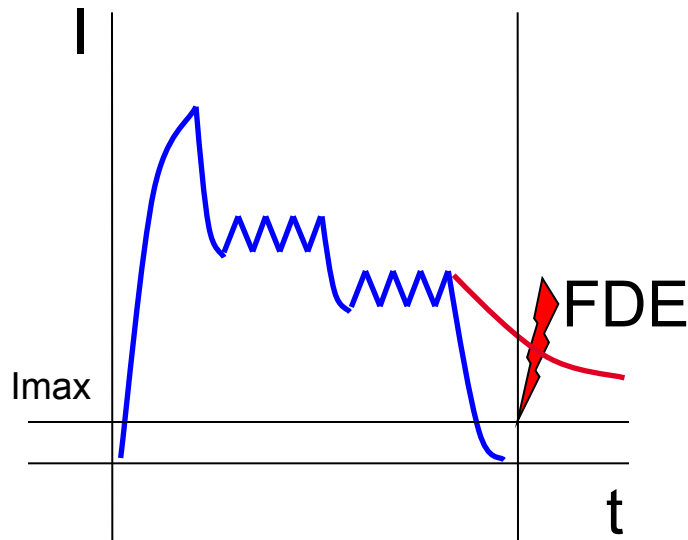

FDE Check

Fast Decay Check without Split-Injections

The FD (Fast Decay) time specifies how fast the magnetic residual energy of the injector gets dissipated. This influences the closing time of the injector needle.

The FD check test must take place.

Particularity for CV-System (2)

Split injection - No FDE (only U-System)

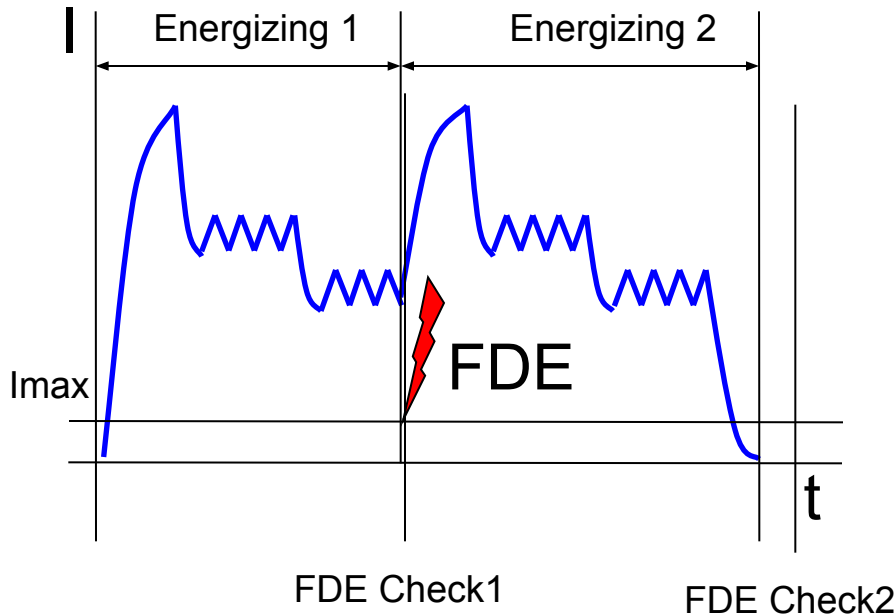

Presently, in the U-Systems it is possible that the energizing time exceeds the specification of powerstage module (aprox. 15 ms). In this case long injections are split-up in several energizes. This leads to a FD error recognition that should not be stored.

Fast Decay Check with Split-Injections

Particularity for CV-System (3)

Booster Time-out Error

- The error "Booster Time-out Error" can appear if:
 - the DC-DC converter has a big loss in performance.
 - because of a very low temperature at start of engine ("Cold Start") in combination with aged electrolytic capacitors ("false error"). With a warmed up EDC this "false error" does not appear any more.
- In case of "Cold Start", no error should be stored in the EDC.

Agenda

- Vision general of diagnosis
- Solenoid Valve Monitoring of CR- & U-System
- **Outcomes of the Short Circuits**
 - No Error
 - Open Circuit
 - Short Circuit High Side to Battery
 - Short Circuit High Side to Ground
 - Short Circuit Low Side to Battery
 - Short Circuit Low Side to Ground
 - Short Circuit High Side to Low Side
- Solenoid Valve Monitoring Shut Off
- Application procedure
- Actual platform application
- Peculiarity 8 Cylinder software with multiplexer

No Error

Current at Injector and from Battery to ECU for an UI-System (N2 Injector)

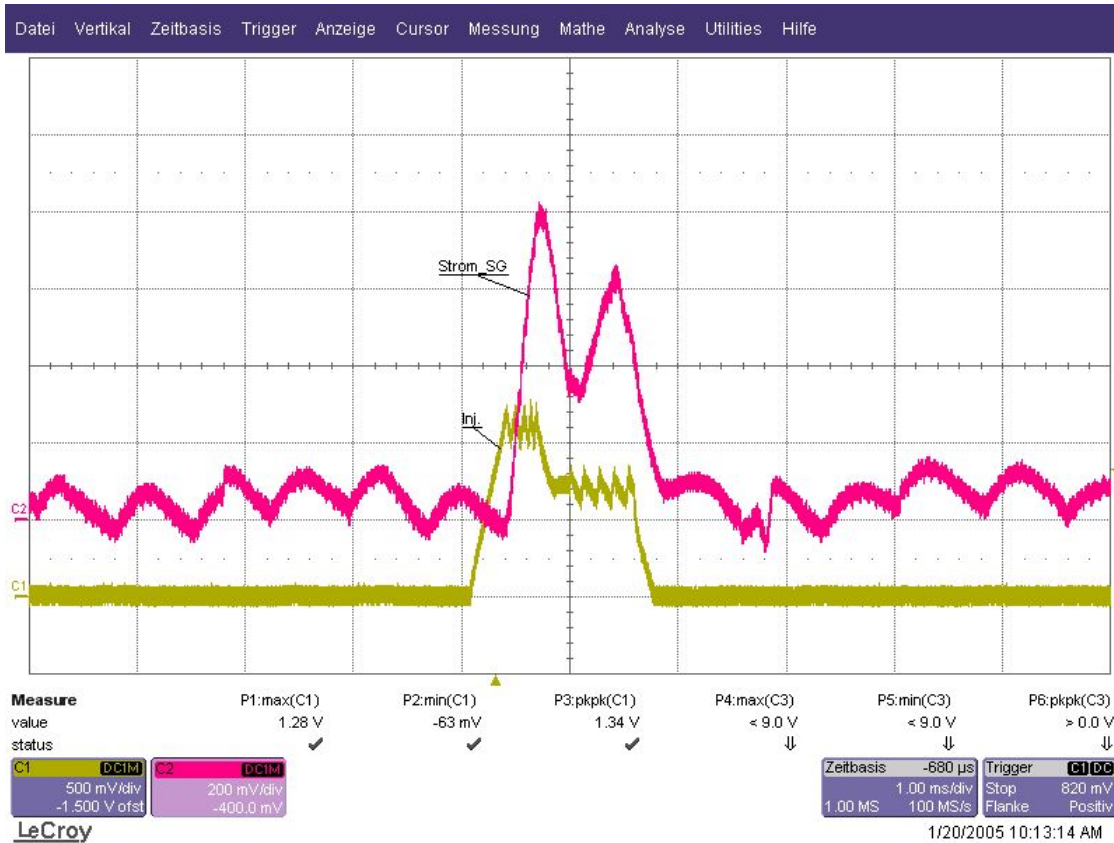

Overview of Diagnosis

Open Circuit (1)

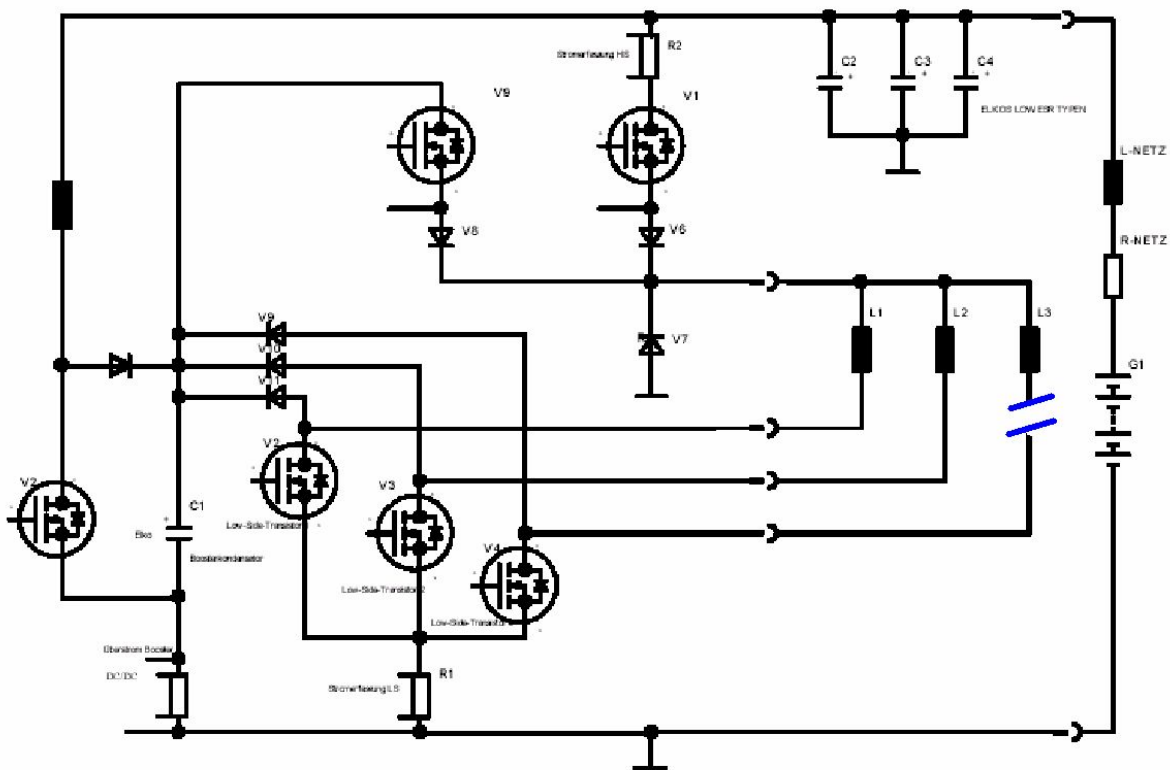

Open Circuit (2)

Cylinder specific error - InjVlv_stErrCyl\$_mp

BIT	CY332 ERROR	a.C.	i.C.
0	Maximal current in HS-Switch	0	0
1	Maximal current in LS-Switch	0	0
2	Differential current (HS-LS)	0	0
3	No load detected (open circuit)	1	0
4	Fast decay check failure	0	0
5	-	0	0
6	Current level error	1	0
7	Injection Finished	1	1

a.C. : Active Cylinder – CY33x-error message of the Cylinder with the physical error

i.C. : Inactive Cylinder – CY33x-error message of one of the Cylinder in the same bank as the Cylinder with the physical error

Open Circuit (3)

Bank specific error - InjVlv_stErrBnk\$_mp

BIT	CY332 ERROR	
0	Booster voltage Over-range error	0
1	Booster voltage Under-range Error	0
2	Booster current-Low Error	1
3	Booster current-High Error	0
4	Booster Time-out Error	0
5	-	0
6	LS current Error	0
7	ON signal time out	0

Short Circuit High Side to Battery (1)

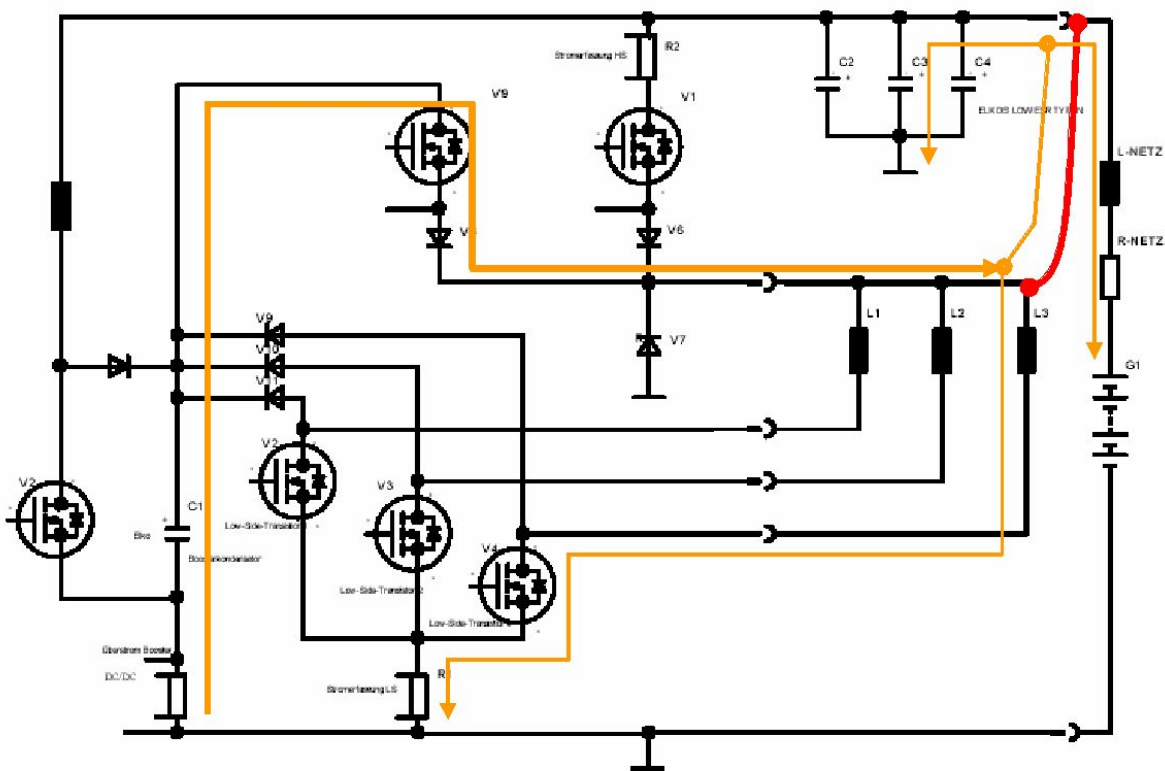

Overview of Diagnosis

Short Circuit High Side to Battery (2)

Current at HS of the Injector



Short Circuit High Side to Battery (3)

Current at LS of the Injector

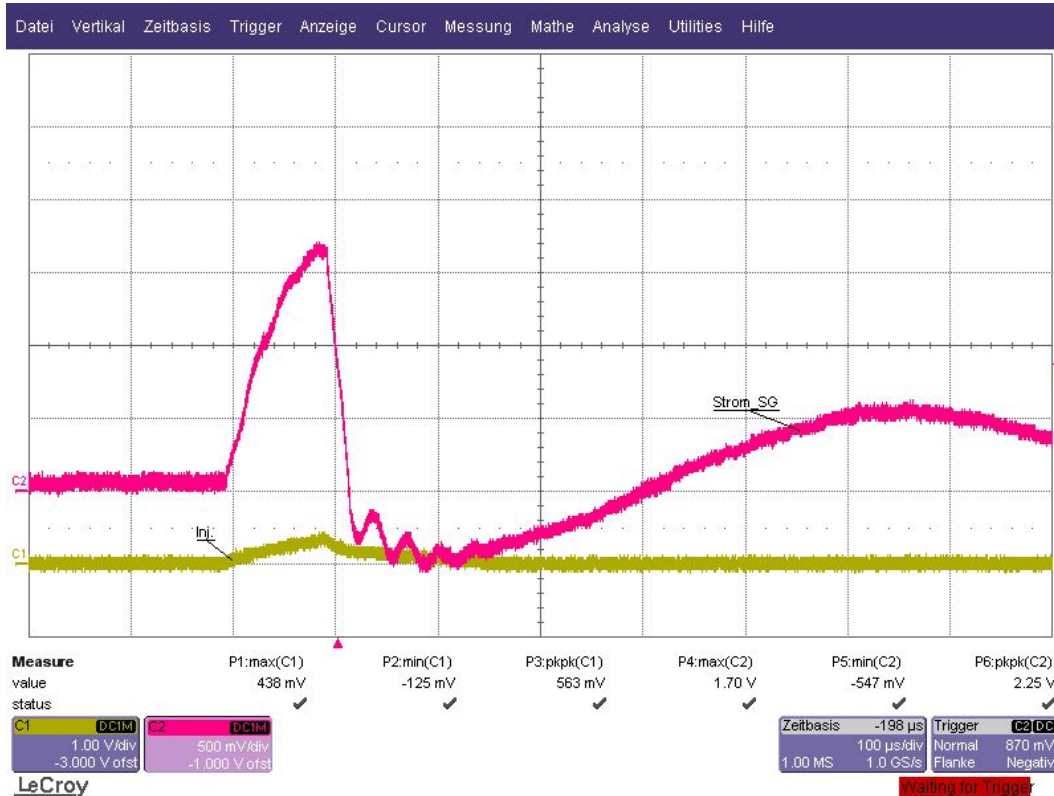

Short Circuit High Side to Battery (4)

Cylinder specific error - InjVlv_stErrCyl\$_mp

BIT	CY332 ERROR	a.C.	i.C.
0	Maximal current in HS-Switch	0	0
1	Maximal current in LS-Switch	0	0
2	Differential current (HS-LS)	0	0
3	No load detected (open circuit)	1	1
4	Fast decay check failure	0	0
5	-	0	0
6	Current level error	1	1
7	Injection Finished	1	1

SCHSBA is a Bank Error – No CY33x-error message differences between a.C. and i.C.

Short Circuit High Side to Battery (5)

Bank specific error - InjVlv_stErrBnk\$_mp

BIT	CY332 ERROR	
0	Booster voltage Over-range error	0
1	Booster voltage Under-range Error	0
2	Booster current-Low Error	0
3	Booster current-High Error	1
4	Booster Time-out Error	0
5	-	0
6	LS current Error	0
7	ON signal time out	0

Short Circuit High Side to Ground (1)

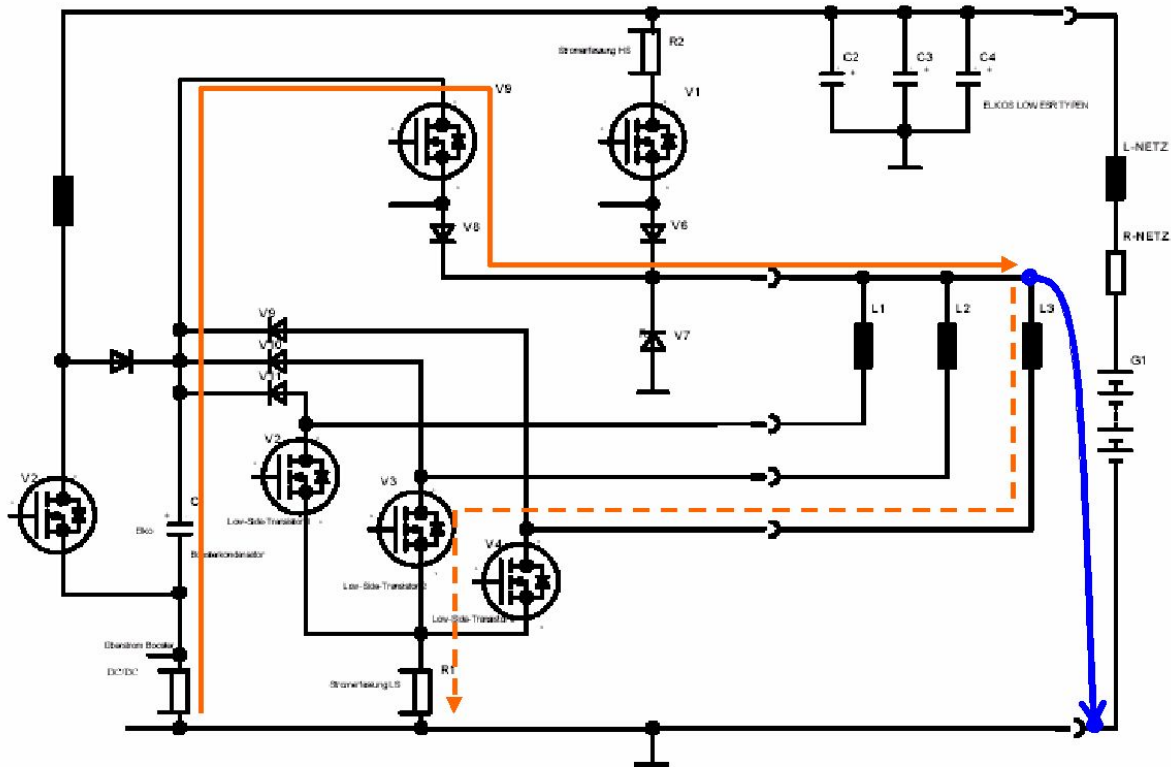

Short Circuit High Side to Ground (2)

Current at HS of the Injector

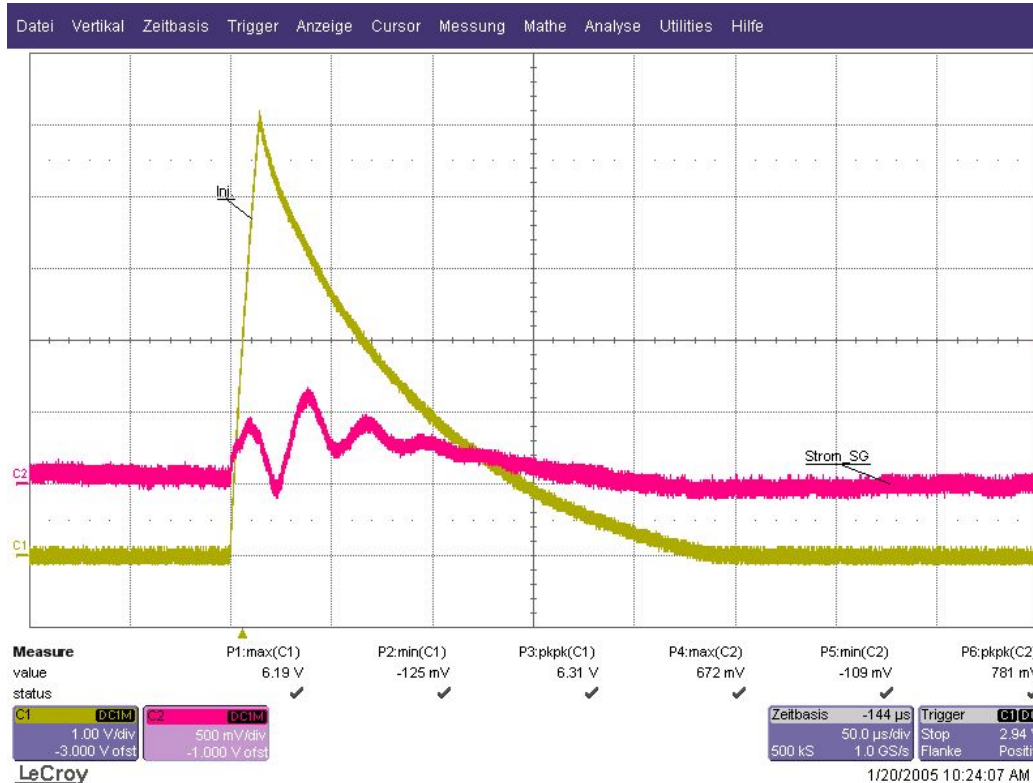

Short Circuit High Side to Ground (3)

Cylinder specific error - InjVlv_stErrCyl\$_mp

BIT	CY332 ERROR	a.C.	i.C.
0	Maximal current in HS-Switch	0	0
1	Maximal current in LS-Switch	0	0
2	Differential current (HS-LS)	0	0
3	No load detected (open circuit)	1	1
4	Fast decay check failure	0	0
5	-	0	0
6	Current level error	1	1
7	Injection Finished	1	1

SCHSGN is a Bank Error – No CY33x-error message differences between a.C. and i.C.

Short Circuit High Side to Ground (4)

Bank specific error - InjVlv_stErrBnk\$_mp

BIT	CY332 ERROR	
0	Booster voltage Over-range error	0
1	Booster voltage Under-range Error	0
2	Booster current-Low Error	0
3	Booster current-High Error	1
4	Booster Time-out Error	0
5	-	0
6	LS current Error	0
7	ON signal time out	0

Overview of Diagnosis

Short Circuit Low Side to Battery (1)

Current flow if active Cylinder is powered

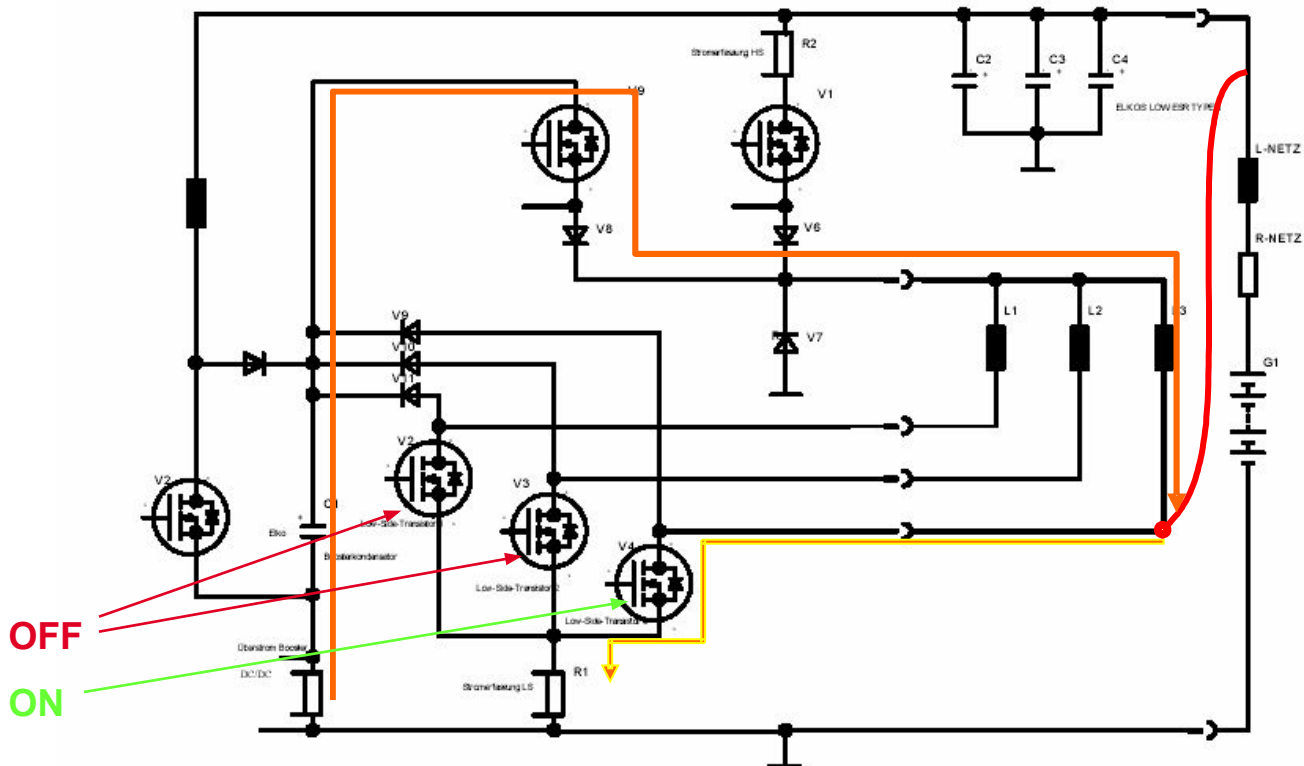

Overview of Diagnosis

Short Circuit Low Side to Battery (2)

Current flow if active Cylinder is not powered

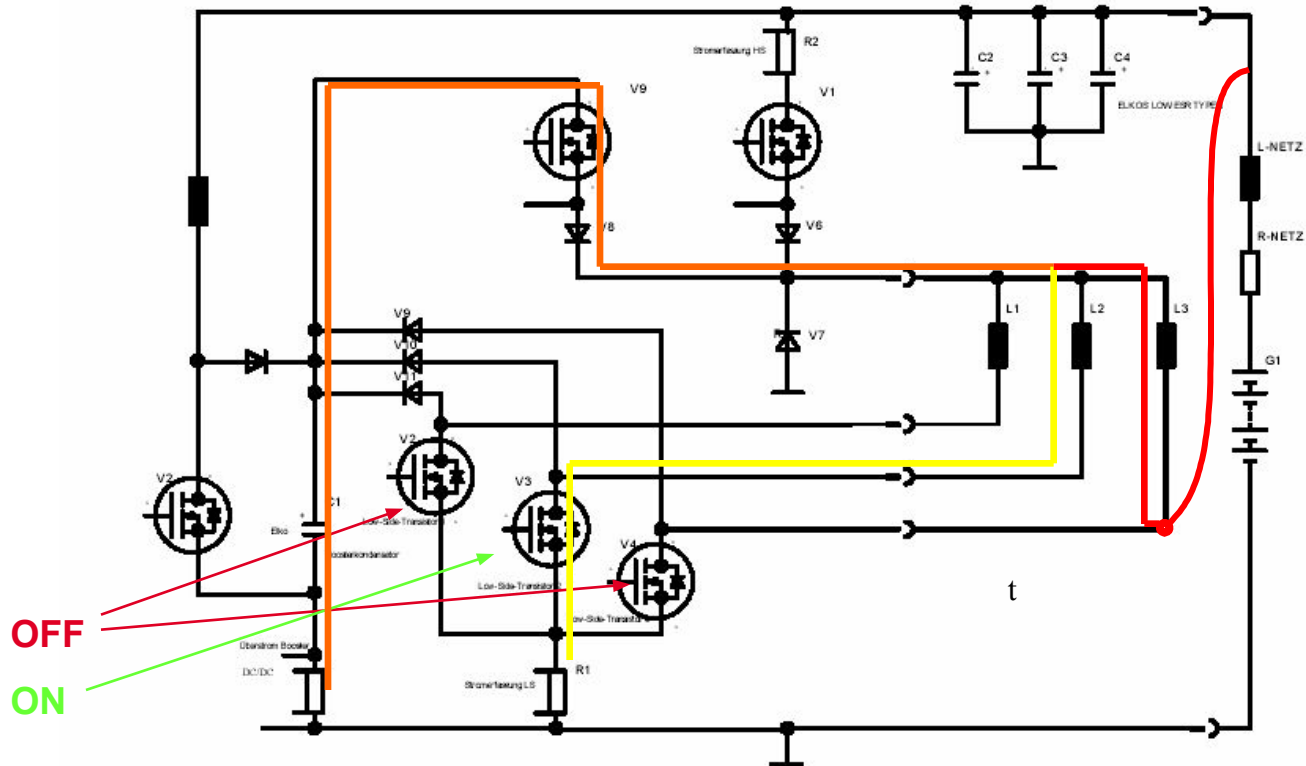

Short Circuit Low Side to Battery (3)

Current at HS of the Injector

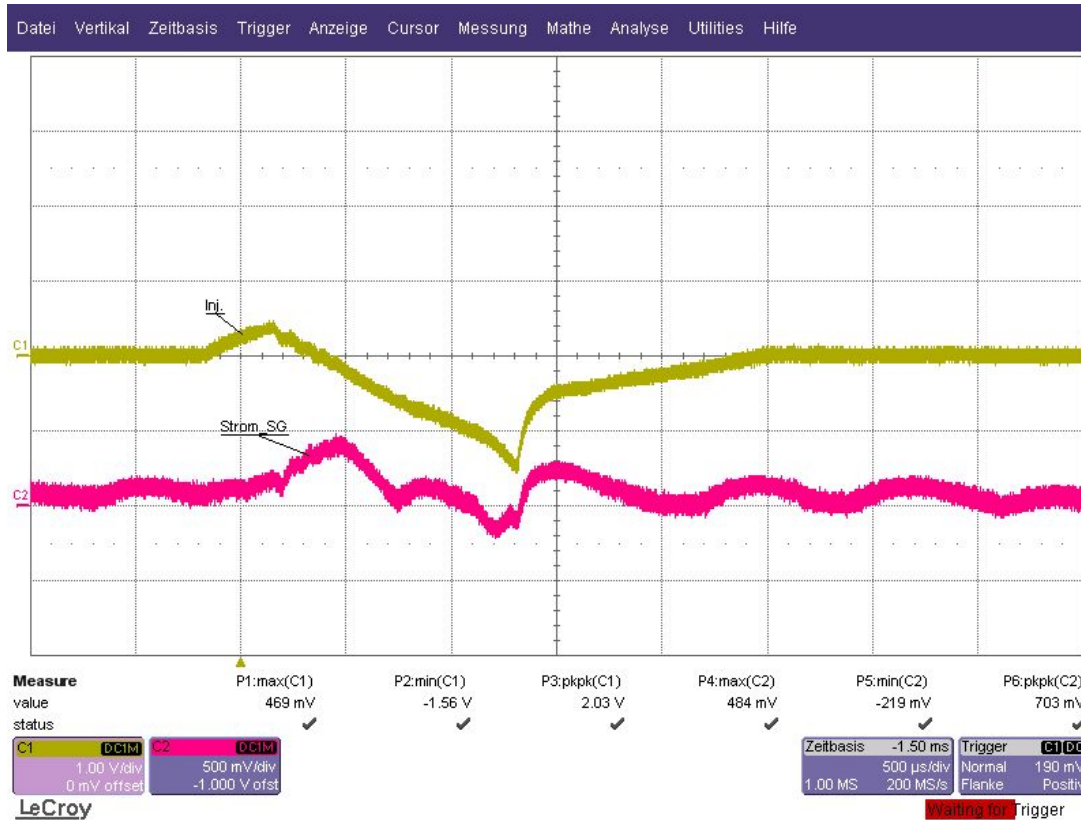

Short Circuit Low Side to Battery (4)

Current at LS of the Injector

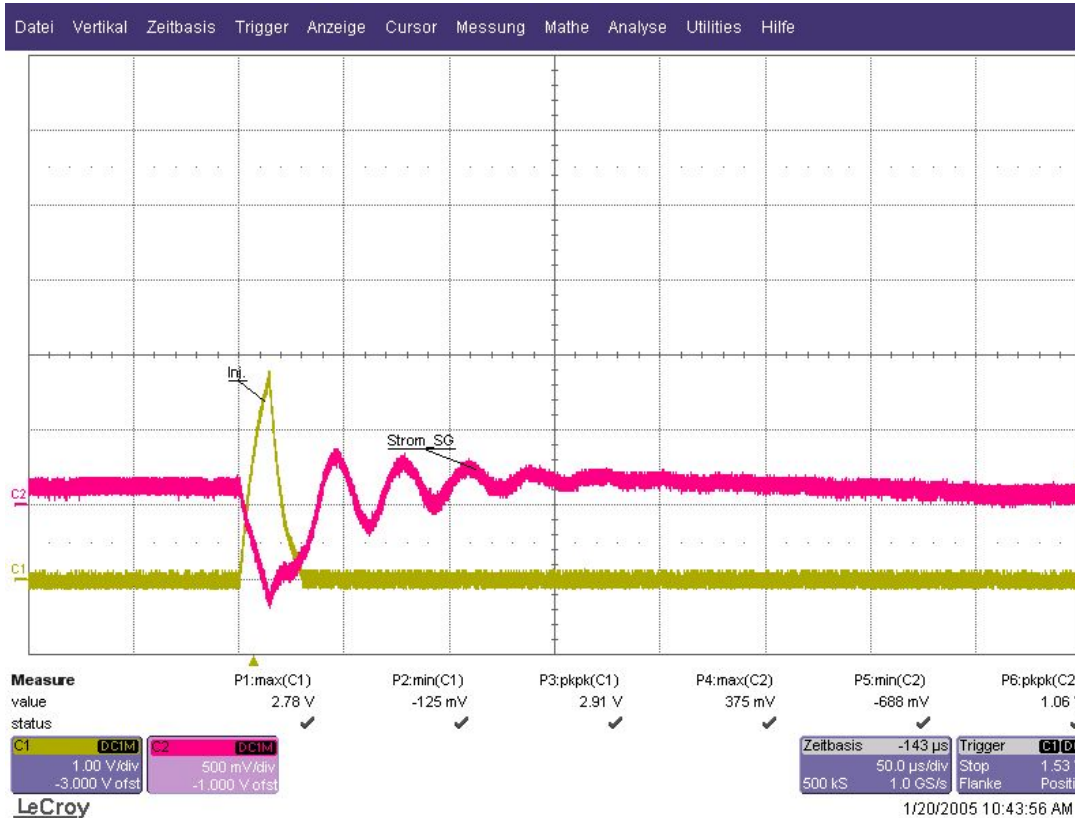

Short Circuit Low Side to Battery (5)

Cylinder specific error - InjVlv_stErrCyl\$_mp

BIT	CY332 ERROR	a.C.	i.C.
0	Maximal current in HS-Switch	0	0
1	Maximal current in LS-Switch	1	0
2	Differential current (HS-LS)	0	X
3	No load detected (open circuit)	0	0
4	Fast decay check failure	0	0
5	-	0	0
6	Current level error	0	0
7	Injection Finished	1	1

X= 0 or 1 depending on the environment conditions, short circuit impedance...

Short Circuit Low Side to Battery (6)

Bank specific error - InjVlv_stErrBnk\$_mp

BIT	CY332 ERROR	
0	Booster voltage Over-range error	0
1	Booster voltage Under-range Error	0
2	Booster current-Low Error	0
3	Booster current-High Error	0
4	Booster Time-out Error	0
5	-	0
6	LS current Error	0
7	ON signal time out	0

Overview of Diagnosis

Short Circuit Low Side to Ground (1)

Current flow if active Cylinder is powered

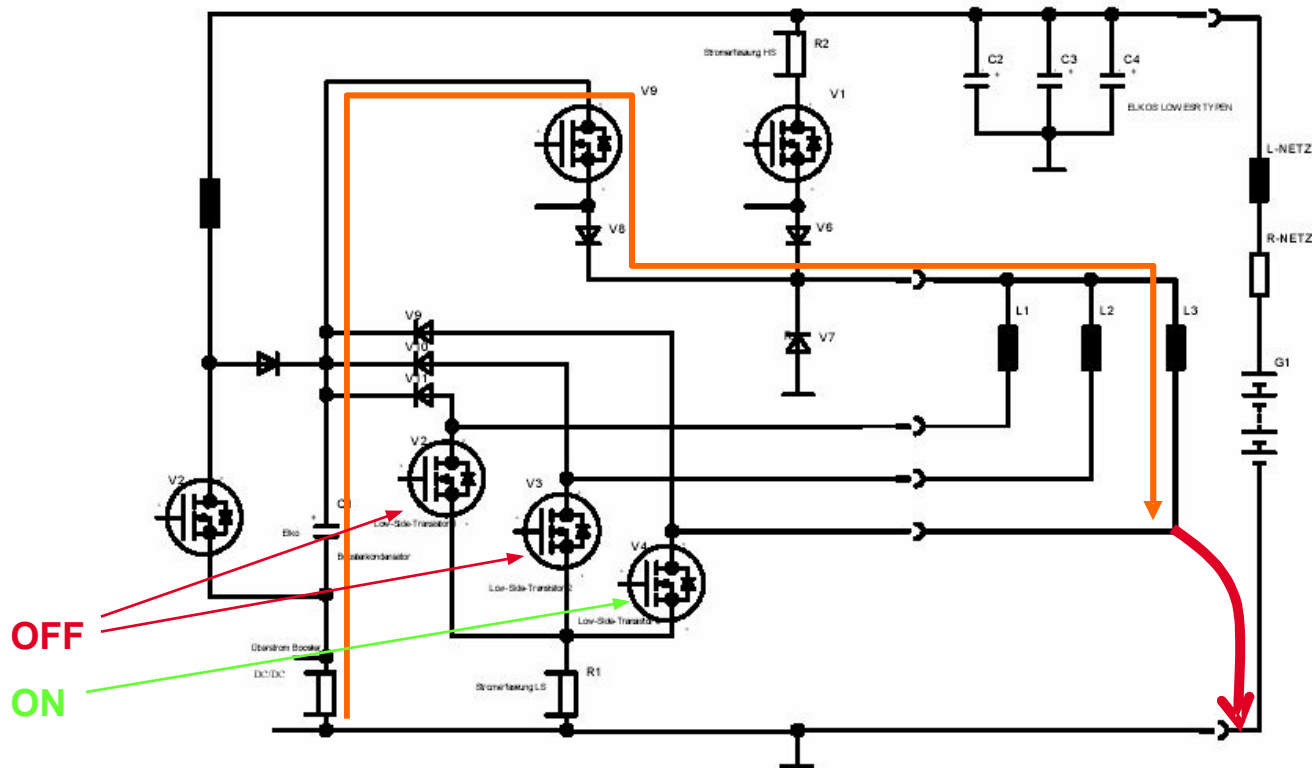

Overview of Diagnosis

Short Circuit Low Side to Ground (2)

Current flow if active Cylinder is not powered

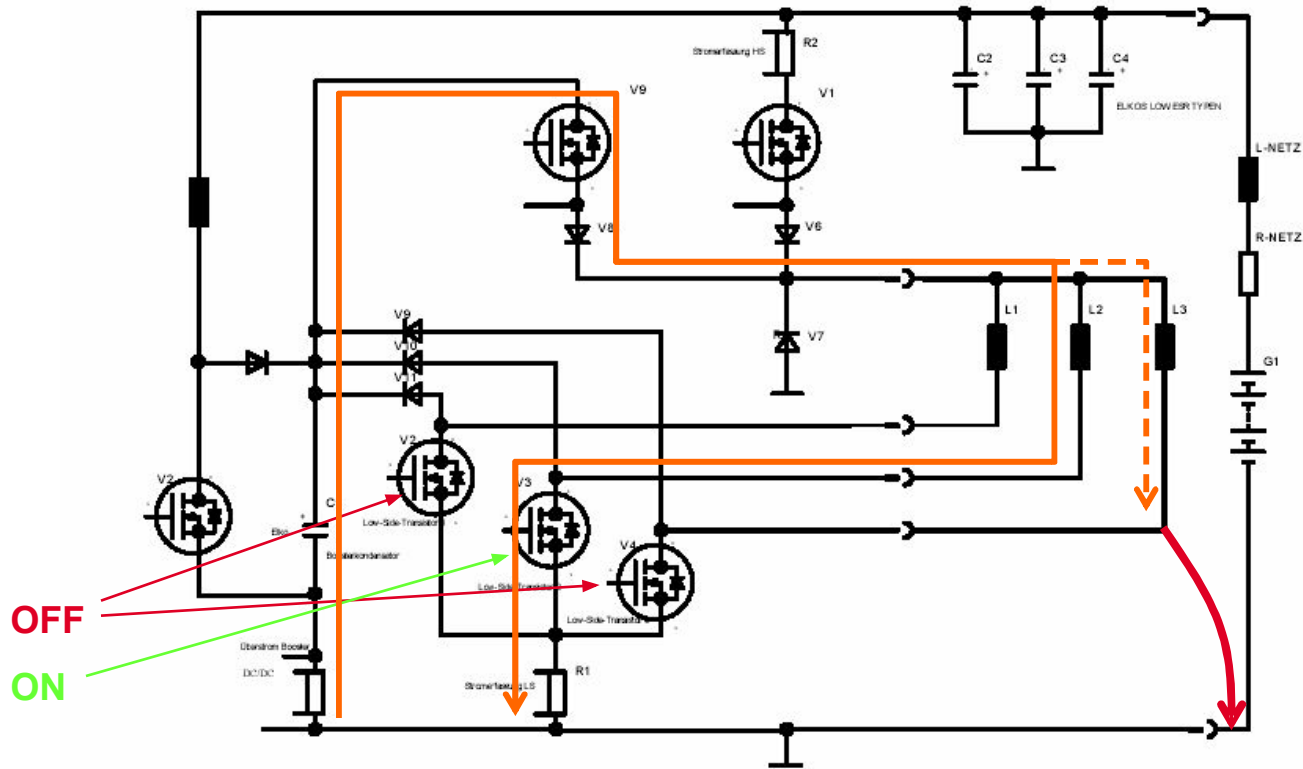

Short Circuit Low Side to Ground (3)

Current at HS of the Injector

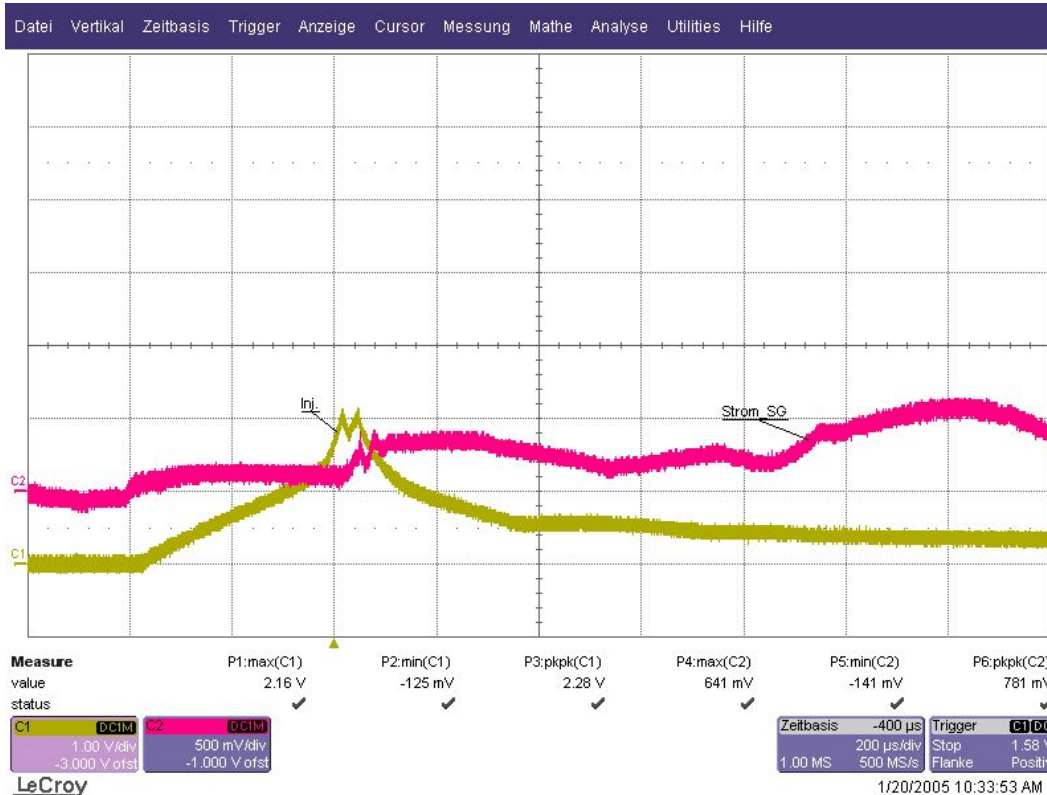

Short Circuit Low Side to Ground (4)

Cylinder specific error - InjVlv_stErrCyl\$_mp

BIT	CY332 ERROR	a.Z.	i.Z.
0	Maximal current in HS-Switch	0	1
1	Maximal current in LS-Switch	0	0
2	Differential current (HS-LS)	1	1
3	No load detected (open circuit)	0	0
4	Fast decay check failure	0	0
5	-	0	0
6	Current level error	0	0
7	Injection Finished	1	1

Short Circuit Low Side to Ground (5)

Bank specific error - InjVlv_stErrBnk\$_mp

BIT	CY332 ERROR	
0	Booster voltage Over-range error	0
1	Booster voltage Under-range Error	0
2	Booster current-Low Error	0
3	Booster current-High Error	0
4	Booster Time-out Error	0
5	-	0
6	LS current Error	0
7	ON signal time out	0

Short Circuit High Side to Low Side (1)

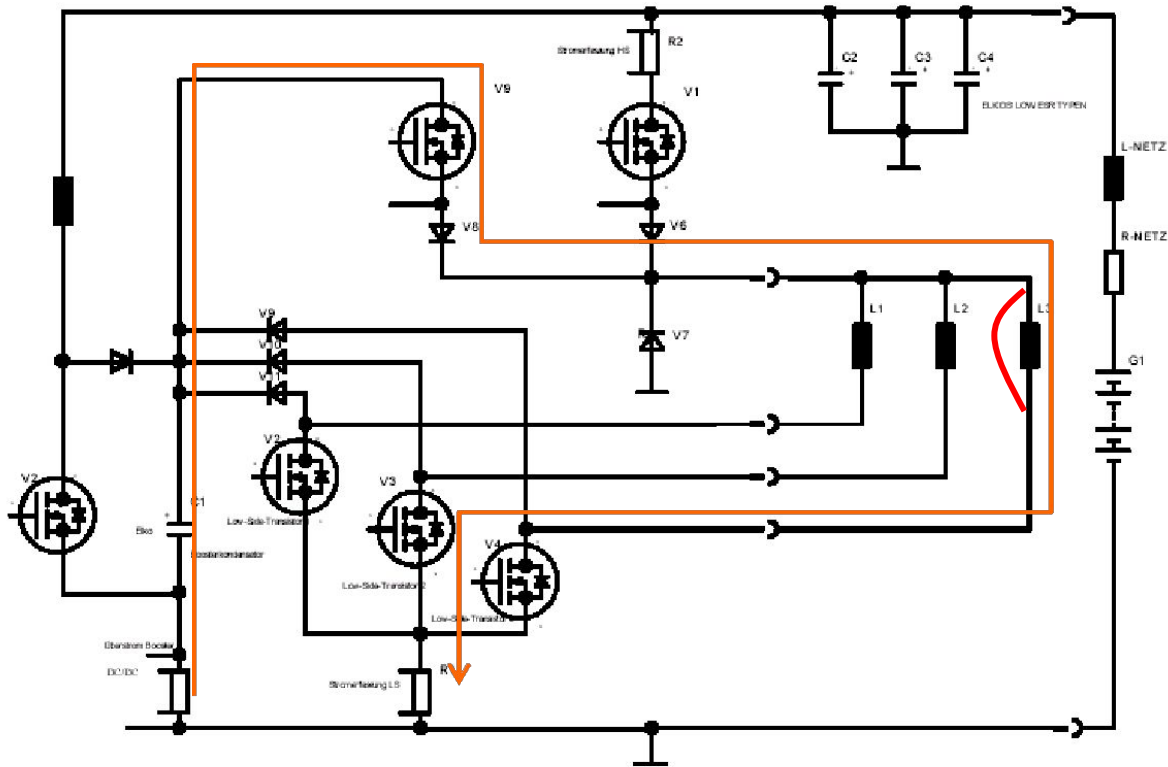

Short Circuit High Side to Low Side (2)

Current at HS of the Injector = Current at LS of the Injector

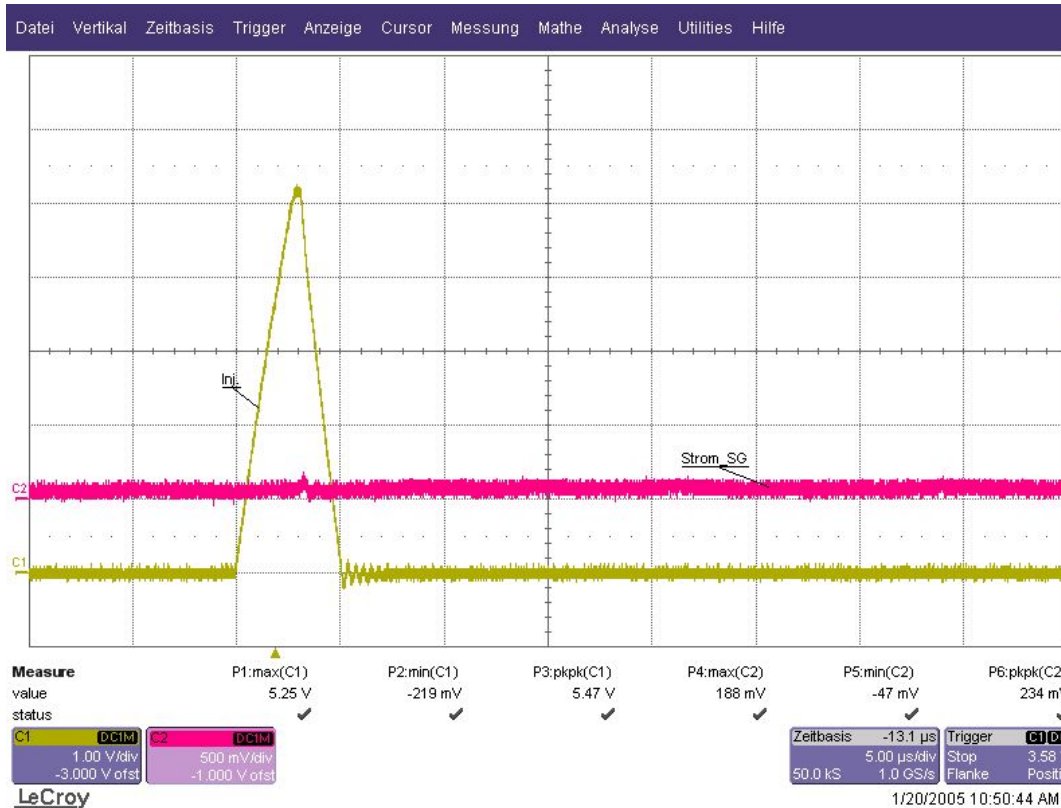

Short Circuit High Side to Low Side (3)

Cylinder specific error - InjVlv_stErrCyl\$_mp

BIT	CY332 ERROR	a.Z.	i.Z.
0	Maximal current in HS-Switch	0	0
1	Maximal current in LS-Switch	1	0
2	Differential current (HS-LS)	0	1
3	No load detected (open circuit)	0	0
4	Fast decay check failure	0	0
5	-	0	0
6	Current level error	1	0
7	Injection Finished	1	1

Short Circuit High Side to Low Side (4)

Bank specific error - InjVlv_stErrBnk\$_mp

BIT	CY332 ERROR	
0	Booster voltage Over-range error	0
1	Booster voltage Under-range Error	0
2	Booster current-Low Error	0
3	Booster current-High Error	0
4	Booster Time-out Error	0
5	-	0
6	LS current Error	0
7	ON signal time out	0

Agenda

- Vision general of diagnosis
- Solenoid Valve Monitoring of CR- & U-System
- Outcomes of the Short Circuits
- **Solenoid Valve Monitoring Shut Off**
 - Monitoring Shut Off Overview (InjVlv_MonShOff)
 - Scheduling of diagnosis Shut Off
 - State machine of the diagnosis Shut Off
 - Diagnosis Shut Off debouncing
 - Shut Off Application
 - InjVlv_MonShOff Labels
- Application procedure
- Actual platform application
- Peculiarity 8 Cylinder software with multiplexer

Monitoring-Shut Off Overview (InjVlv_MonShOff) (1)

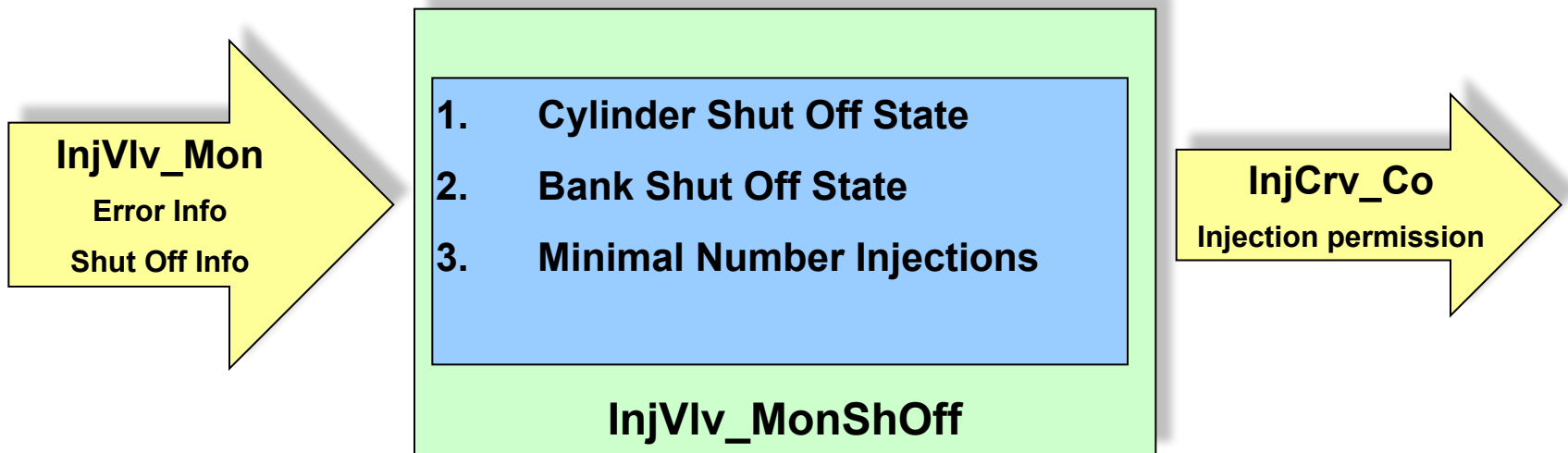

Overview of Diagnosis

Monitoring-Shut Off Overview (InjVlv_MonShOff) (2)

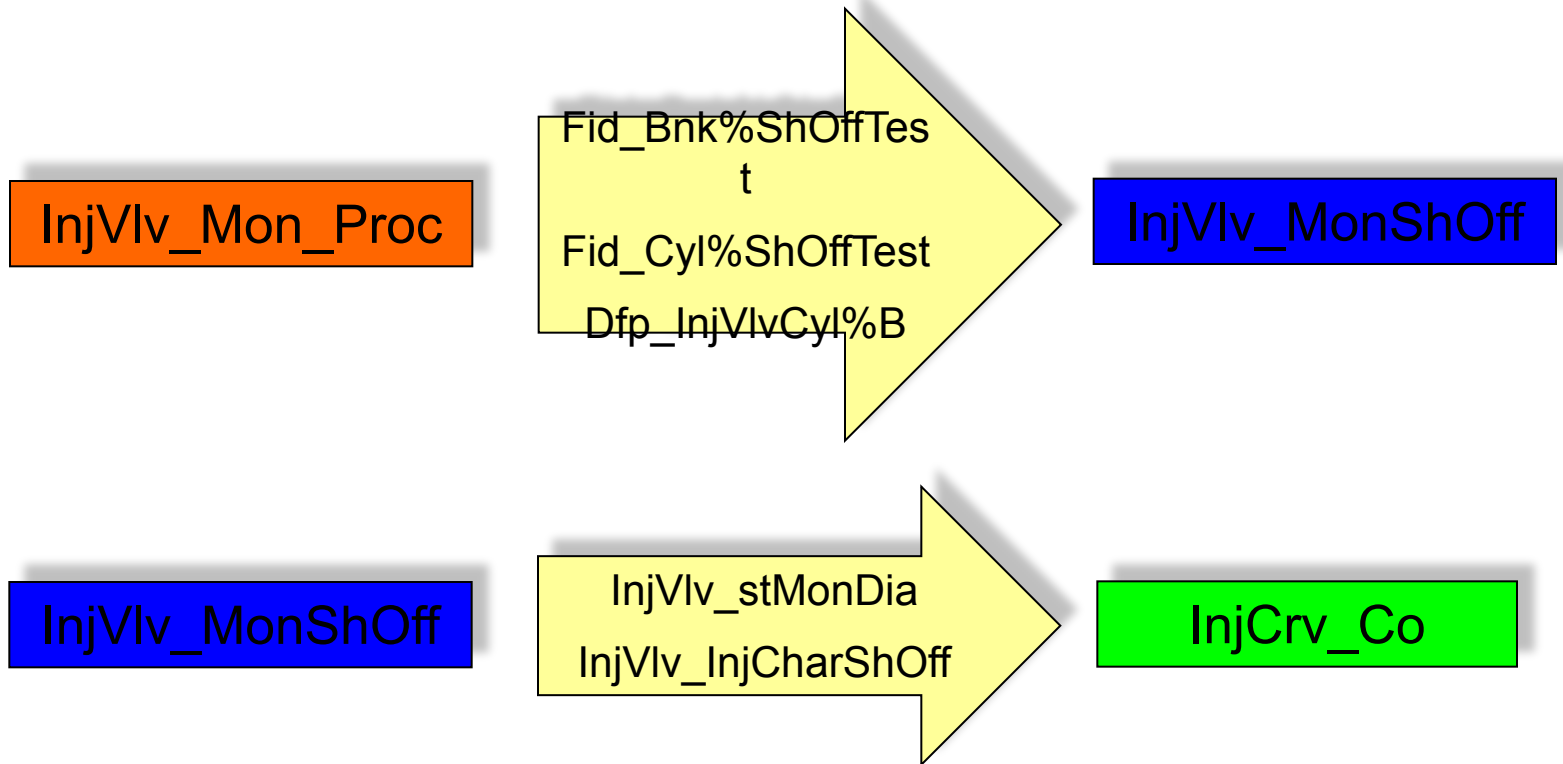

Scheduling of the diagnosis Shut Off

This function checks the error paths relevant to an injector and Shuts Off an injector or bank to enable continued driving using the injector bank which is still working.

Via application, a "Switch-On-Test" can be performed.

The function InjVlv_MonShoff must be scheduled right before the injection coordinator (InjCrv_Co). No other process is allowed to be scheduled between this two processes.

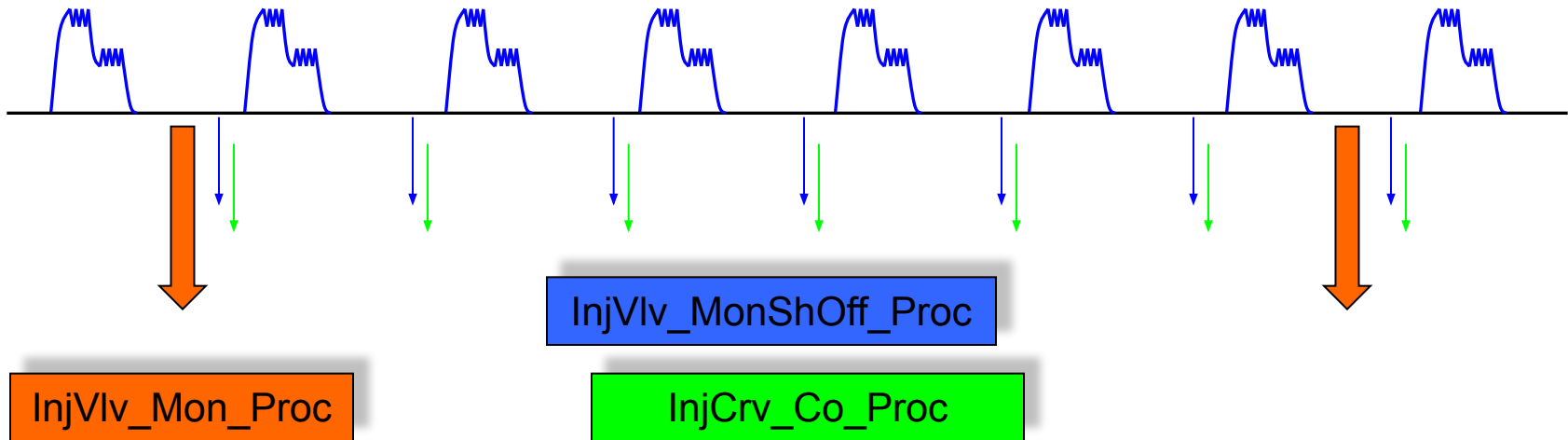

State machine of the diagnosis Shut Off (1)

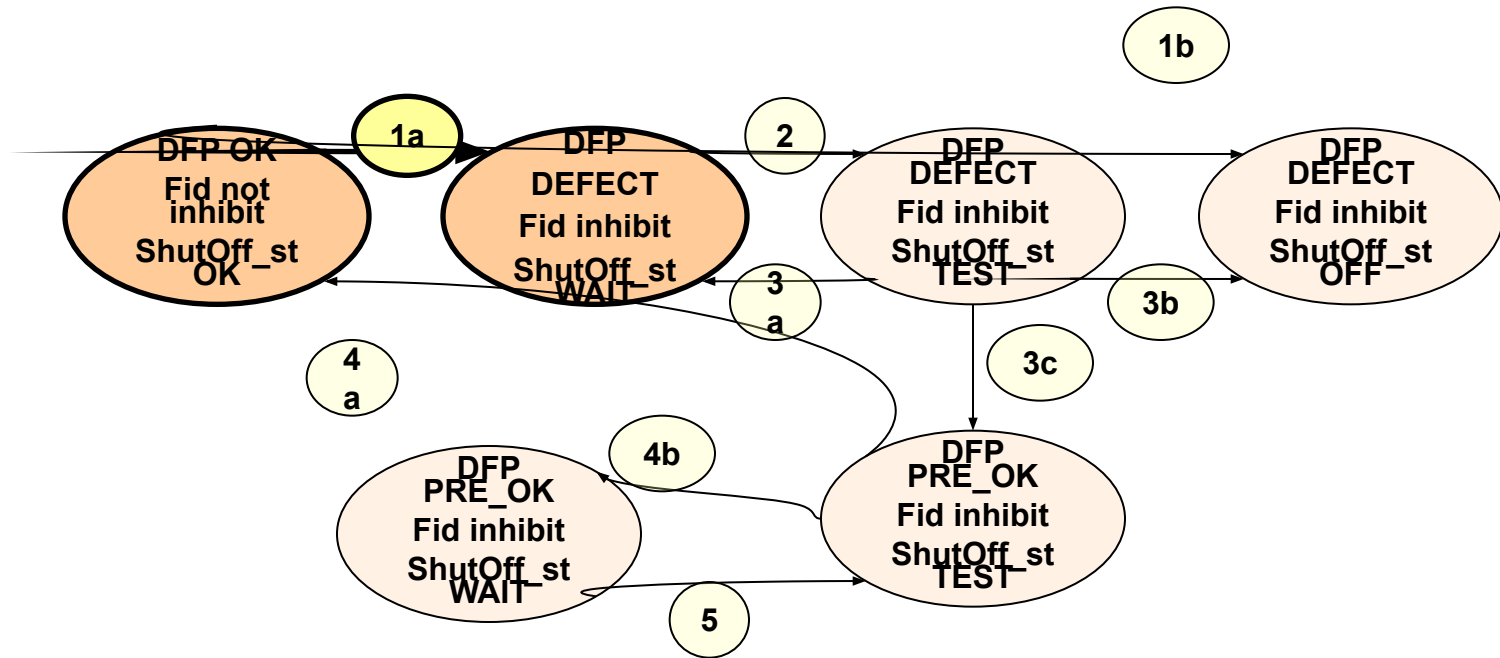

Transition 1a: "Switch-On-Test" is applied ($\text{InjVlv_numTest_C} > 0$).

An error is detected, debounced and Shut Off Fid (Fid_Bnk%ShOffTest/Fid_Cyl%ShOffTest) is activated; the applied cylinders will be disconnected and the system stays in Shut Off state "WAIT".

State machine of the diagnosis Shut Off (2)

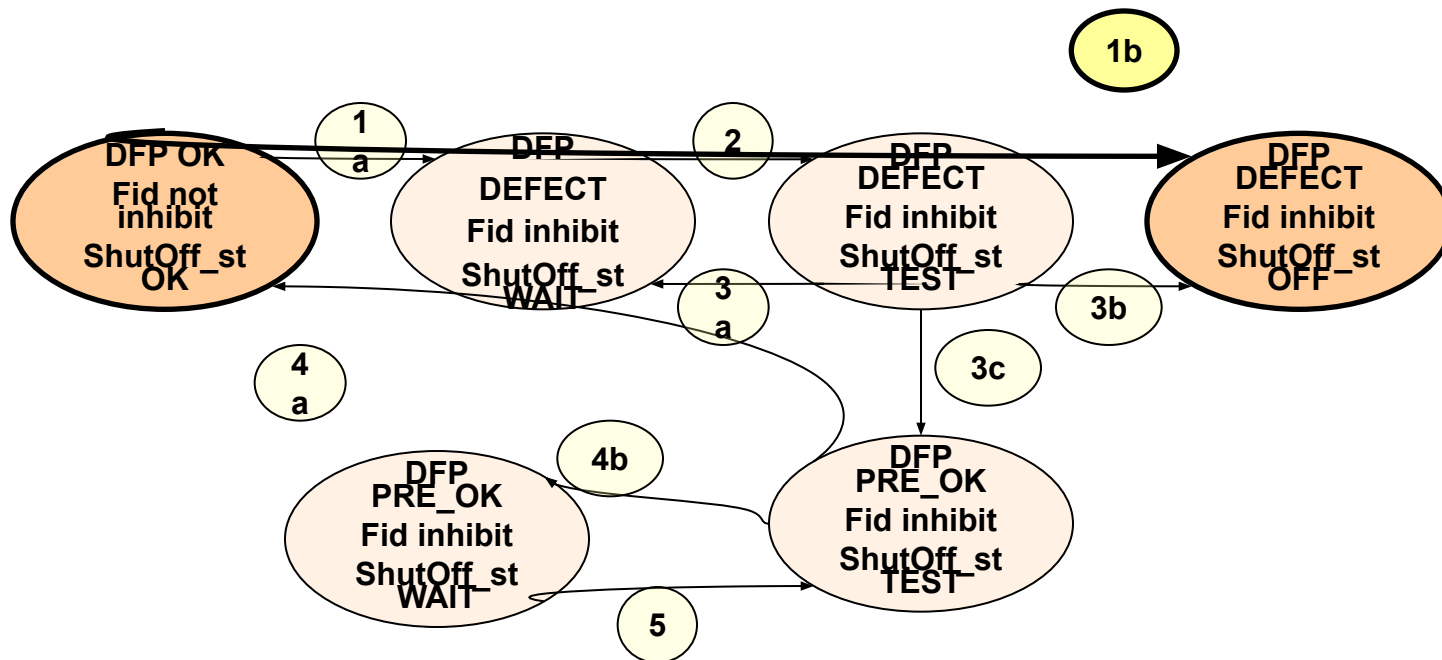

Transition 1b: "Switch-On-Test" is not applied ($\text{InjVlv_numTest_C} = 0$).

An error is detected, debounced and Shut Off Fid (Fid_Bnk%ShOffTest/Fid_Cyl%ShOffTest) is activated; the applied cylinders will be permanent disconnected (Shut Off state "OFF").

State machine of the diagnosis Shut Off (3)

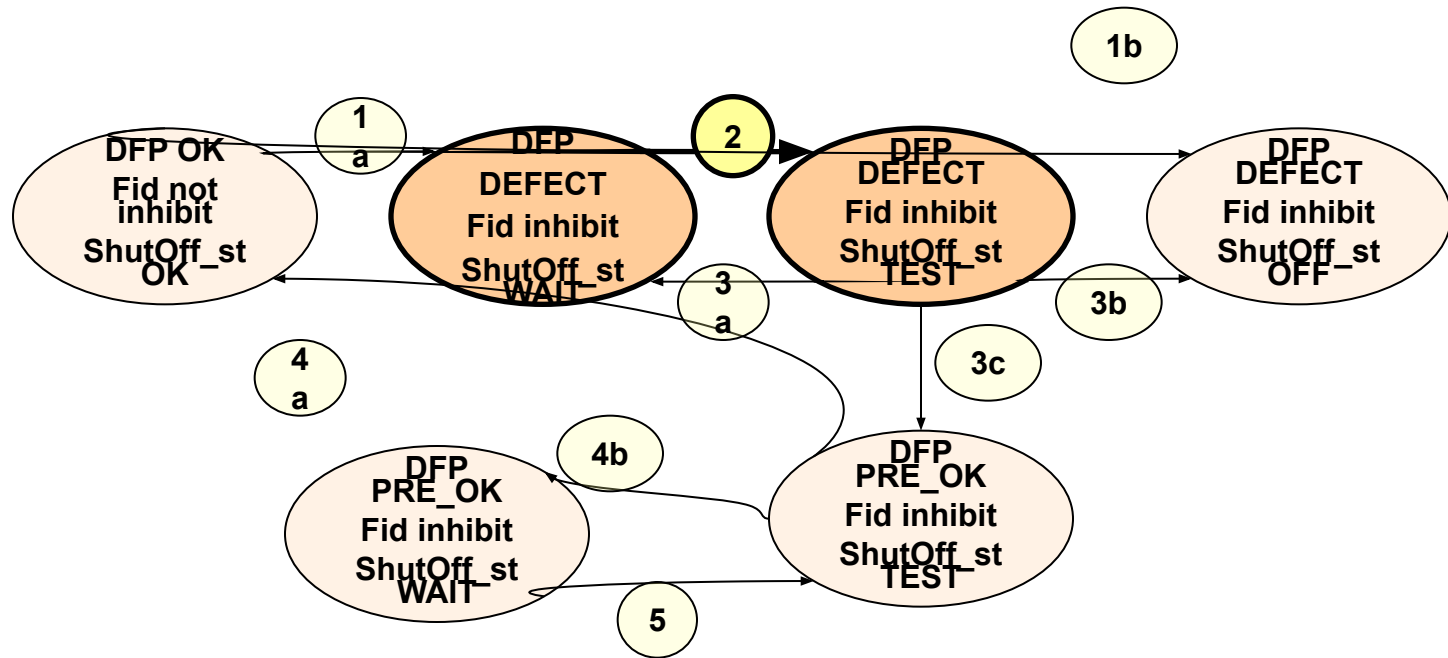

Transition 2: After a determined number of injections ($\text{InjVlv_numWaitInj_C}$), the cylinder is connected again and it is checked to see if the error has disappeared: Shut Off state "TEST". This test is performed a determinate number of injections ($\text{InjVlv_numTestInj_C}$).

State machine of the diagnosis Shut Off (4)

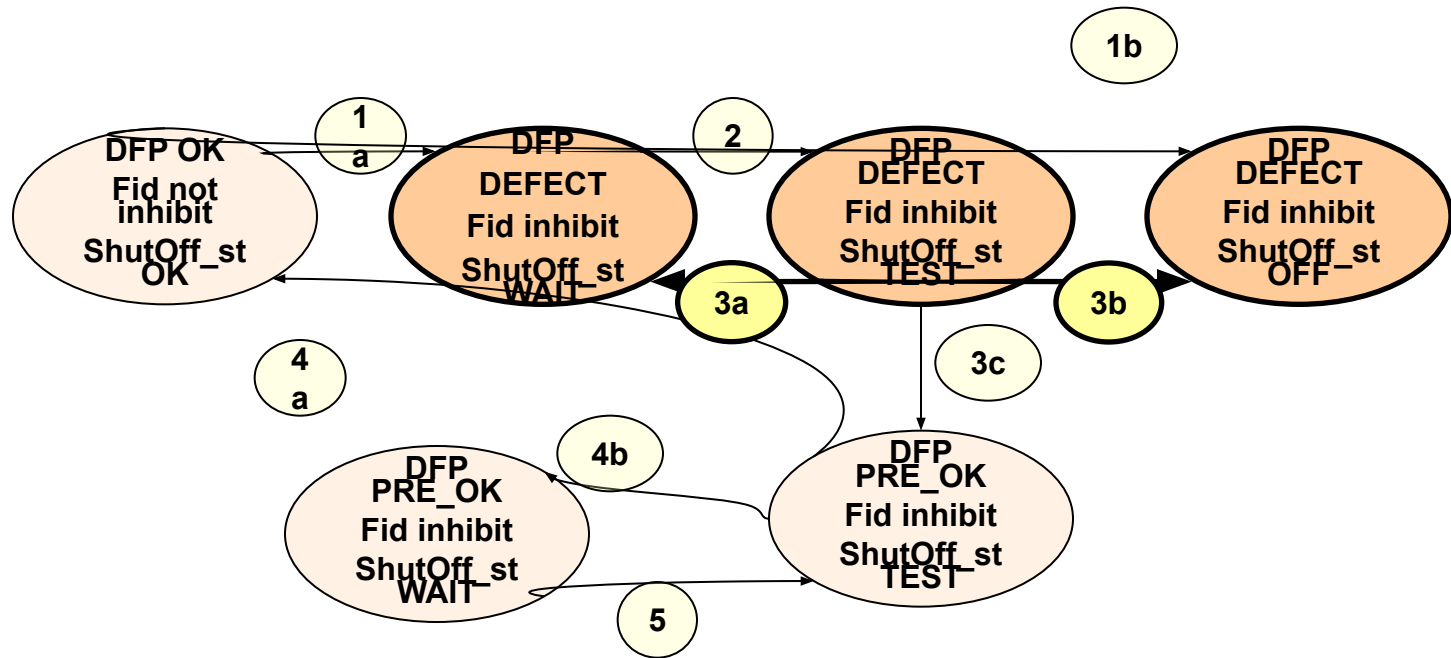

Transition 3a: If after the test injections the error remains, the cylinder/bank is set to Shut Off state "WAIT" again.

Transition 3b: The operations of "TEST" and "WAIT" are performed InjViv_numTest_C times. In case these attempts are fulfilled and the error has not disappeared, the cylinder/bank is set to state finally off (Shut Off state "OFF").

State machine of the diagnosis Shut Off (5)

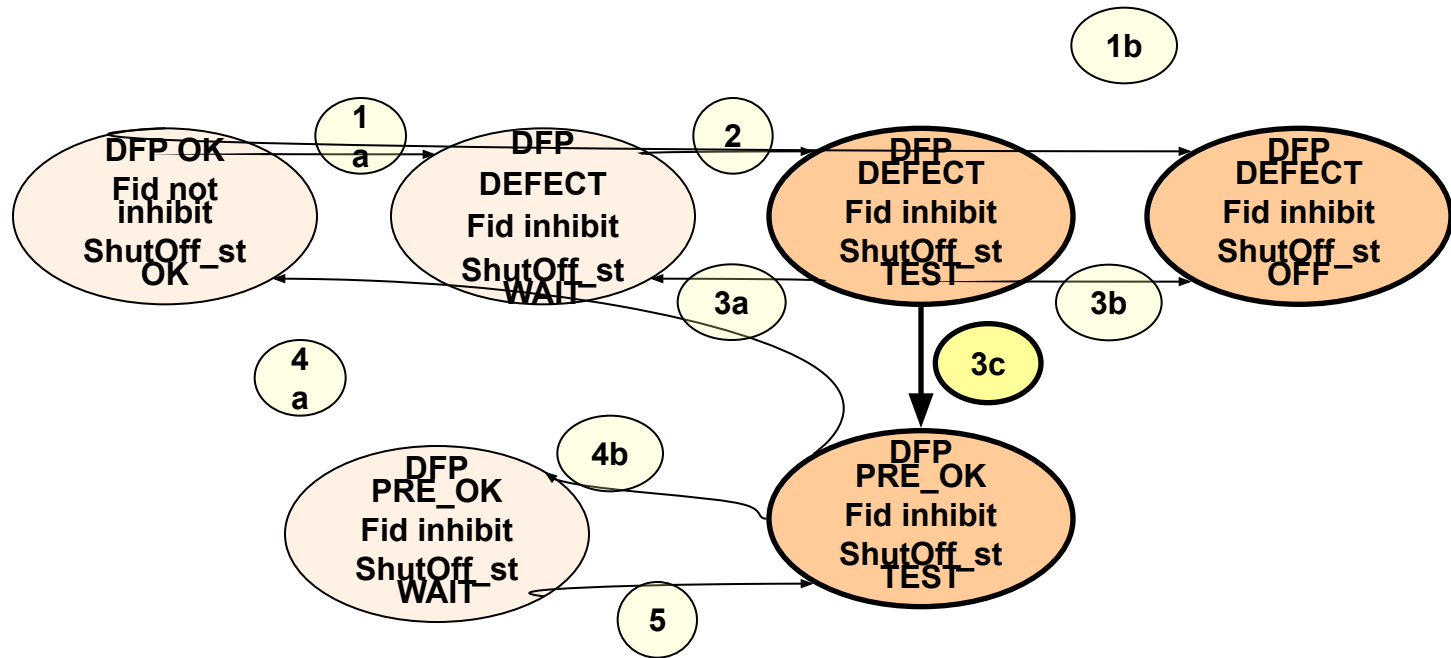

Transition 3c: If the error has disappeared, healing-debounce is started

State machine of the diagnosis Shut Off (6)

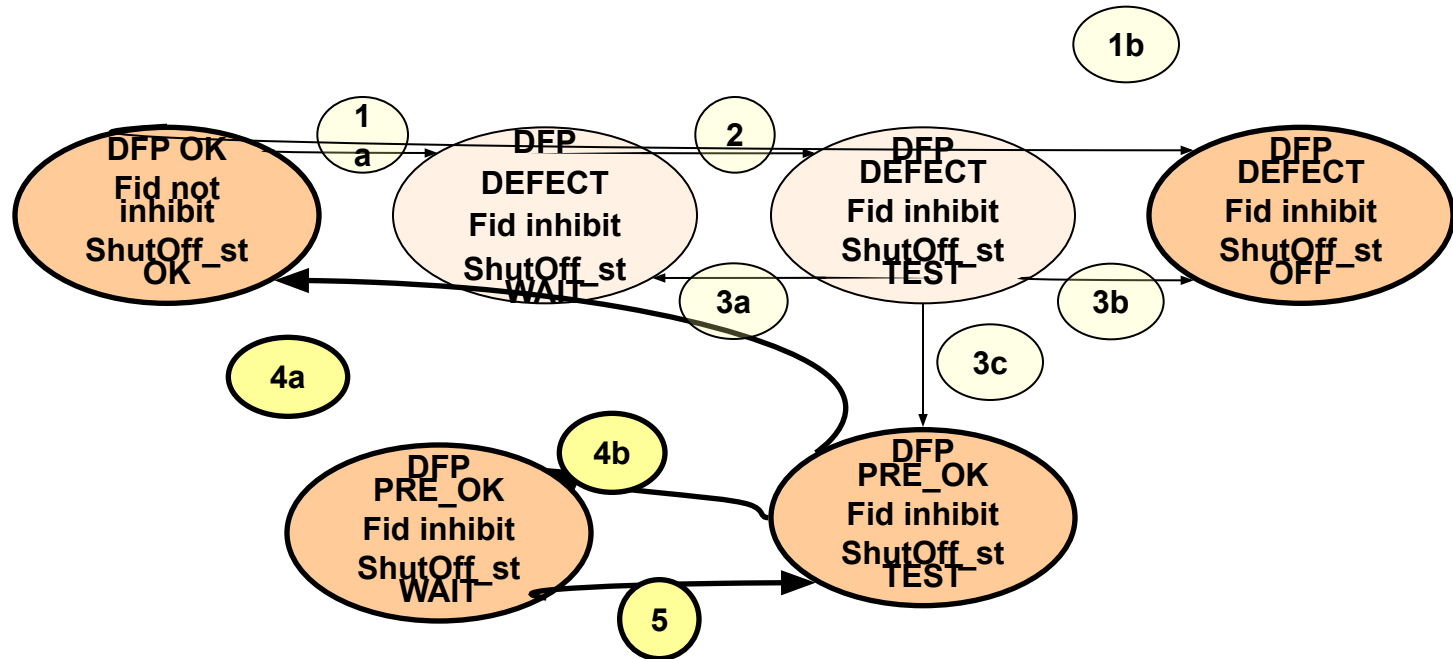

Transition 4a: Healing-debounce is completed.

Transition 4b: Healing-debounce is not completed. System waits for the next test injections.

Transition 5: New test injection are performed.

Diagnosis Shut Off debouncing

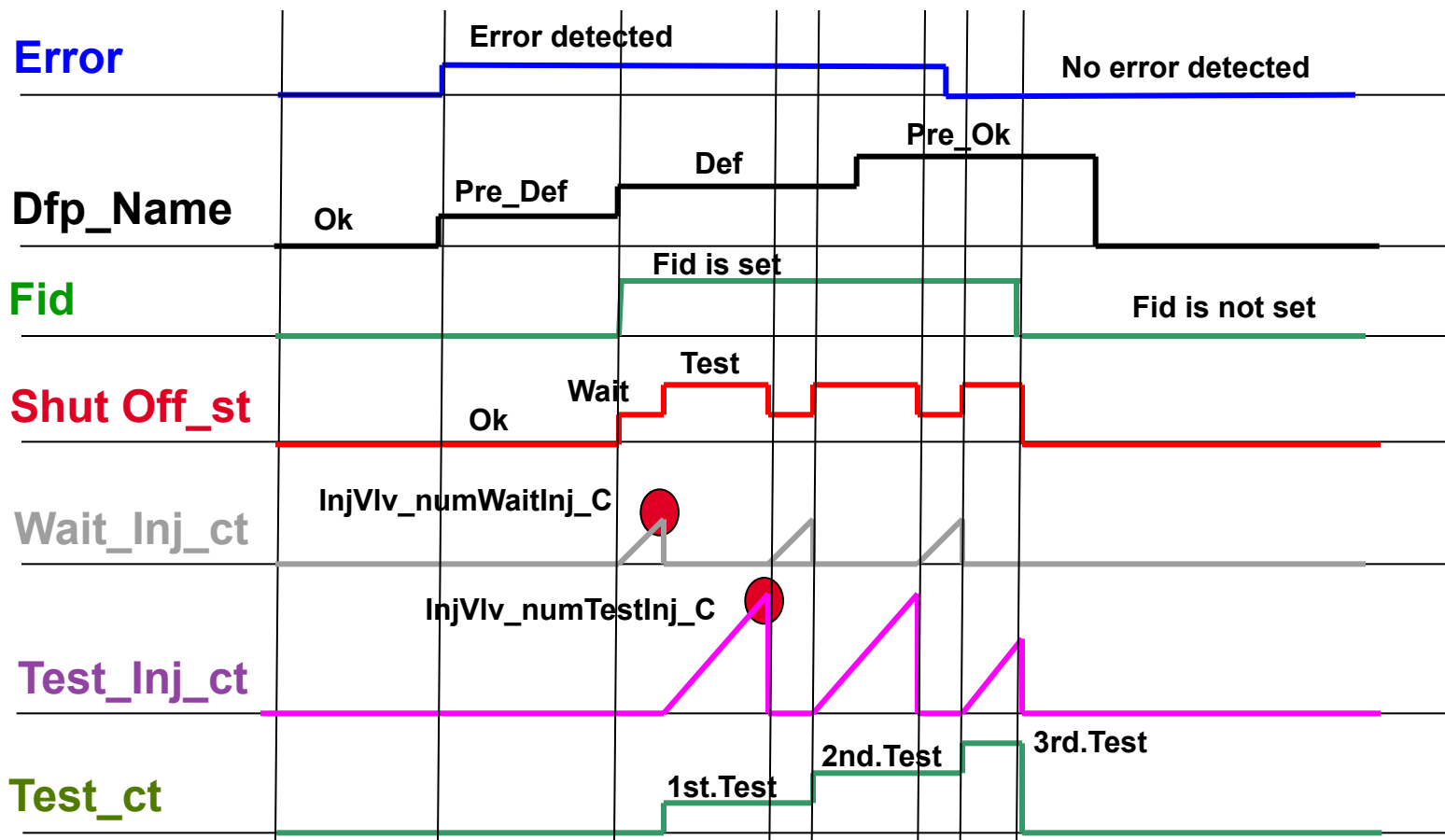

Shut Off Application

- ▣ **Open Circuit** → **No Shut Off** is needed for a cylinder-open load. If more than `InjVlv_numNoLoadCylMax_C` cylinders have open load, a complete Shut Off is performed
- ▣ **Short Circuit High Side to Low Side** → **Cylinder or Bank Shut Off**. SCHSLS is cylinder specific detectable, and has no influence in the other cylinders of the same bank. At least a cylinder Shut Off is required, but depending of the project a bank Shut Off can be applied.
- ▣ **Short Circuit High Side to Battery - Short Circuit High Side to Ground** → **Bank Shut Off**; SCHSBA and SCHSGN are bank errors.
- ▣ **Short Circuit Low Side to Battery - Short Circuit Low Side to Ground** → **Bank Shut Off**; Both of the errors have an influence to the other cylinders of the same bank
- ▣ **Unclassifiable Bank Error - Unclassifiable Cylinder Error** → **Bank Shut Off**

InjVlv_MonShOff Labels

Application parameters

- InjVlv_numWaitInj_C (Number of wait injections)
- InjVlv_numTestInj_C (Number of test injections)
- InjVlv_numTest_C (Number of tests)
 - For Series InjVlv_numTest_C = 0

Output values

- InjVlv_stMonDia (Shut Off activated)
- InjVlv_stInjCharShOff (Injection Shut Off)

Agenda

- Vision general of diagnosis
- Solenoid Valve Monitoring of CR- & U-System
- Outcomes of the Short Circuits
- Solenoid Valve Monitoring Shut Off
- **Application procedure**
 - Application procedure
 - Measure procedure in Truck
 - Breakout Box
 - Application process
- Actual platform application
- Peculiarity 8 Cylinder software with multiplexer

Application procedure

- Hardware application hints
- Measure process in Labor:
 - Perform the errors at the injector side
 - Perform the errors at the ECU side
 - Measures on different cylinders and banks under different operating conditions (low idle, high revolution number, error applied before terminal 15 is activated, short circuit with high and low ohm resistance, different battery voltages)
- Measure process in Truck:
 - Perform the errors at the injector side
 - Measures on different cylinders and banks under different operating conditions (low idle, high revolution number, error applied before terminal 15 is activated, short circuit with high and low ohm resistance)
- Measure analysis and compare with labor measurements and simulation
- Calculate the Pattern and Select Matrix
- Validation of the application

Measure procedure in Truck

- Ensure before the beginning of the measurements, that your vehicle has a series wiring harness and all powerstage SSDs are project-specific correctly calibrated. This covers e.g. the current profile, booster voltage, etc.
- **The measurements are worthless without pre-series-production hardware or with defective calibration of the SSDs, because the CY33x error registers are dependent on it.**
- Carry out the vehicle measurements with a breakout box.
- **Do not use any wiring harness adapter!**
- With help of the breakout box, the following errors have to be generated on each cylinder:
 - No Load (NL)
 - Short circuit High-Side to Ground (SCHSGN)
 - Short circuit High-Side to Battery (SCHSBA)
 - Short circuit Low-Side to Ground (SCLSGN)
 - Short circuit Low-Side to Battery (SCLSBA)
 - Short circuit High-Side to Low-Side (SCHSLS)
- The measurements should be repeated more than once (for e.g. three times) under different operating conditions (Low idle, Low-idle with increased rotational speed, Start of engine with the error).

Breakout Box

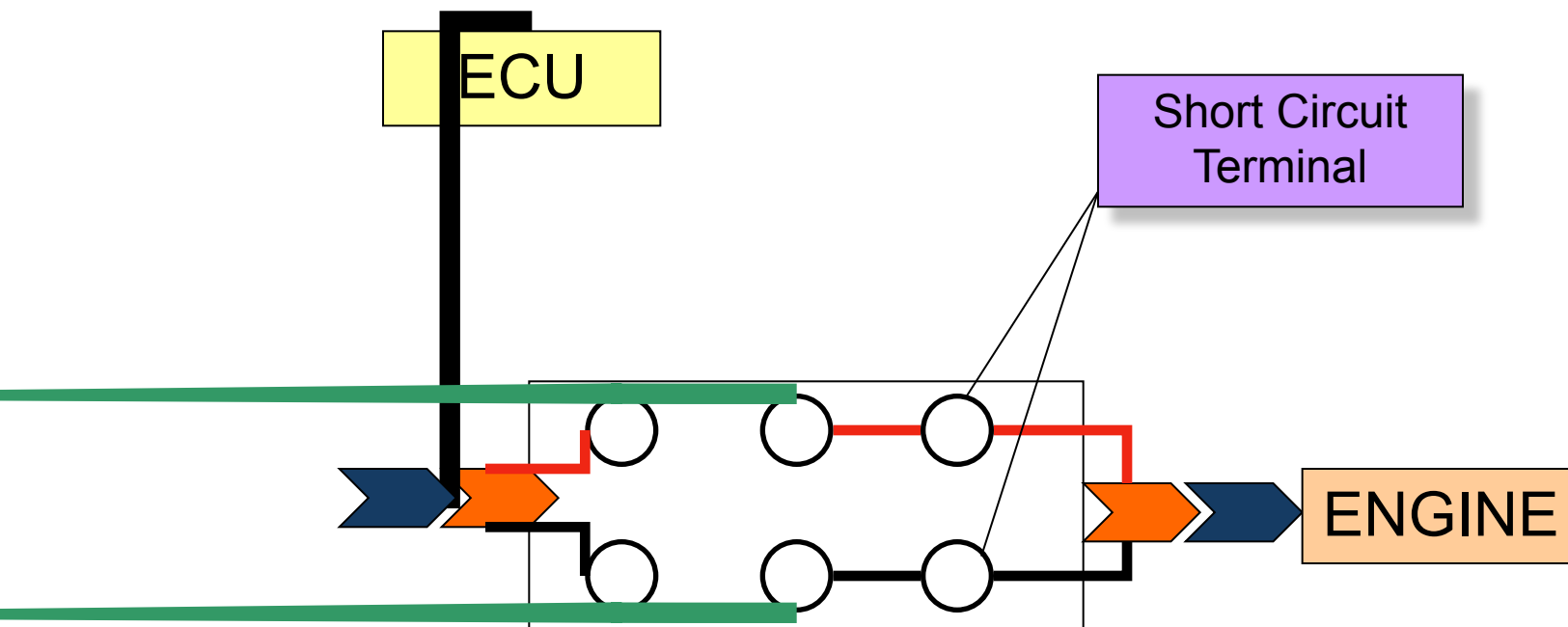

Breakout Box – Open Circuit

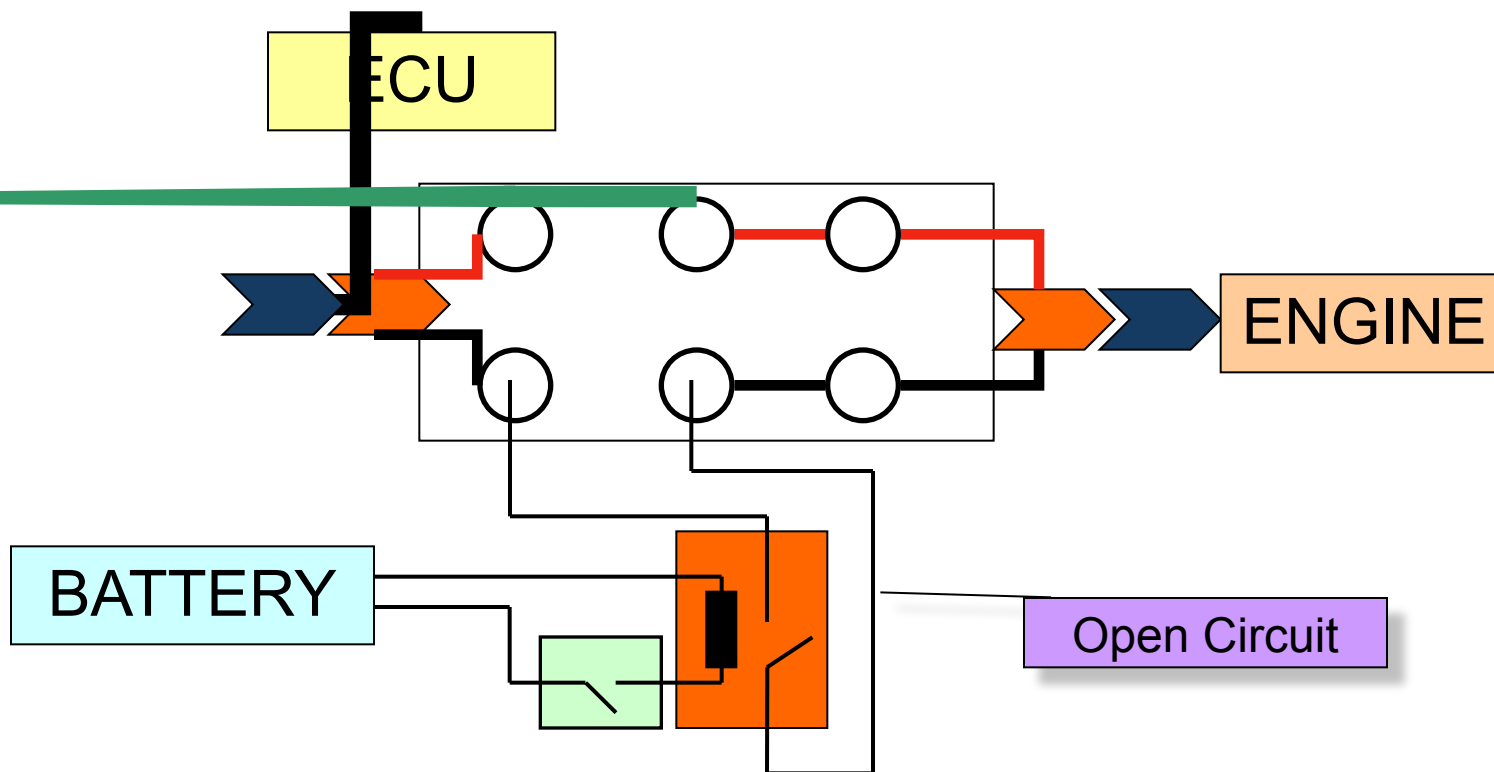

Breakout Box – Short Circuit to Battery/Ground

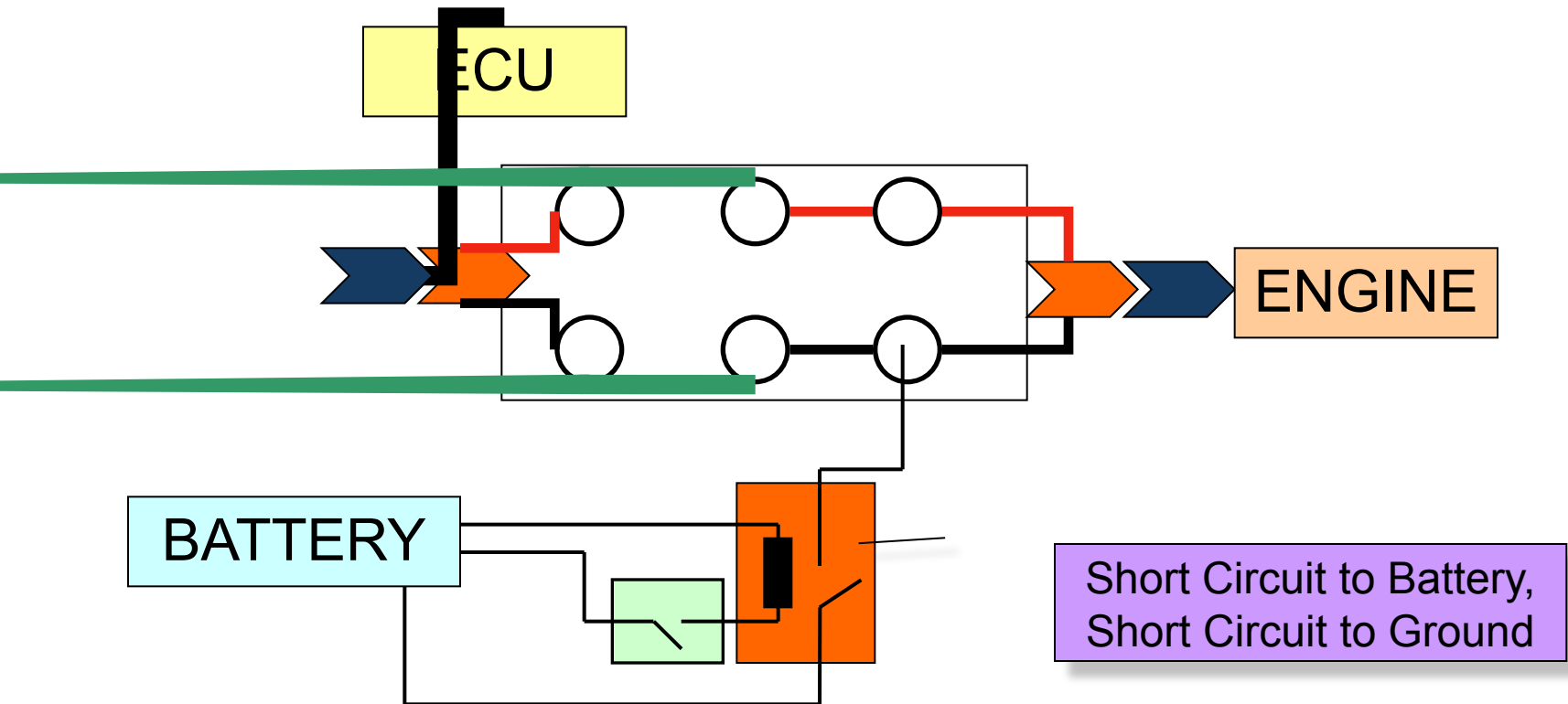

Breakout Box – Short Circuit High Side - Low Side

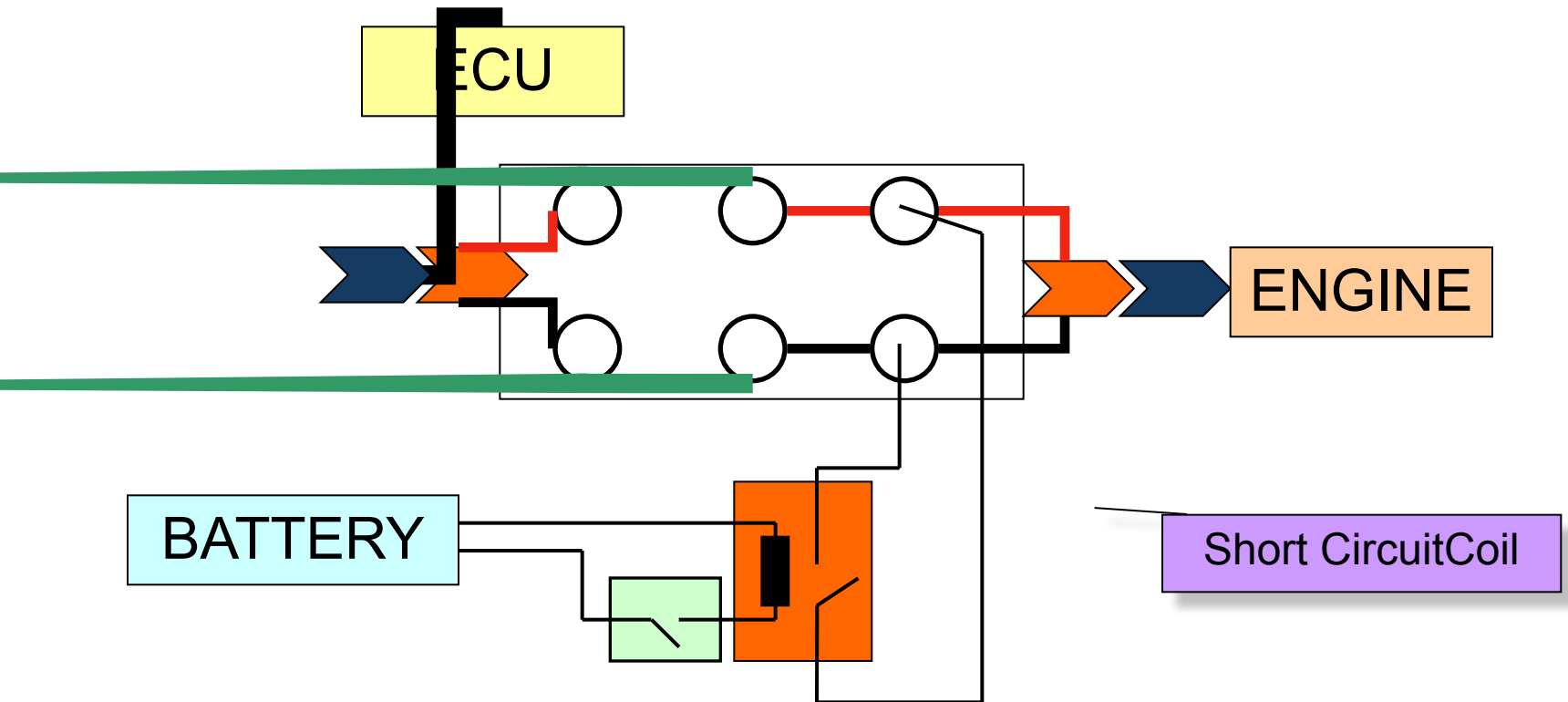

Application process

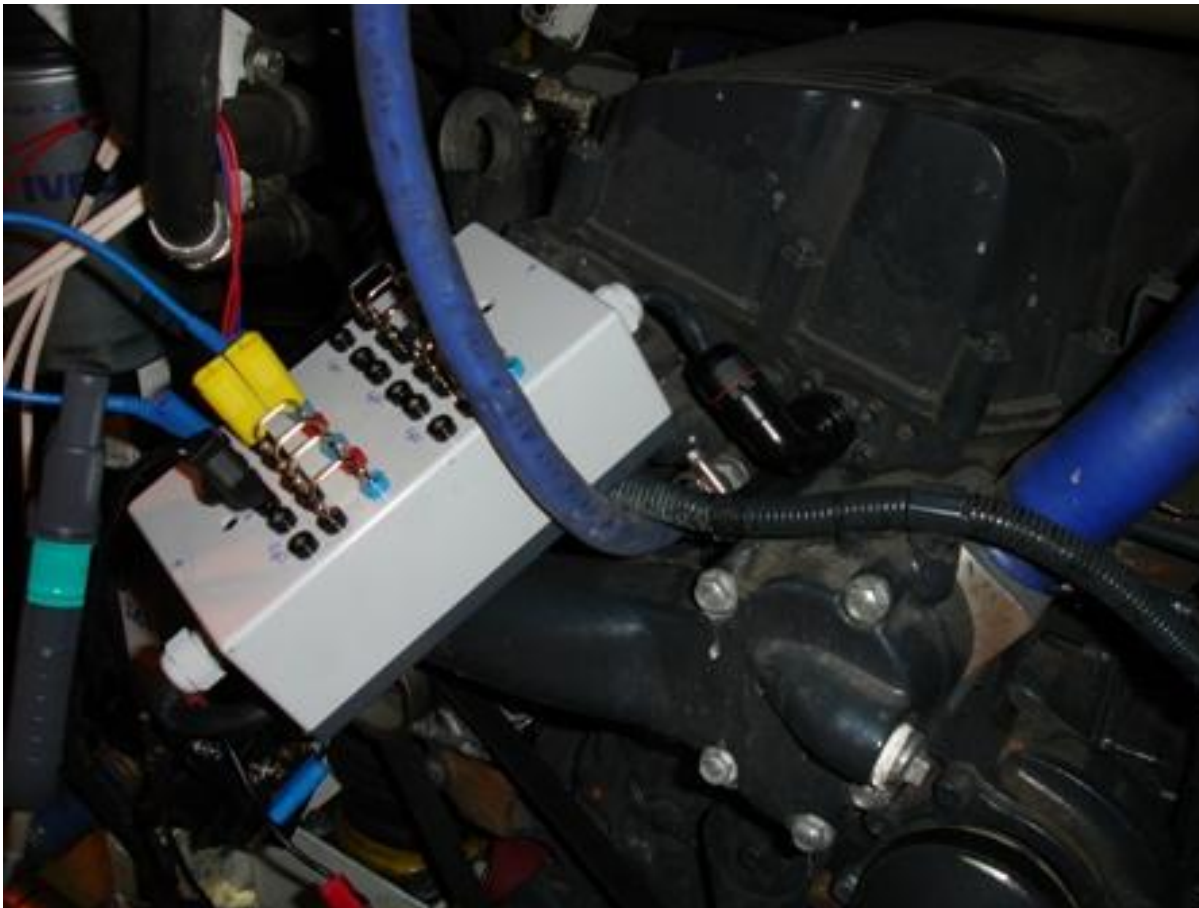

Application process



Diesel Systems

Manuel Gil - DS/ECP4 | 15/03/2008 | © Robert Bosch GmbH 2007. All rights reserved, also regarding any disposal, exploitation, reproduction, editing, distribution, as well as in the event of applications for industrial property rights.



BOSCH

Application process



Application process

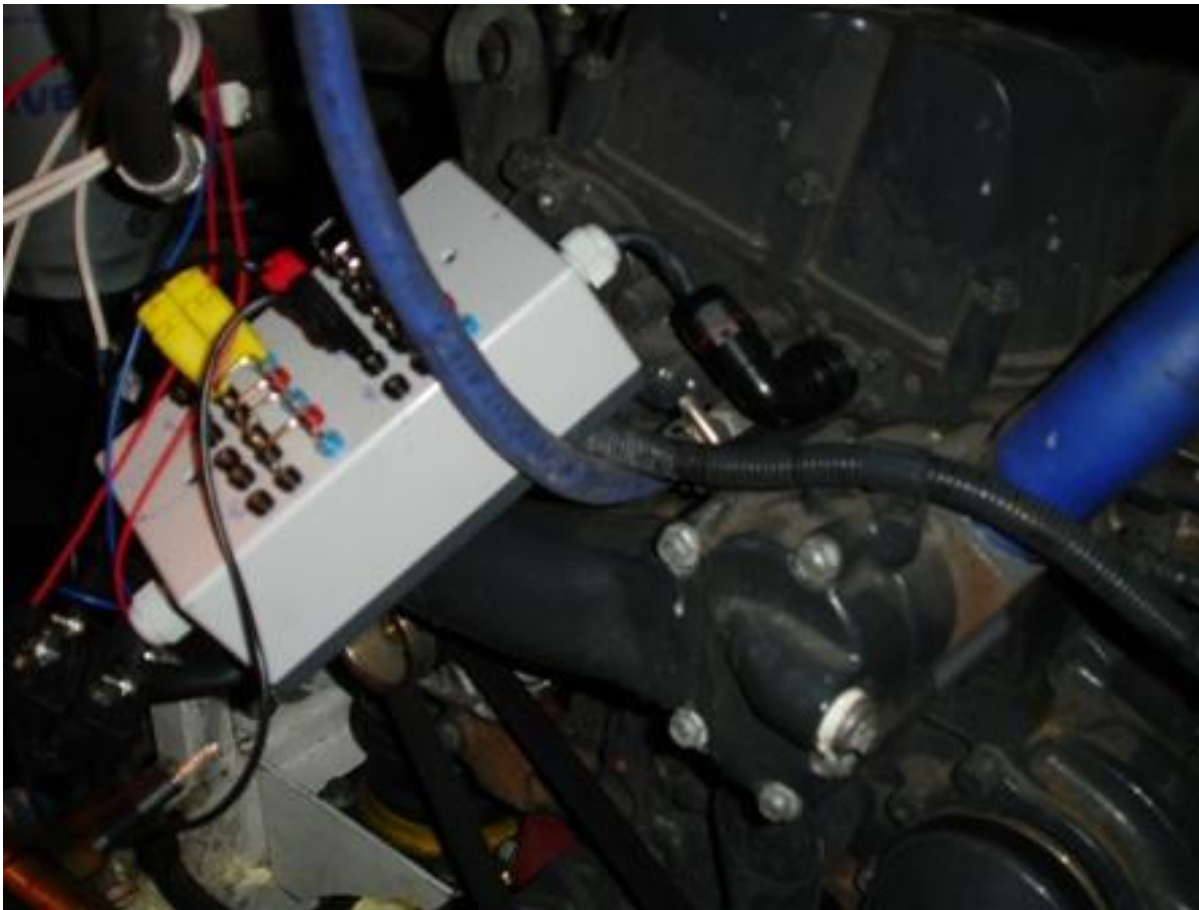

Application process



Application process



Application process



Application process



Application process



Agenda

- Vision general of diagnosis
- Solenoid Valve Monitoring of CR- & U-System
- Outcomes of the Short Circuits
- Solenoid Valve Monitoring Shut Off
- Application procedure
- **Actual platform application**
 - Dependence Classifiable-Unclassifiable Errors
 - Application in Detail
 - Overview of different diagnosis strategies
- Peculiarity 8 Cylinder software with multiplexer

Dependence Classifiable-Unclassifiable Errors (1)

To avoid a double fault memory entry of an error, and also for a wrong reaction for an error (for example if the pattern recognition sequence detects a Classifiable Cylinder Error (CCE) and an Unclassifiable Bank Error for the same physical error), the following relation in the application of the ThresholdDebounceToDefect parameter for Classifiable Bank/Cylinder Errors (CBE/CCE) and Unclassifiable Bank/Cylinder Error (UBE/UCE) errors must be consider:

ThresToDefectUBE ≥ ThresToDefectUCE > ThresToDefectCBE > ThresToDefectCCE

Dependence Classifiable-Unclassifiable Errors (2)

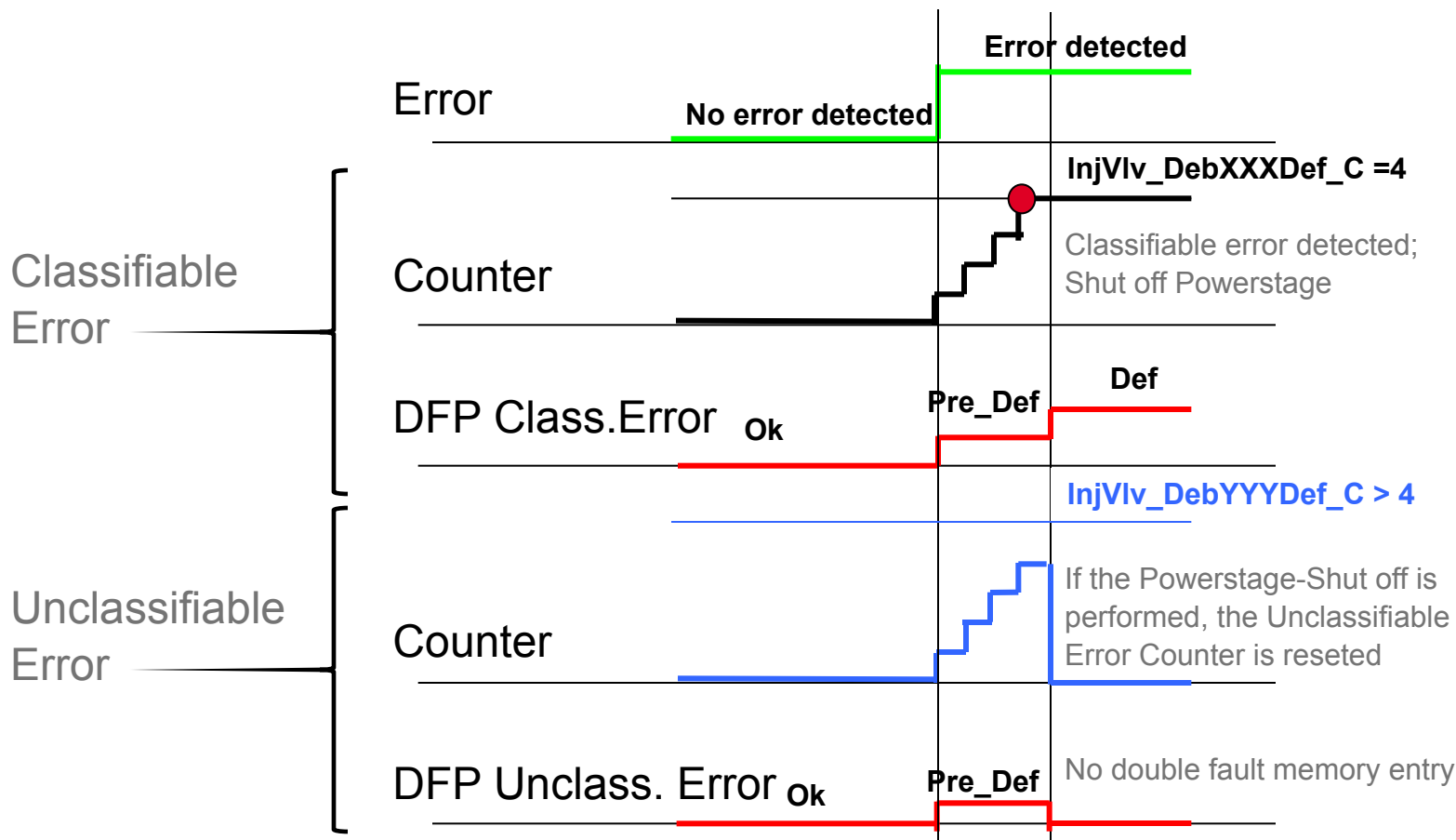

Application in Detail (1)

Open Circuit

Overcurrent in active Cylinder	No
Overcurrent in inactive Cylinder	No
Undesired quantity at active Cylinder	No
Undesired quantity at inactive Cylinder	No
Error Detection	Cylinder Specific
DFP	Dfp_InjVlvCyl%B.SIG
Healing	Healing possible
Debounce to Def	InjVlv_DebCylB2Def_C = 3
Debounce to Ok	InjVlv_DebCylB2Ok_C = 0
Diagnosis Reaction	Only if more than InjVlv_numNoLoadCylMax_C open circuits

Application in Detail (2)

Open Circuit – Dfp_InjVlv_Cyl%B.SIG

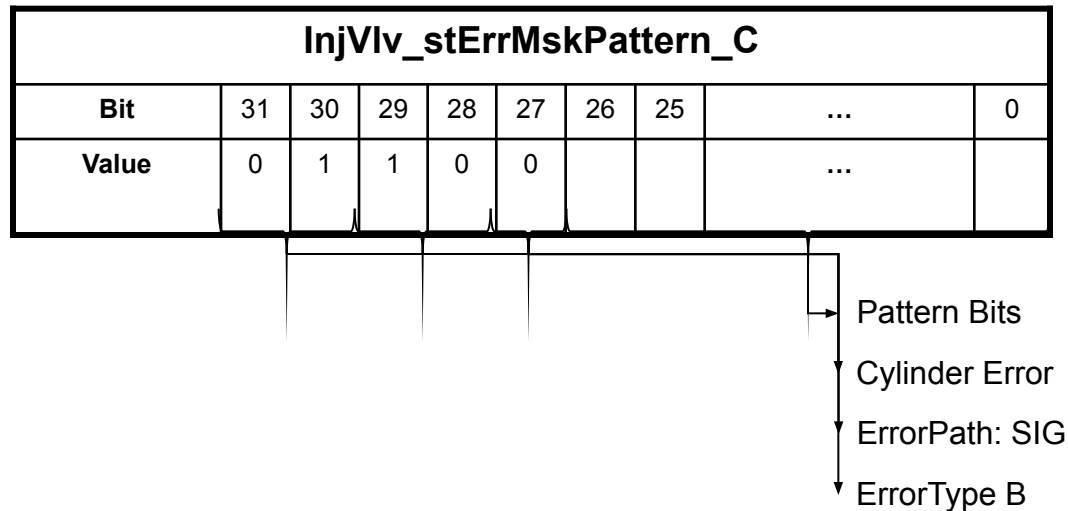

Application in Detail (3)

Short Circuit High Side to Battery

Overcurrent in active Cylinder	~ 5A / 10 us until powerstage Shut Off (Boosterovercurrent)
Overcurrent in inactive Cylinder	No
Undesired quantity at active Cylinder	No
Undesired quantity at inactive Cylinder	No
Error Detection	Bank Specific No difference with SCHSGN
DFP	Dfp_InjVlvBnk%A.MAX
Healing	No Healing possible
Debounce to Def	InjVlv_DebBnkA0Def_C = 5
Debounce to Ok	InjVlv_DebBnkA0Ok_C = 65535
Diagnosis Reaction	Bank Shut Off

Application in Detail (5)

Short Circuit High Side to Ground

Overcurrent in active Cylinder	No
Overcurrent in inactive Cylinder	No
Unwished quantity at active Cylinder	No
Unwished quantity at inactive Cylinder	No
Error Detection	Bank Specific No difference with SCHSBA
DFP	Dfp_InjVlvBnk%A.MAX
Healing	No Healing possible
Debounce to Def	InjVlv_DebBnkA0Def_C = 5
Debounce to Ok	InjVlv_DebBnkA0Ok_C = 65535
Diagnosis Reaction	Bank Shut Off



Application in Detail (4)

Short Circuit High Side – Dfp_InjVlv_Bnk%A.MAX

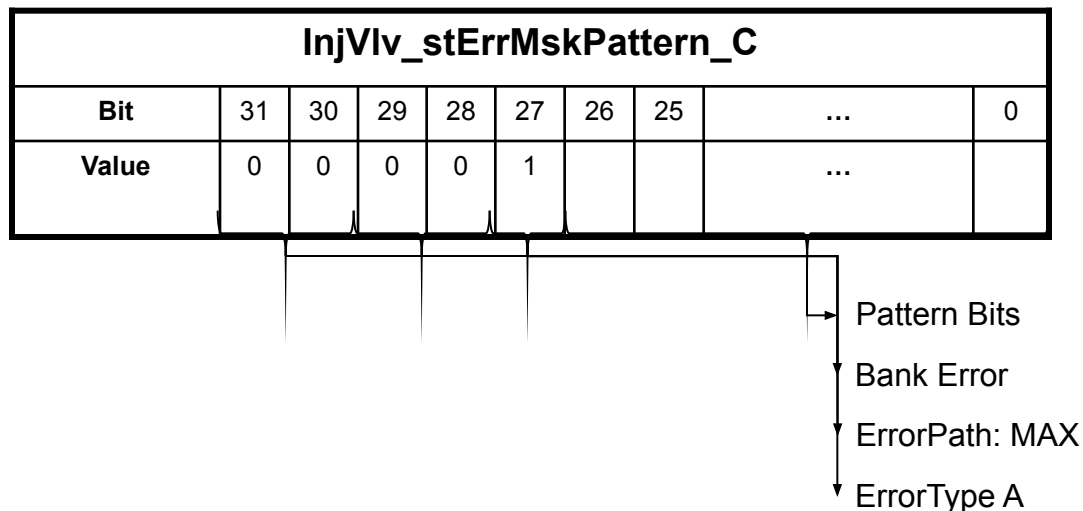

Application in Detail (6)

Short Circuit Low Side to Battery

Overcurrent in active Cylinder	Only in Boosterphase if Low Battery
Overcurrent in inactive Cylinder	No
Unwished quantity at active Cylinder	No
Unwished quantity at inactive Cylinder	Yes
Error Detection	Bank Specific
DFP	Dfp_InjVlvCyl%A.MAX
Healing	No Healing possible
Debounce to Def	InjVlv_DebCylA0Def_C = 3
Debounce to Ok	InjVlv_DebCylA0Ok_C = 65535
Diagnosis Reaction	Bank Shut Off



Application in Detail (7)

Short Circuit Low Side to Battery – Dfp_InjVlv_Cyl%A.MAX

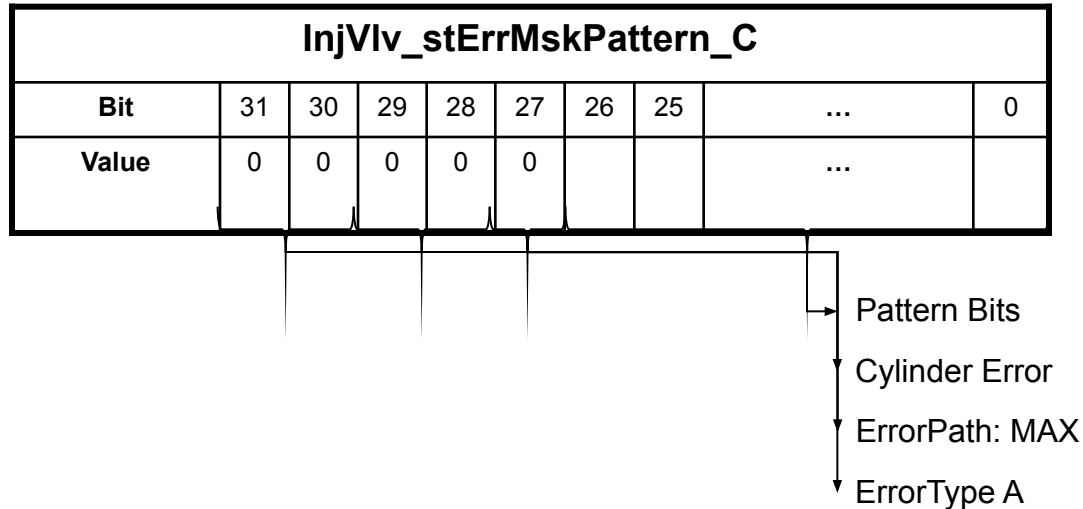

Application in Detail (8)

Short Circuit Low Side to Ground

Overcurrent in active Cylinder	No
Overcurrent in inactive Cylinder	Yes
Unwished quantity at active Cylinder	Yes
Unwished quantity at inactive Cylinder	Yes
Error Detection	Bank Specific
DFP	Dfp_InjVlvBnk%A.MIN
Healing	No Healing possible
Debounce to Def	InjVlv_DebBnkA1Def_C = 5
Debounce to OK	InjVlv_DebBnkA1Ok_C = 65535
Diagnosis Reaction	Bank Shut Off



Application in Detail (9)

Short Circuit Low Side to Ground - Dfp_InjVlv_Bnk%A.MIN

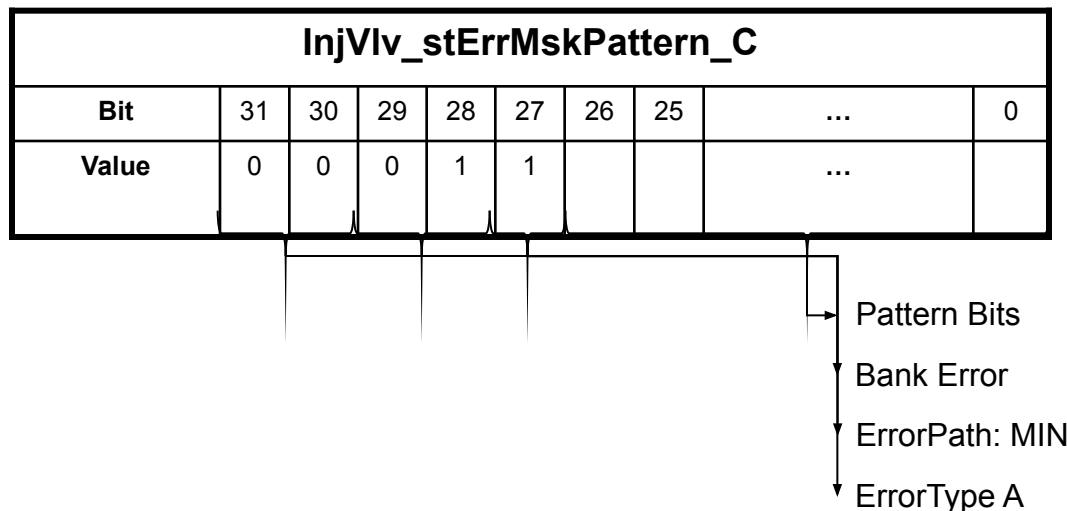

Application in Detail (10)

Short Circuit High Side to Low Side

Overcurrent in active Cylinder	Yes, but no influence to the injector
Overcurrent in inactive Cylinder	No
Unwished quantity at active Cylinder	No
Unwished quantity at inactive Cylinder	No
Error Detection	Cylinder Specific
DFP	Dfp_InjVlvCyl%A.SIG
Healing	No Healing possible
Debounce to Def	InjVlv_DebCylA2Def_C = 3
Debounce to OK	InjVlv_DebCylA2Ok_C = 65535
Diagnosis Reaction	Bank Shut Off

Application in Detail (11)

Short Circuit High Side to Low Side – Dfp_InjVlv_Cyl%A.SIG

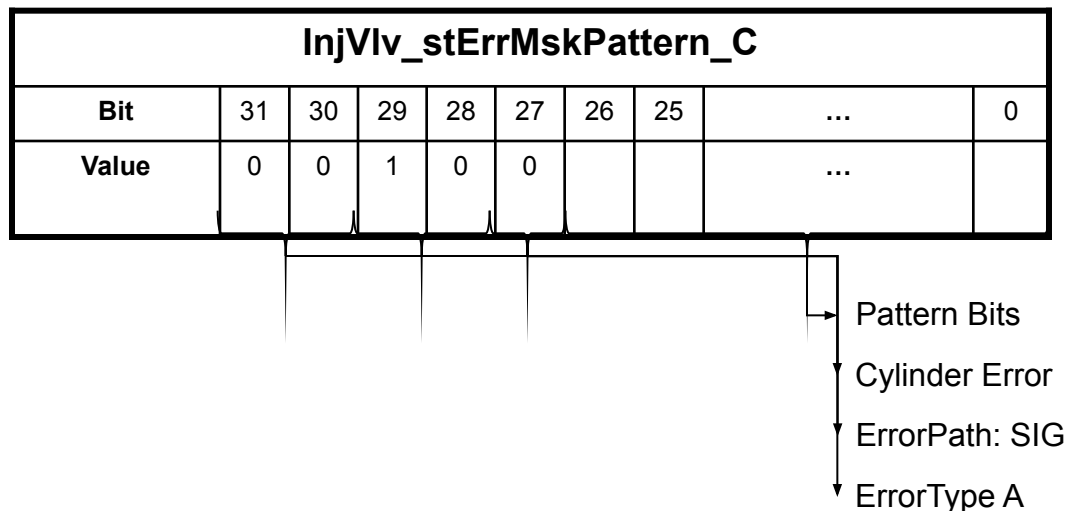

Application in Detail (12)

Unclassifiable Cylinder Error – Dfp_InjVlv_Cyl%A.NPL

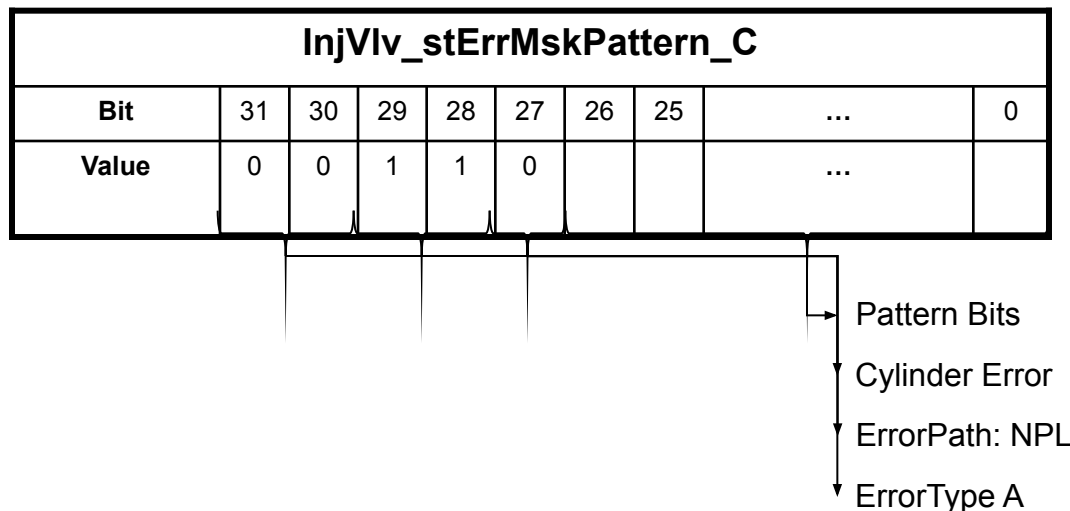

InjVlv_DebCylA3Def_C = 8
InjVlv_DebCylA3Ok_C = 65535

Application in Detail (13)

Unclassifiable Cylinder Error – Dfp_InjVlv_Cyl%A.NPL

InjVlv_stErrMskPattern_C [1]																												
0	0	1	1	0	0	0	0	0	0	0	0	0	0	0	0	0	0	0	0	0	0	0	0	0	0	0	0	0
3				0				0				0				0				0				0				

InjVlv_stErrMskSelect_C [1]																														
0	0	0	0	0	0	0	0	0	0	0	0	0	0	0	0	0	0	0	0	0	0	0	0	0	0	1	1	1	1	1
0				0				0				0				0				1				F						



Application in Detail (14)

Unclassifiable Bank Error – Dfp_InjVlv_Bnk%A.NPL

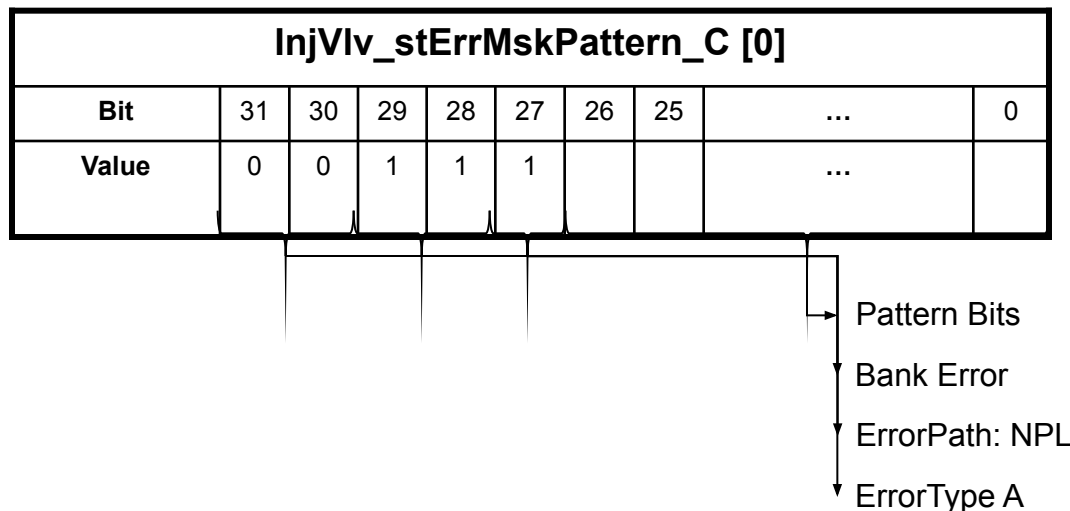

`InjVlv_DebBnkA3Def_C = 9`

`InjVlv_DebBnkA3Ok_C = 65535`

Application in Detail (15)

Unclassifiable Bank Error – Dfp_InjVlv_Bnk%A.NPL

InjVlv_stErrMskPattern_C [0]																												
0	0	1	1	1	0	0	0	0	0	0	0	0	0	0	0	0	0	0	0	0	0	0	0	0	0	0	0	0
3			8				0		0		0		0		0		0											

InjVlv_stErrMskSelect_C [0]																												
0	0	0	0	0	0	0	0	0	0	0	0	0	0	0	0	0	0	1	1	0	1	1	0	0	0	0	0	0
0		0		0		0		1		B		0		0														



Application in Detail (16)

Fast Decay Error – Dfp_InjVlv_Cyl%B.MAX - **ONLY U-System**

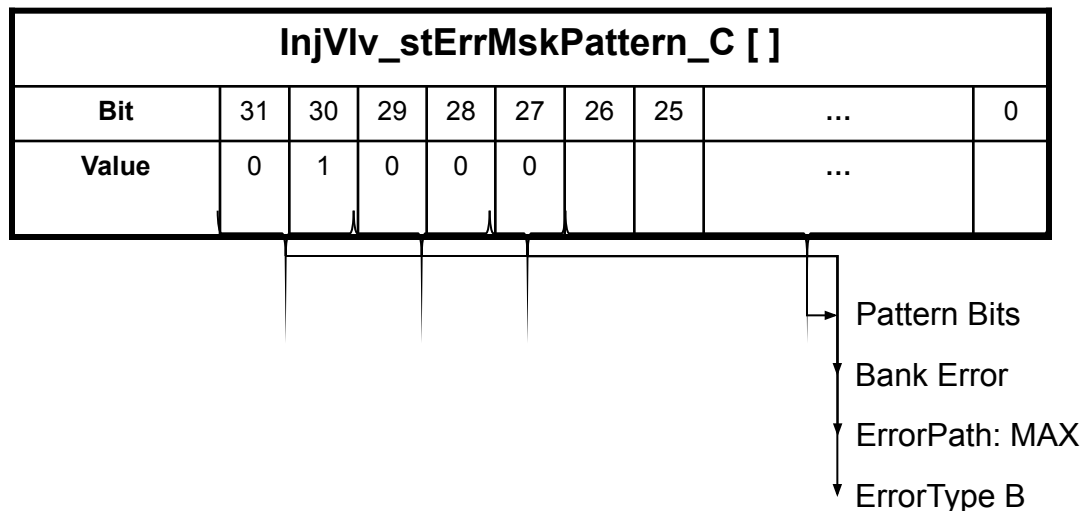

InjVlv_DebCylB0Def_C = 5
InjVlv_DebCylB0Ok_C = 65535

Application in Detail (17)

Fast Decay Error – Dfp_InjVlv_Cyl%B.MAX - **ONLY U-System**

InjVlv_stErrMskPattern_C																															
0	1	0	0	0	0	0	0	0	0	0	0	0	0	0	0	0	0	0	0	0	0	0	0	0	0	1	0	0	0	0	
4				0				0				0				0				0				1				0			

InjVlv_stErrMskSelect_C																															
0	0	0	0	0	0	0	0	0	0	0	0	0	0	0	0	0	0	1	1	0	1	1	0	0	0	1	1	1	1	1	
0				0				0				0				1				B				1				F			



Application in Detail (18)

Booster Time-out Error – Dfp_InjVlv_Bnk%A.SIG - **ONLY CR-System**

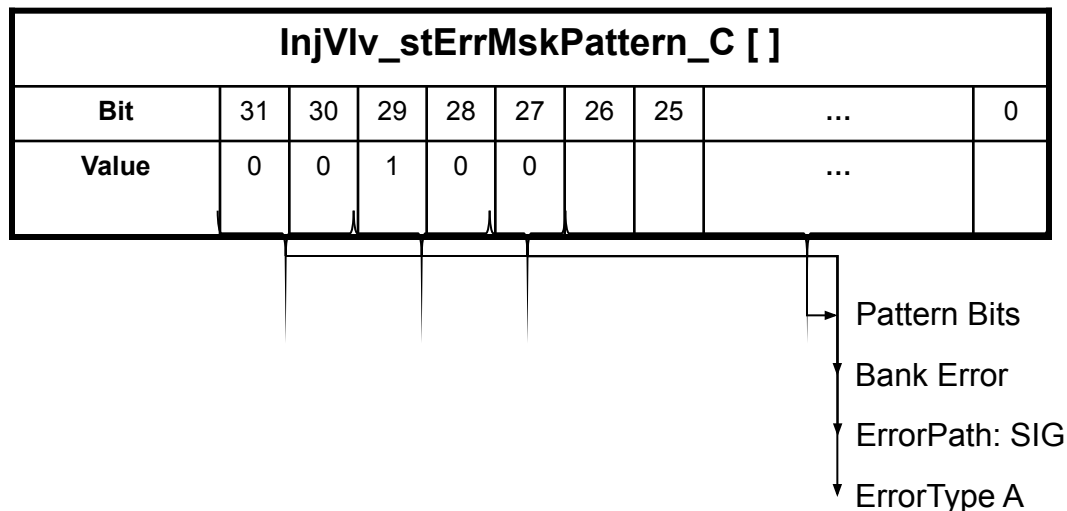

InjVlv_DebBnkB2Def_C = 3
InjVlv_DebBnkB2Ok_C = 65535

Application in Detail (19)

Booster Time-out Error – Dfp_InjVlv_Bnk%A.SIG - **ONLY CR-System**

InjVlv_stErrMskPattern_C																															
0	0	1	0	1	0	0	0	0	0	0	0	0	0	0	0	0	0	1	0	0	0	0	0	0	0	0	0				
2				8				0				0				1				0				0				0			

InjVlv_stErrMskSelect_C																															
0	0	0	0	0	0	0	0	0	0	0	0	0	0	0	0	0	0	1	1	0	1	1	0	0	0	1	1	1	1		
0				0				0				0				1				B				1				F			

Application in Detail (20)

Dfp_InjVlvBnk%A U-System					
Path	Error	ToDef	ToOK	Diagnose reactions *	System reactions *
.MAX	SCHS	5	65535	Fid_Bnk\$ShutOffTest	Fid_RunUpTst Fid_FBC Fid_BipNoDetBnk\$
.MIN	SCLSGN	5	65535		
.SIG	Not Used	65535	0		
.NPL	UBE	9	65535		

* Minimum Requirement; Other Reactions could be applied

Application in Detail (21)

Dfp_InjVlvBnk%A CR- System					
Path	Error	ToDef	ToOK	Diagnose reactions	System reactions
.MAX	SCHS	5	65535	Fid_Bnk\$ShutOffTest Fid_SetBstErr_SIG	Fid_RunUpTst Fid_FBC Fid_CmbChb Fid_HpTst
.MIN	SCLSGN	5	65535		
.SIG	Booster Time-out Error	3	65535		
.NPL	UBE	9	65535		

Application in Detail (22)

Dfp_InjVlvBnk%B UI & CR					
Path	Error	ToDef	ToOK	Diagnose reactions	System reactions
.MAX	Not Used	65535	0		
.MIN	Not Used	65535	0		
.SIG	Not Used	65535	0		
.NPL	Not Used	65535	0		

Application in Detail (23)

Dfp_InjVlvCyl%A UI					
Path	Error	ToDef	ToOK	Diagnose reactions	System reactions
.MAX	SCLSBA	3	65535	Fid_Bnk\$ShutOffTest	Fid_RunUpTst Fid_FBC Fid_BipNoDetBnk\$
.MIN	Not Used	65535	0		
.SIG	SCHSLS	3	65535		
.NPL	UCE	8	65535		

Application in Detail (24)

Dfp_InjVlvCyl%A CR-System					
Path	Error	ToDef	ToOK	Diagnose reactions	System reactions
.MAX	SCLSBA	3	65535	Fid_Bnk\$ShutOffTest	Fid_RunUpTst Fid_FBC Fid_CmbChb Fid_HpTst
.MIN	Not Used	65535	0		
.SIG	SCHSLS	3	65535		
.NPL	UCE	8	65535		

Application in Detail (25)

Dfp_InjVlvCyl%B UI					
Path	Error	ToDef	ToOK	Diagnose reactions	System reactions
.MAX	FDE	5	65535	Fid_Bnk\$ShutOffTest_MAX Fid_BipNoDetBnk\$_MAX	Fid_RunUpTst Fid_FBC
.MIN	Not Used	65535	0		
.SIG	OC	3	0	Fid_BipNoDetCyl%_SIG	
.NPL	Not Used	65535	0		

Application in Detail (26)

Dfp_InjVlvCyl%B CR					
Path	Error	ToDef	ToOK	Diagnose reactions	System reactions
.MAX	Not Used	65535	0		Fid_RunUpTst Fid_FBC Fid_CmbChb Fid_HpTst
.MIN	Not Used	65535	0		
.SIG	OC	3	0		
.NPL	Not Used	65535	0		

Overview of different diagnosis strategies

Car	Truck
Complete Shut Off for each error except open circuit Maximal 1 cylinder with open circuit	Bank Shut Off
CR System	U System
No Split Injection	No FDE for Split Injection

EDC16	EDC17
Error-Typ detected (if possible)	Error-Typ not detected

Agenda

- Vision general of diagnosis
- Solenoid Valve Monitoring of CR- & U-System
- Outcomes of the Short Circuits
- Solenoid Valve Monitoring Shut Off
- Application procedure
- Actual platform application
- **Peculiarity 8 Cylinder software with multiplexer**
 - 8 Cylinder software with multiplexer
 - 8 Cylinder software with MUX – U System

8 Cylinder software with multiplexer

- The 8 cylinders powerstage is realized with one CY332B, which can handle 6 powerstages directly. The both additional powerstages are realized through a Multiplexer (MUX) in the gate activation circuit of the LS-FET's of Cyl.12 and Cyl. 22
- The MUX is controlled by the TPU.
- For the diagnosis of powerstages 12 (Bank 1, Cyl 2) and 14 is used only a common error register (the same occurs for powerstages 22 and 24) because there are available only 6 fault memories to register to the cylinder specific diagnosis error information. Therefore two registers are covered twice. The diagnosis information of the first activated MUX-powerstage would become, while activation of the second MUX-powerstage, the diagnosis information of both powerstage by logical OR.
- Therefore no cylinders specific recognition can be performed.

8 Cylinder software with multiplexer

□ **CR-System:**

- Change in HWE → InjVlv_Mon becomes SPI cylinder specific information for each cylinder

□ **U-System:**

- By a cylinder disconnection will be recognizable the error cylinder specific.
- To execute a cylinder-specific recognition on the MUX powerstages, after cylinder specific error detection in the MUX powerstages, one of them is switched off. If the error disappears, the error was in the switched off cylinder. If the error continues, the error was in the not switched off cylinder.
- While a "double error" on the MUX powerstages is debounced, one of the MUX powerstages is switched off for some injections. After the disconnection, the debounce-error-counter of the cylinder with the error has a higher value than the counter of the cylinders without error, and therefore is set this cylinder first in defect status



Overview of Diagnosis

8 Cylinder software with MUX – U System

No Error at Deactivated Cylinder

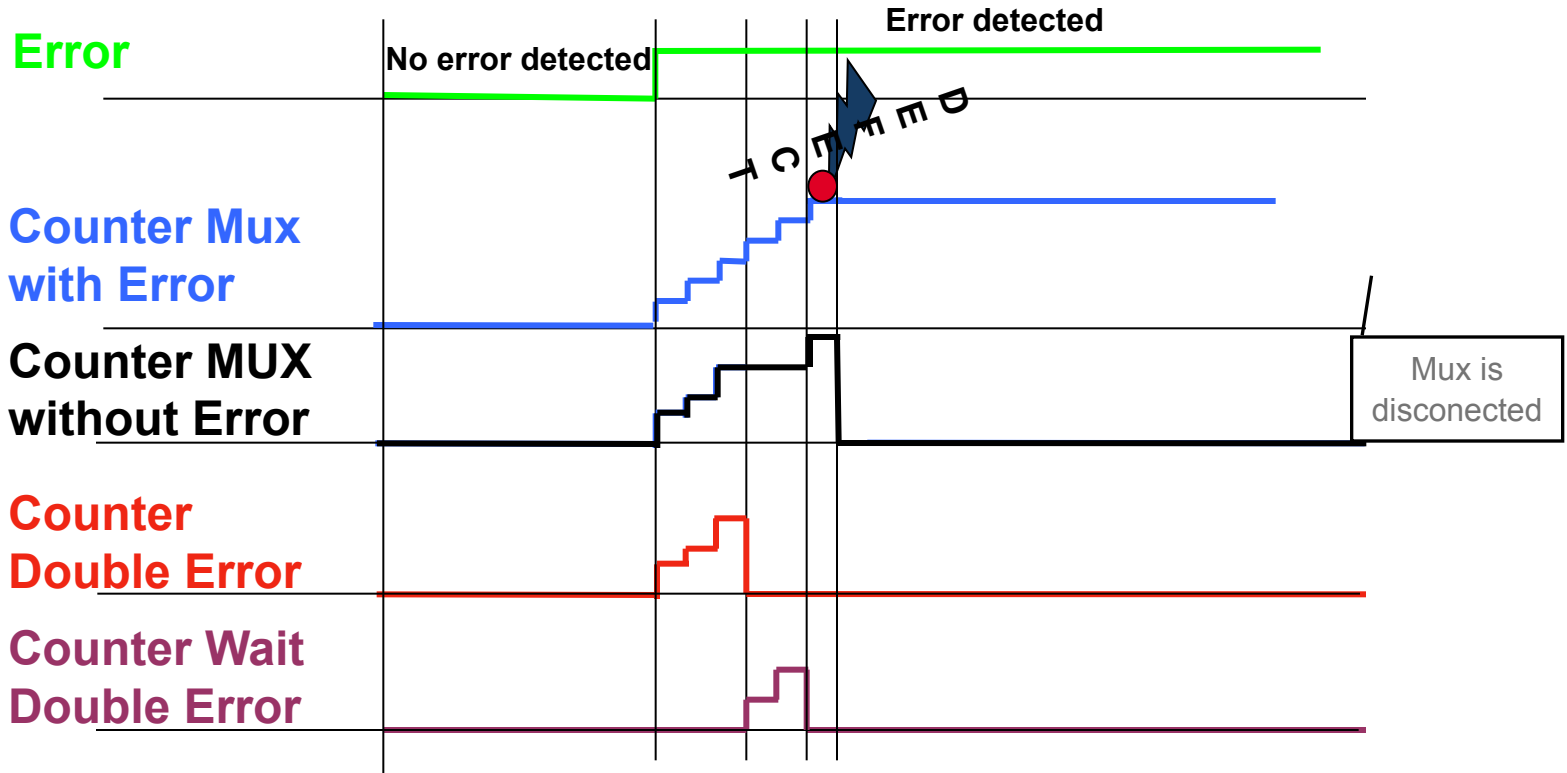

Overview of Diagnosis

8 Cylinder software with MUX – U System

Error at Deactivated MUX

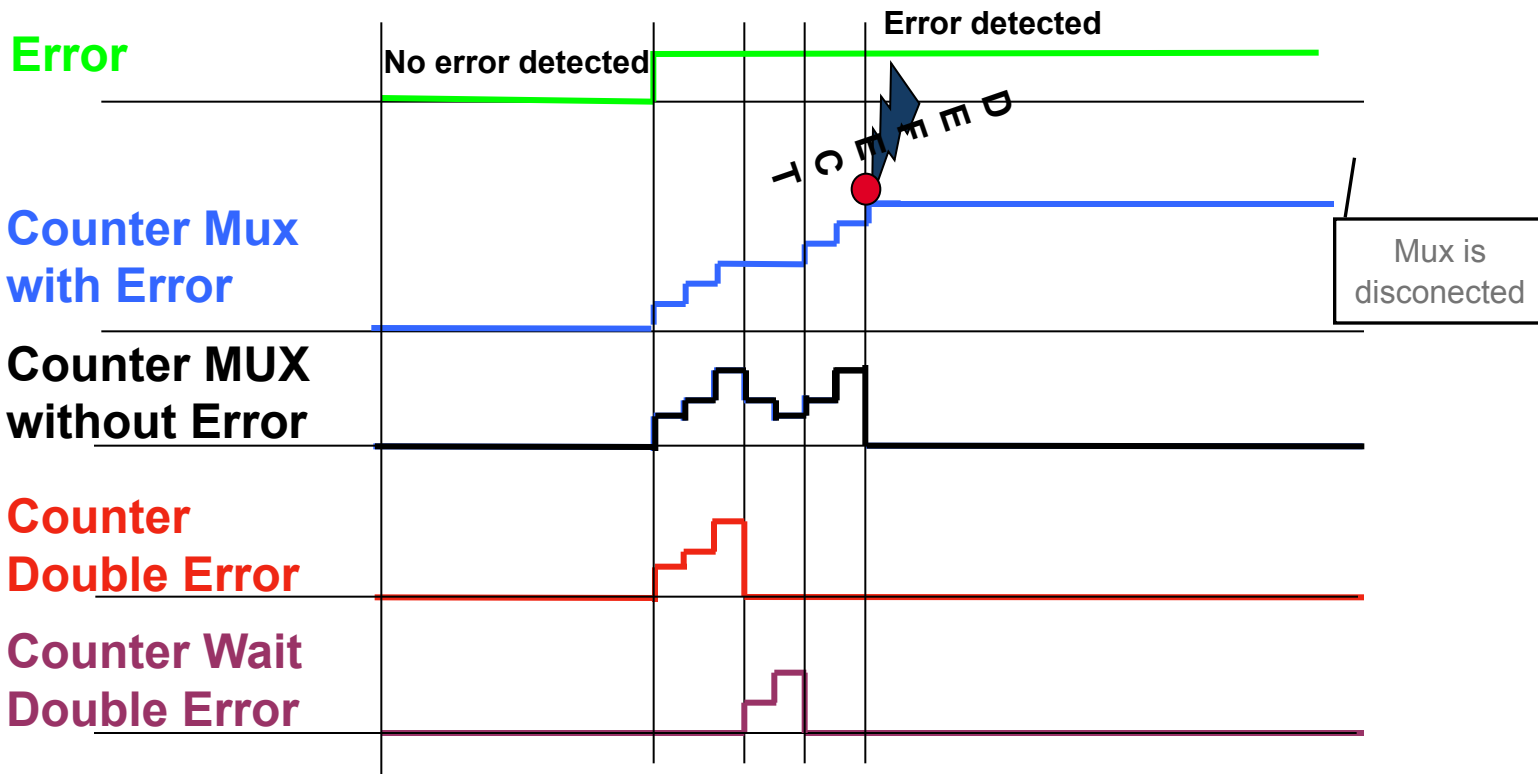

8 Cylinder software with MUX – U System

Application parameters

- ▣ **InjVlv_numMaxDoubleError_C** (Number of injections with double detected before deactivation of one cylinder)
- ▣ **InjVlv_numWaitDoubleError_C**(Number of injections with a deactivated cylinder)

Output values

- ▣ **InjVlv_stTestMuxBnk%** (State of Multiplexed cylinder Shut Off to avoid double error)

Overview of Diagnosis

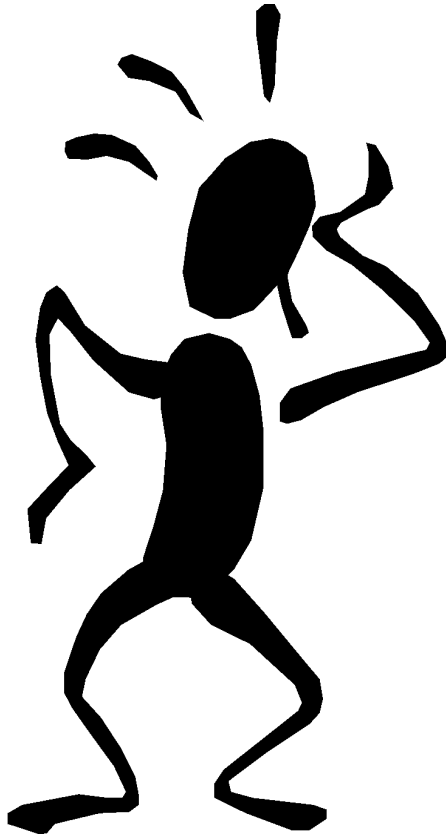

Diesel Systems

Manuel Gil - DS/ECP4 | 15/03/2008 | © Robert Bosch GmbH 2007. All rights reserved, also regarding any disposal, exploitation, reproduction, editing, distribution, as well as in the event of applications for industrial property rights.



BOSCH

Error Debouncing

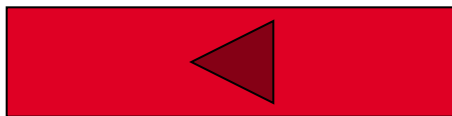
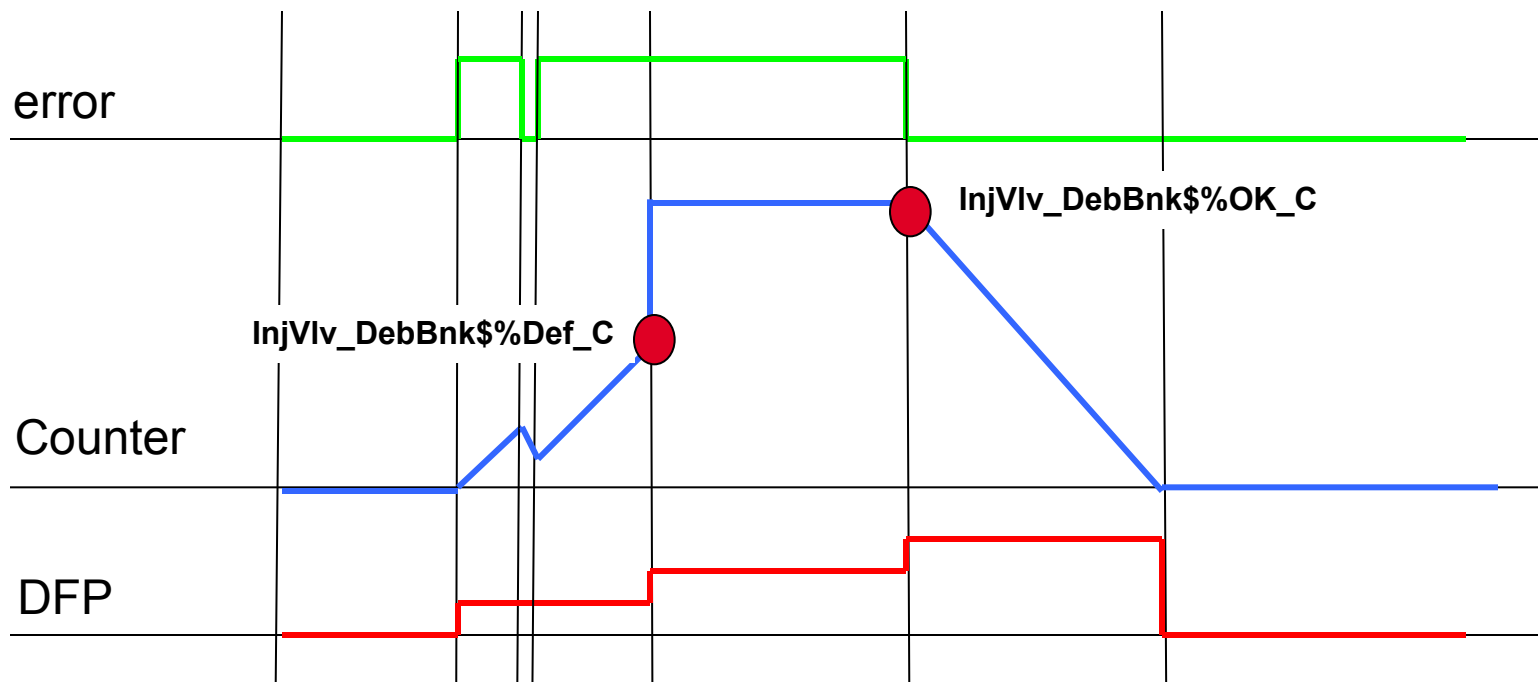

Error Debouncing

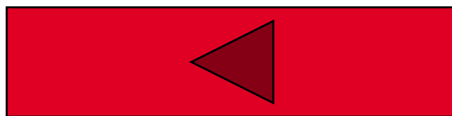
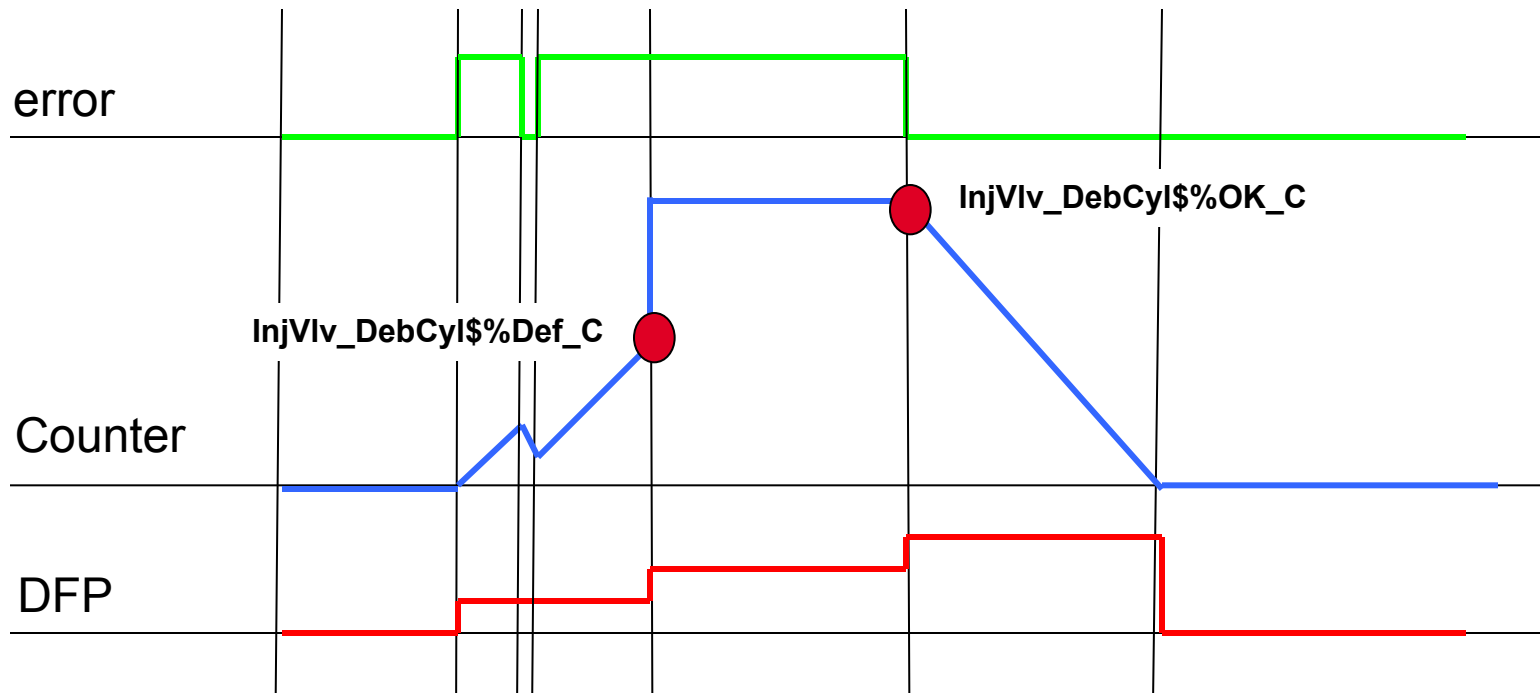

Overview of Diagnosis

Structure of the pattern matrix

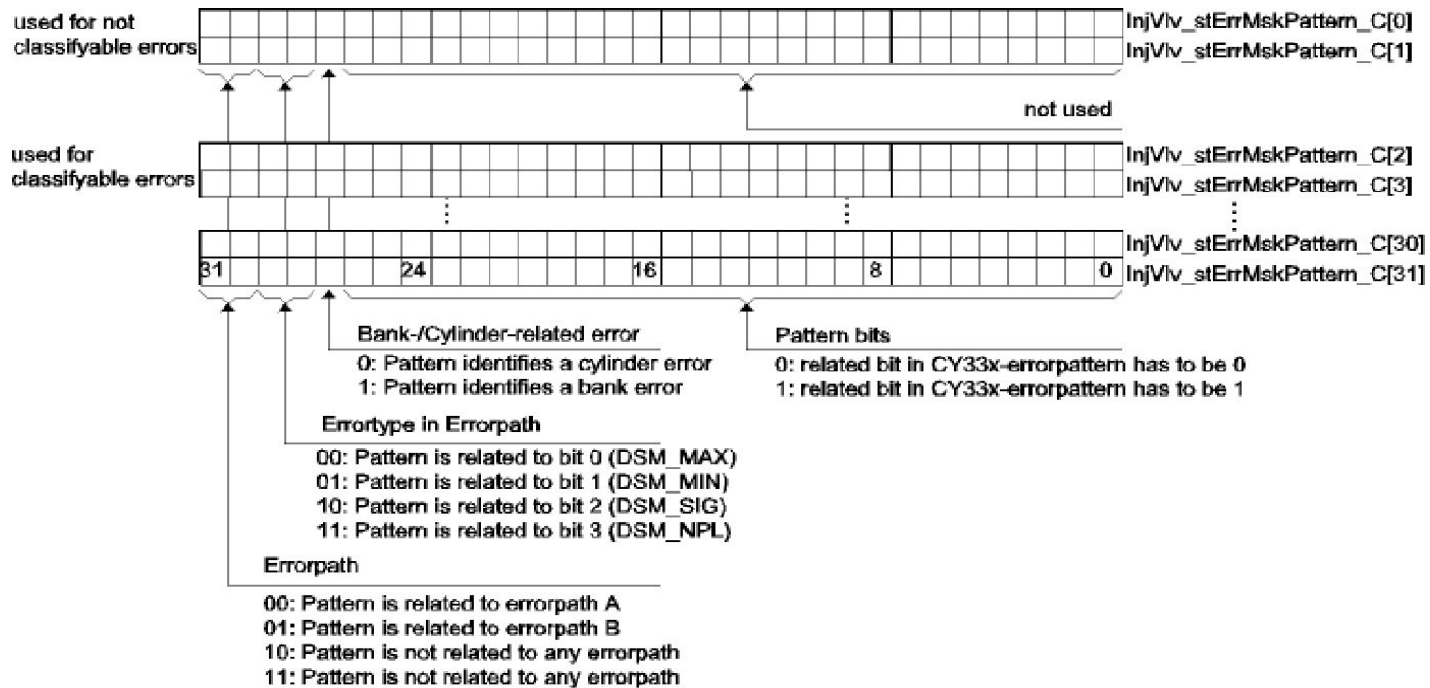

Structure of the Select Matrix

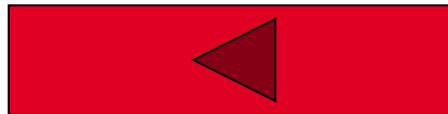
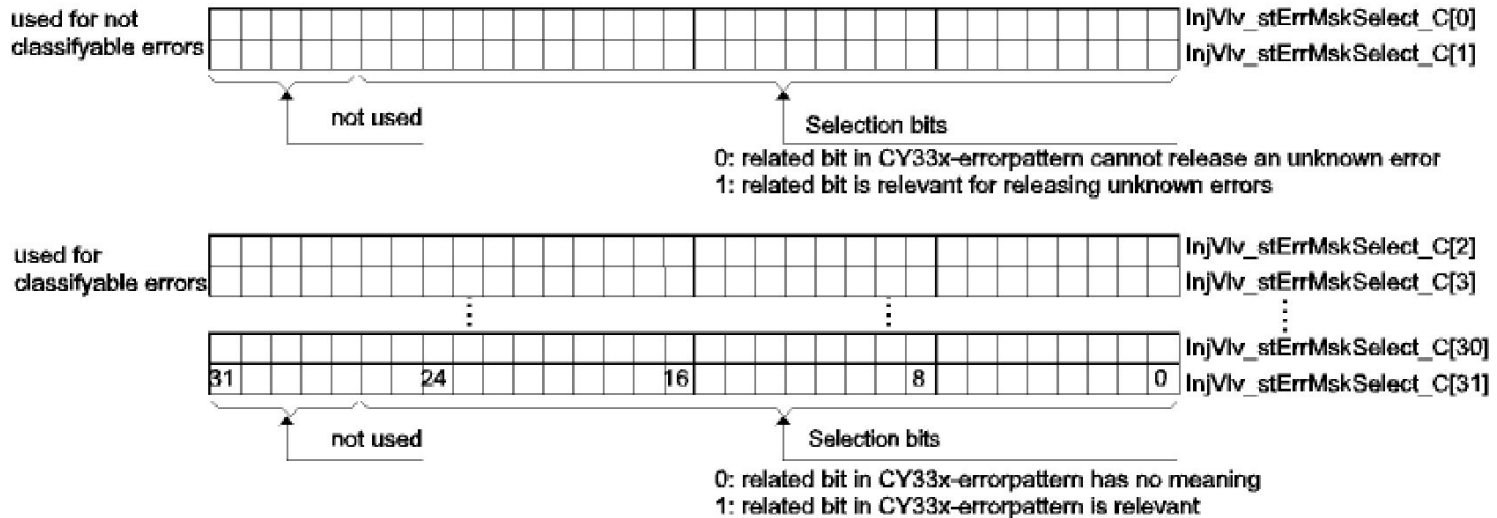

Structure of error pattern

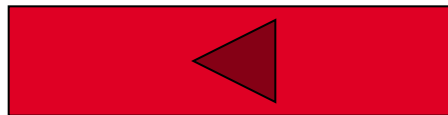
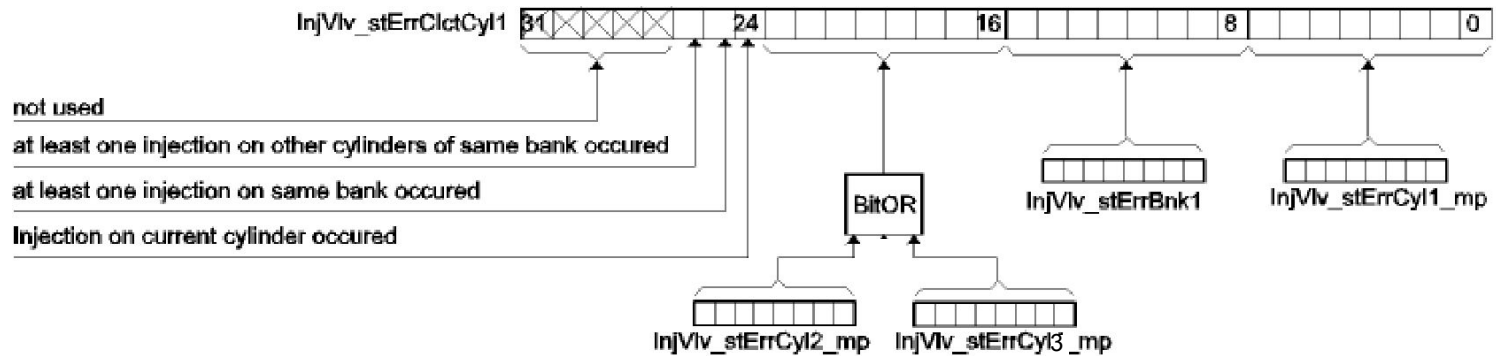

Pattern recognition sequence

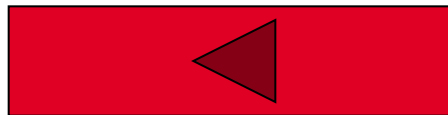
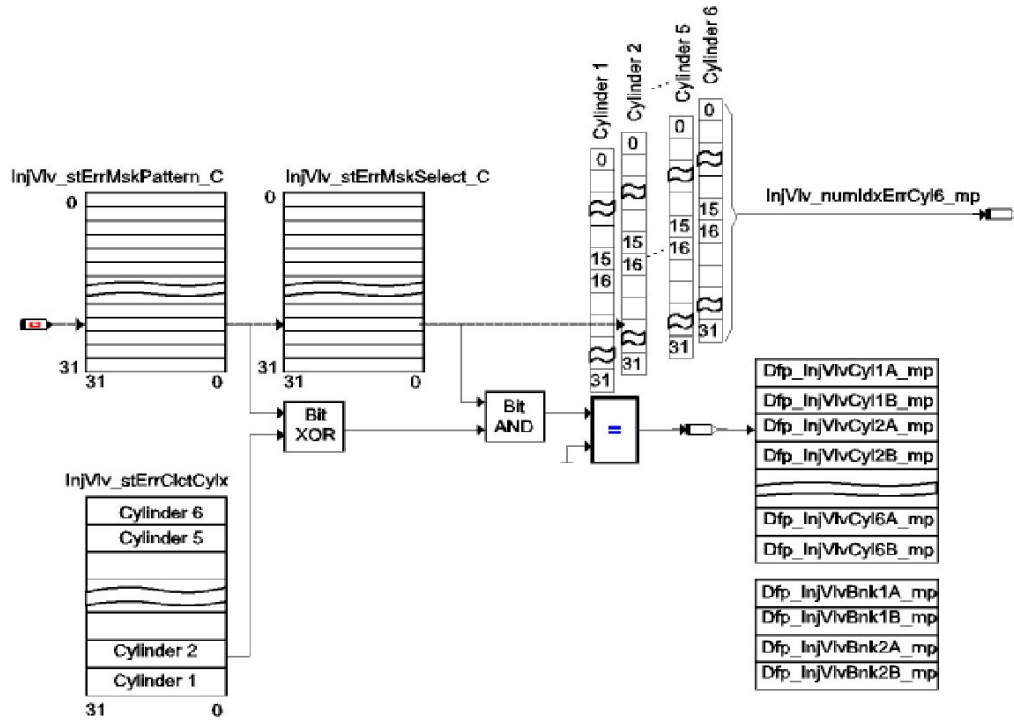

Cylinder specific error

BIT	CY332 ERROR
0	Maximal current in HS-Switch
1	Maximal current in LS-Switch
2	Differential current (HS-LS)
3	No load detected (open circuit)
4	Fast decay check failure
5	Recharge error
6	Current level error
7	Injection Finished

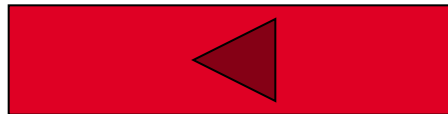

Bank specific error

BIT	CY332 ERROR
0	Booster voltage Over-range error
1	Booster voltage Under-range Error
2	Booster current-Low Error
3	Booster current-High Error
4	Booster Time-out Error
5	-
6	LS current Error
7	ON signal time out

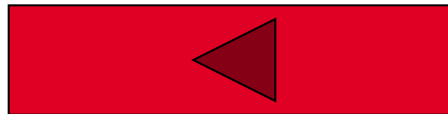

Shut Off debouncing

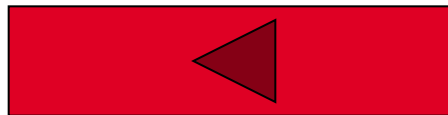
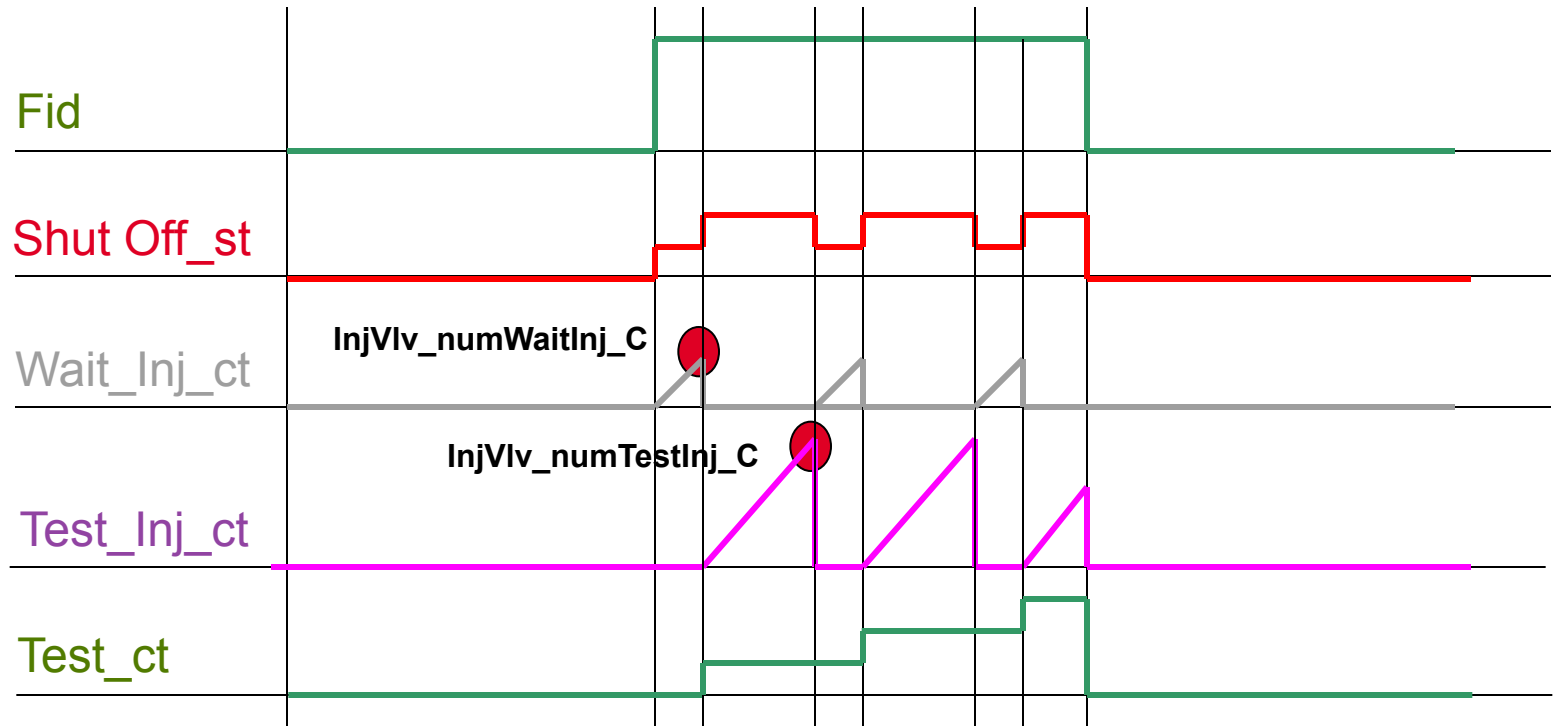

Shut Off

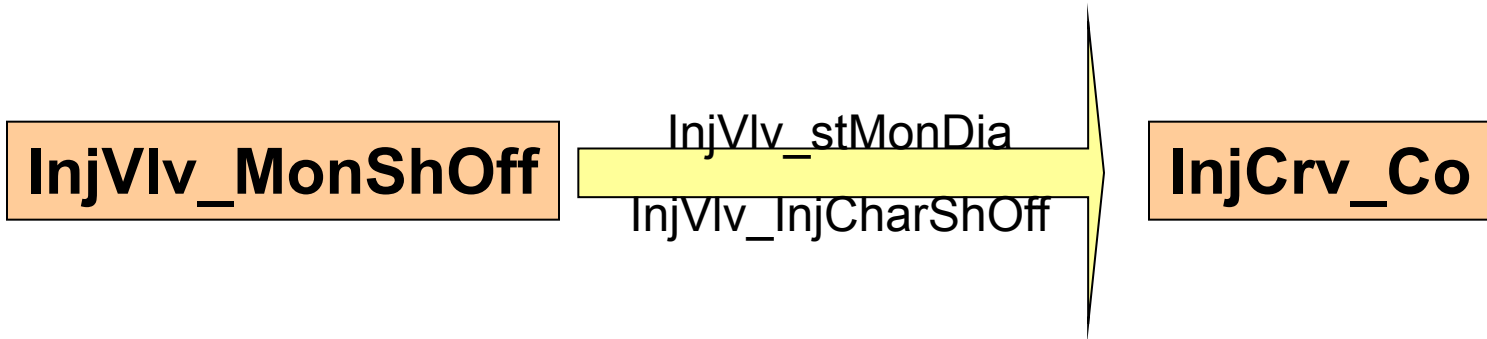

InjVlv_stMonDia								
Bit	7	6	5	4	3	2	1	0
	-	-	-	-	-	-	-	Dia ShutOff

InjVlv_InjCharShOff								
Bit	7	6	5	4	3	2	1	0
	-	PiI3	PiI2	PiI1	-	MI1	PoI2	PoI1

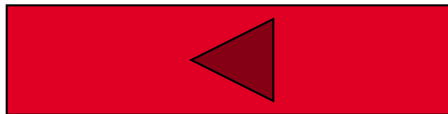

Open Circuit

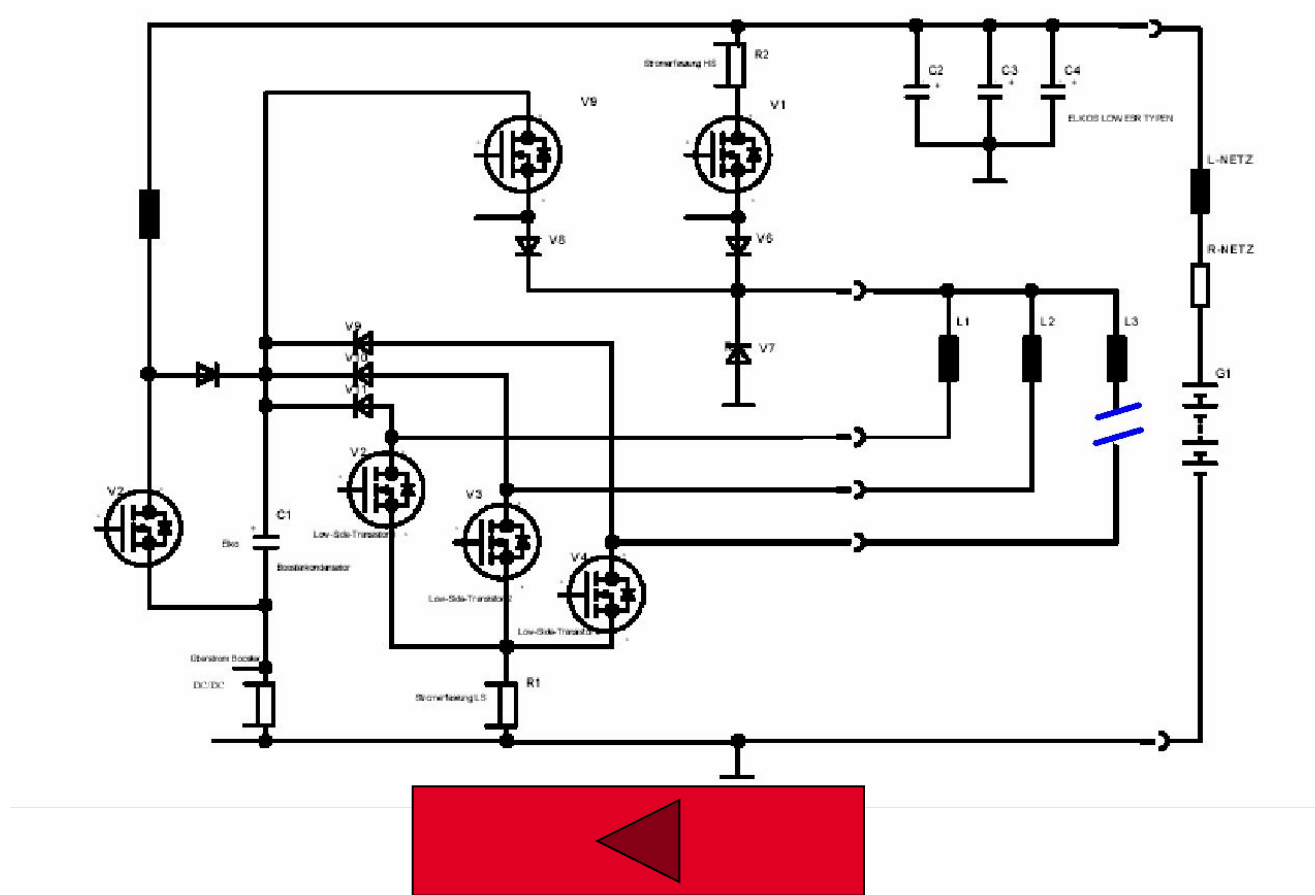

Short Circuit High Side to Battery

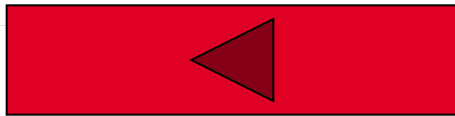
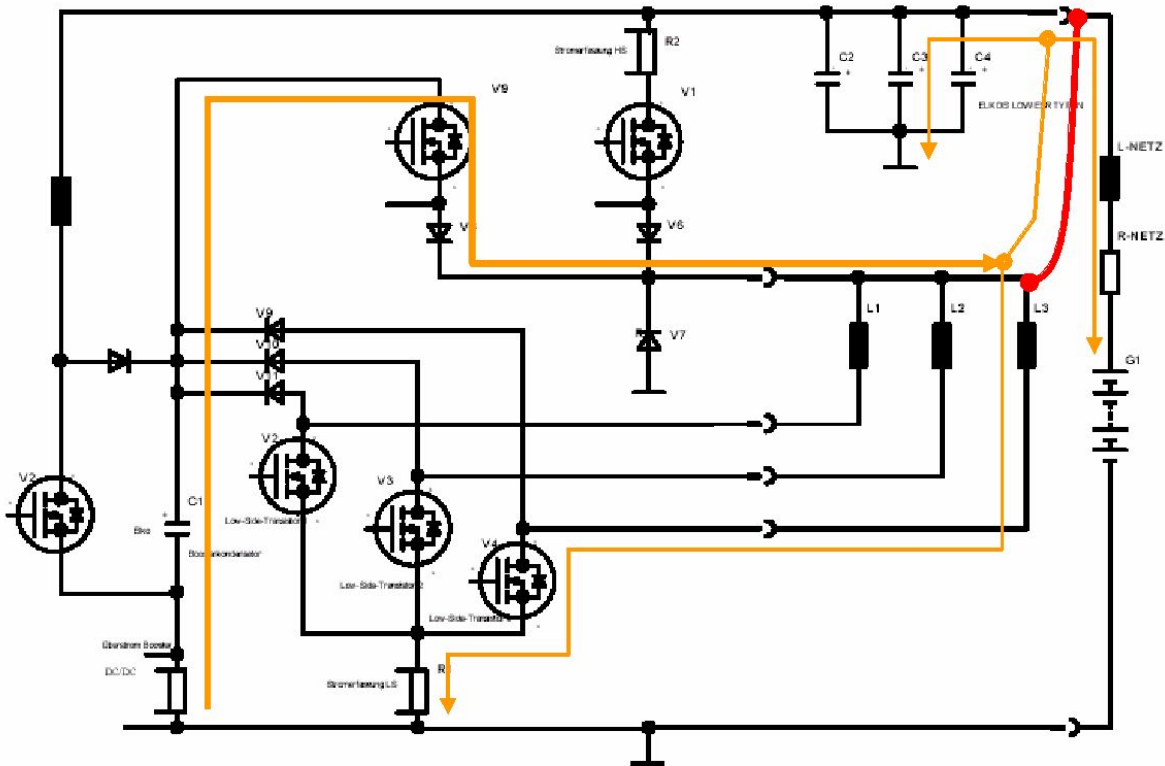

Short Circuit Low Side to Battery

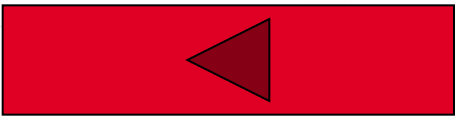
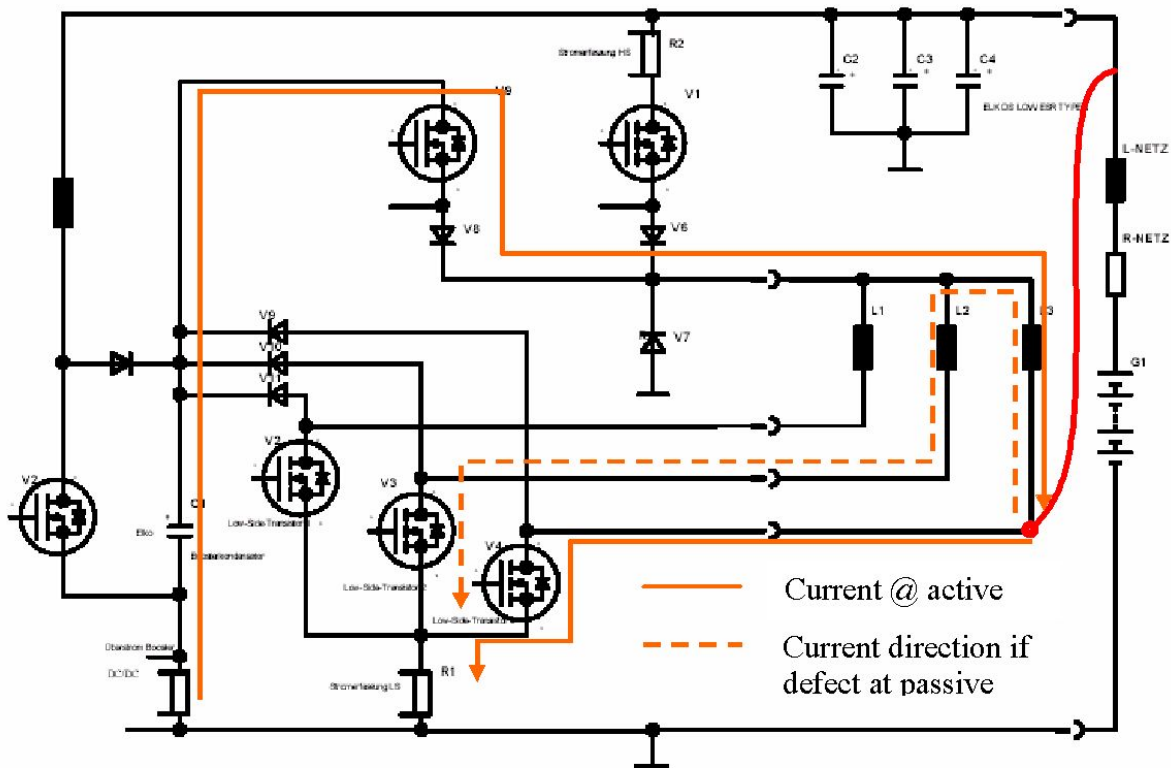

Overview of Diagnosis

Short Circuit Low Side to Ground

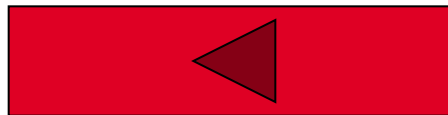
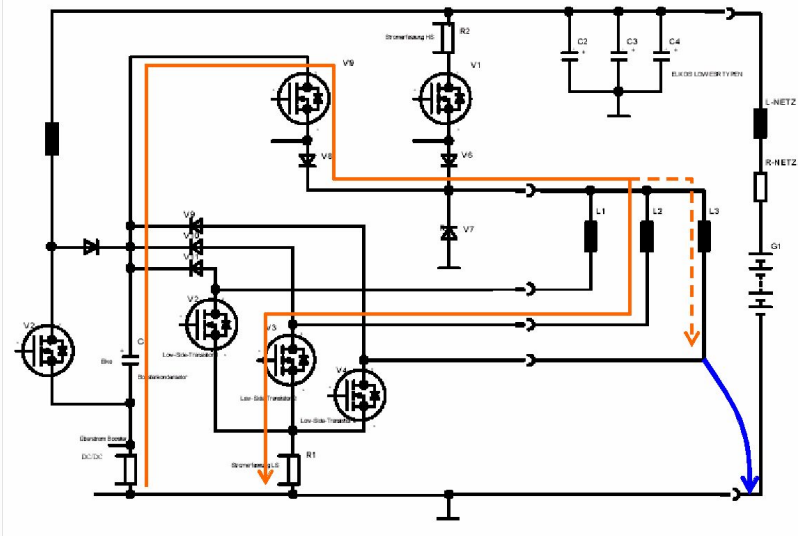
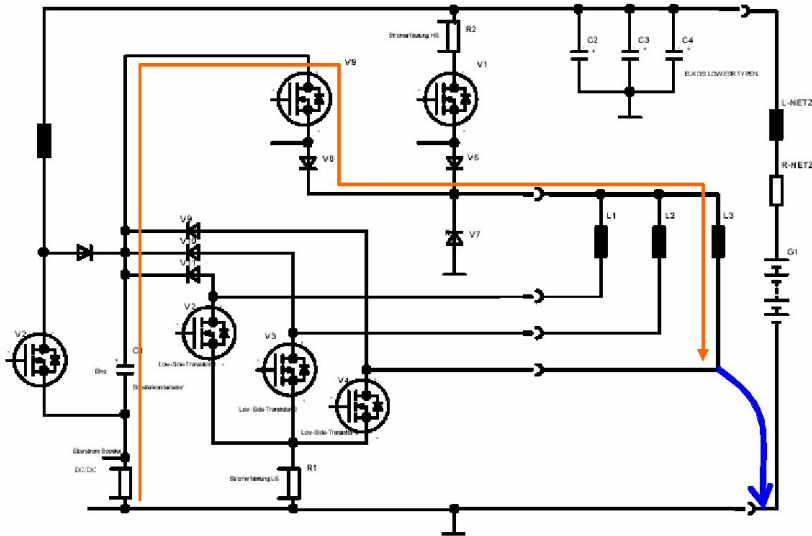

Short Circuit High Side to Low Side

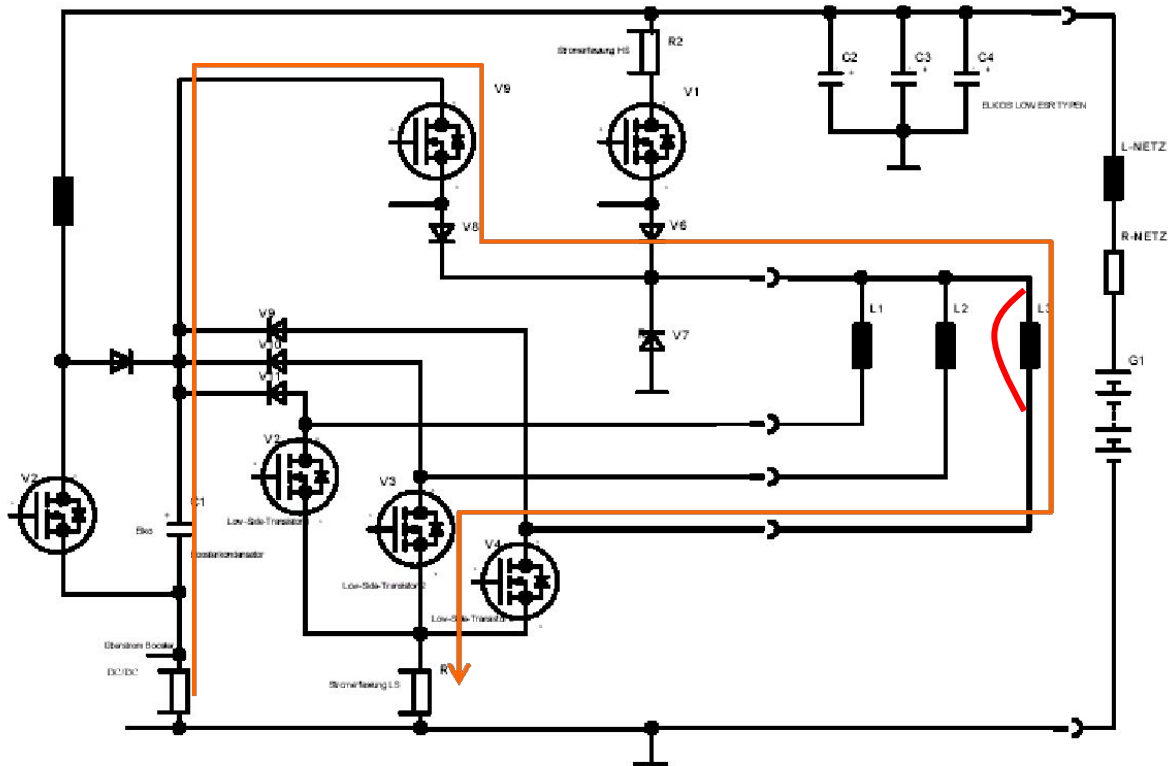

Error messages transferred via SPI (16)

InjVlv_stErrBnk\$ _mp.Bit4 - Booster Time-out Error

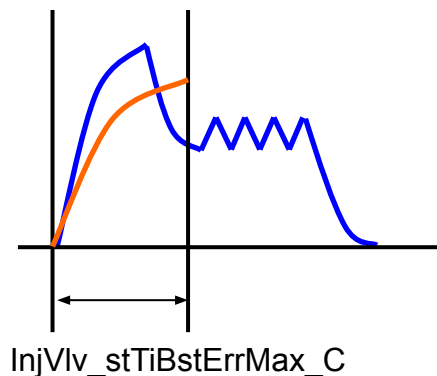
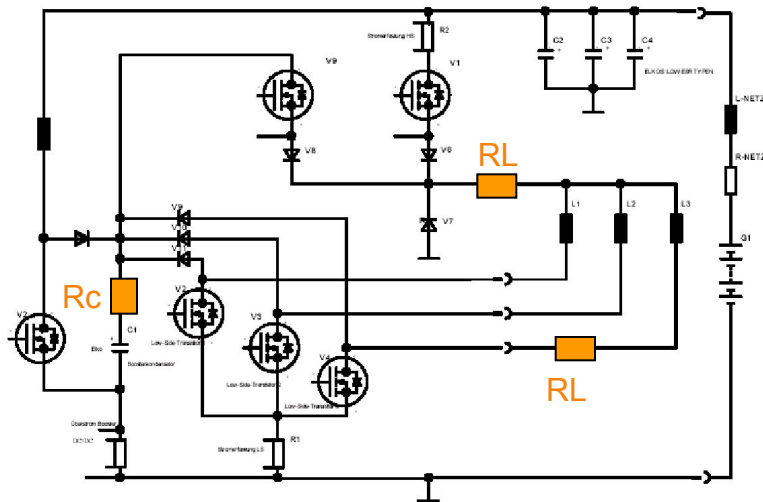

After the time $InjVlv_stTiBstErrMax_C$ the current $InjVlv_iLvLo1_C$ is not reached.

- Old SG → ↑ Rc
- ↓ Temp → ↑ Rc
- ↑ Temp → ↑ RL

