

- 1/RED and 13/BLK will remain as before.
- All other wires will have a specific wire color based on the one's digit of the wire number as follows:

x1=PNK (except 1/RED)	x6=BLU
x2=BRN	x7=PUR
x3=DRA (except 13/BLK)	x8=GRY
x4=YEL	x9=WHT
x5=BRN	x10=TAN

System at Rest

T7 Electrical Schematic

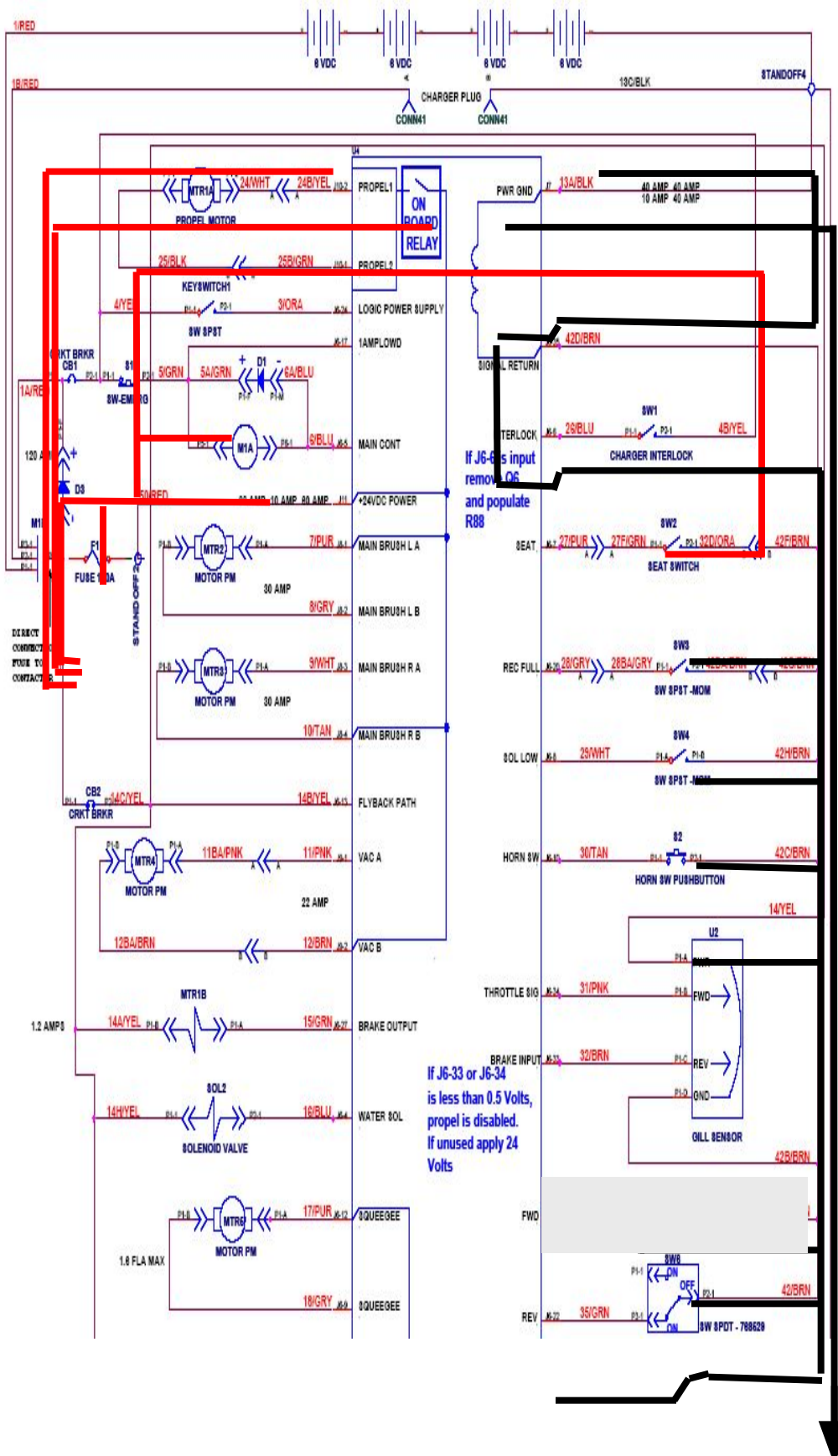

T7 Electrical Schematic

While Charging

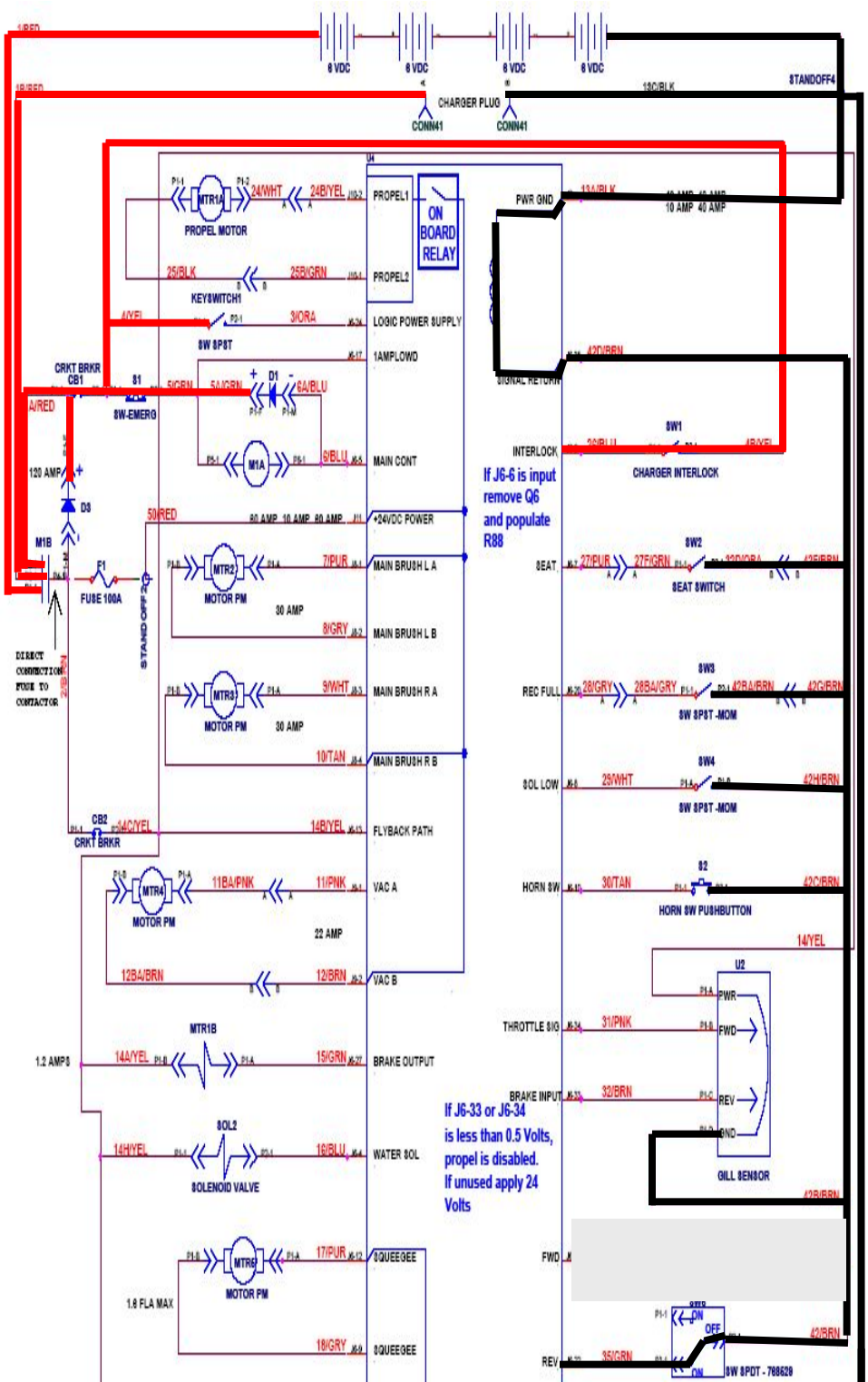

T7 Electrical Schematic

Key On – M1 Energized – Seat Switch Closed

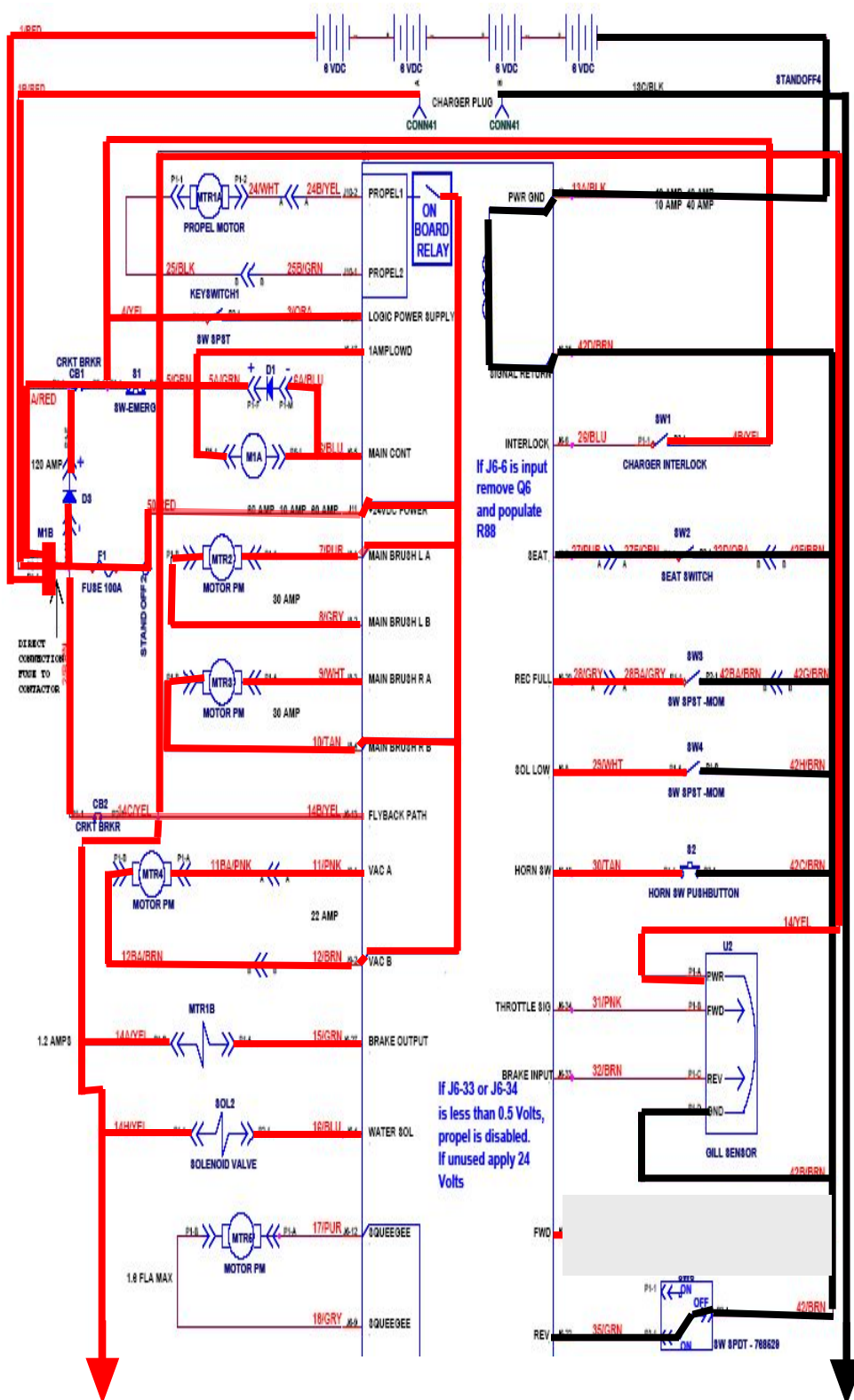

T7 Electrical Schematic

Propel Fwd. - Scrub Brushes
On - Water On - Vacuum On -
Brake Off

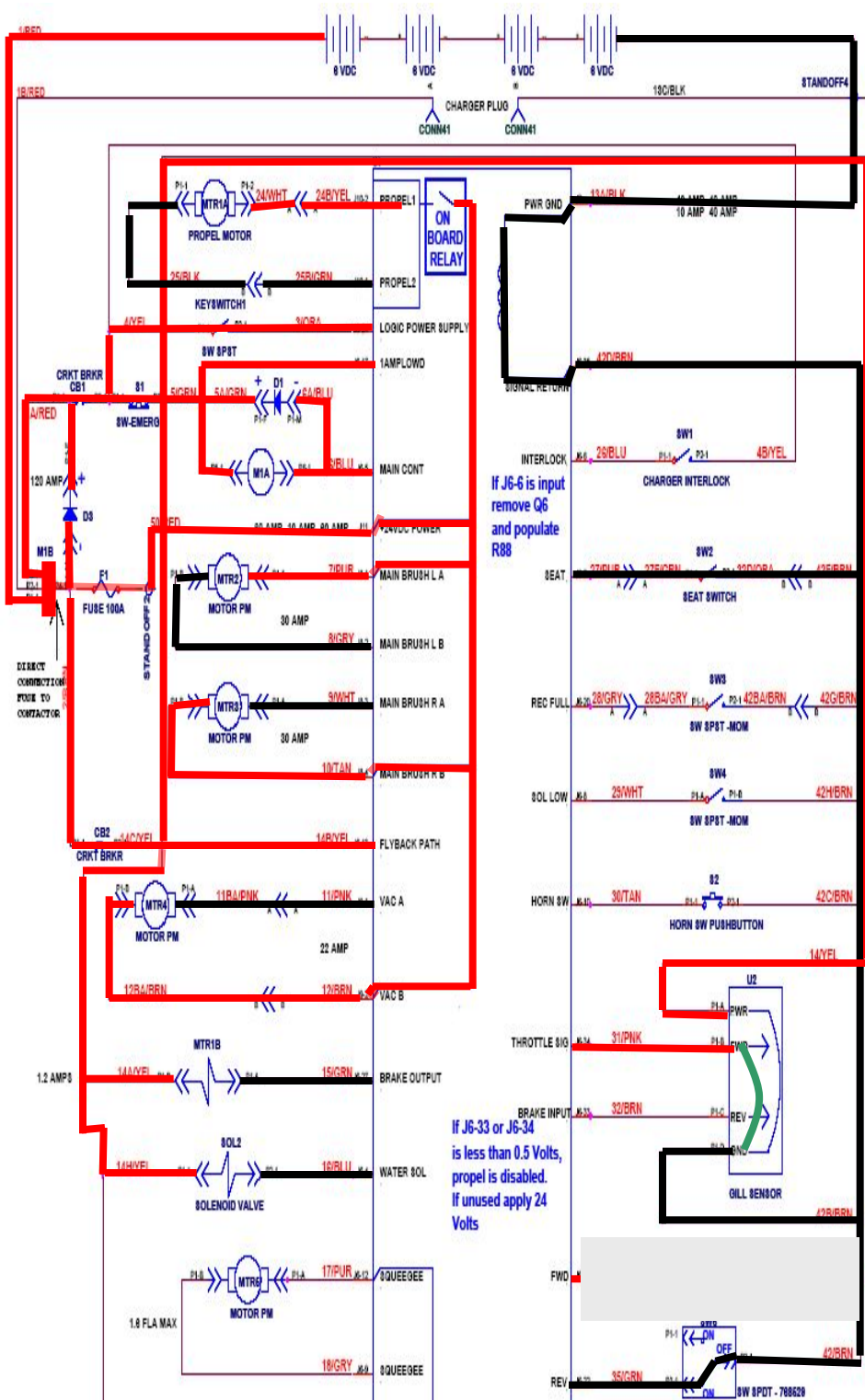

T7 Electrical Schematic

Propel Rev. - Scrub Brushes On - Water On - Brake Off

