

FIG 101

CYLINDER BLOCK GROUP

T543/T603

P1

Year / Month

2007 / 02

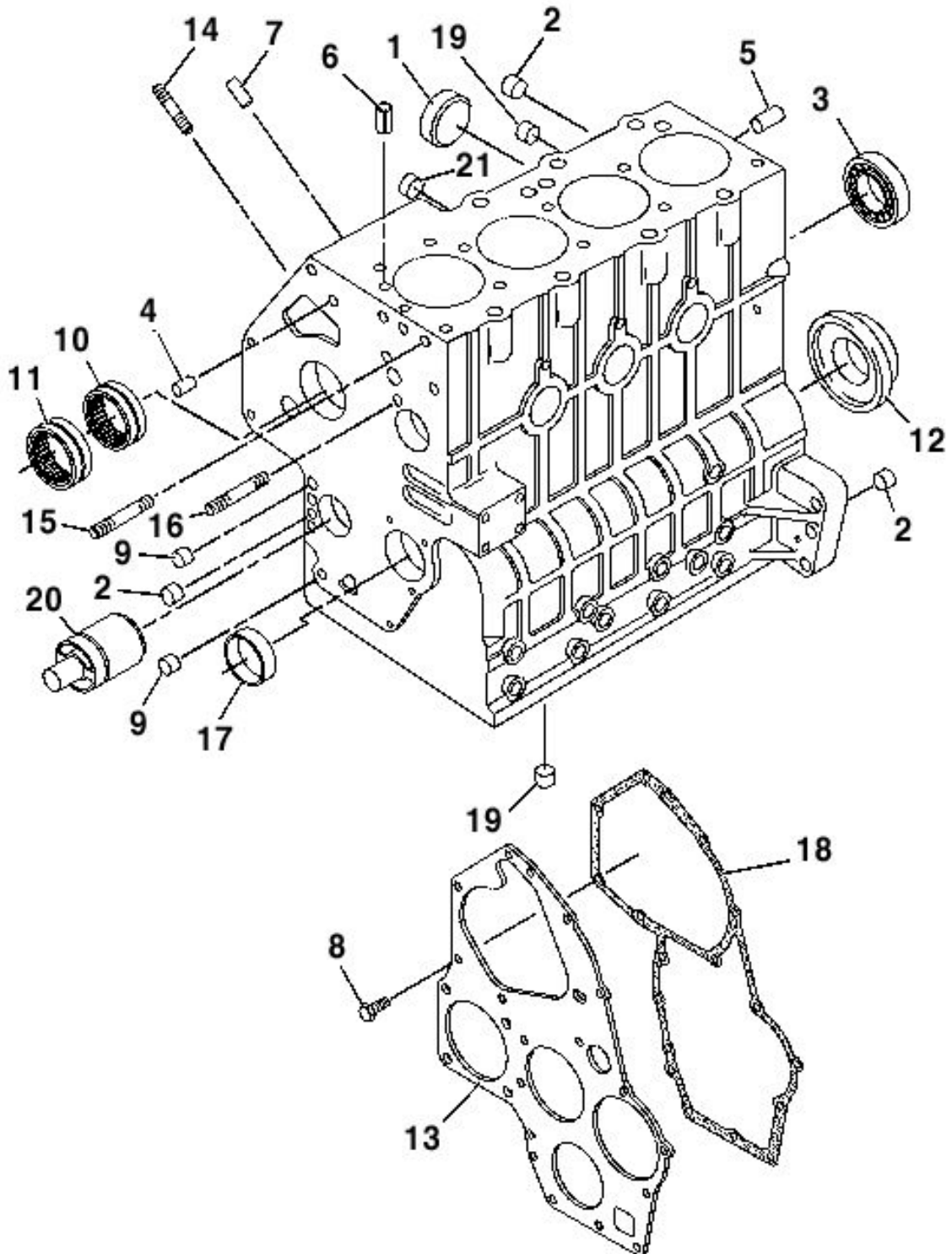
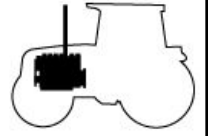

NOTE

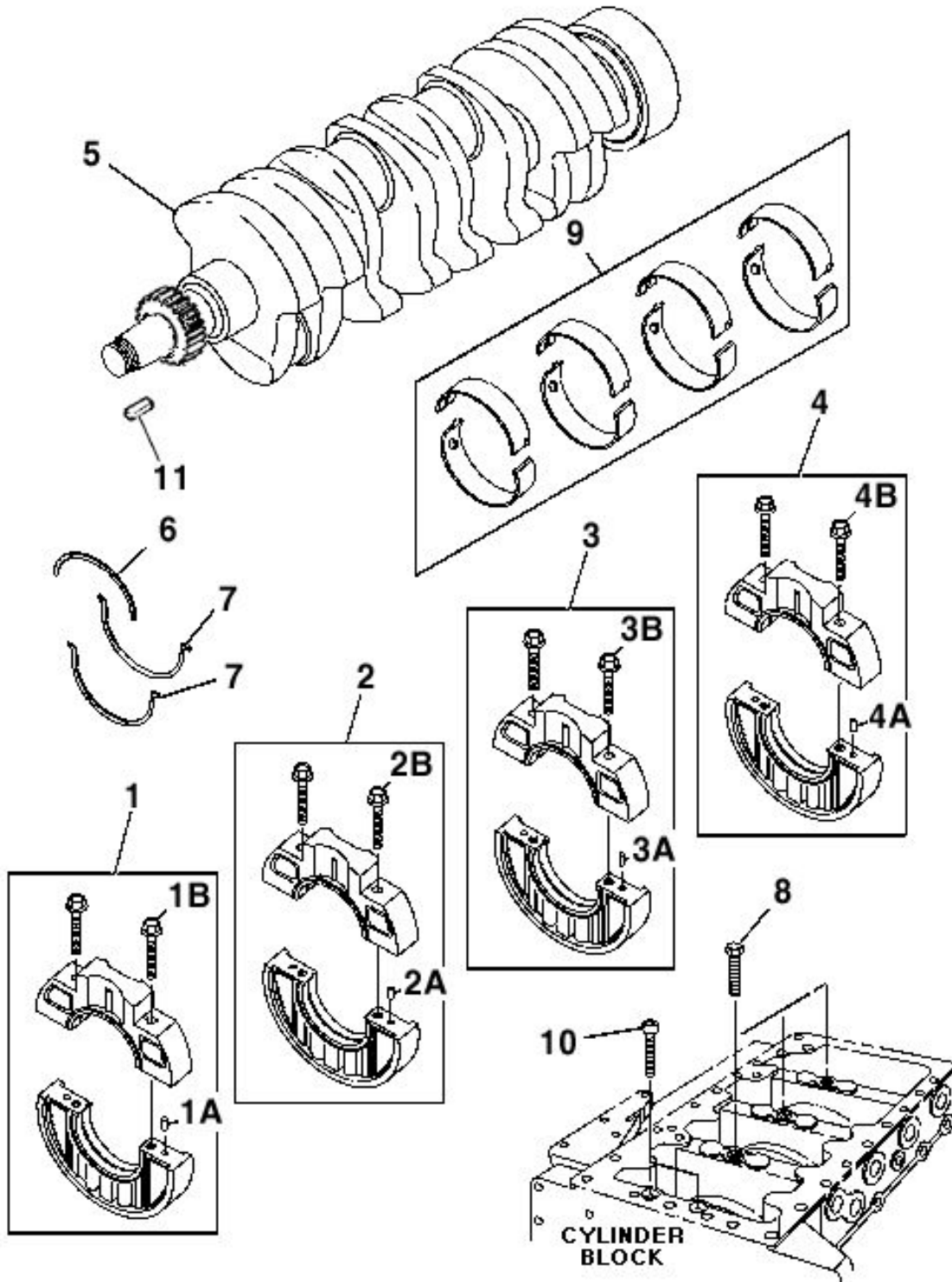
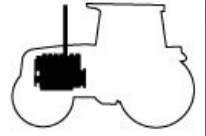

FIG 103

T543/T603

PAN GROUP-OIL

P1

Year / Month

2007 / 02

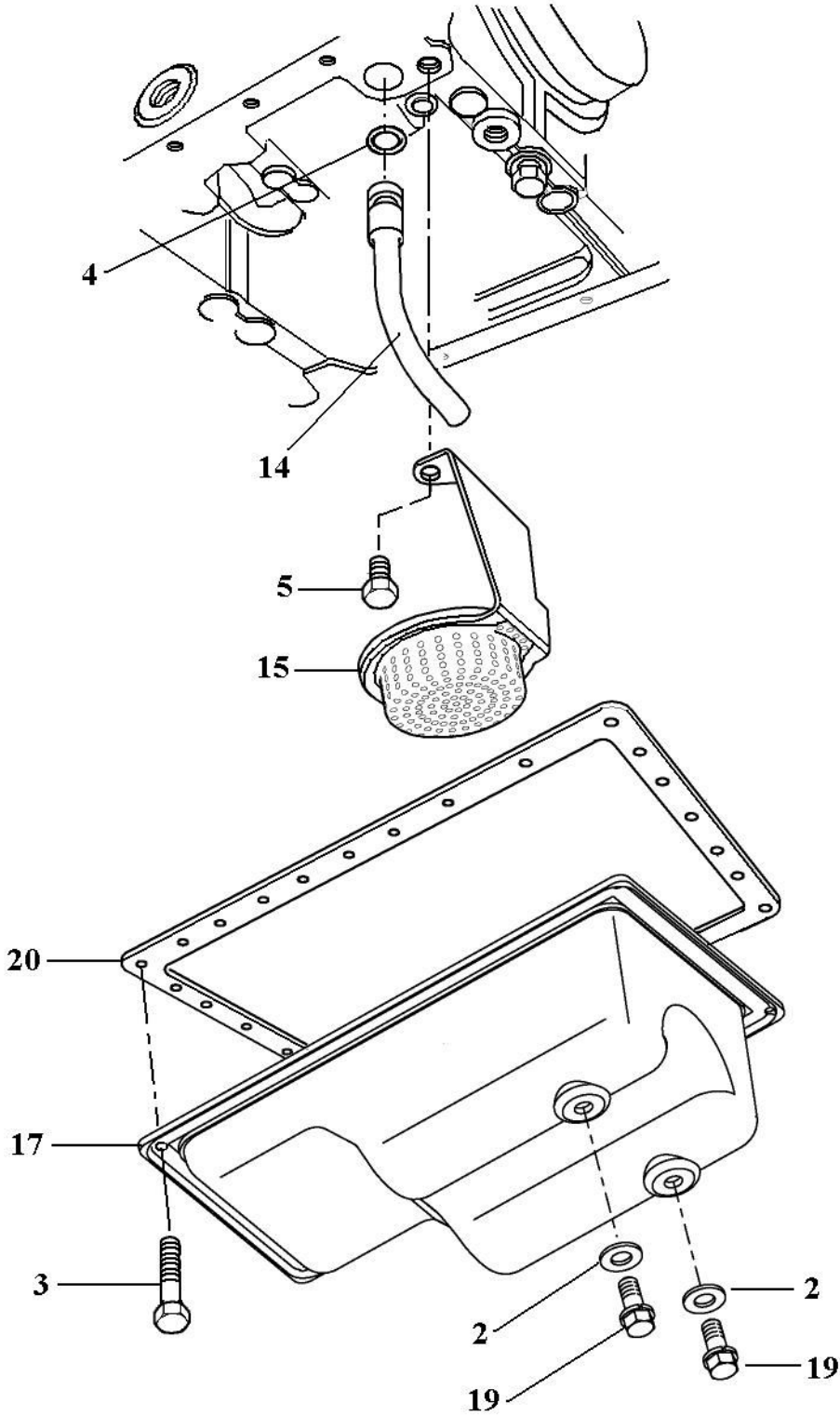
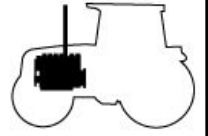

NOTE

FIG 103

PAN GROUP-OIL

T543/T603

P2

Year / Month

2007 / 02

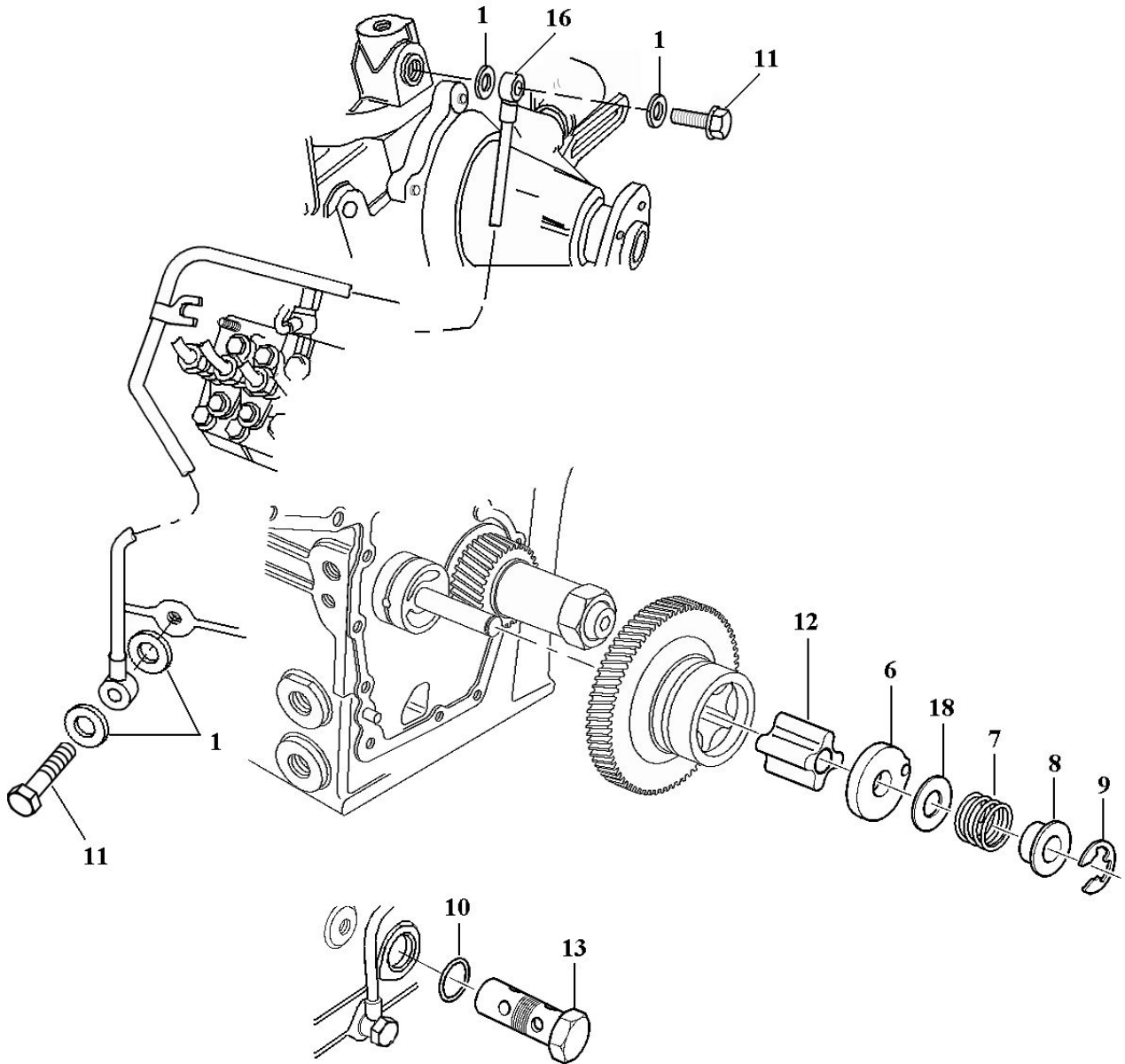

NOTE

FIG 104

T543/T603

PISTON & ROD GROUP

P1

Year / Month

2007 / 02

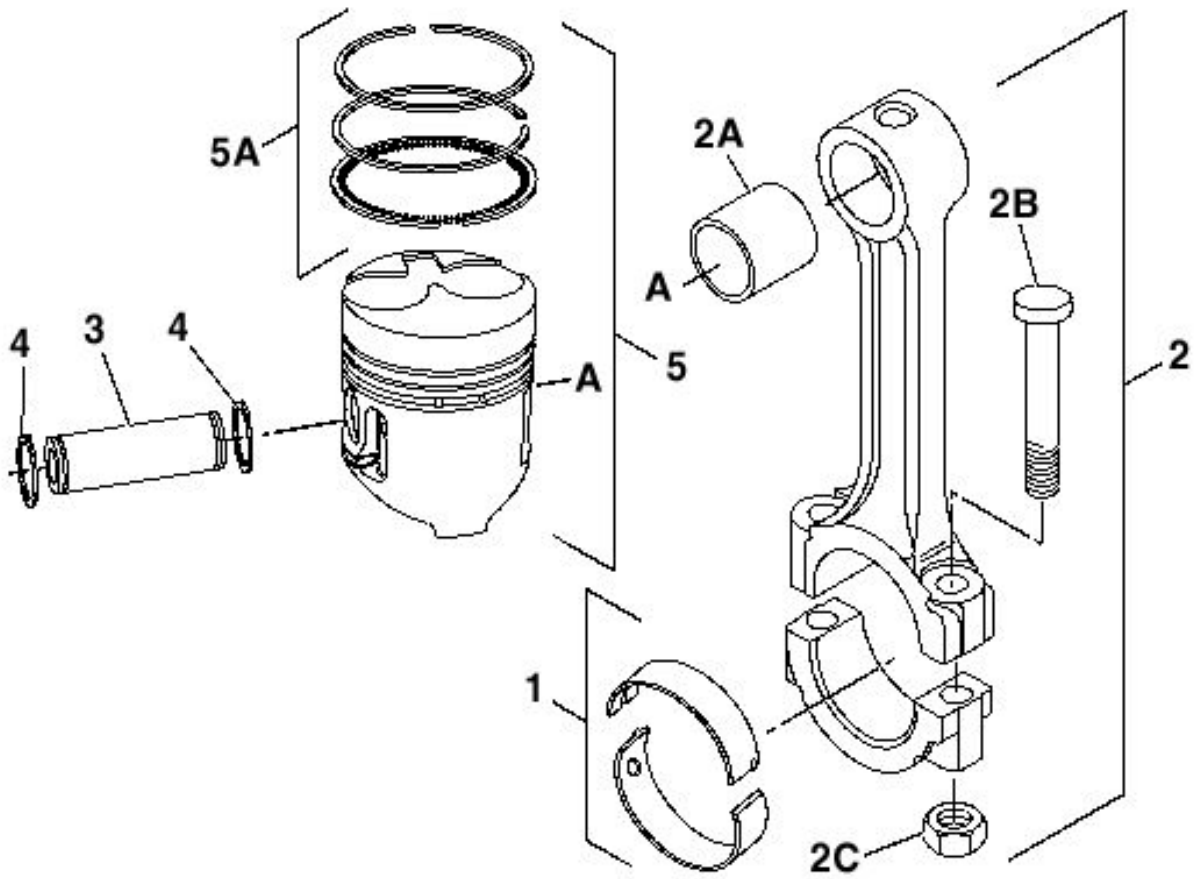
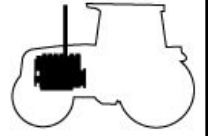

NOTE

FIG 105

CAMSHAFT GROUP

T543/T603

P1

Year / Month

2007 / 02

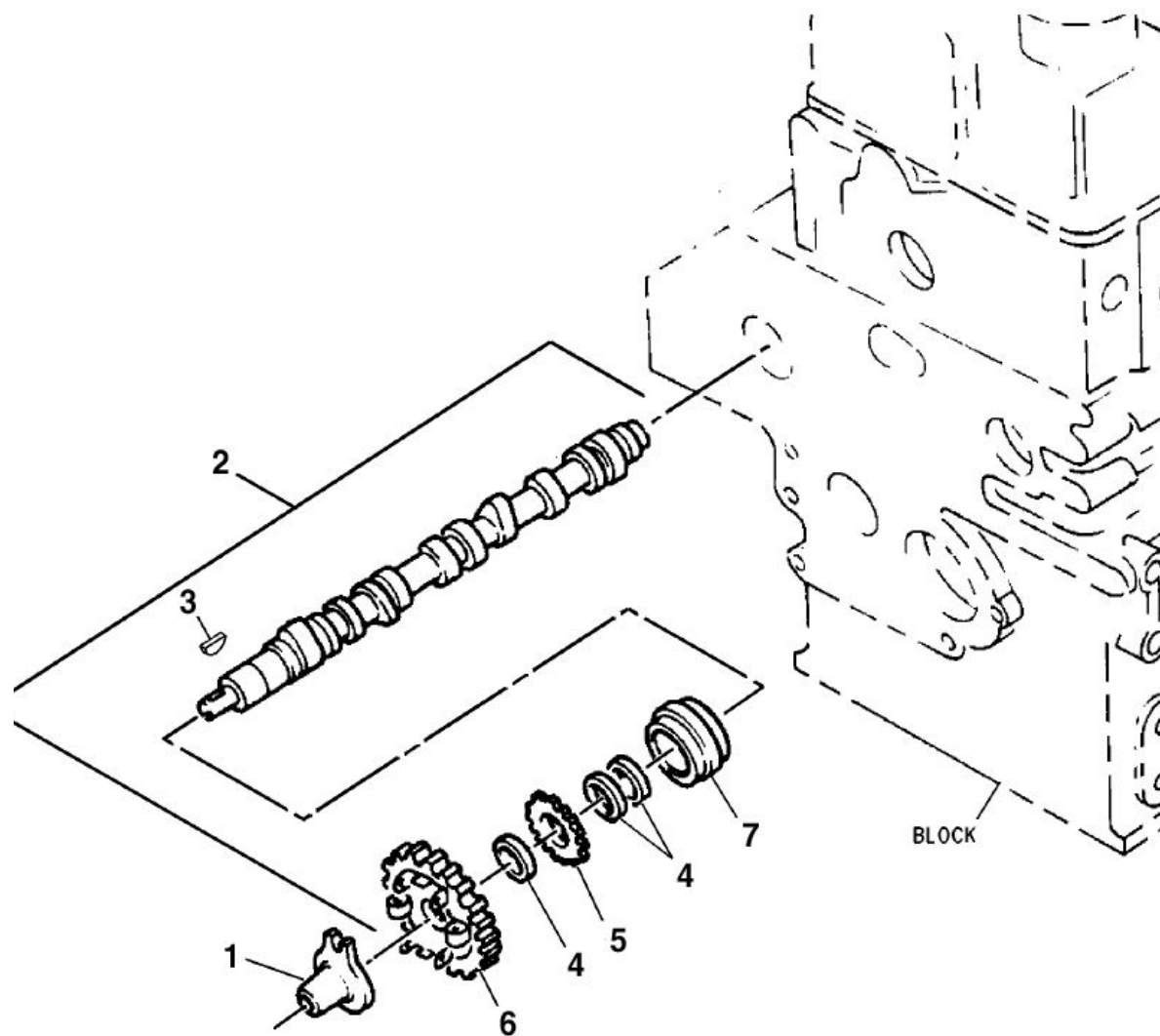

NOTE

FIG 106

HOUSING GROUP-FRONT

T543/T603

P1

Year / Month

2007 / 02

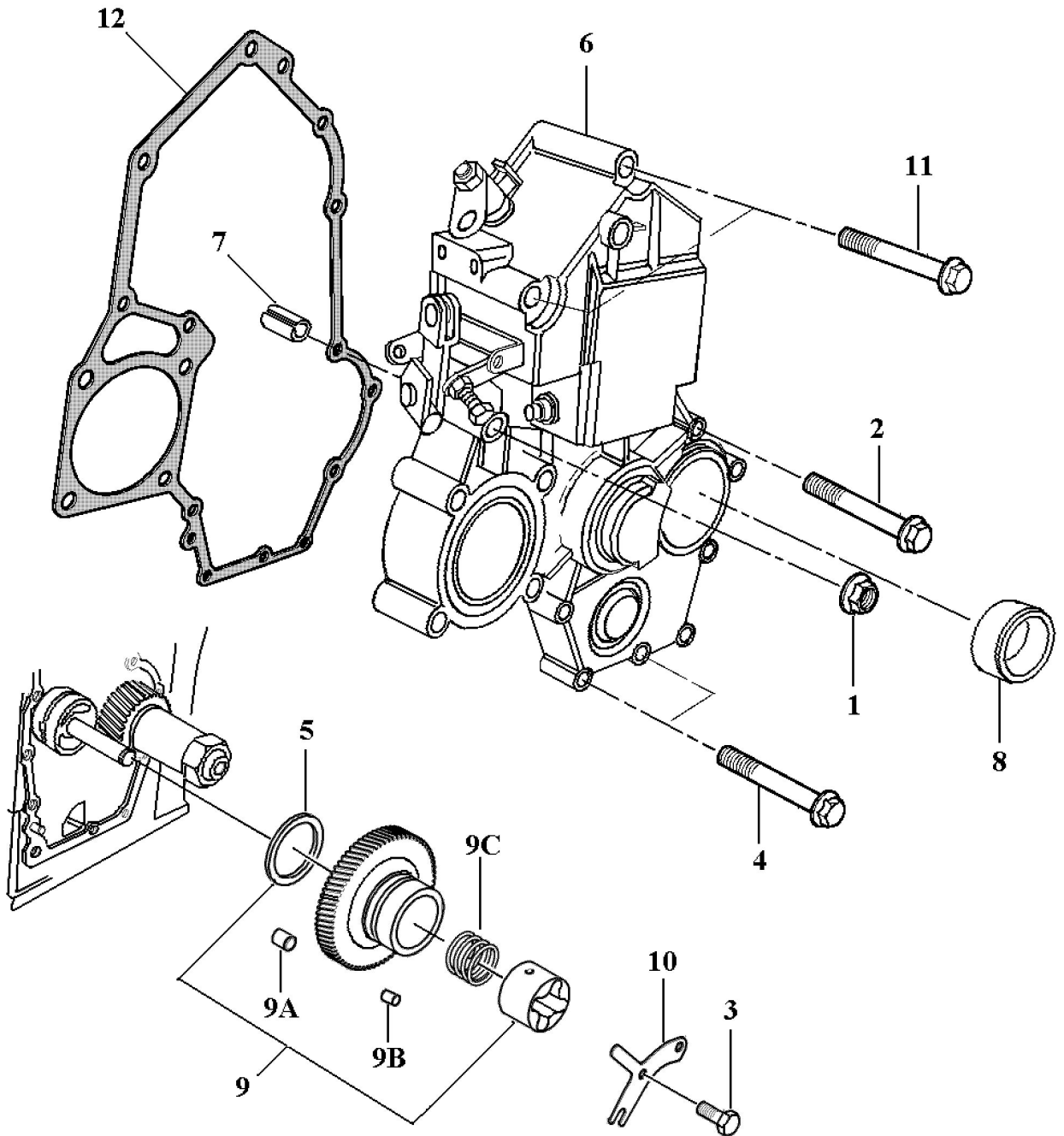
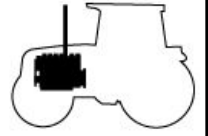

NOTE

FIG 107

GOVERNOR GROUP

T543/T603

P1

Year / Month

2007 / 02

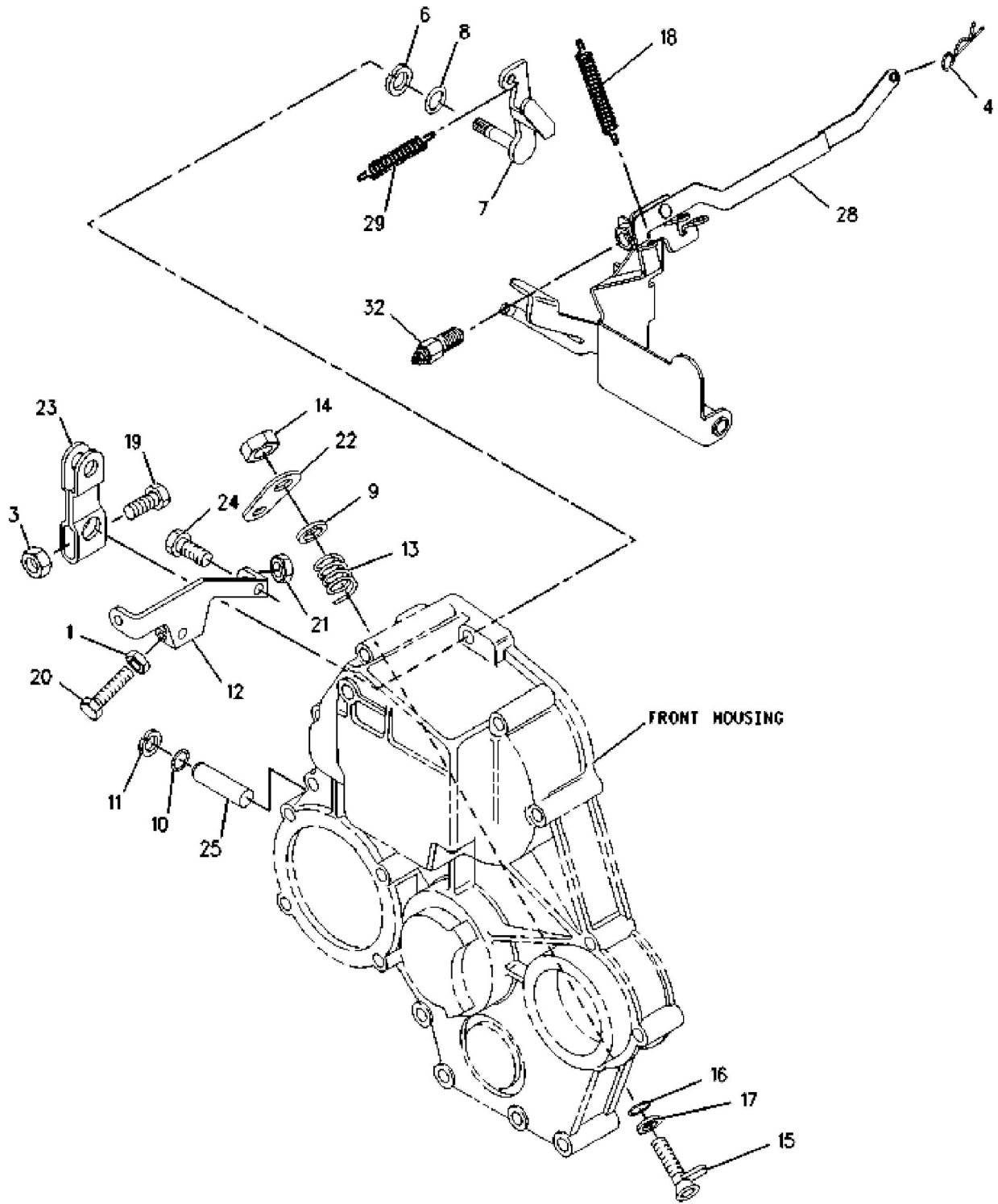
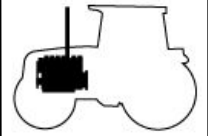

NOTE

FIG 107

GOVERNOR GROUP

T543/T603

P2

Year / Month

2007 / 02

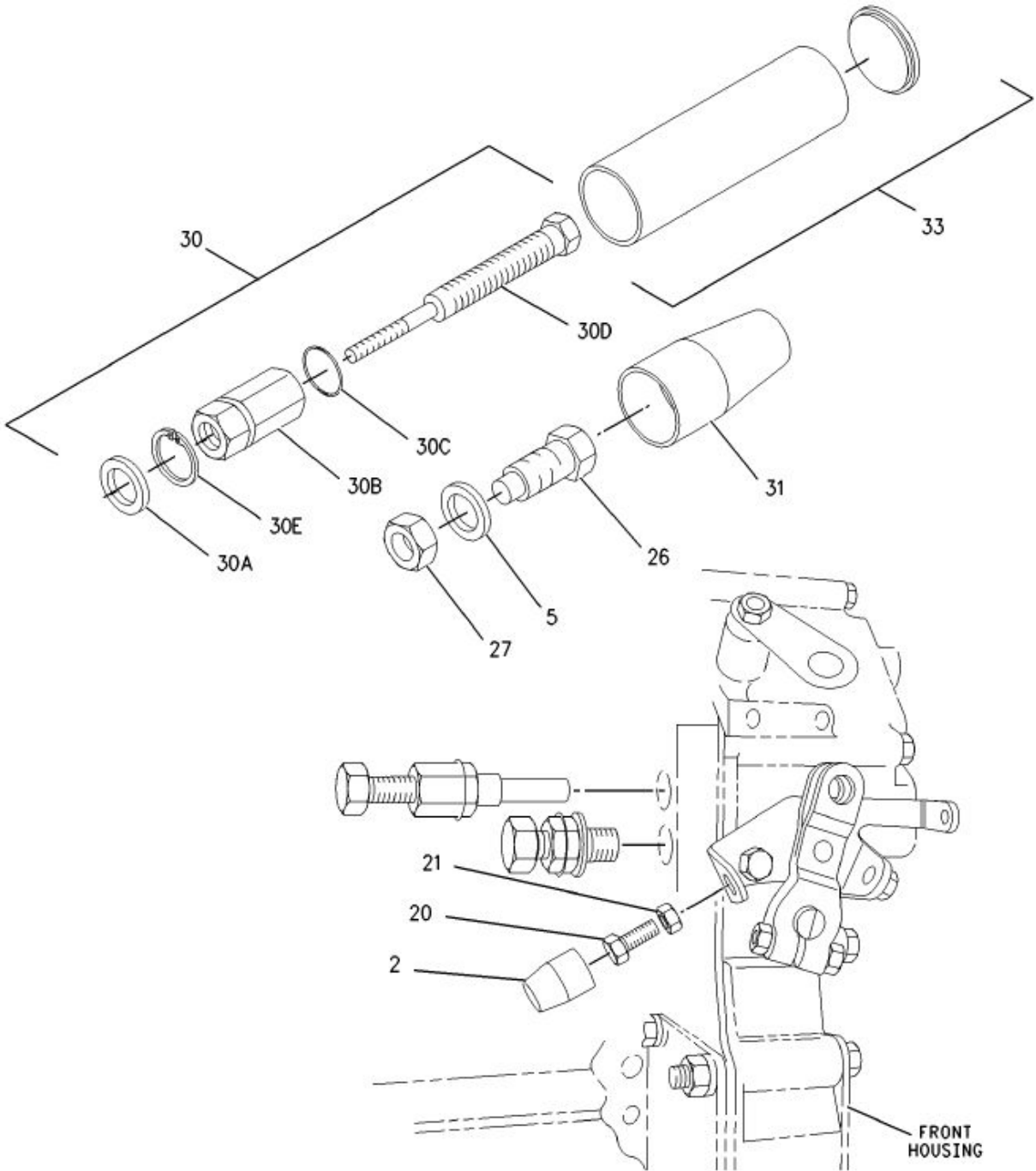
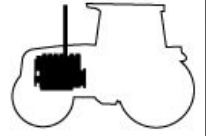

NOTE

FIG 108

T543/T603

BEARING & GEAR

P1

Year / Month

2007 / 02

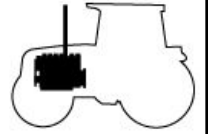

Engine

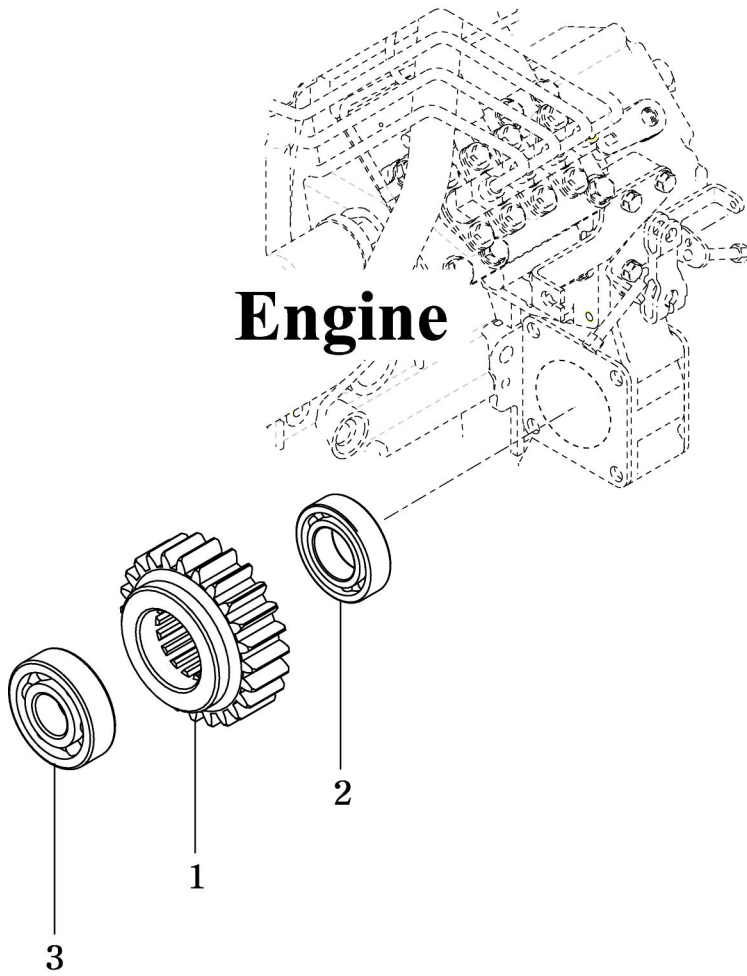

NOTE

FIG 109

PULLEY GROUP-AUXILIARY DRIVE

T543/T603

P1

Year / Month

2007 / 02

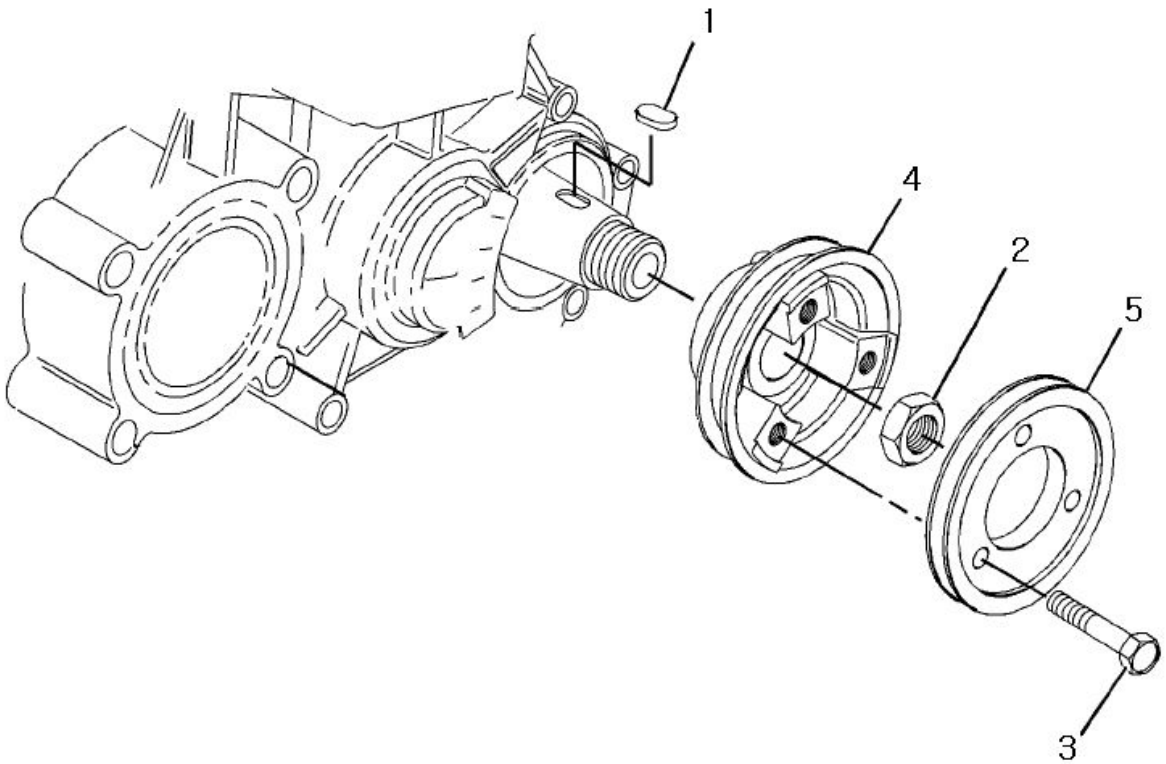
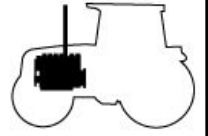

NOTE

FIG 110

T543/T603

CYLINDER HEAD GROUP (1)

P1

Year / Month

2007 / 02

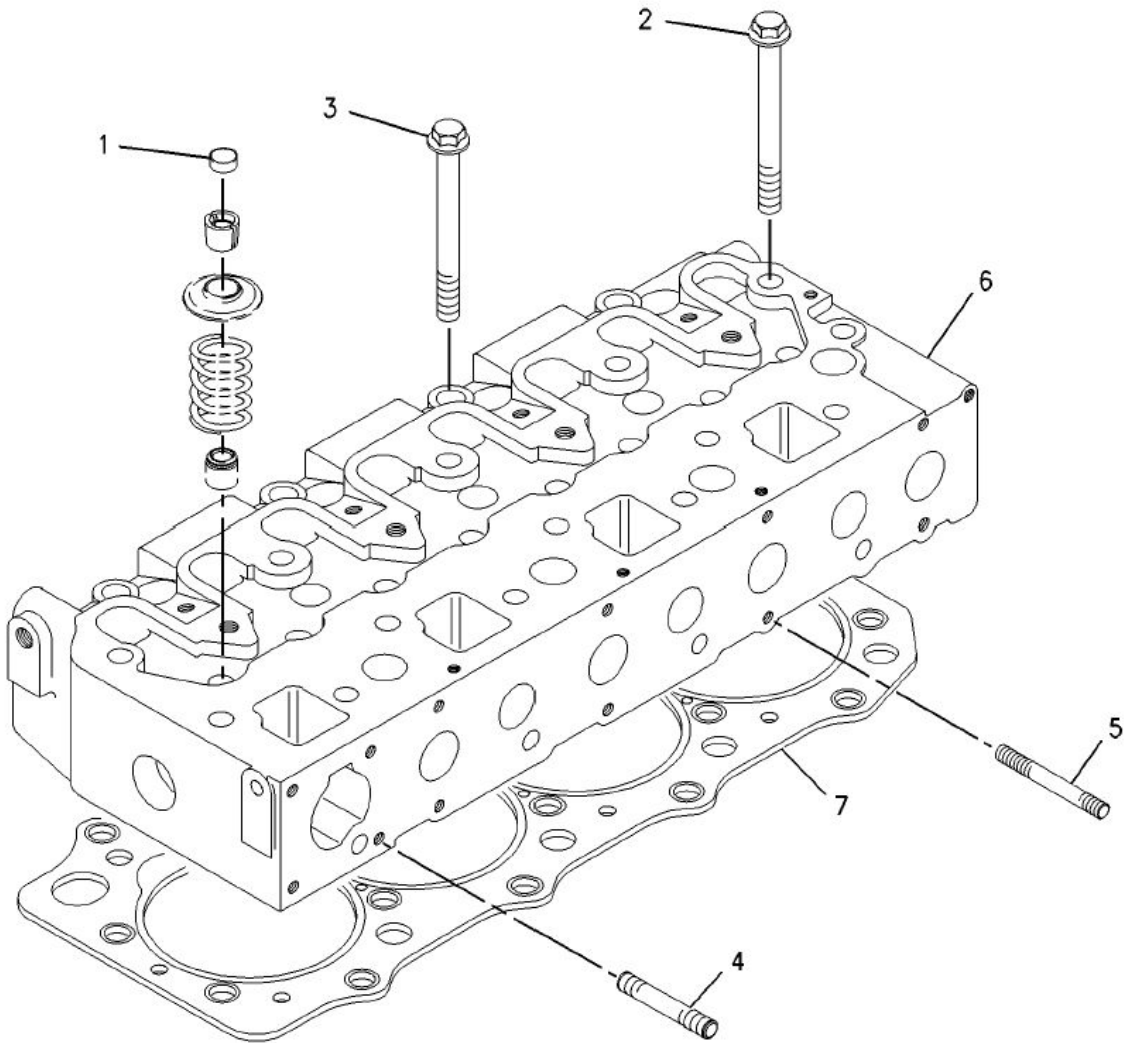

NOTE

FIG 111

CYLINDER HEAD GROUP (2)

T543/T603

P1

Year / Month

2007 / 02

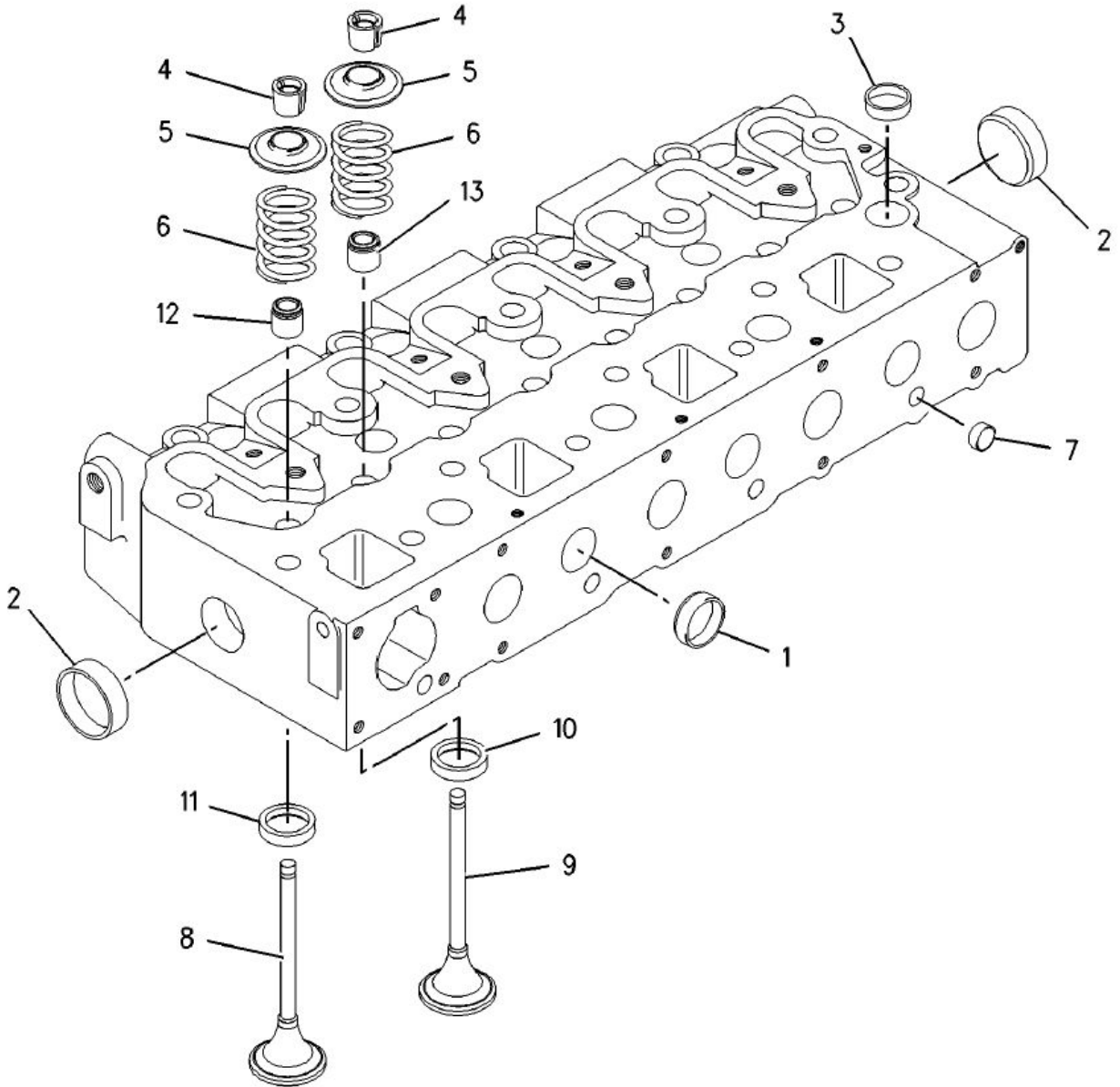
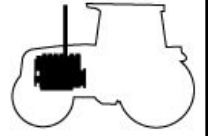

NOTE

FIG 112

VALVE MECHANISM GROUP

T543/T603

P1

Year / Month

2007 / 02

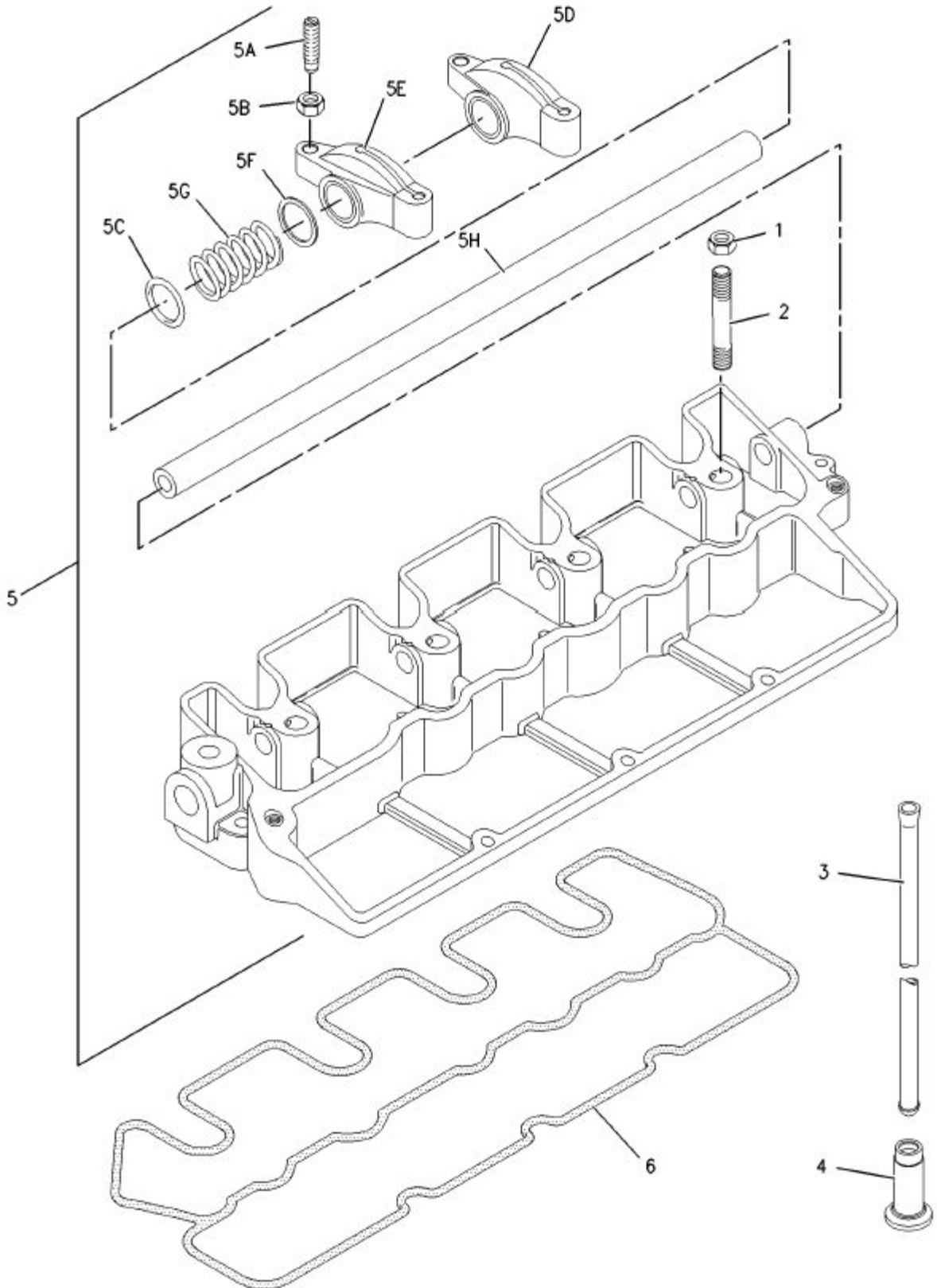
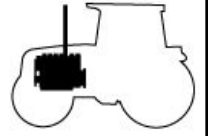

NOTE

FIG 113

COVER GROUP-VALVE MECHANISM

T543/T603

P1

Year / Month

2007 / 02

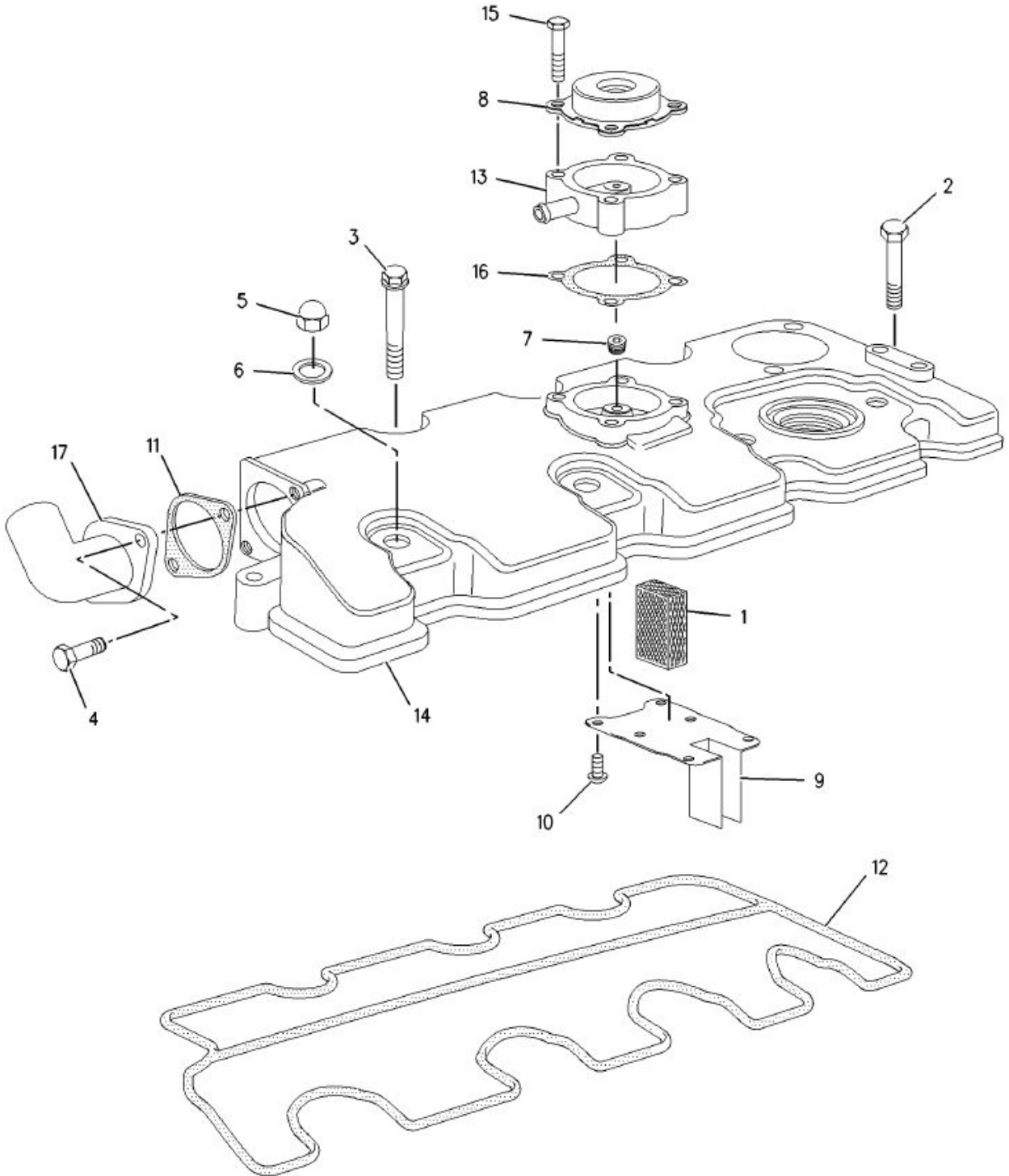
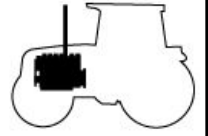

NOTE

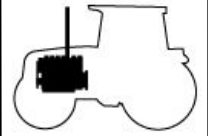

T543/T603

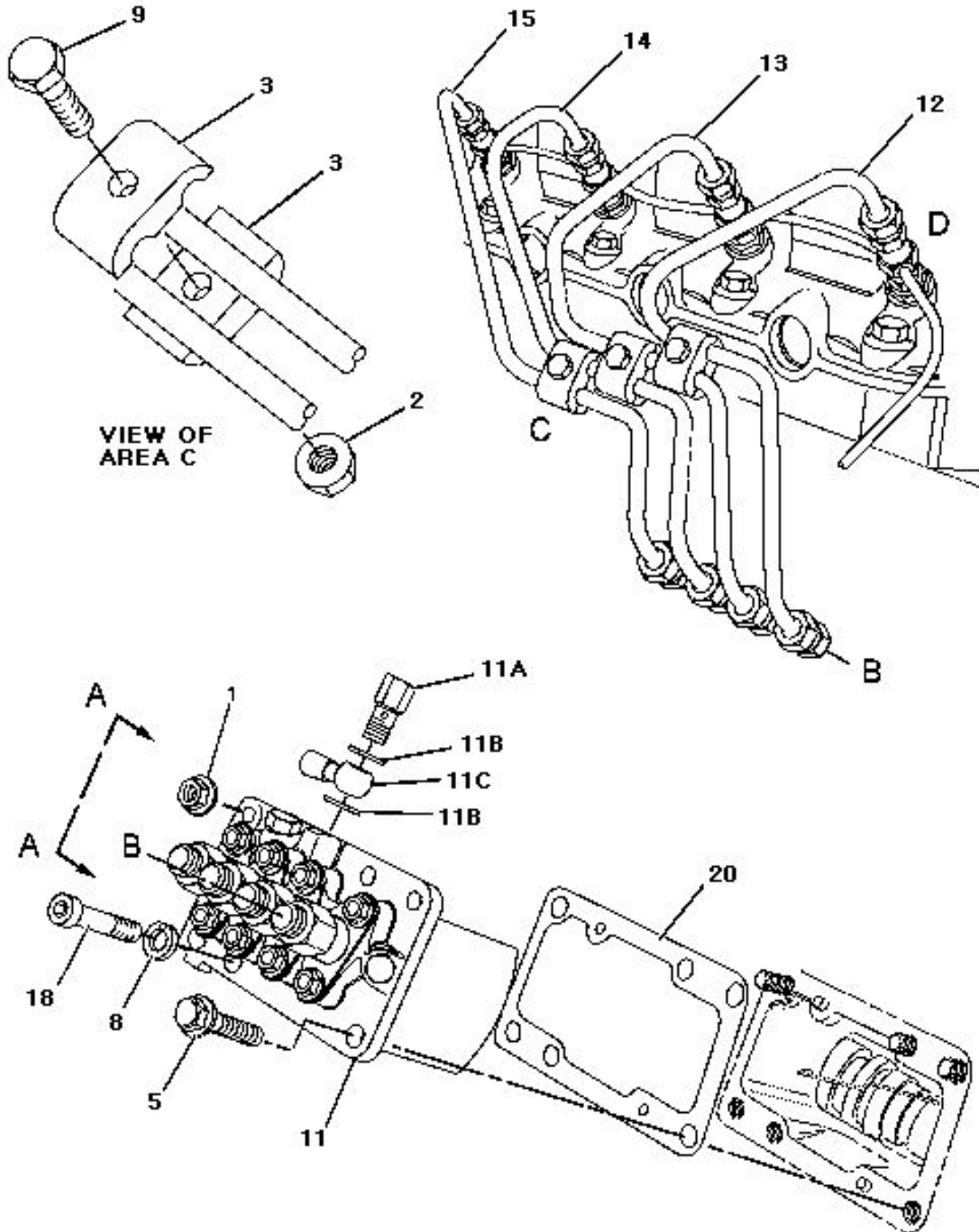

NOTE

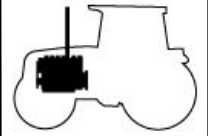

T543/T603

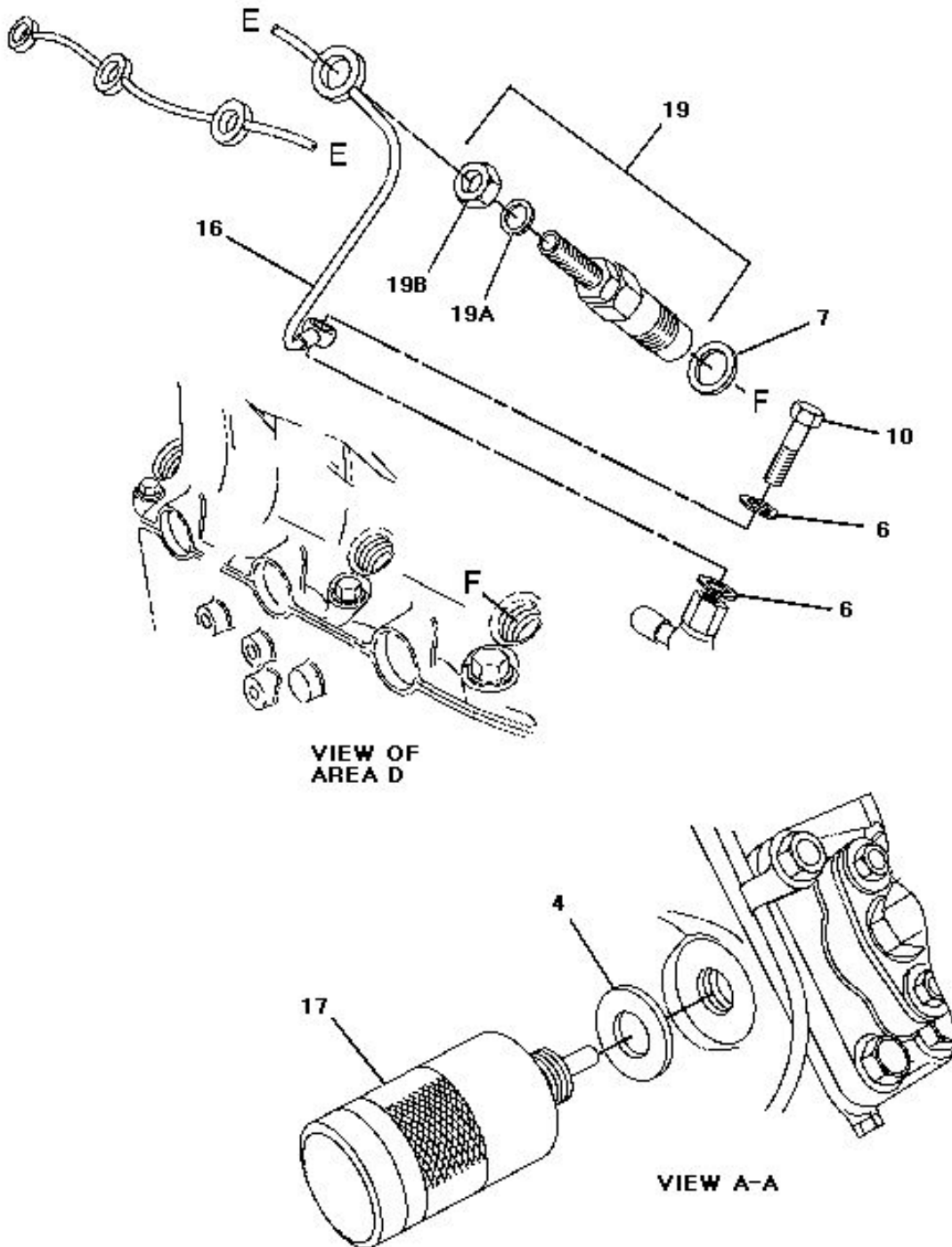

NOTE

FIG 115

FLYWHEEL GROUP

T543/T603

P1

Year / Month

2007 / 02

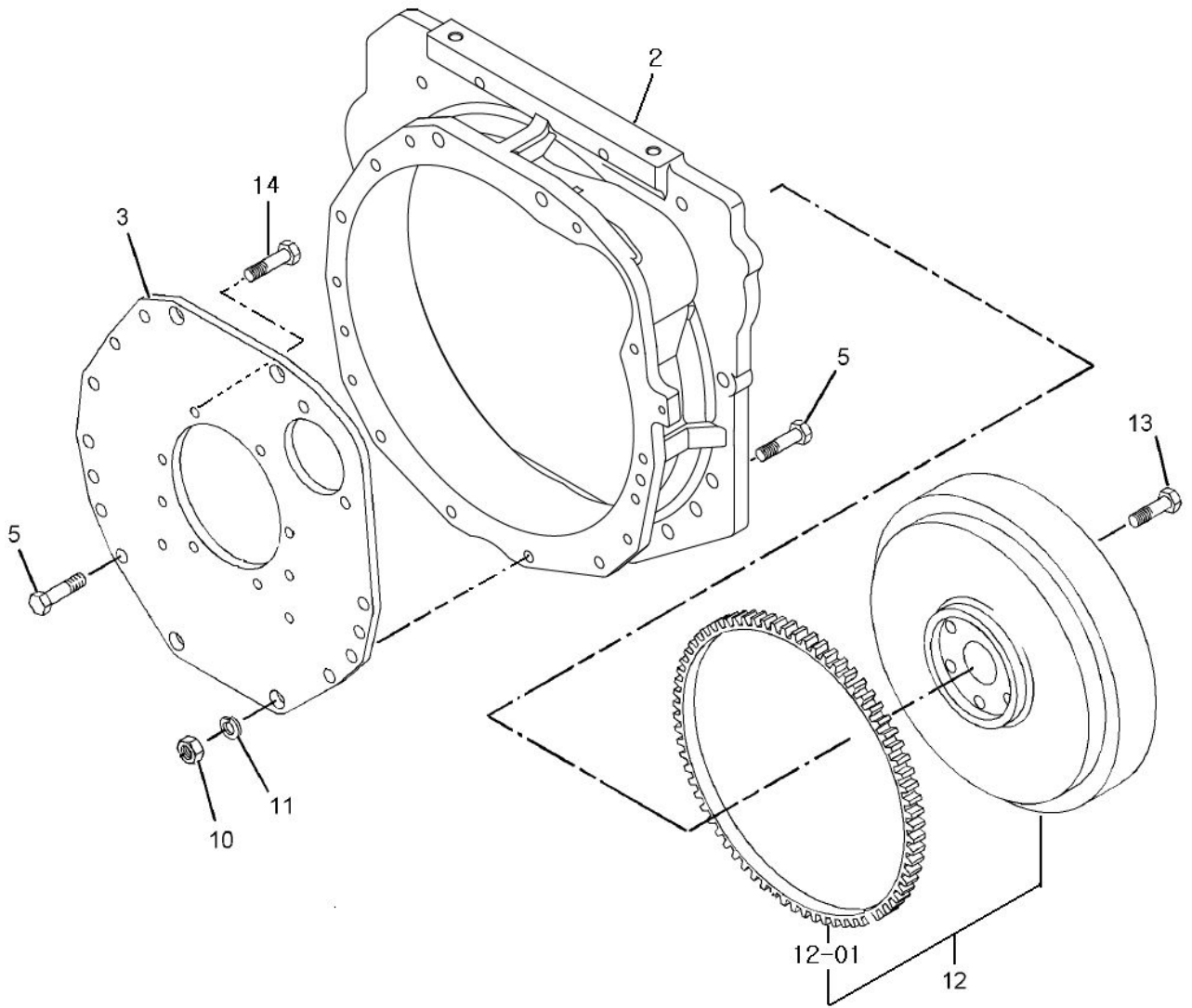

NOTE

FIG 116

T543/T603

ADAPTER GROUP-BEARING

P1

Year / Month

2007 / 02

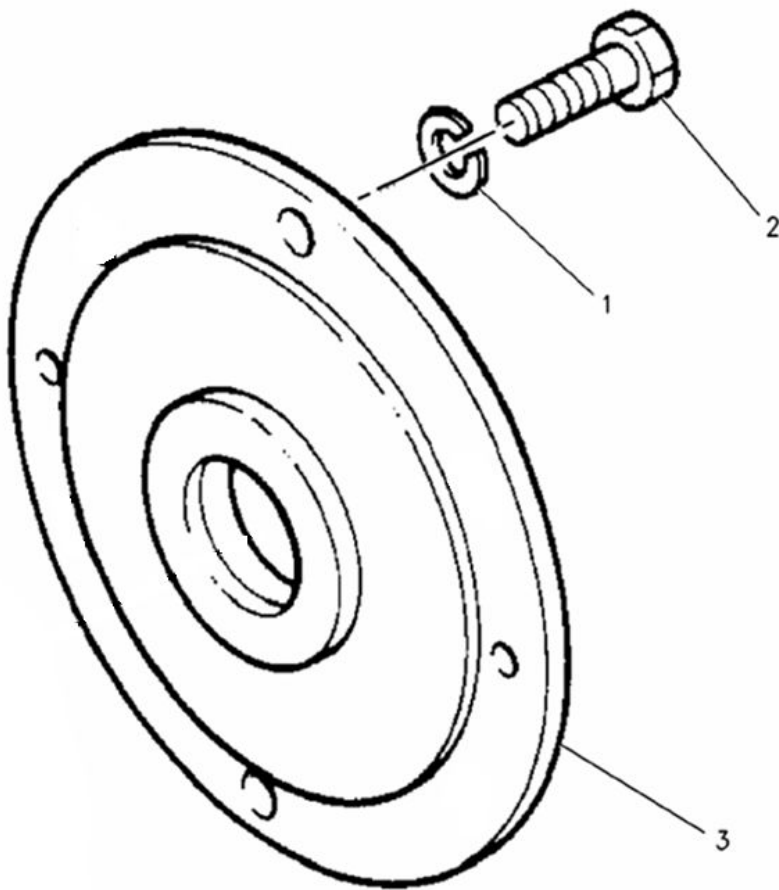
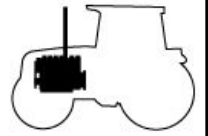

NOTE

FIG 117

PUMP GROUP-WATER (1)

T543/T603

P1

Year / Month

2007 / 02

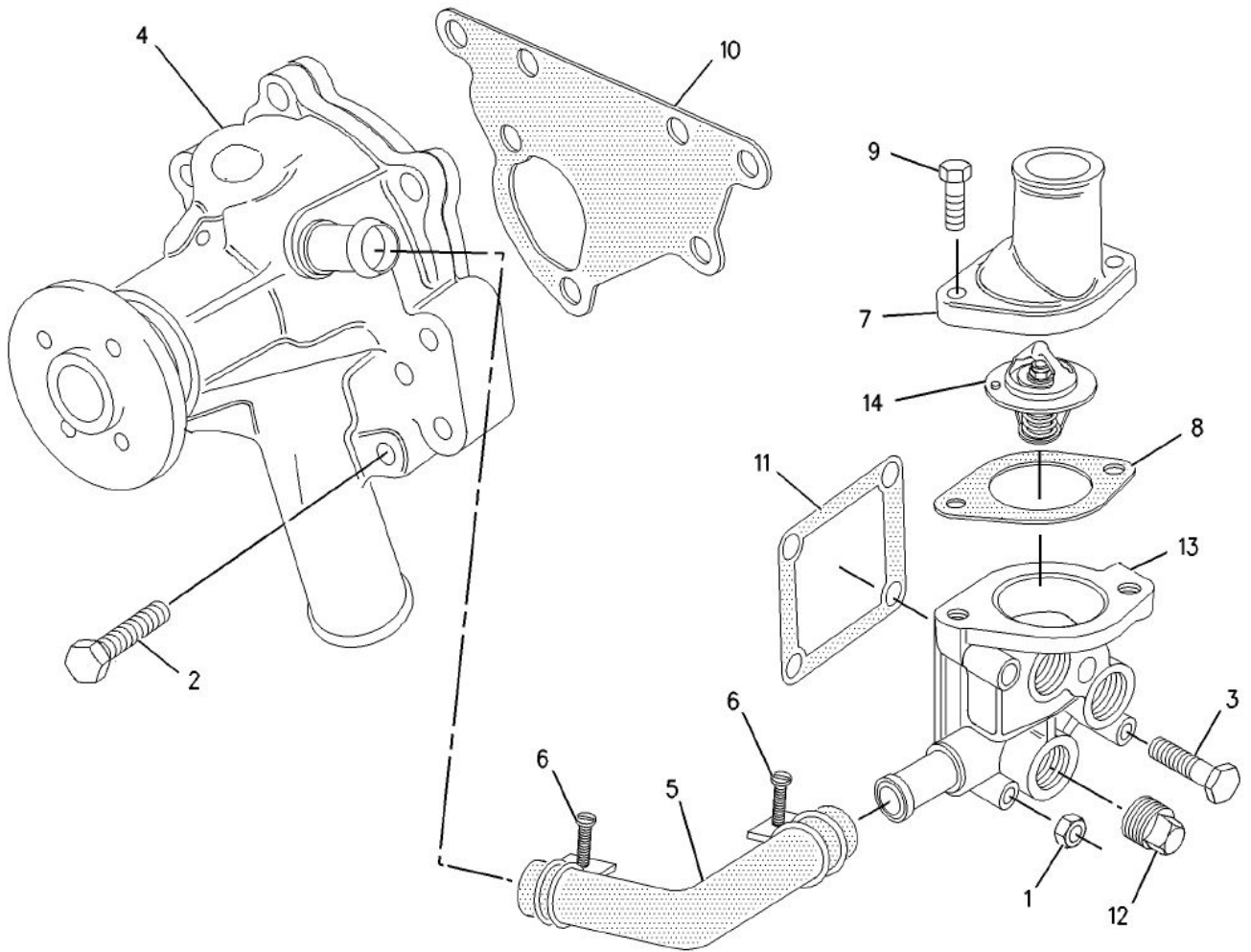
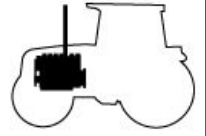

NOTE

FIG 118

PUMP GROUP-WATER (2)

T543/T603

P1

Year / Month

2007 / 02

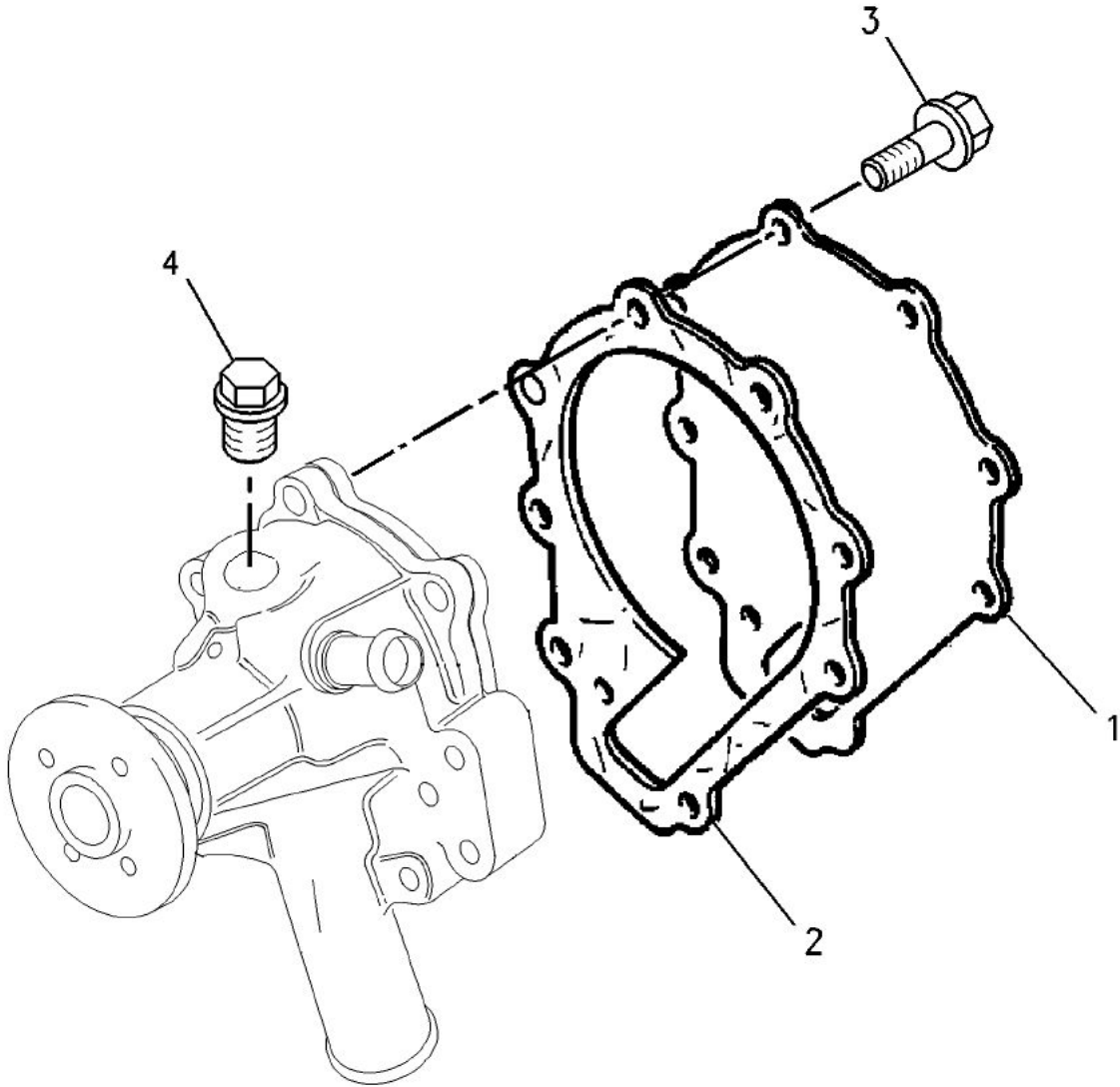
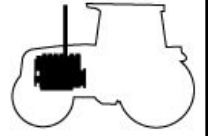

NOTE

FIG 119

COOLER GROUP-FILTER BASE

T543/T603

P1

Year / Month

2007 / 02

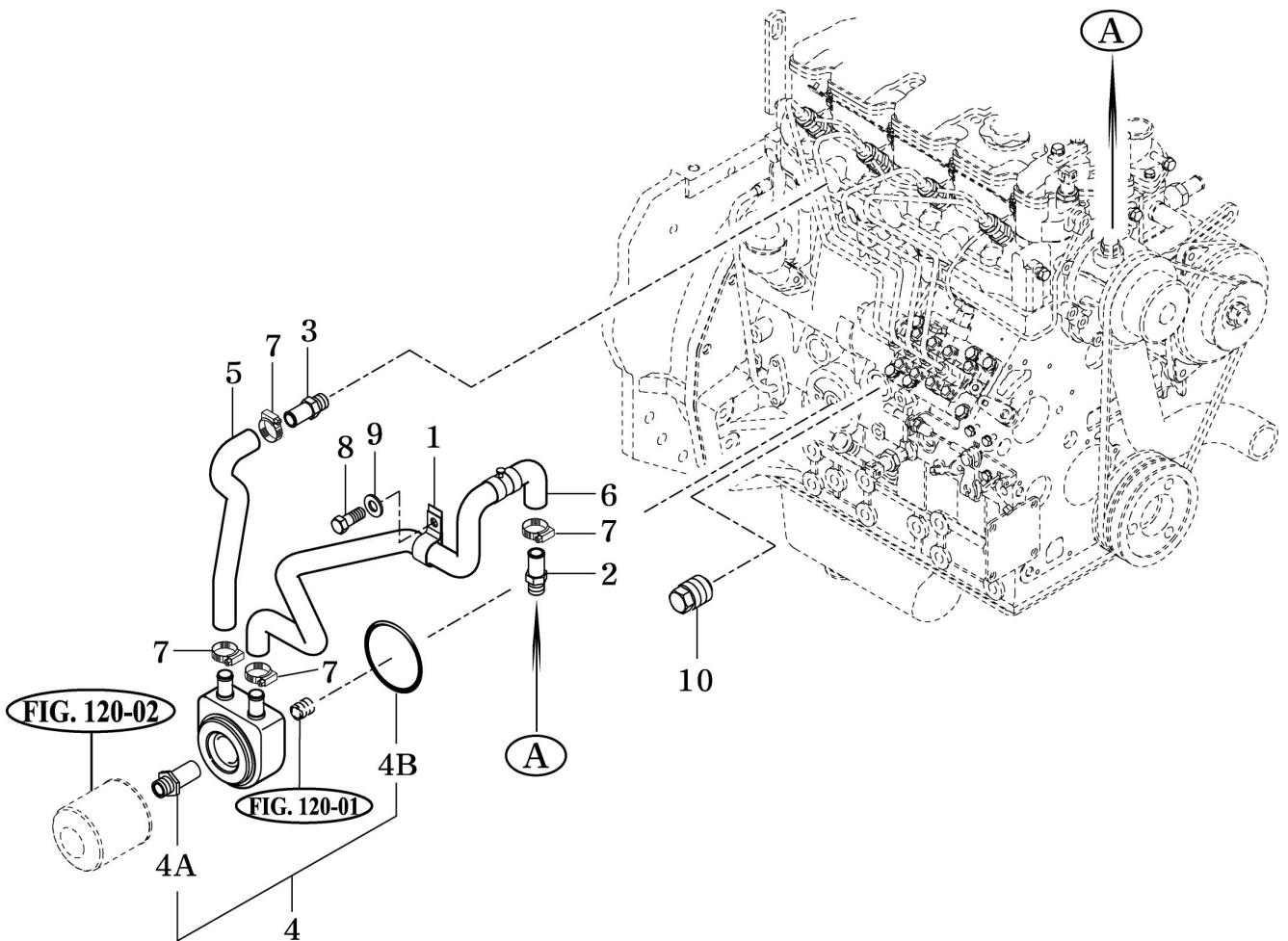
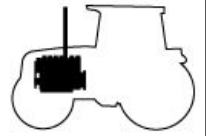

NOTE

FIG 120

T543/T603

ENGINE OIL FILTER

P1

Year / Month

2007 / 02

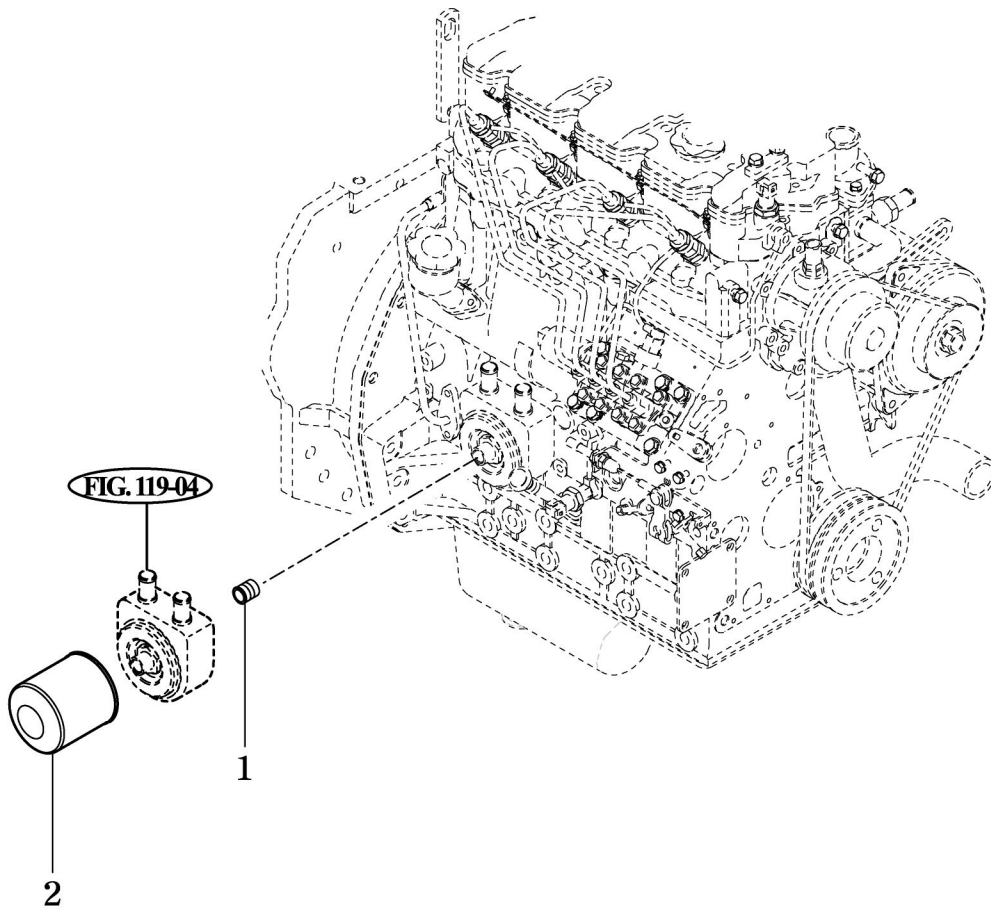

NOTE

FIG 121

FAN GROUP-BLOWER

T543/T603

P1

Year / Month

2007 / 02

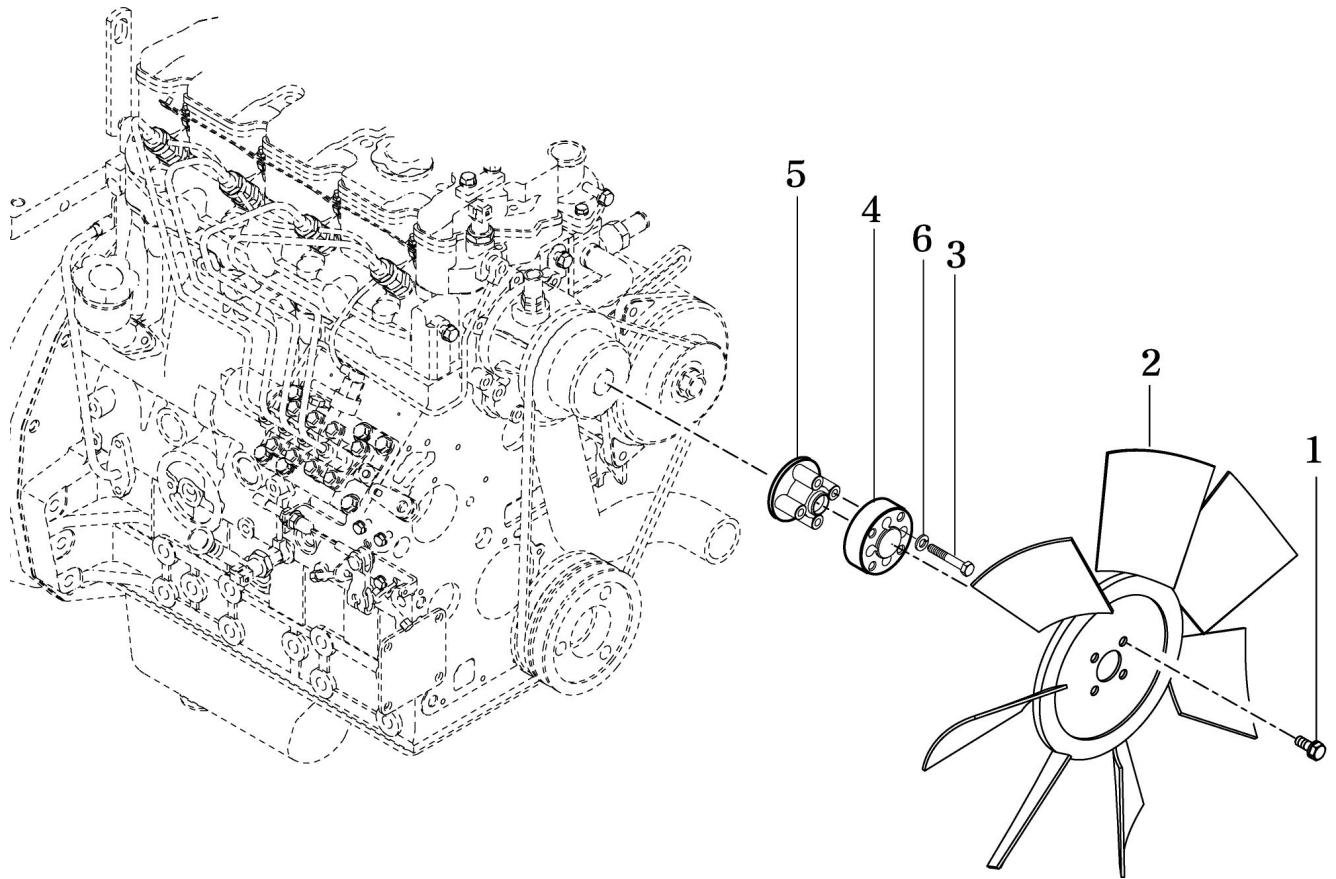

NOTE

FIG 122

PULLEY GROUP-WATER PUMP

T543/T603

P1

Year / Month

2007 / 02

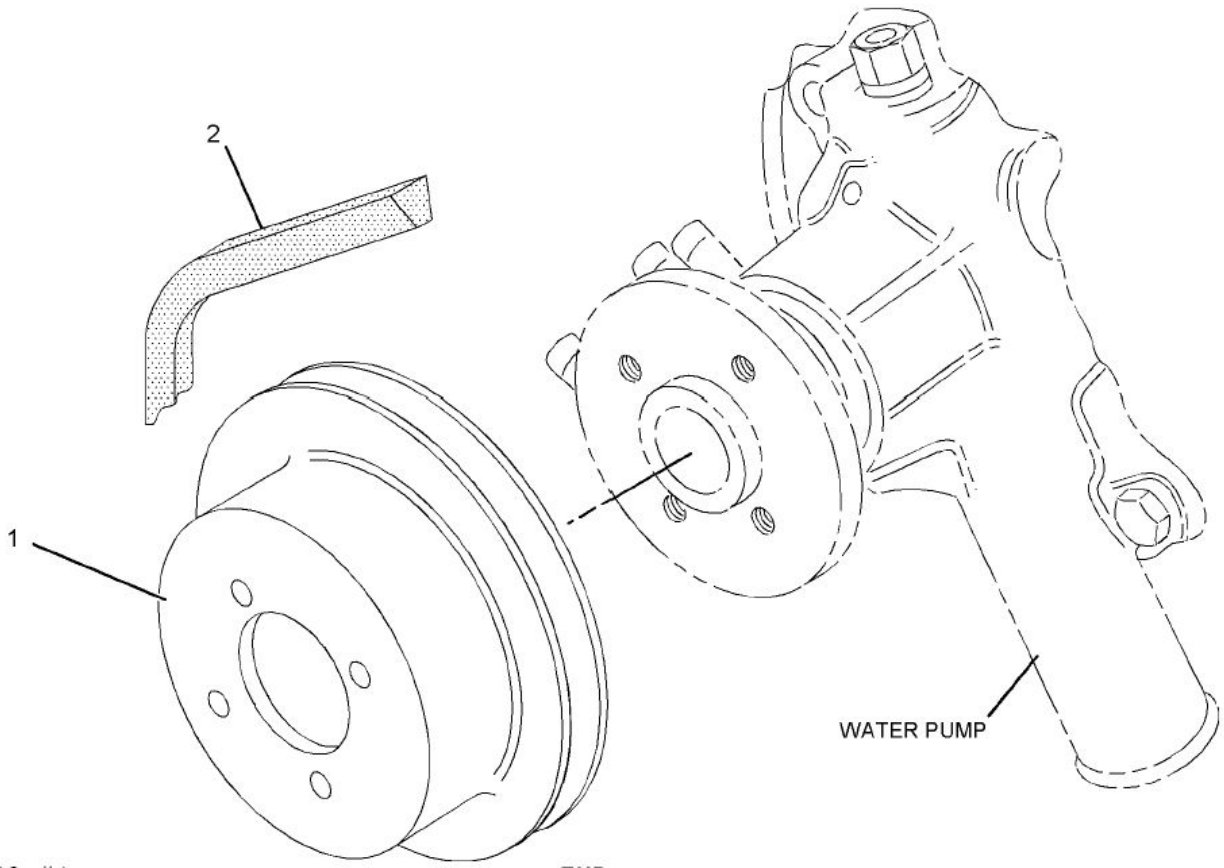
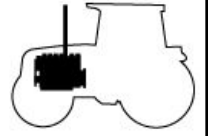

NOTE

FIG 123

SENSOR GROUP-TEMP & PRESS

P1

Year / Month

2007 / 02

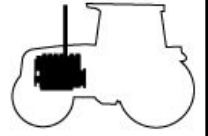

T543/T603

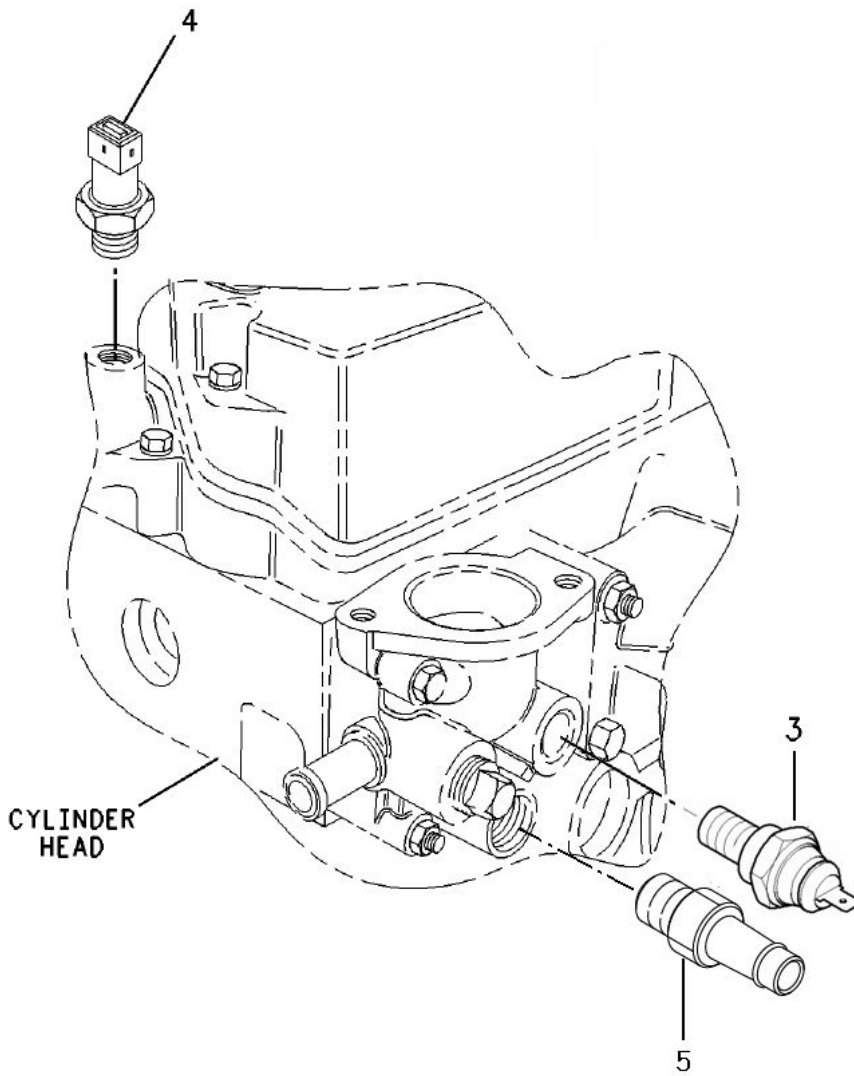

NOTE

FIG 124

MANIFOLD GROUP-EXHAUST

T543/T603

P1

Year / Month

2007 / 02

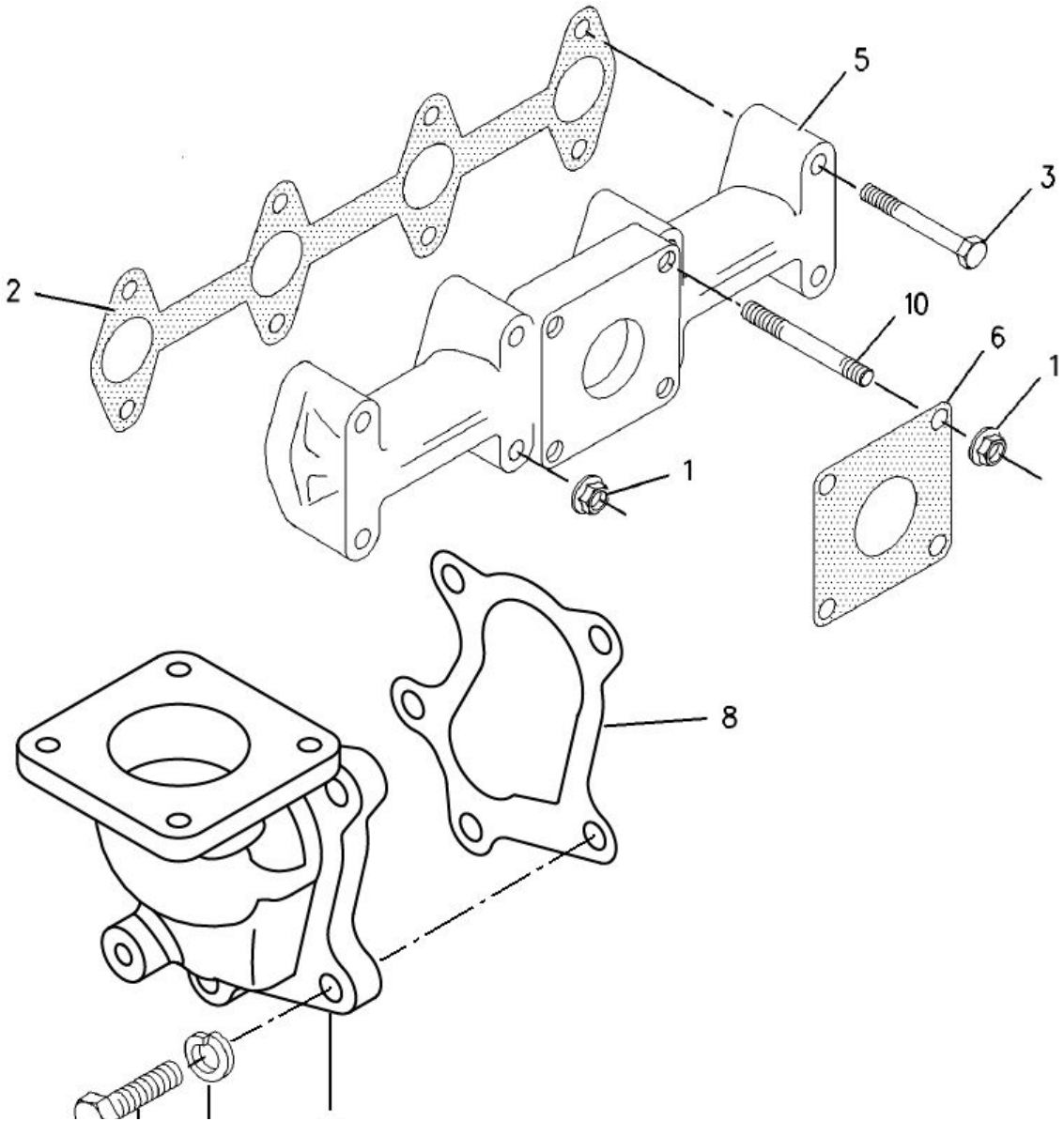

NOTE

FIG 125

TURBOCHARGER GROUP

T543/T603

P1

Year / Month

2007 / 02

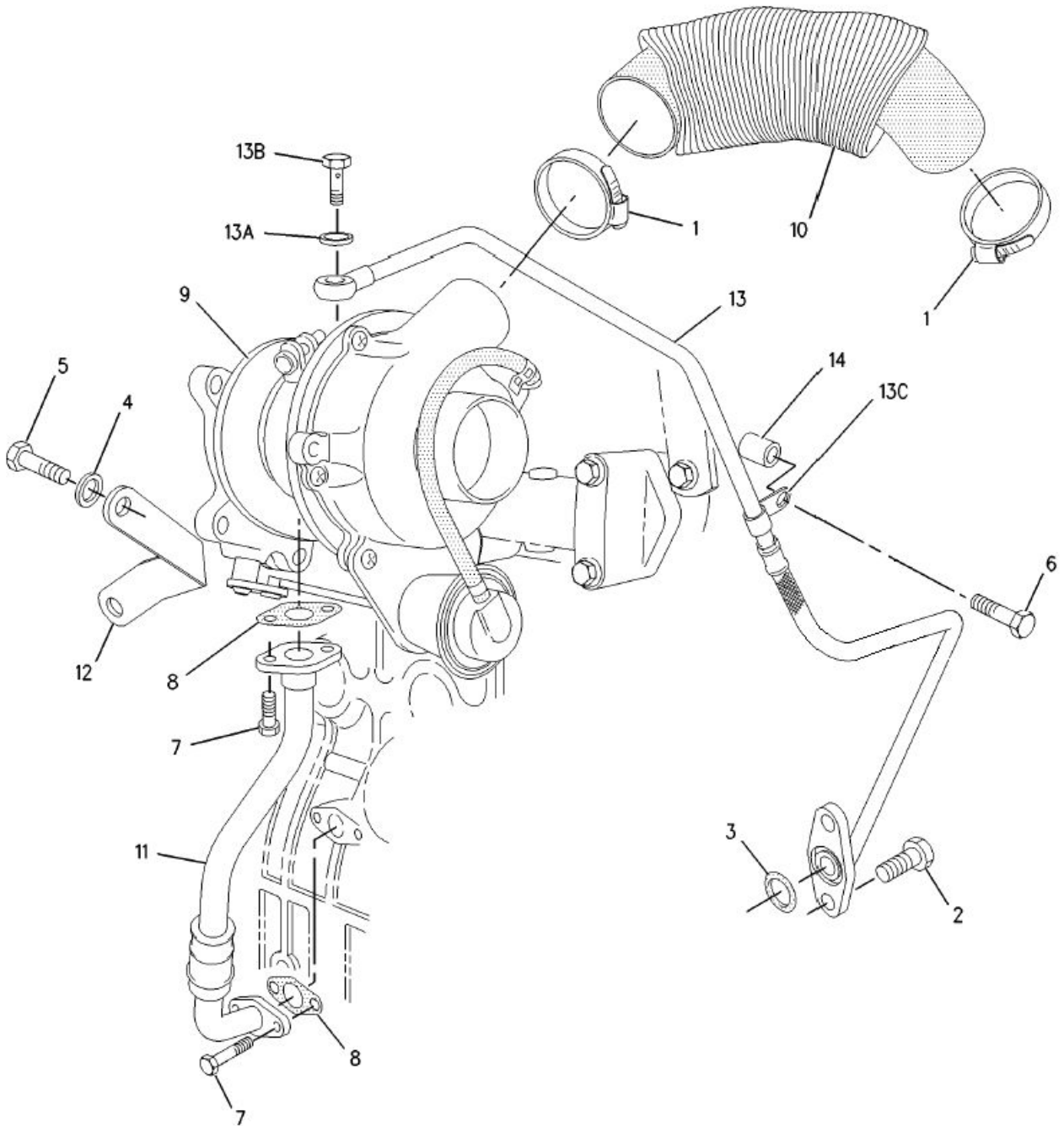
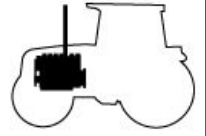

NOTE

FIG 126

FILLER GROUP-ENGINE OIL

T543/T603

P1

Year / Month

2007 / 02

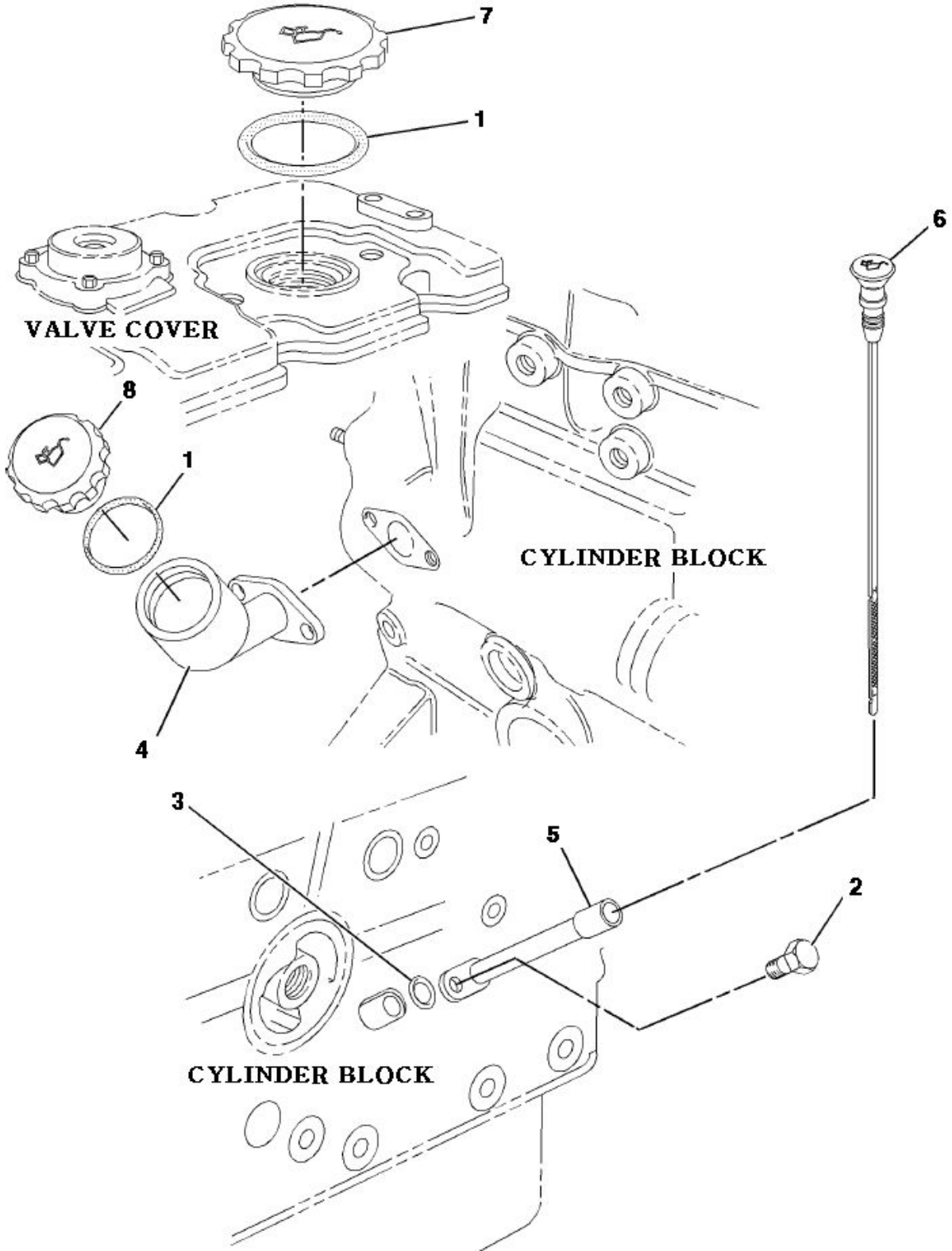
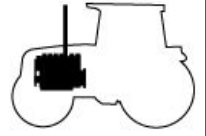

NOTE

FIG 127

T543/T603

MOUNTING GROUP-ENGINE OIL FILLER

P1

Year / Month

2007 / 02

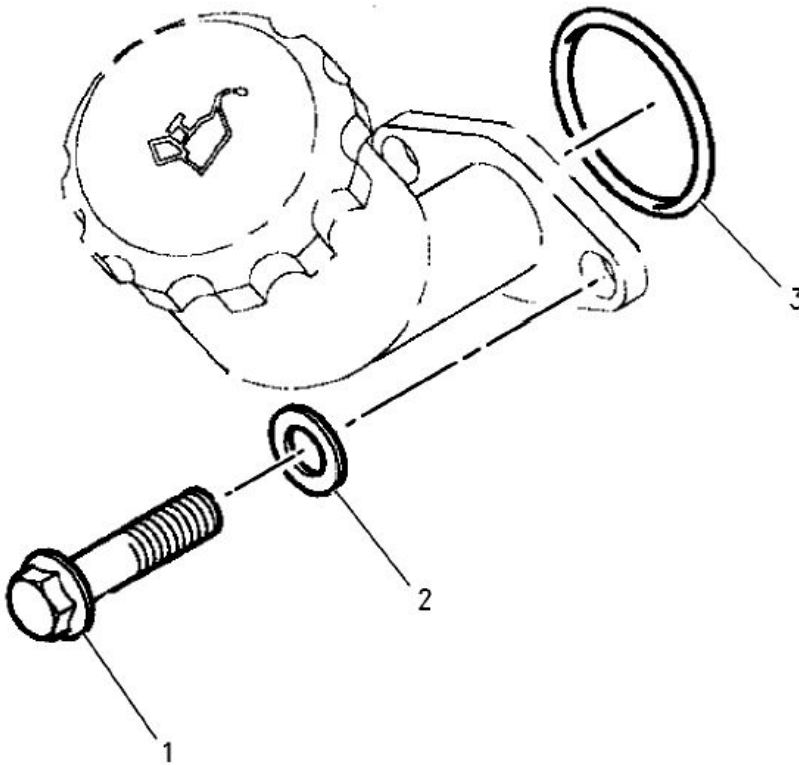
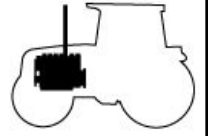

NOTE

FIG 129

ALTERNATOR GROUP-CHARGING

P1

Year / Month

2007 / 02

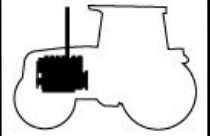

T543/T603

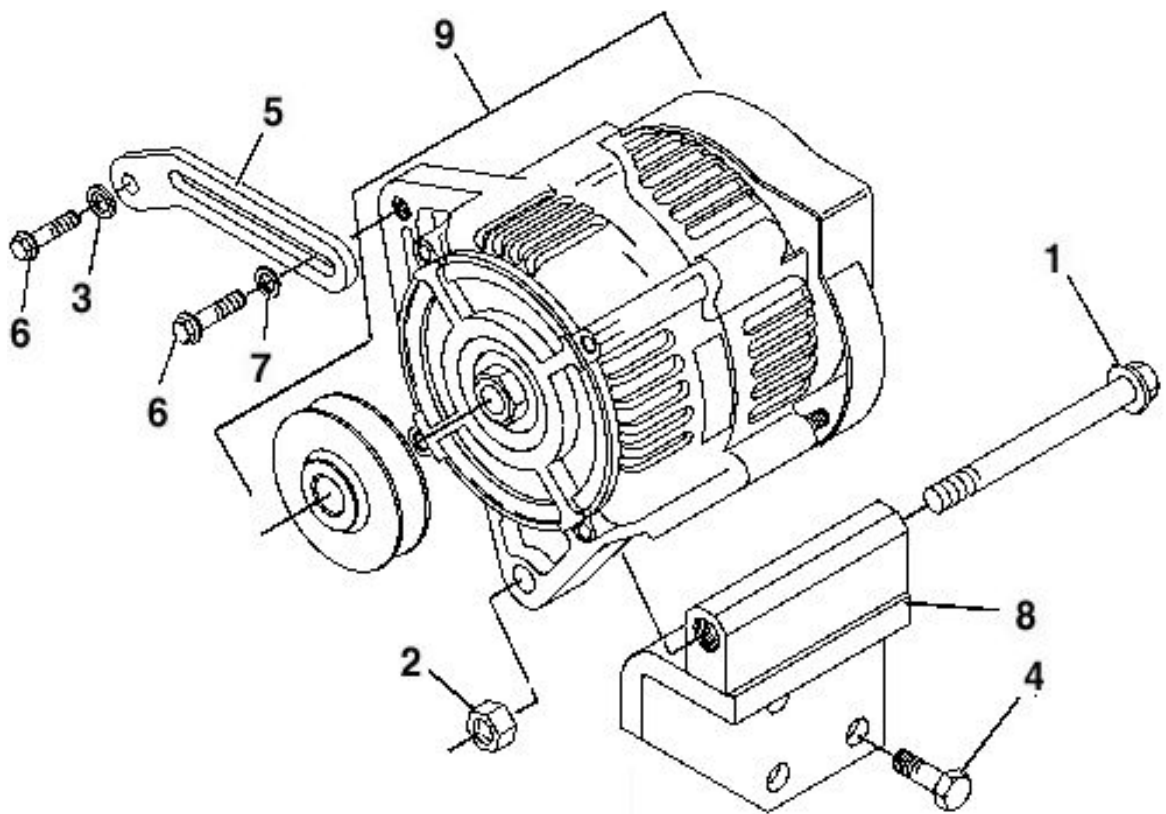

NOTE

FIG 130

T543/T603

STARTING MOTOR GROUP-ELECTRIC

P1

Year / Month

2007 / 02

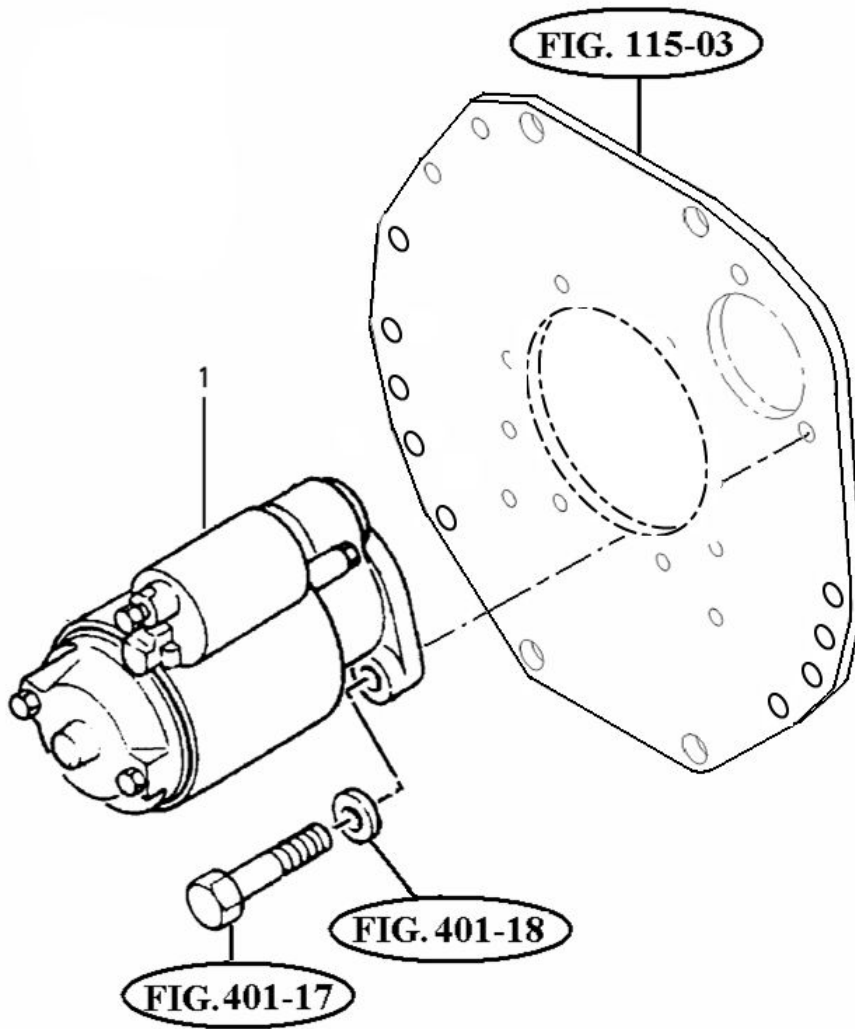

NOTE

FIG 131

T543/T603

LIFTING GROUP-ENGINE

P1

Year / Month

2007 / 02

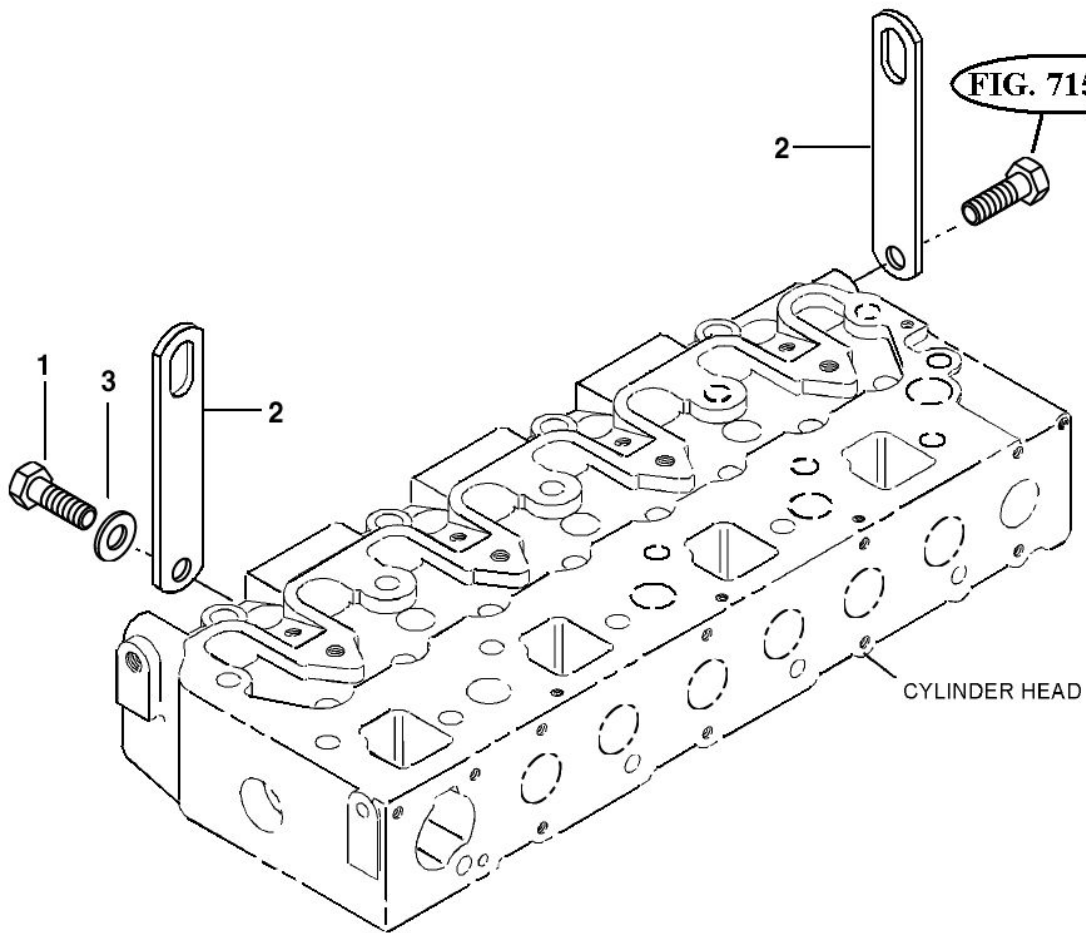
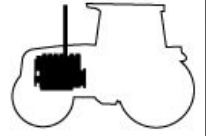

NOTE

FIG 132

FILTER & LINES GROUP-FUEL

T543/T603

P1

Year / Month

2007 / 02

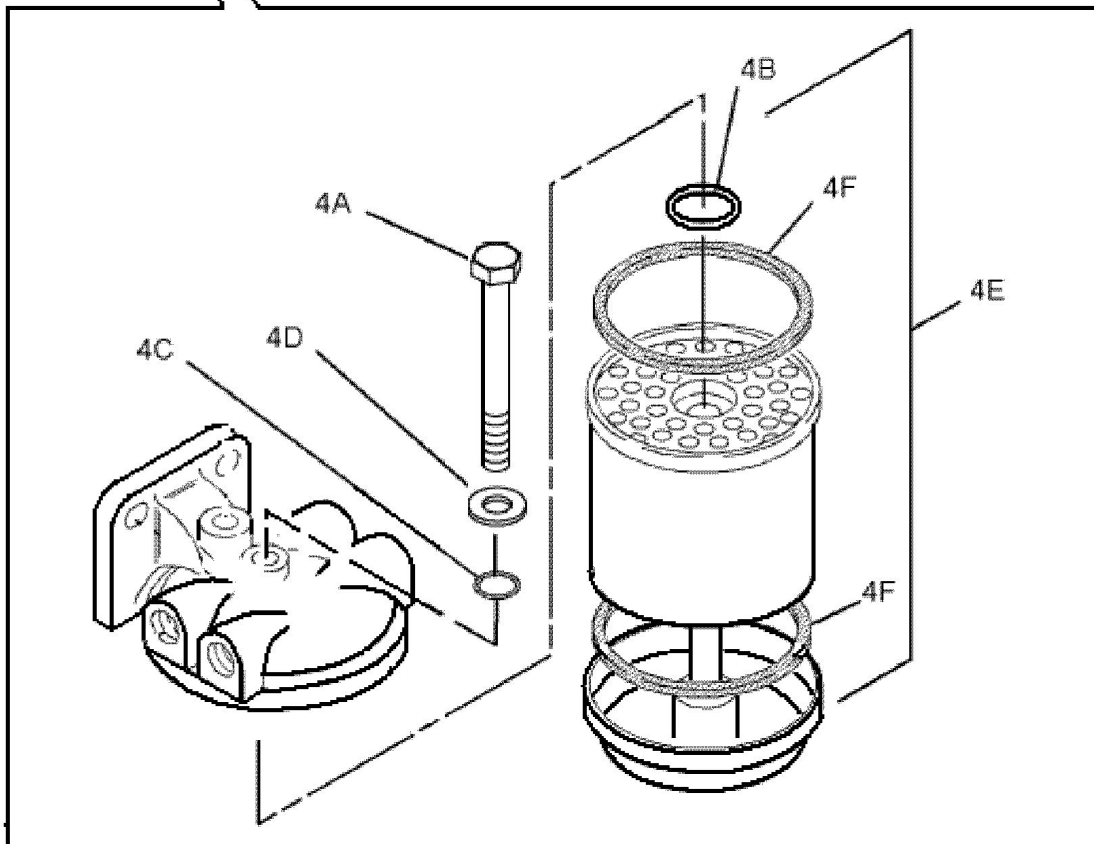
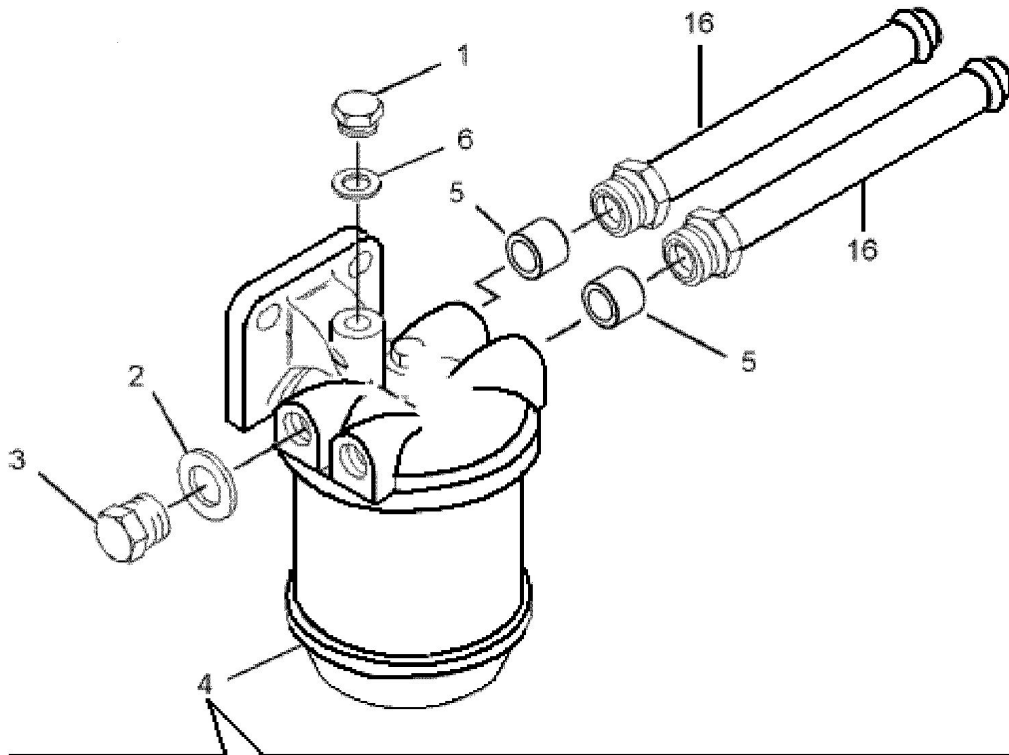
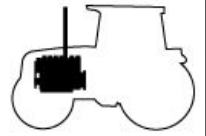

NOTE

FIG 133

GLOW PLUG GROUP

T543/T603

P1

Year / Month

2007 / 02

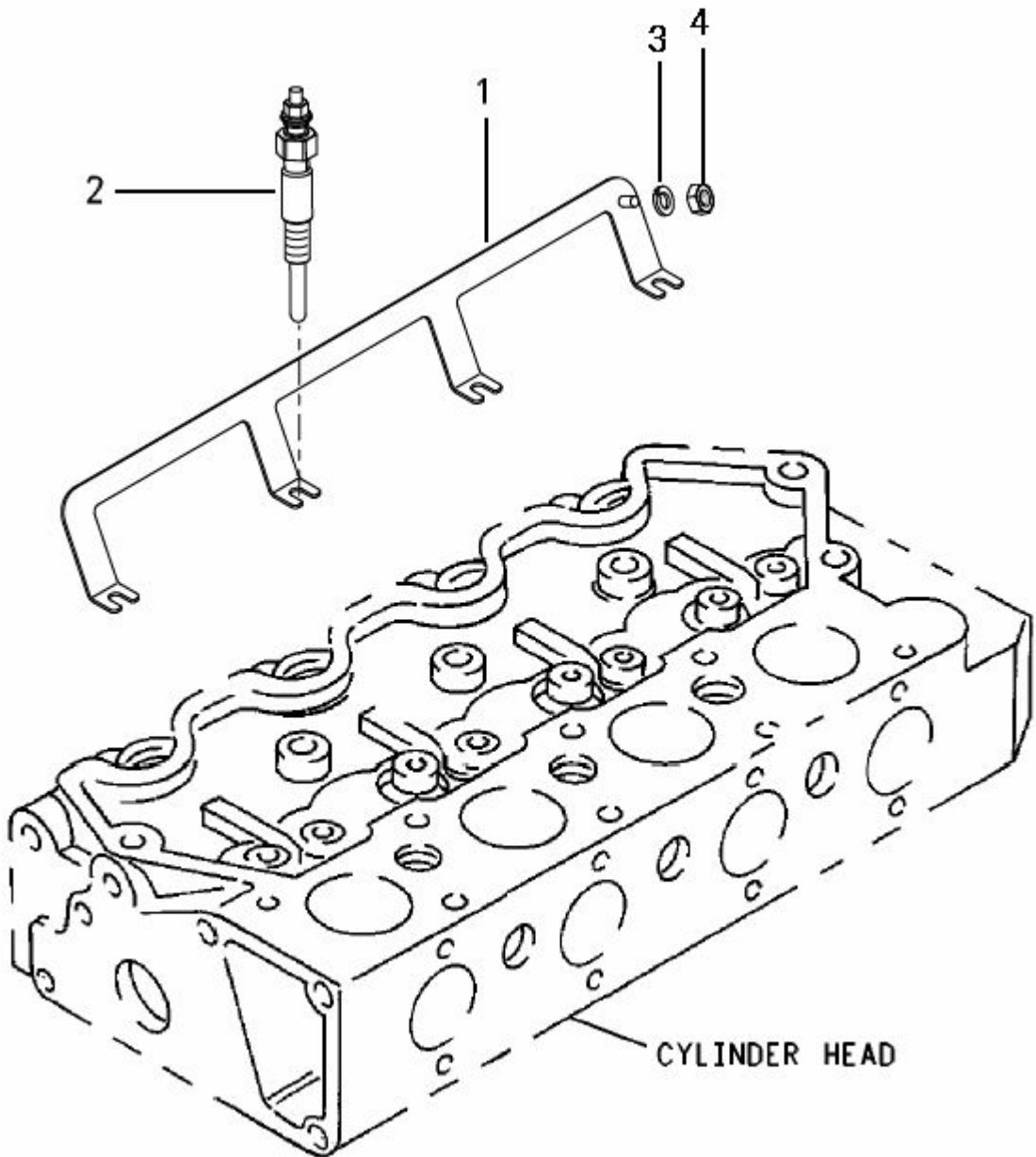
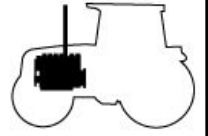

NOTE