

1: 5V  
0: GND

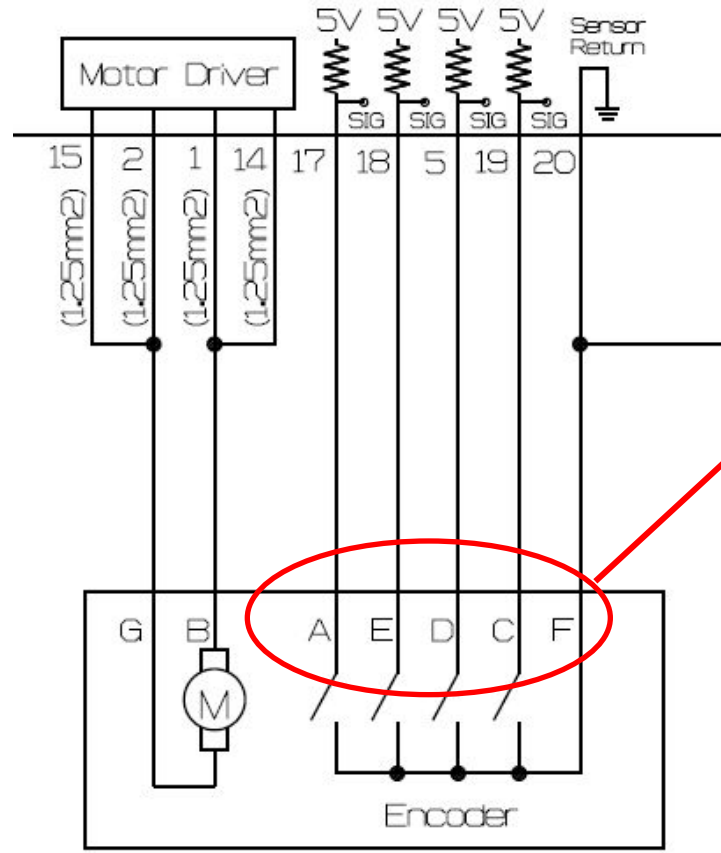

T/C SHIFT MOTOR

ITEM	POSITION	2H	4H	4L
A	POS_4	0	1	0
E	POS_1	1	0	1
D	POS_2	0	0	1
C	POS_3	1	1	0
F	POS_RETURN	0	0	0

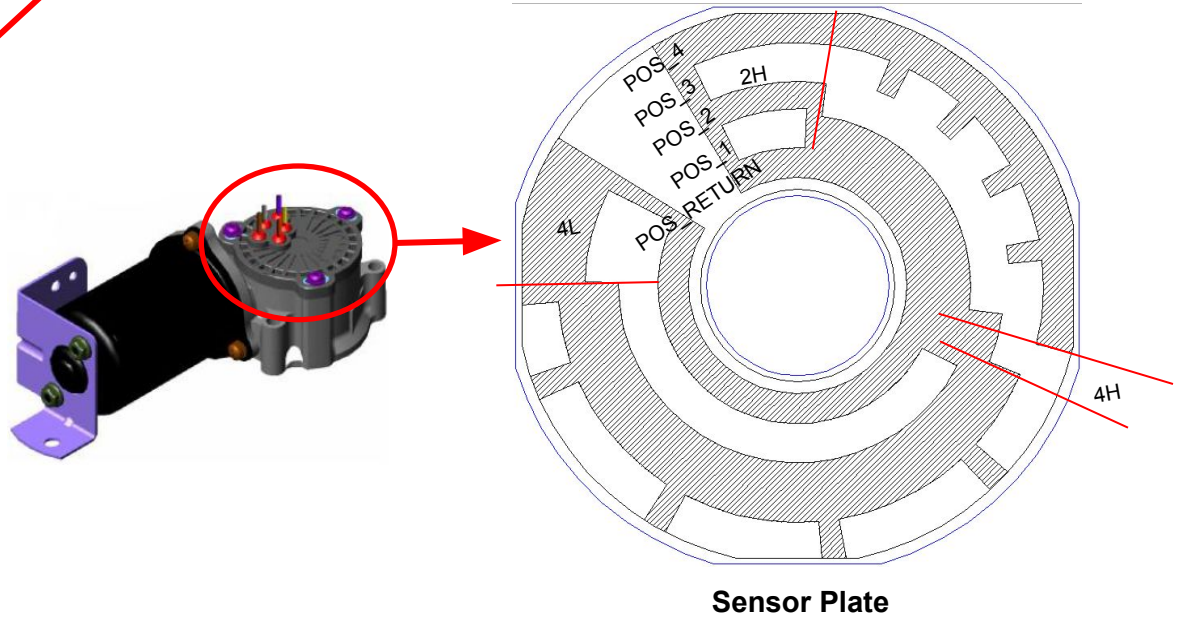

Sensor Plate