

Гусеница



Открытая тема

Гусеницы имеют мягкое вытянутое тело. Крыльев у них нет. Многие имеют яркую окраску и красивое опушение или выросты. Питаются в основном растительной пищей.

Гусеница - это злостный вредитель. У неё много врагов. Она является особым лакомством для птиц, но с помощью различных уловок им удается спастись от гибели. Некоторые гусеницы похожи на ветки и сучки, а другие маскируются под цвет листьев. Гусеница раковидного мотылька способна даже обрызгать врага кислотой.

Достигнув определённого возраста, гусеницы окукливаются и скоро превращаются в прекрасное создание - бабочку.



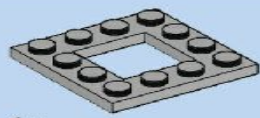

1x

1

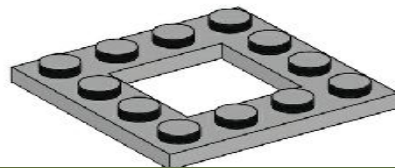

1x



2x

2

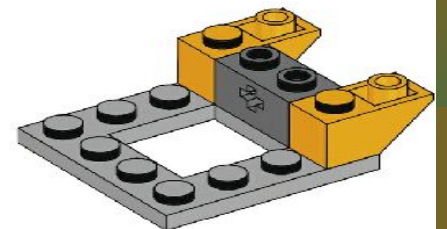

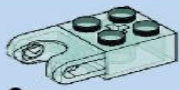

2x

3

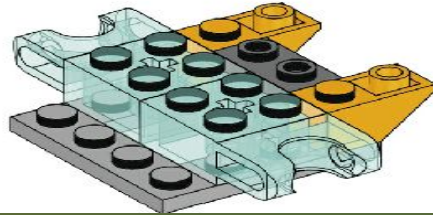

1x



2x

4

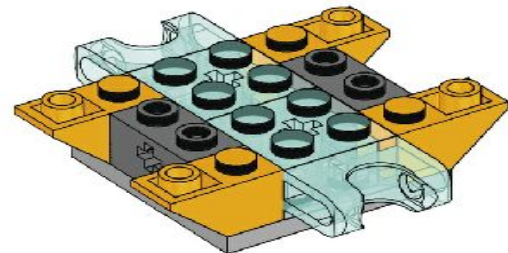

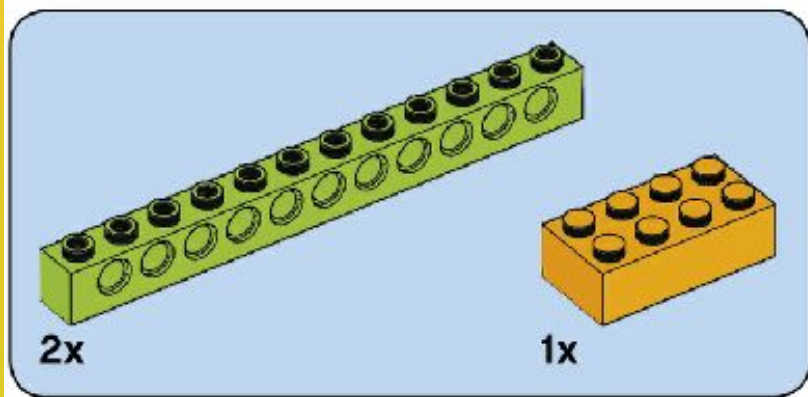

5

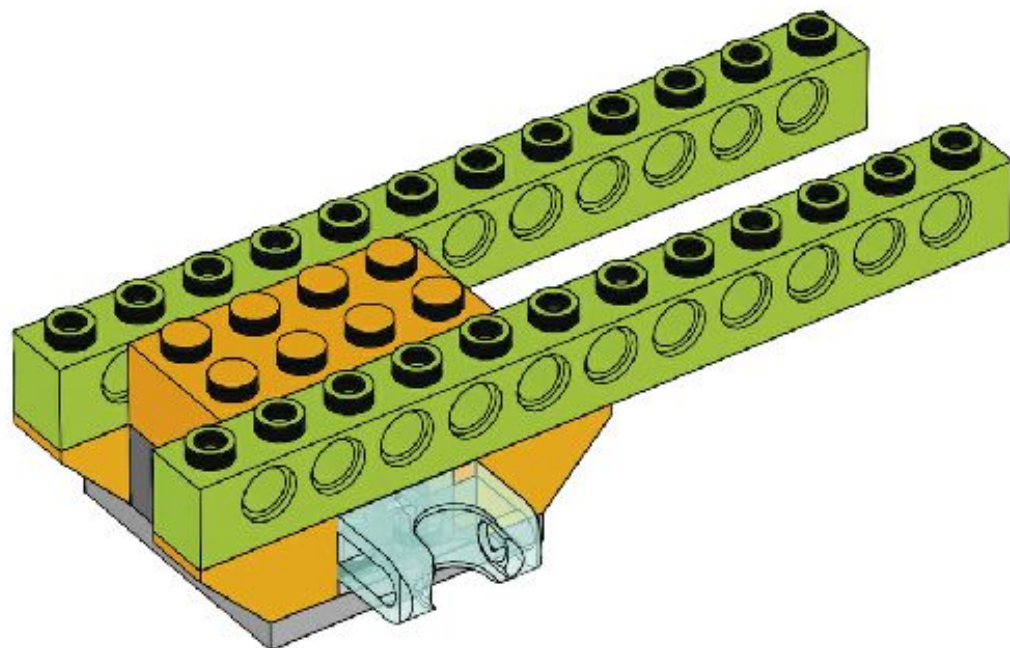

6

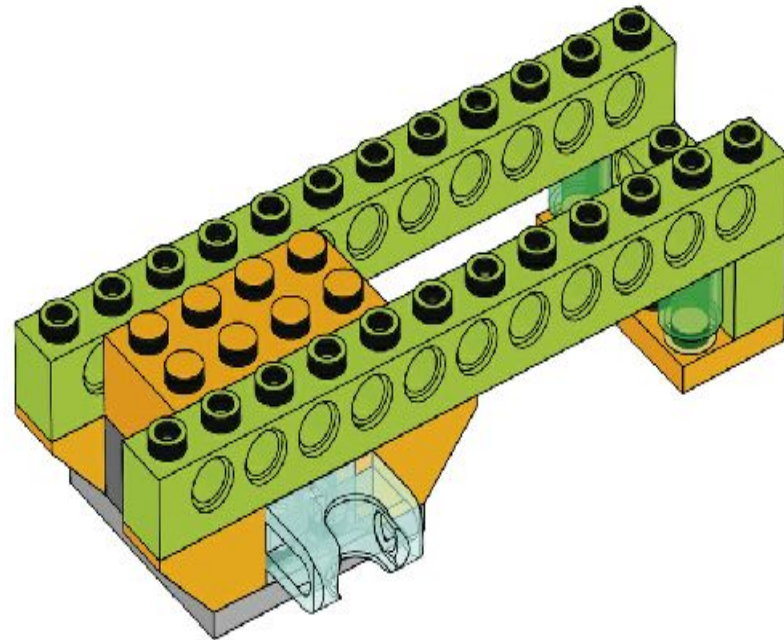
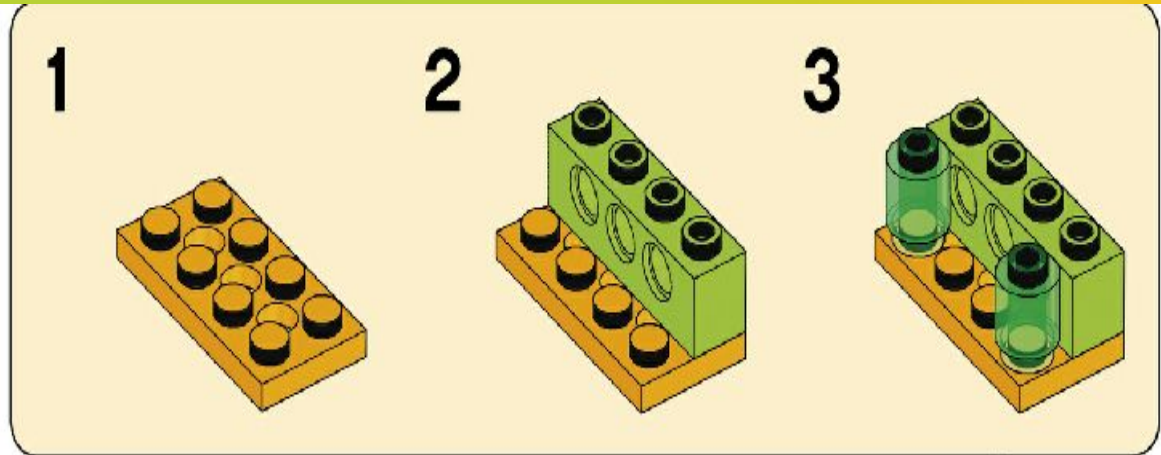
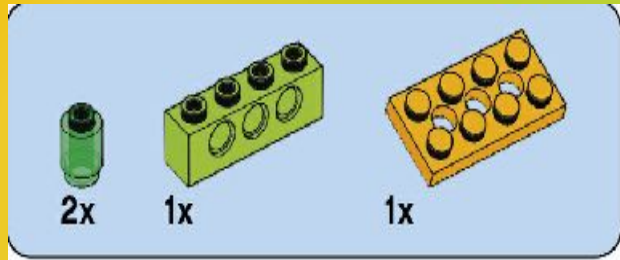

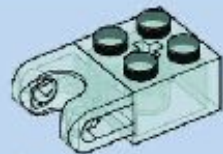

1x

7

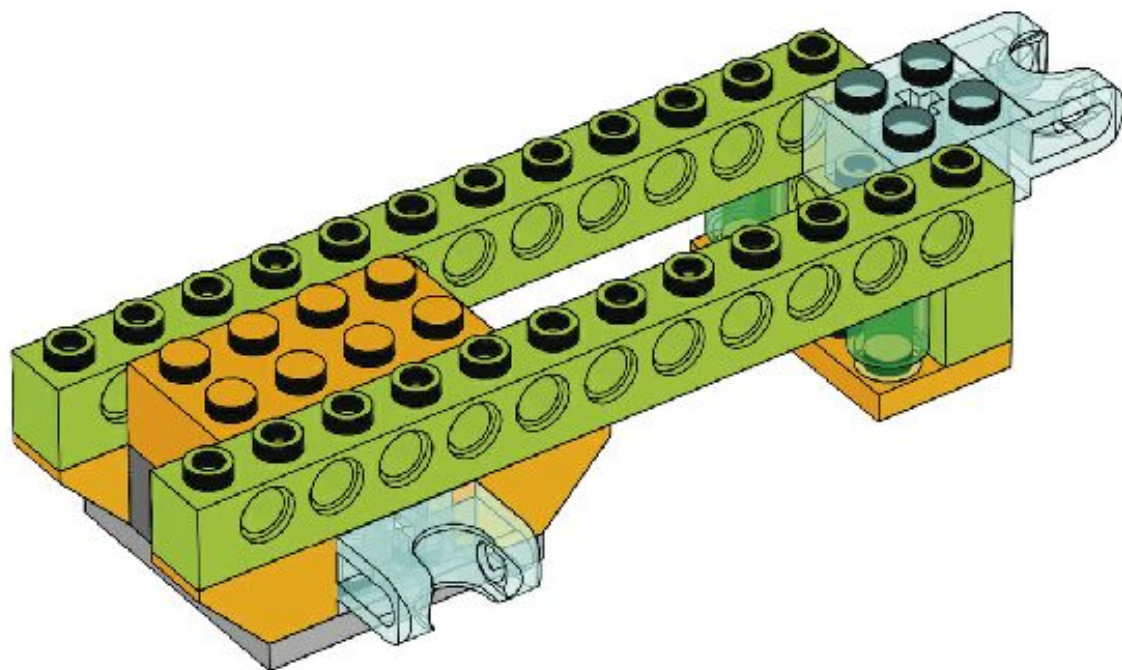



2x

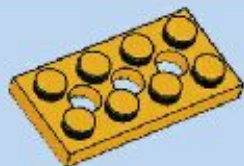

1x

8

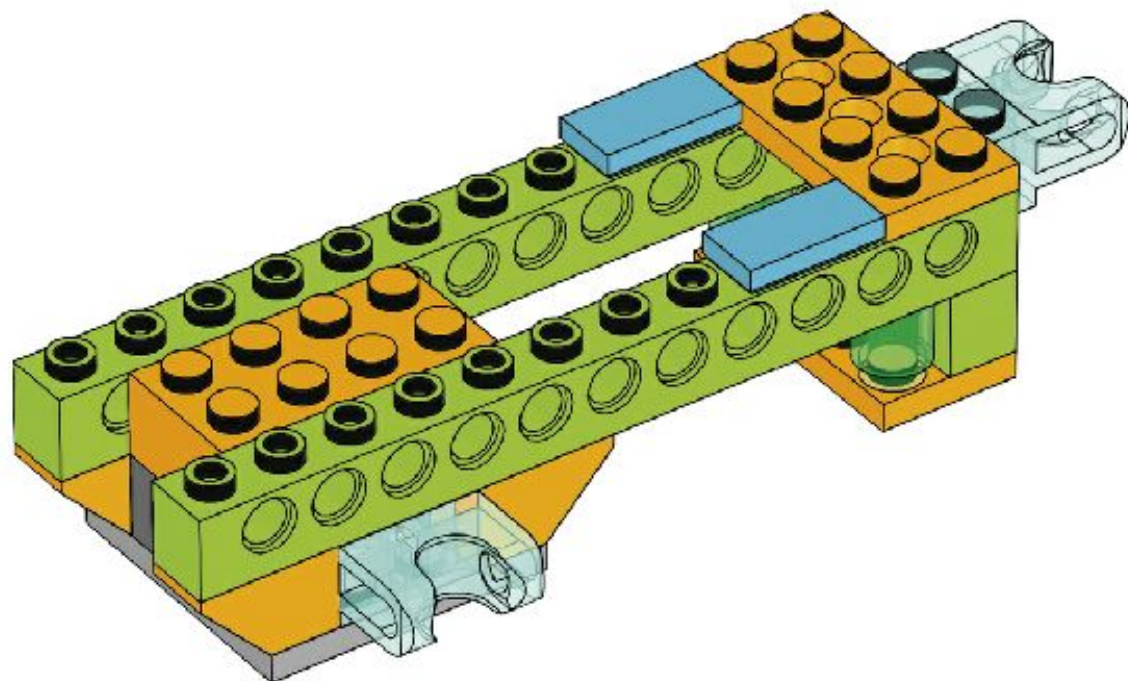

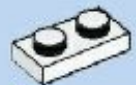

1x



1x

9

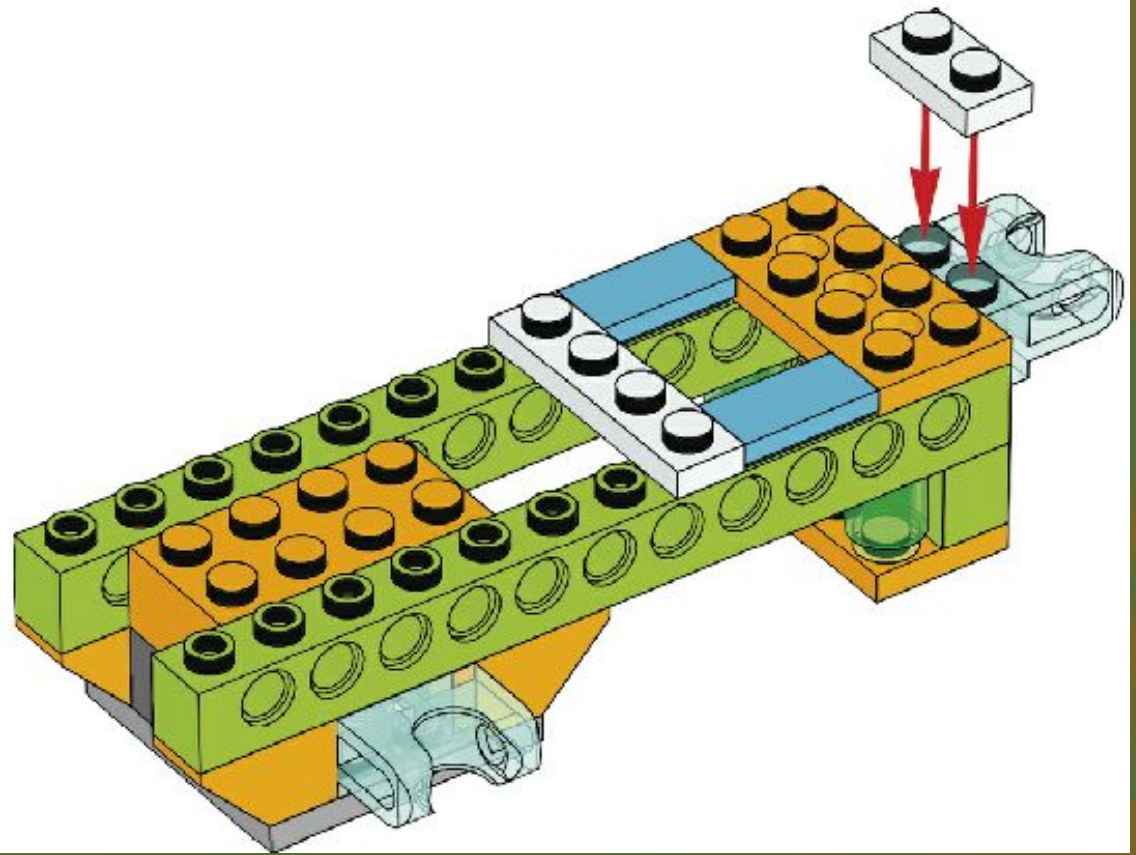

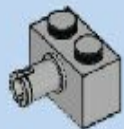

4x

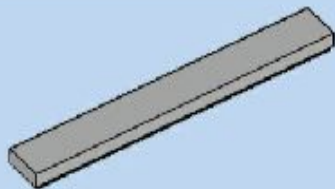

2x

10

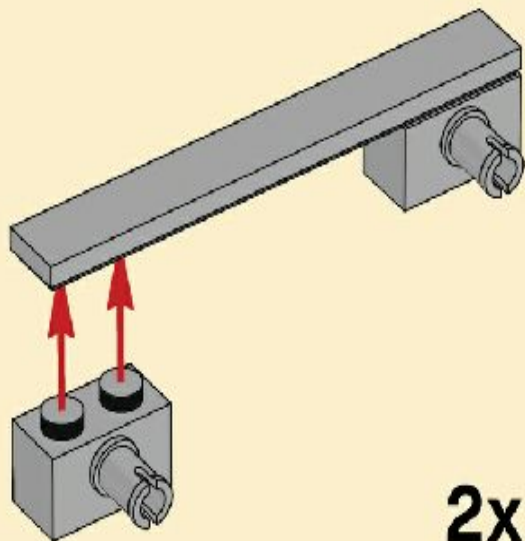

2x

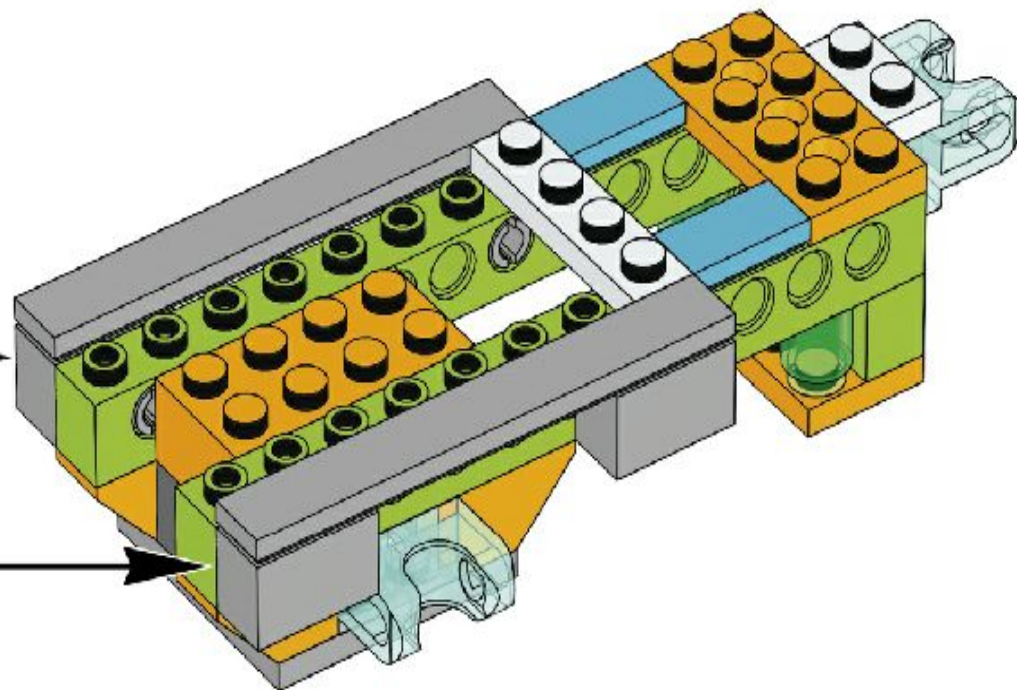



1x

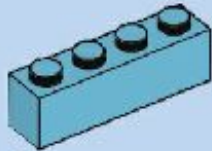

2x

11

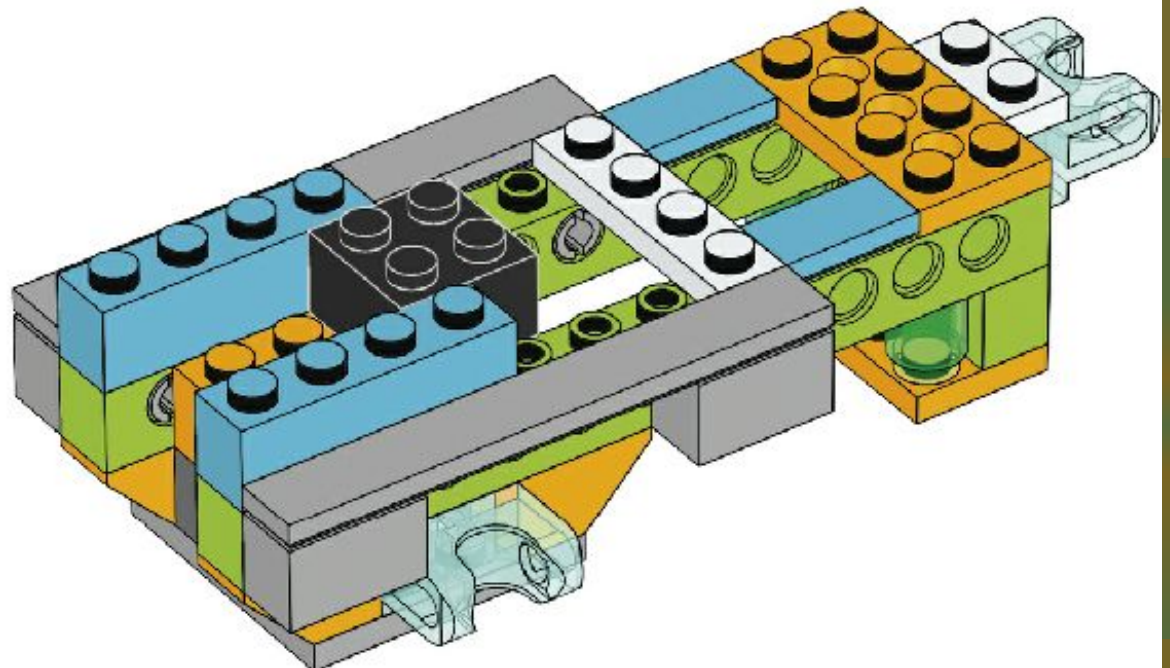

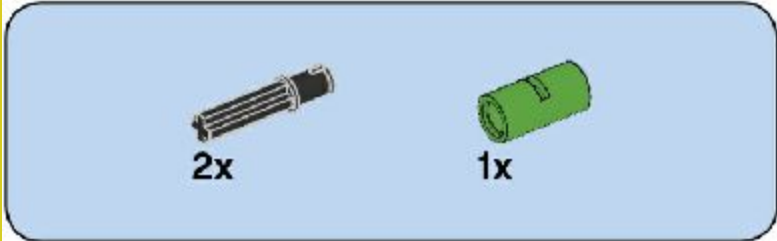

12

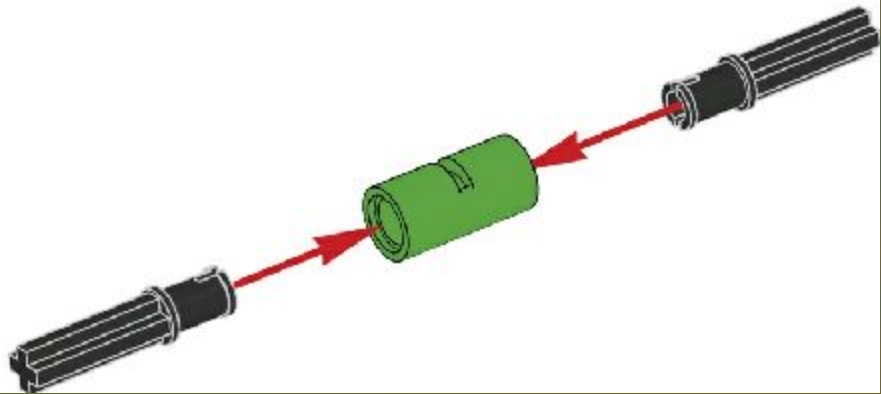



1x

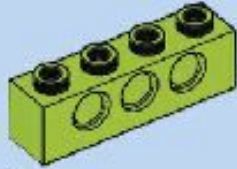

1x

13

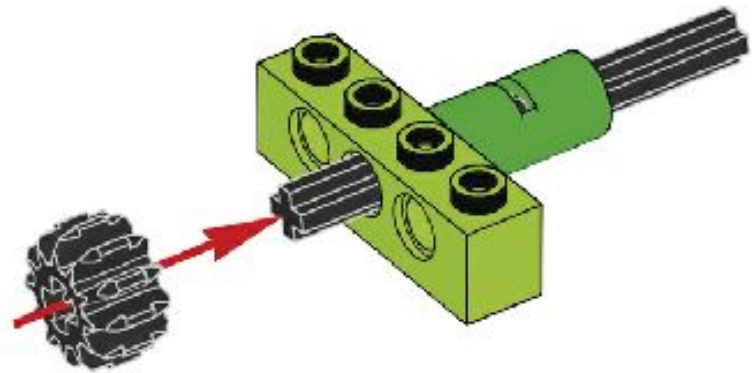



1x

14

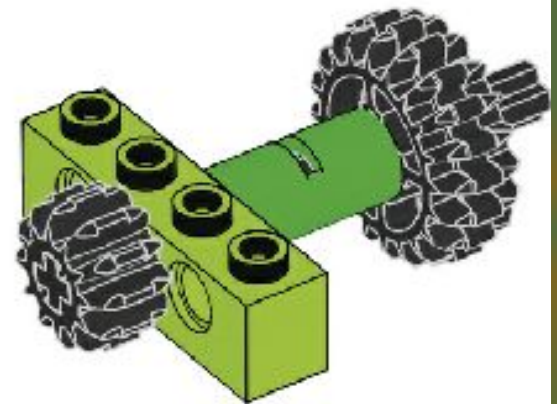

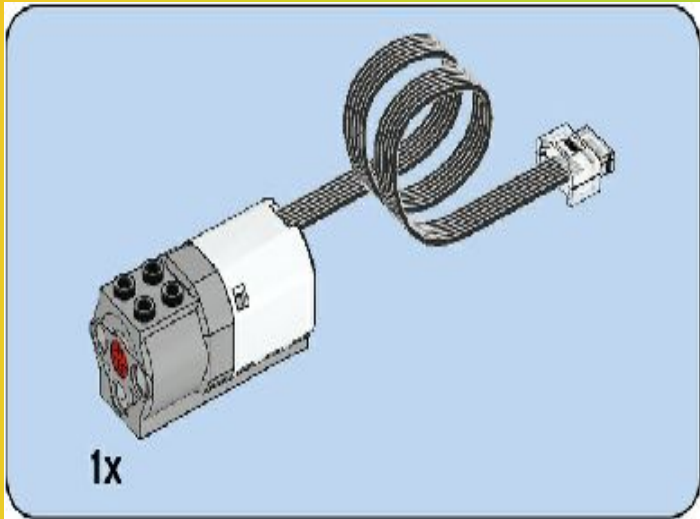

15

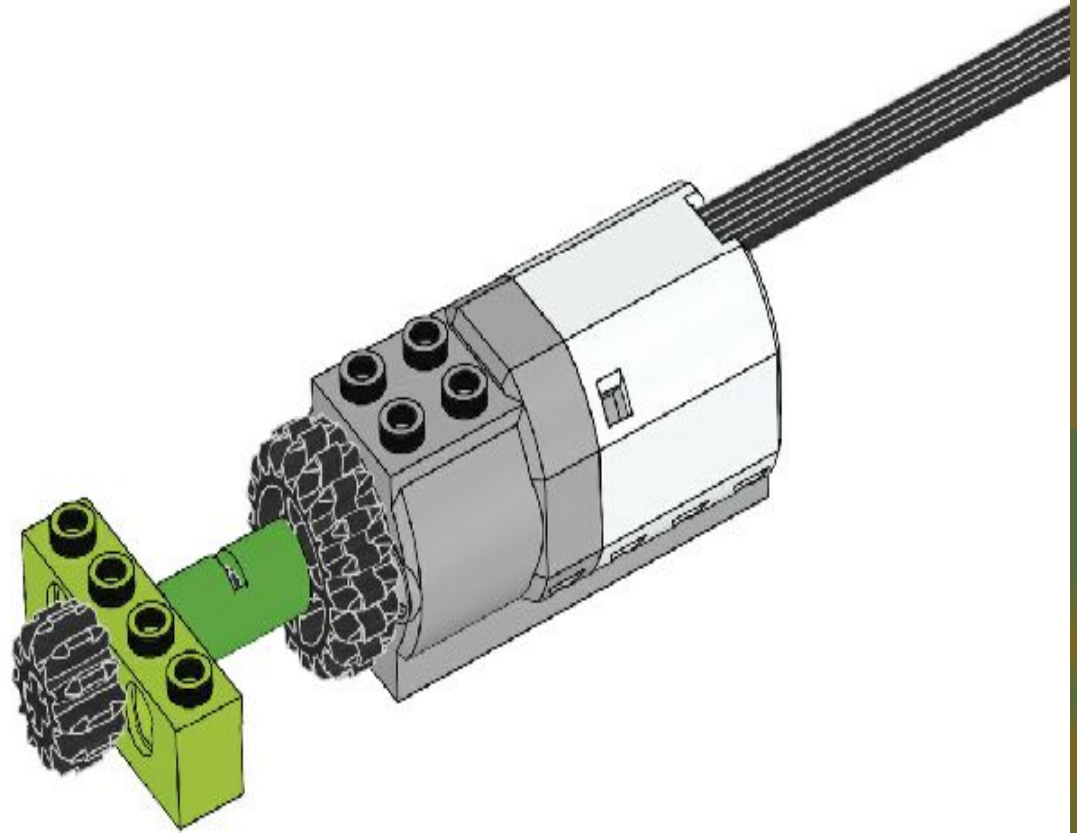

16

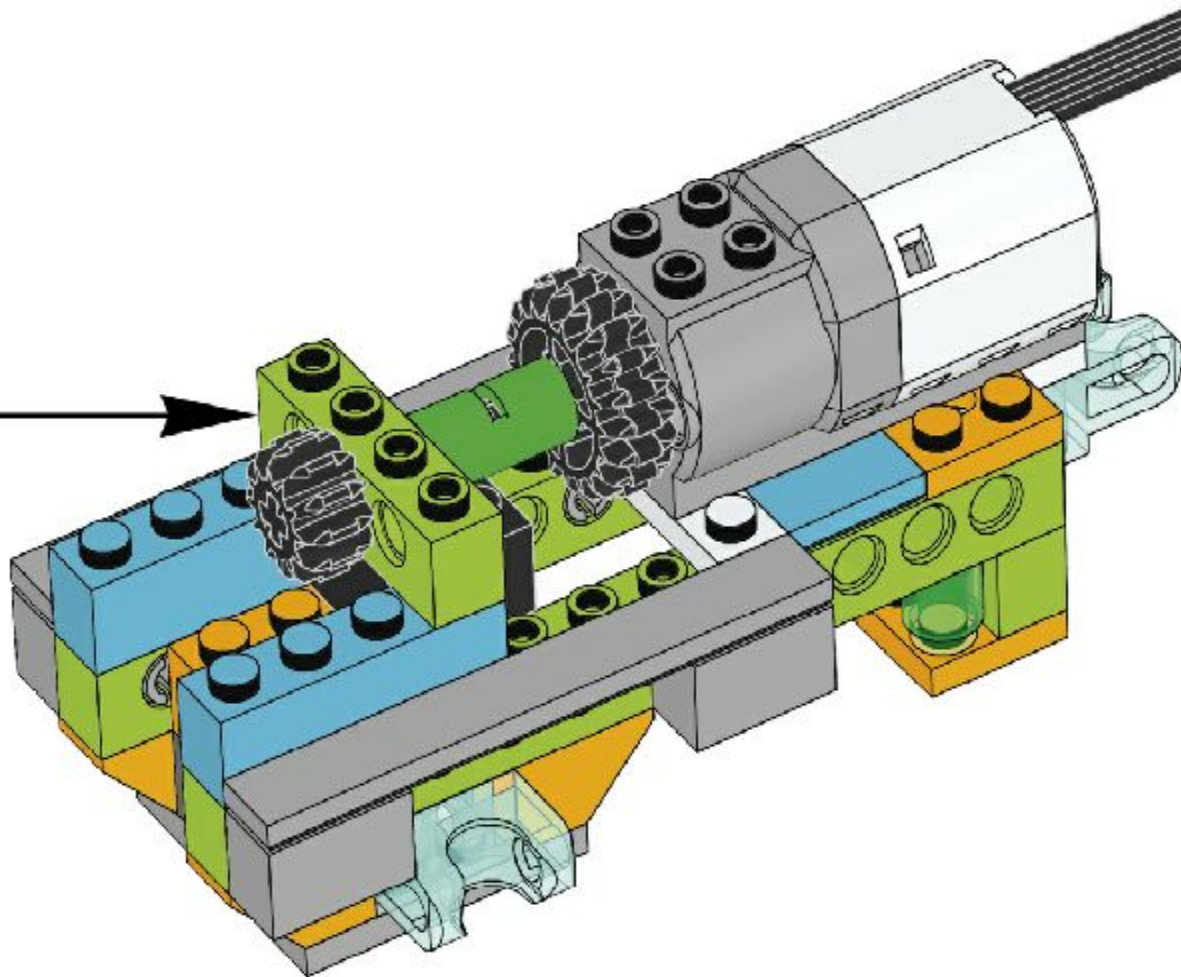



2x

17

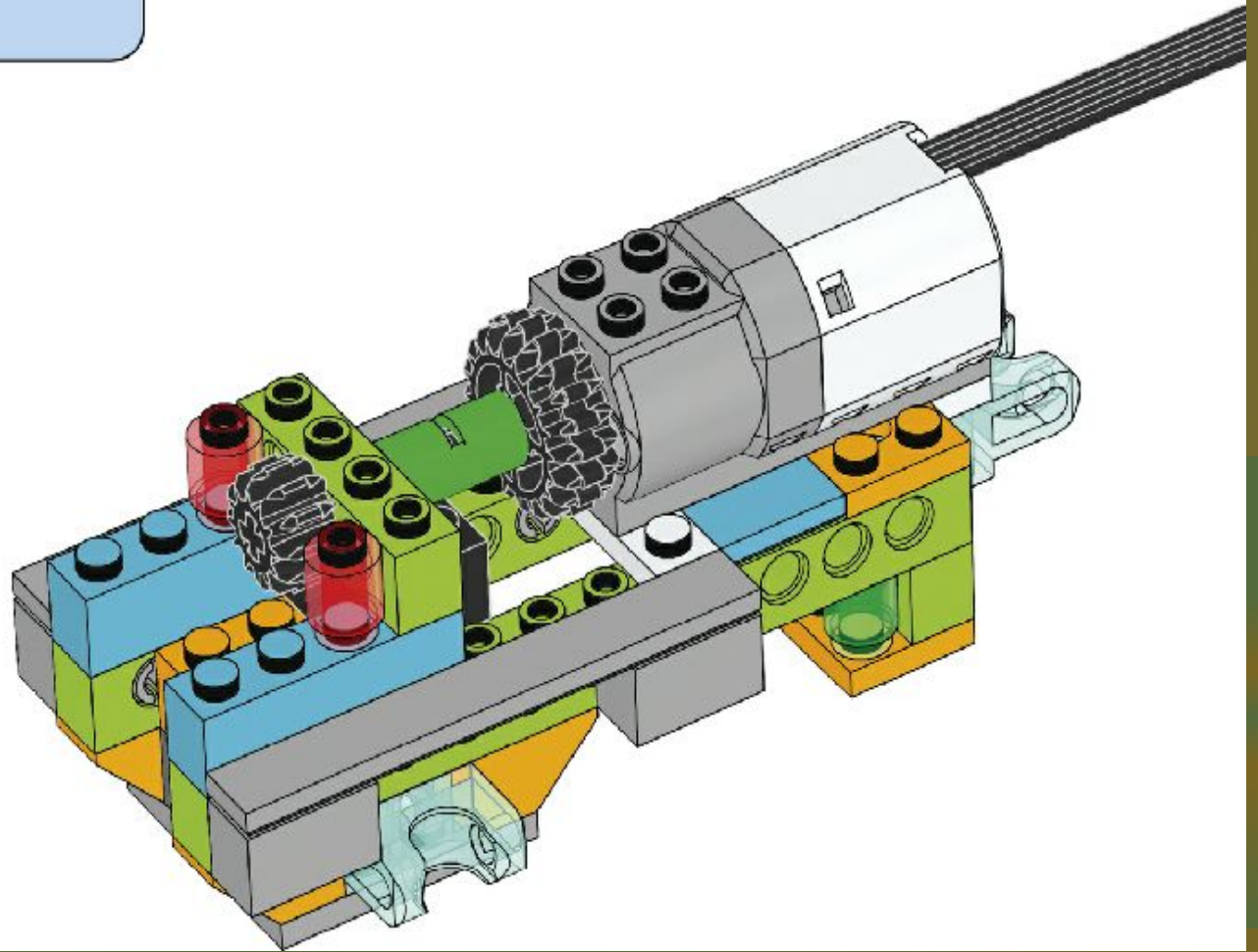



18

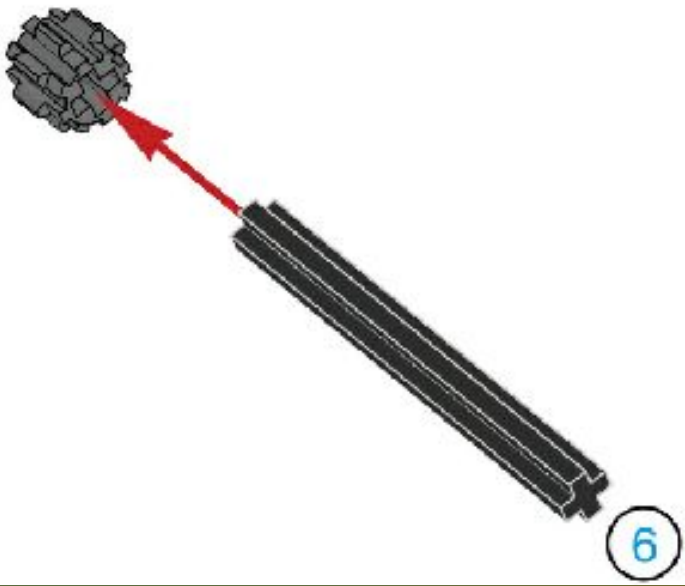



1x

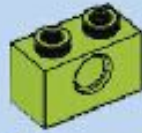

1x

19

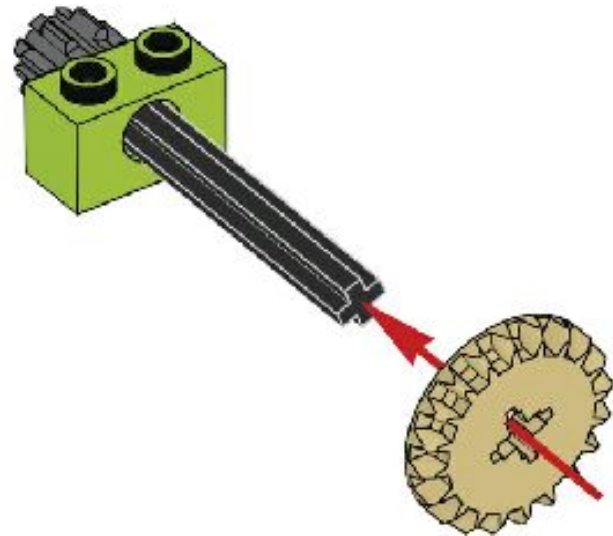



1x



1x

20

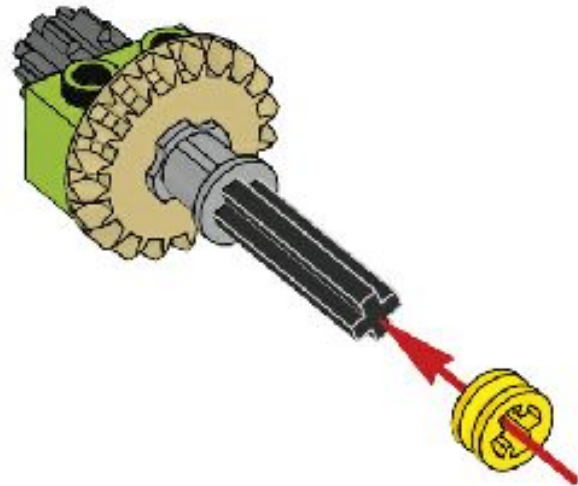



1x



1x

21

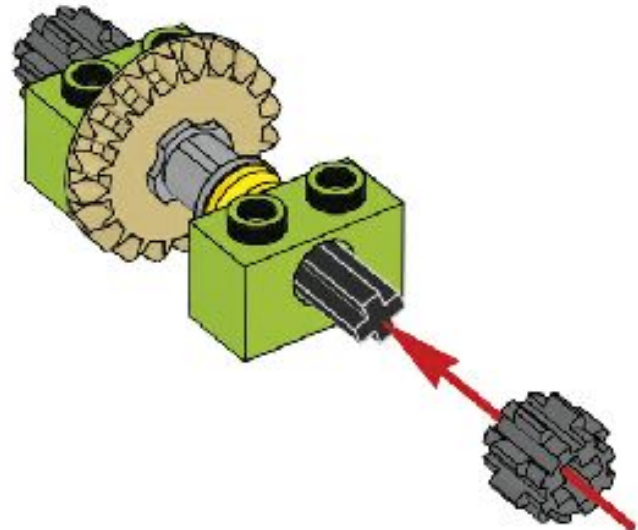

22

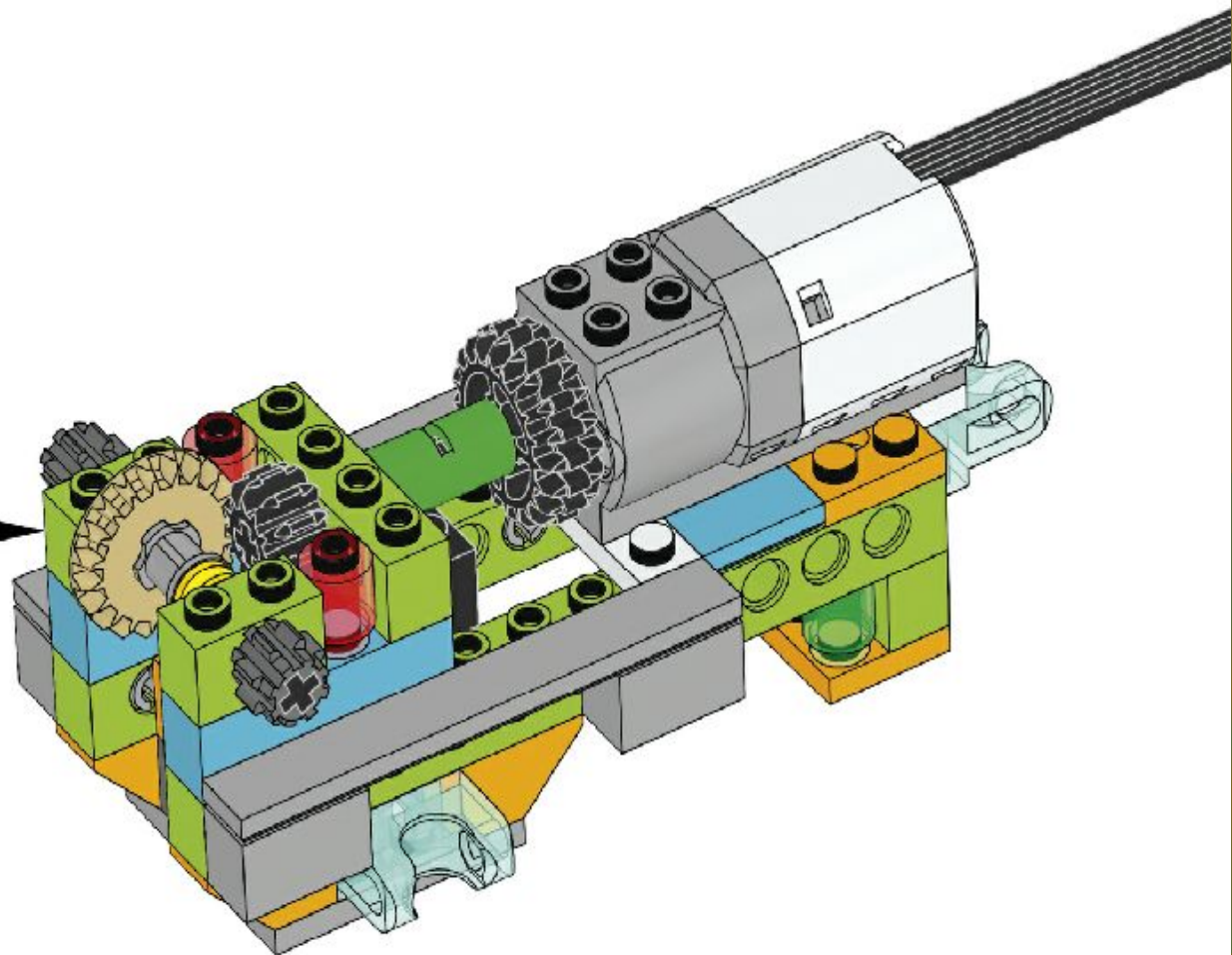

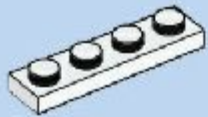

2x

23

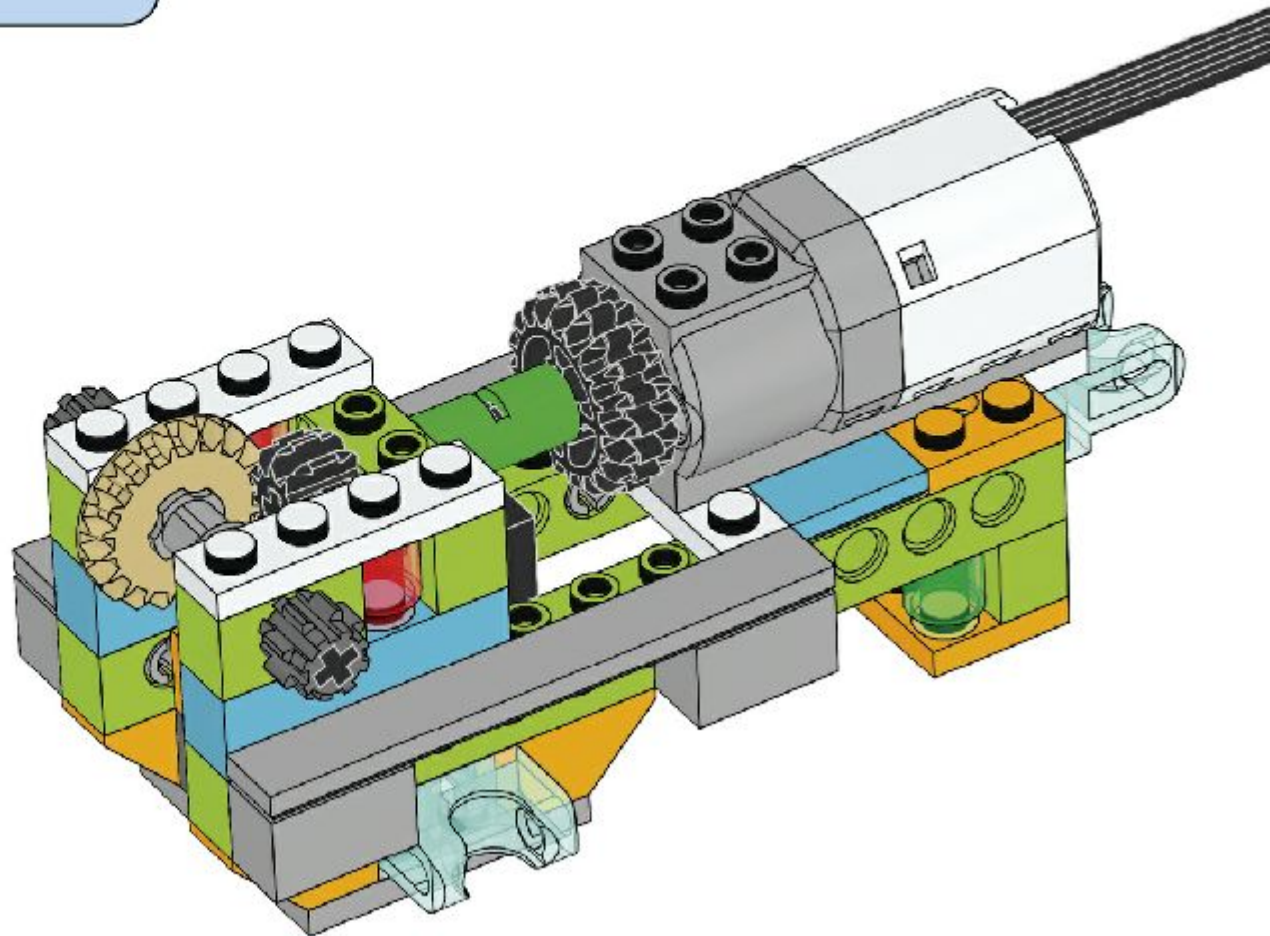

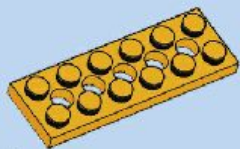

1x

24

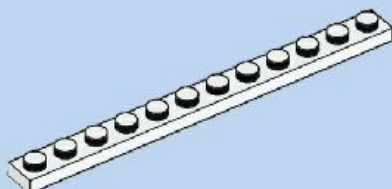
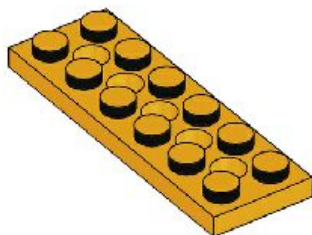

2x



1x

25

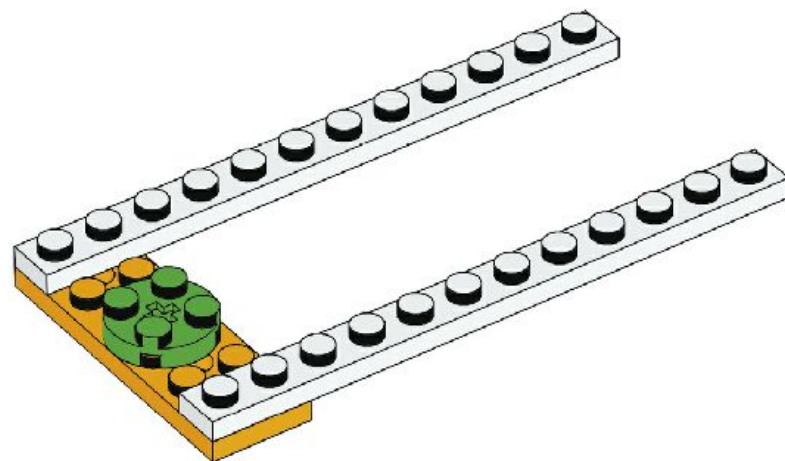

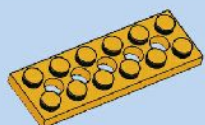

1x

26

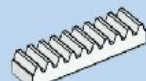
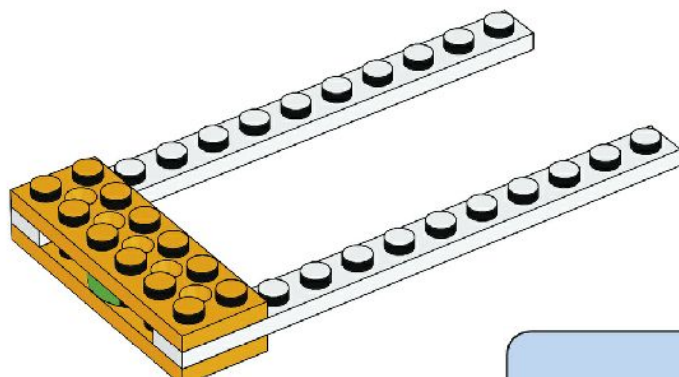

4x

27

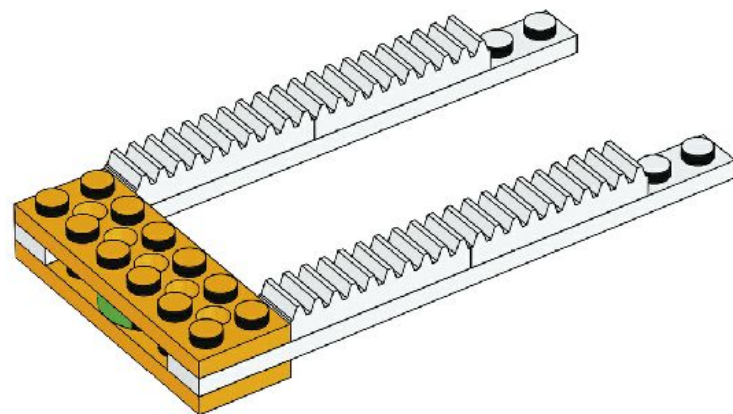

28

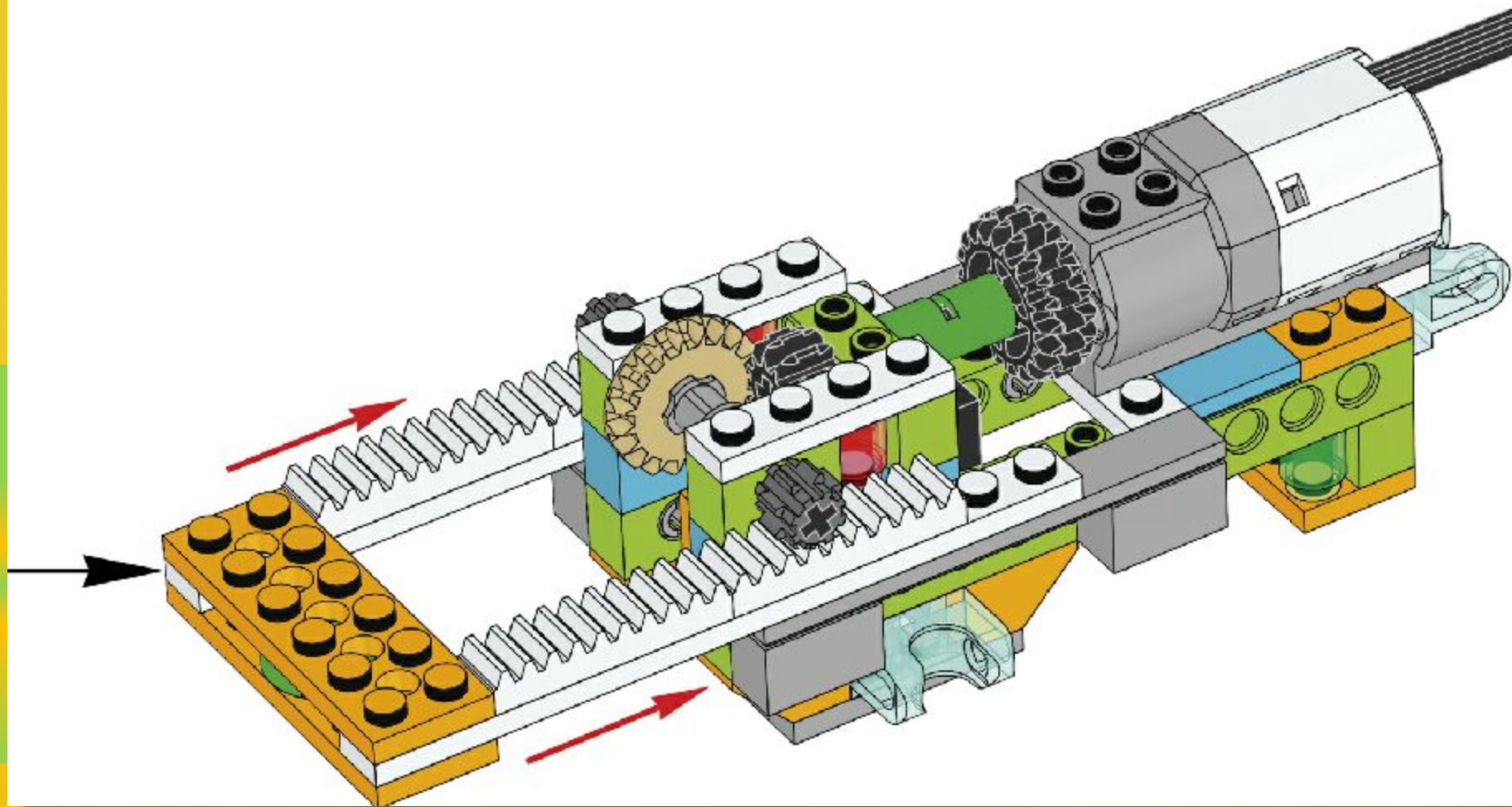



2x

29

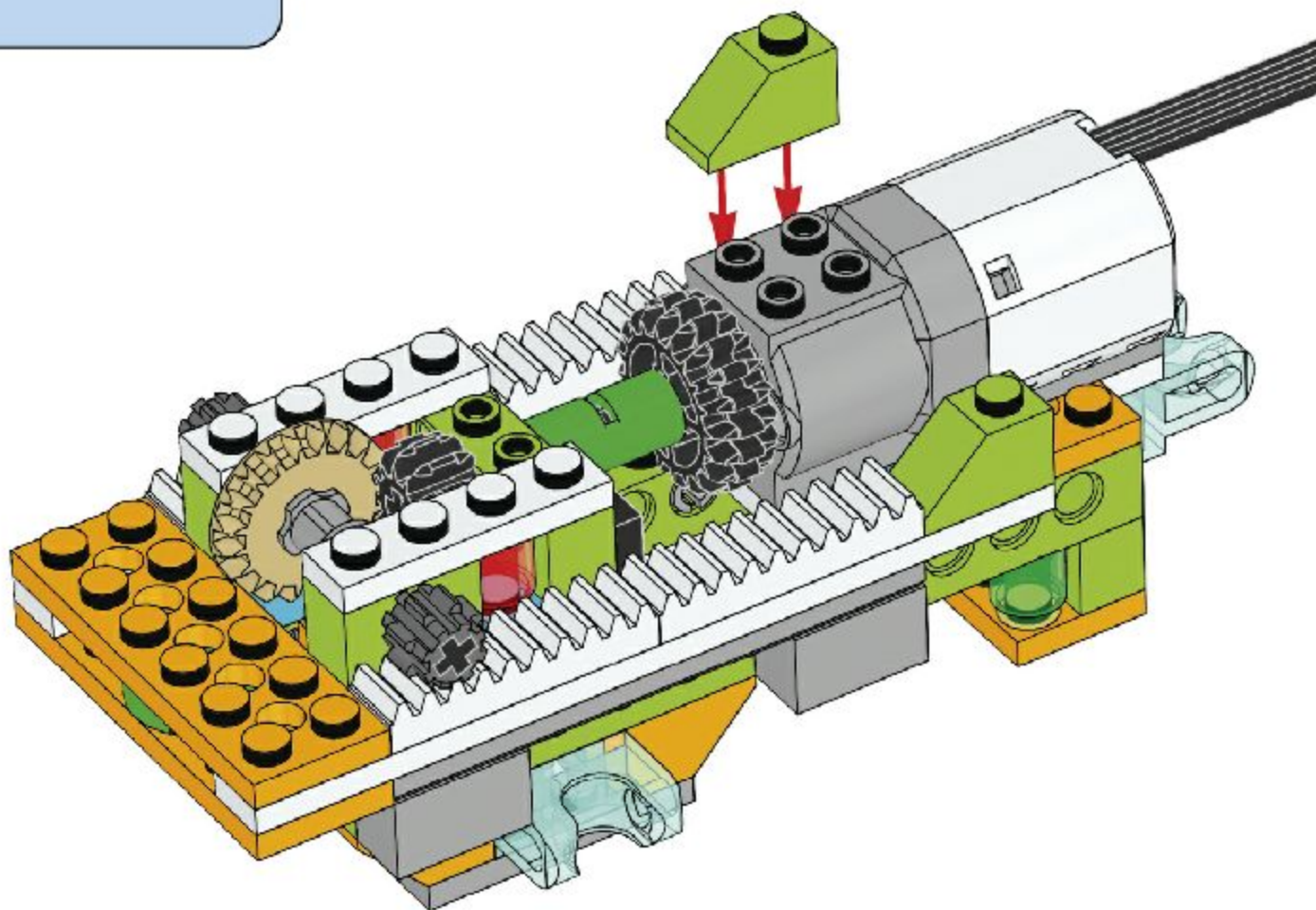

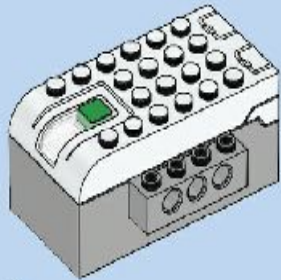

1x

30

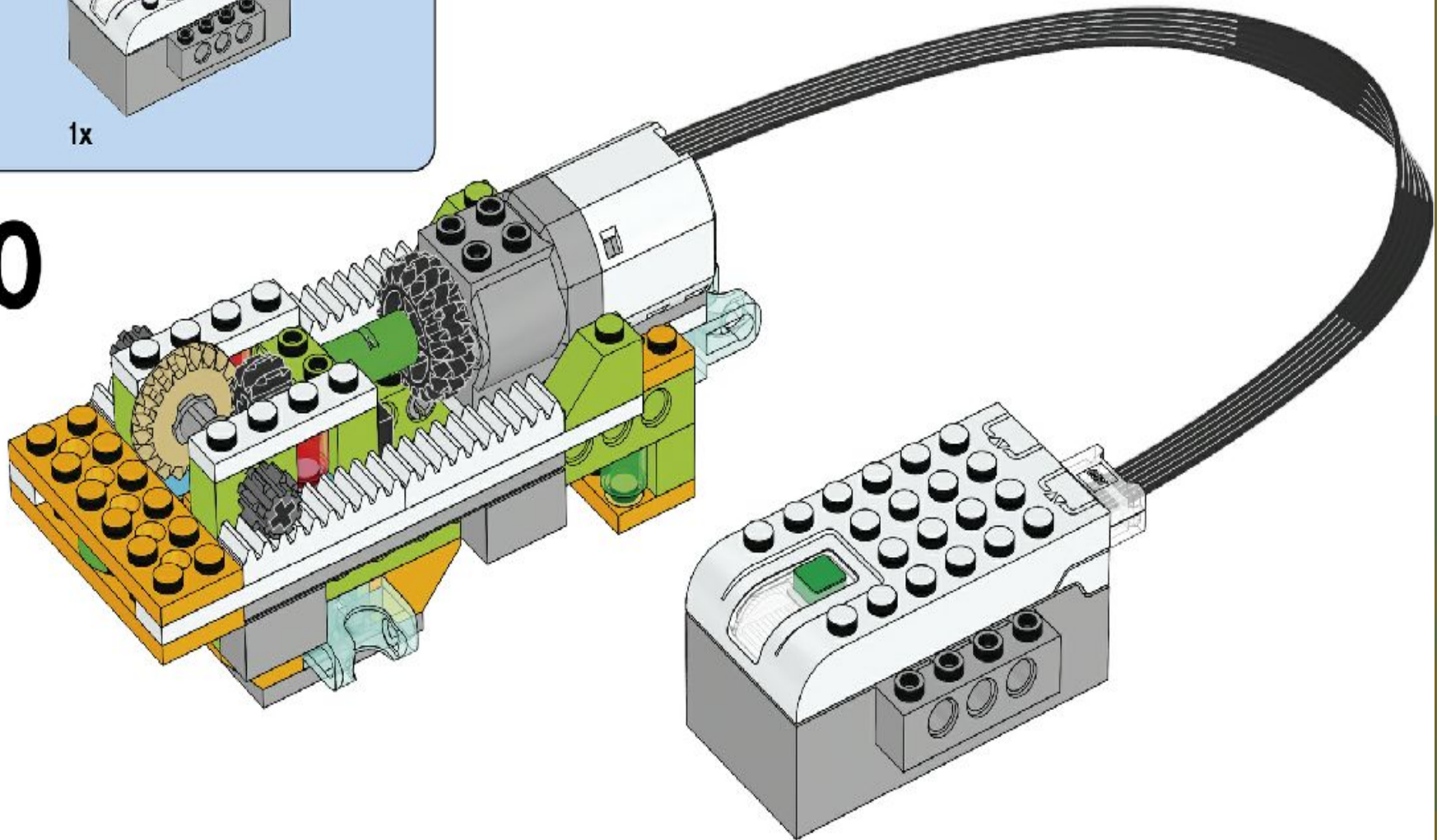



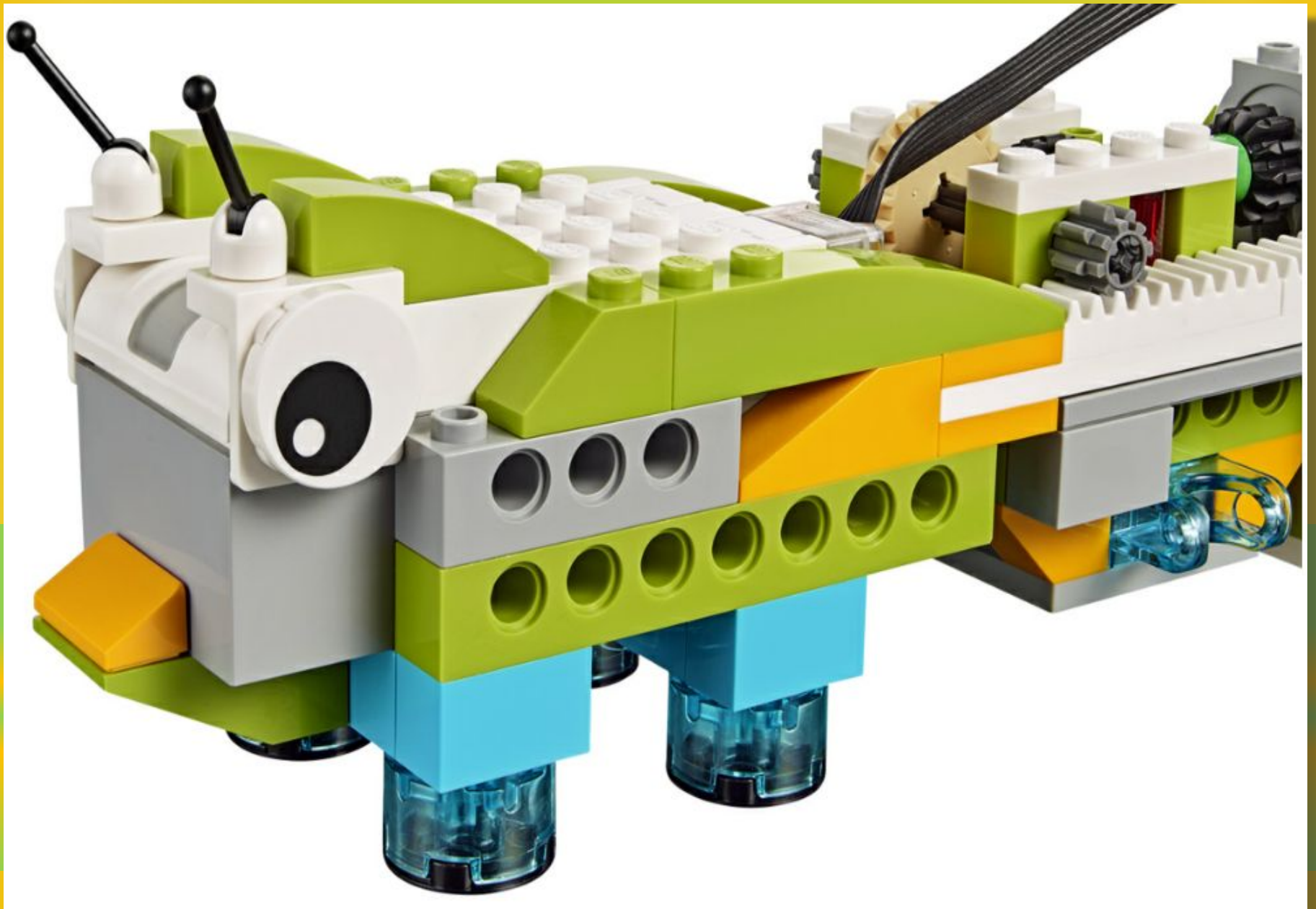



3

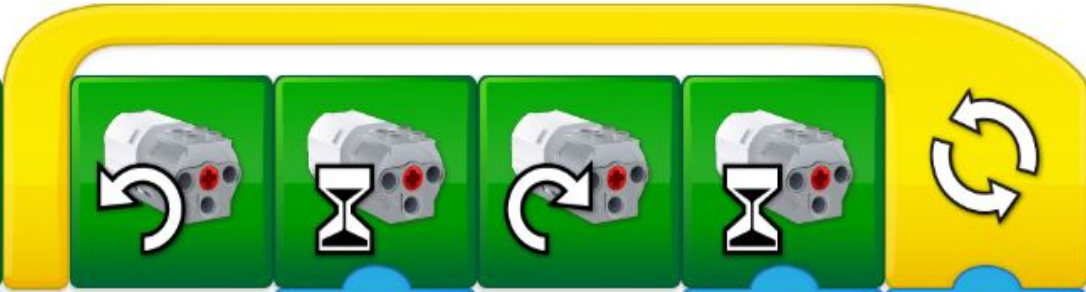

5



1

3

3

3

2

1

До новых
встреч