

Тема: «Растения и опылители»

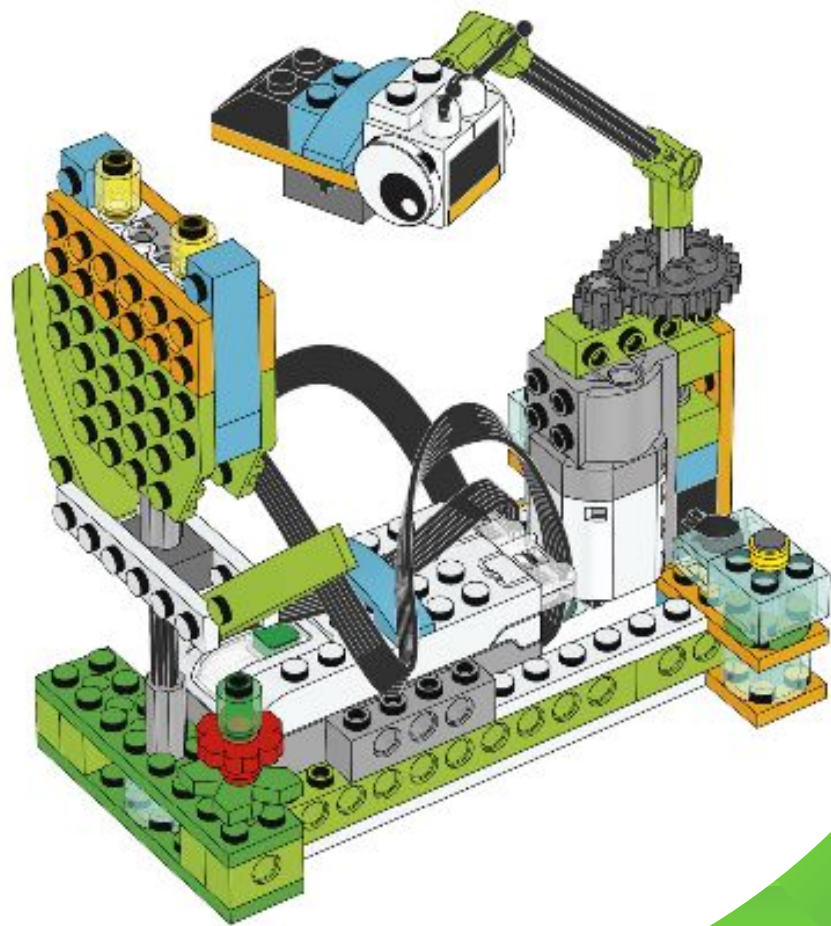

(практическое занятие)

*Используя детали конструктора
«LEGO=WeDo 2.0 построим
модель пчелы летающей вокруг
цветка, заполненного пыльцой,
согласно инструкции,
размещенной ниже.*



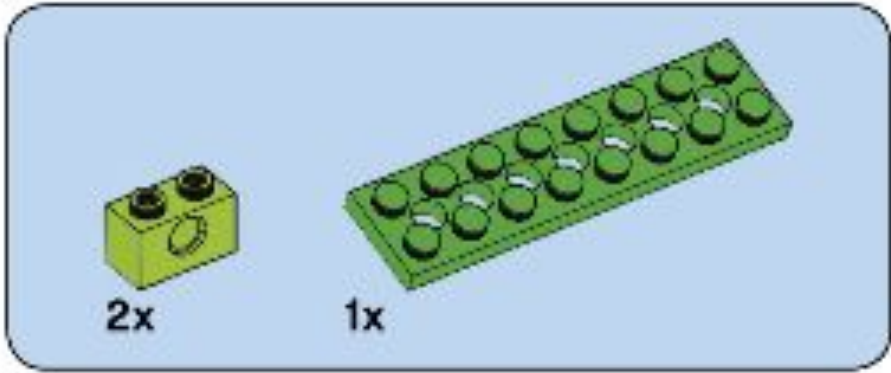

1

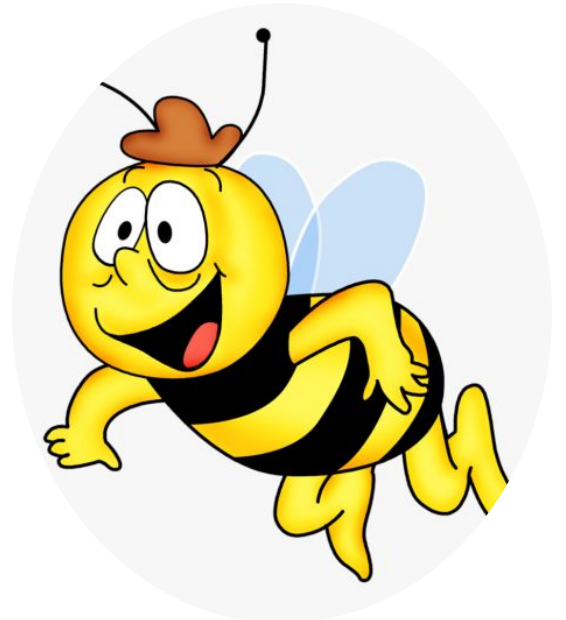
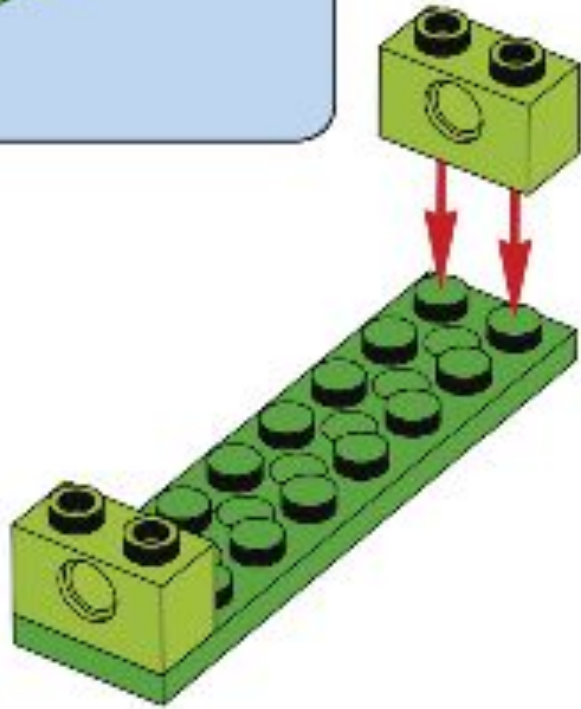

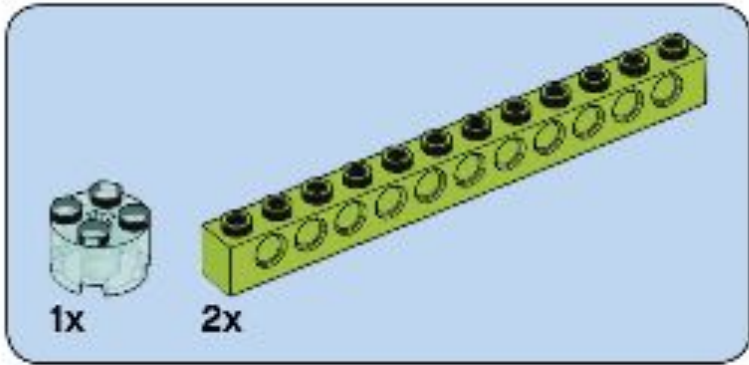

2

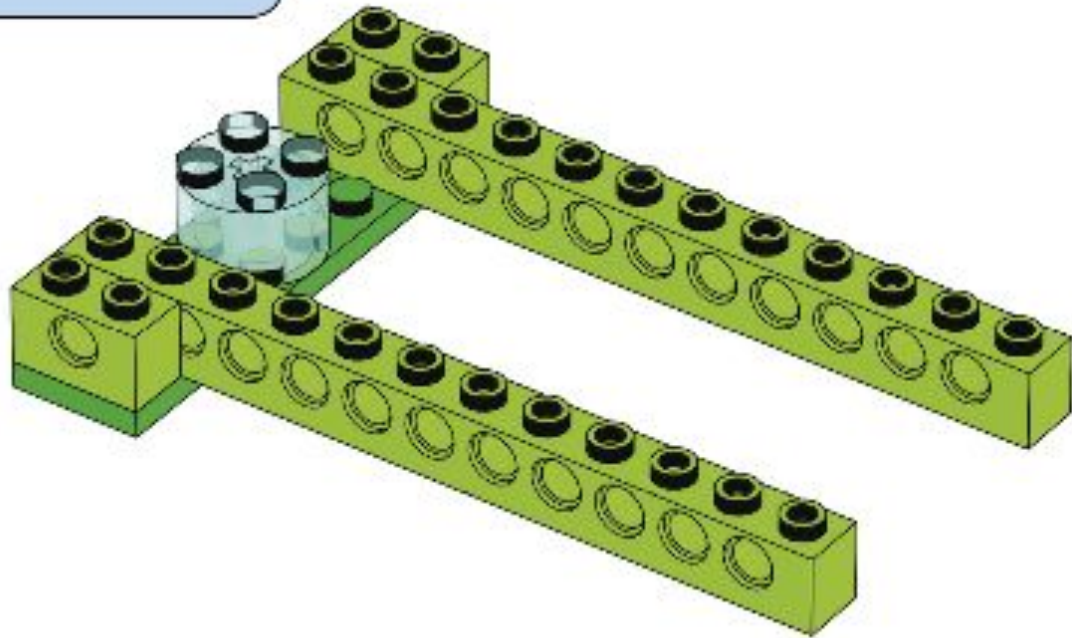

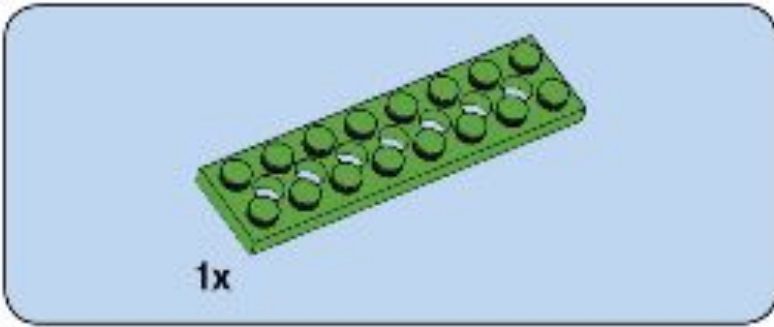

3

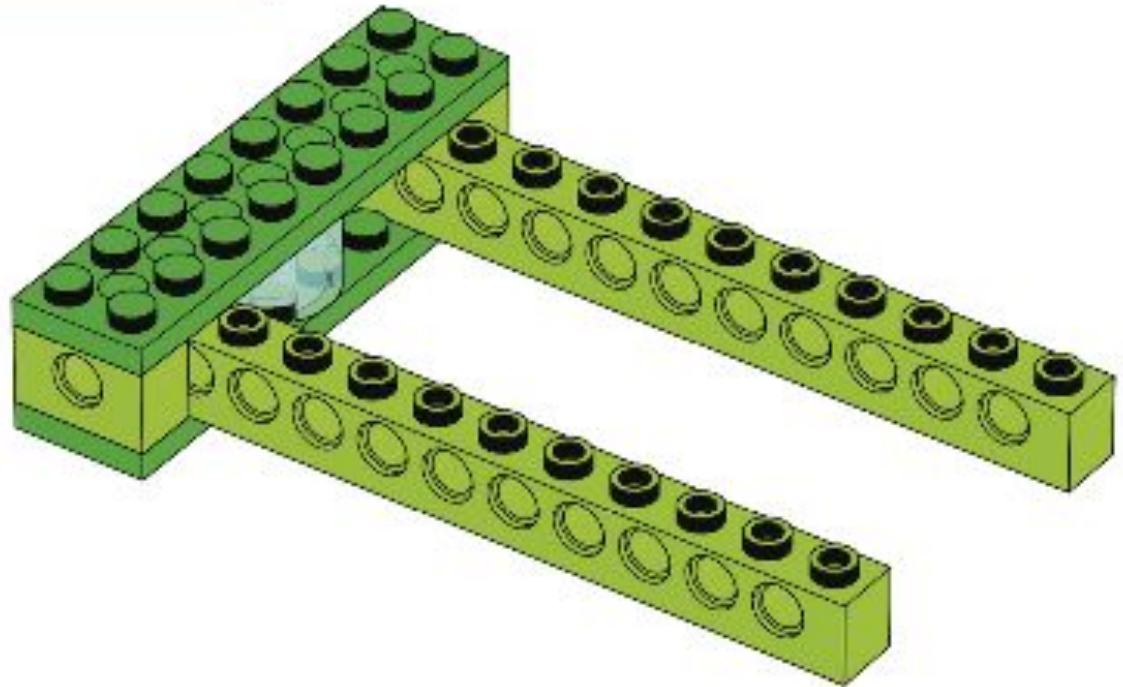

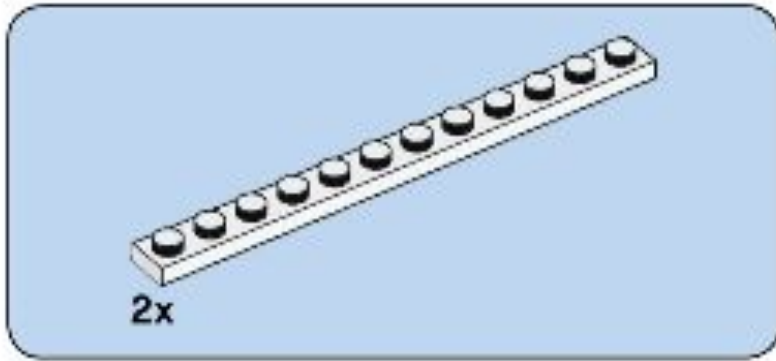

4

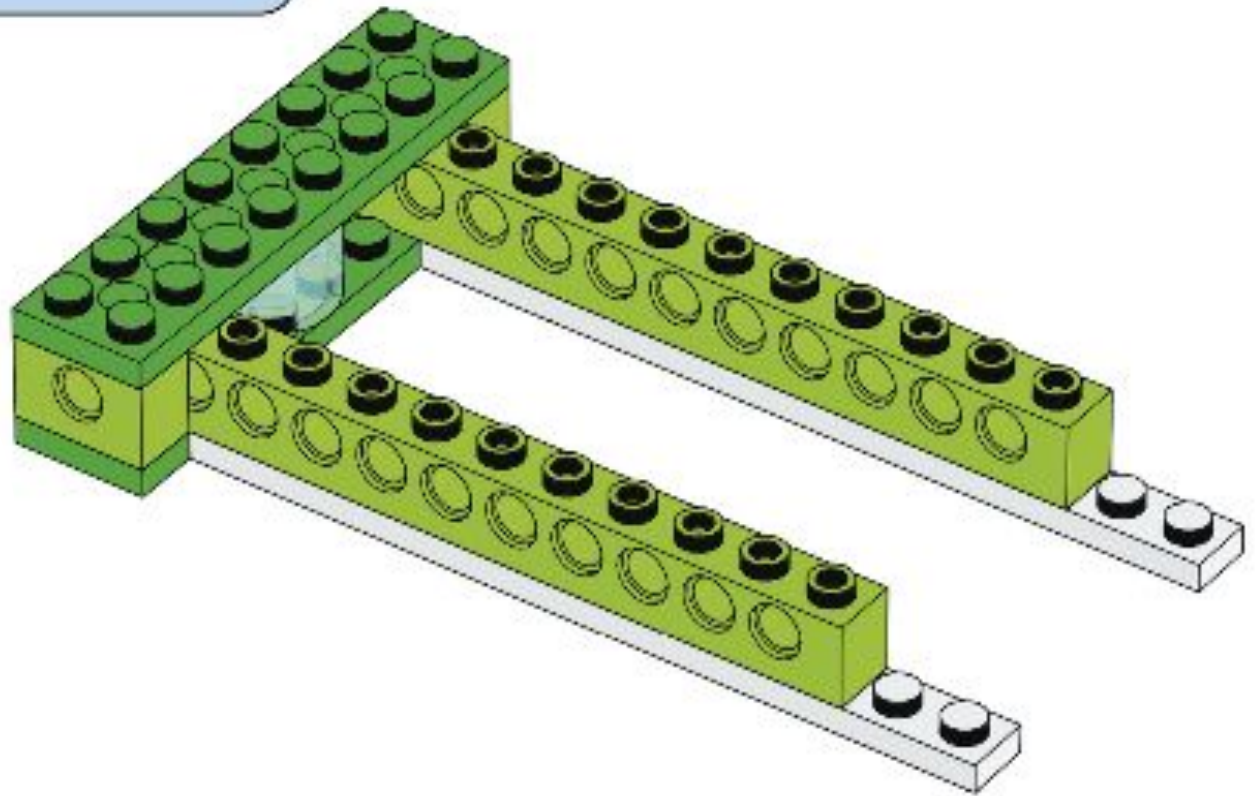

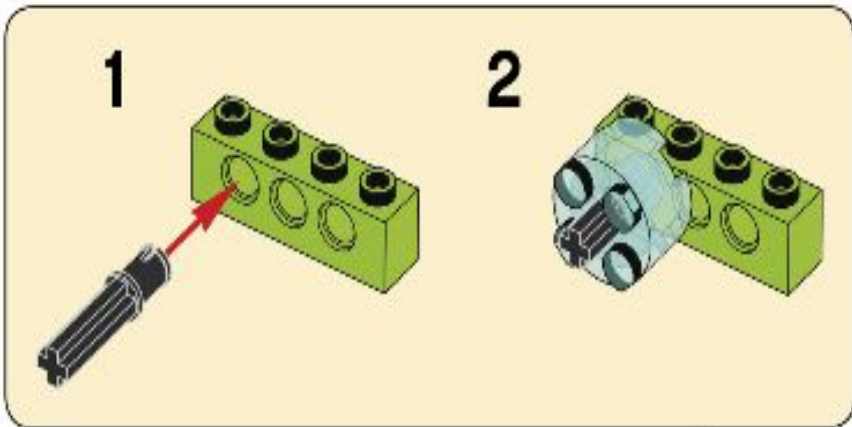
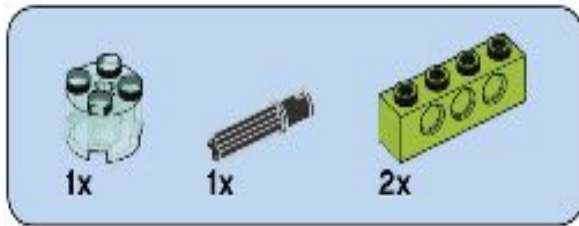

5

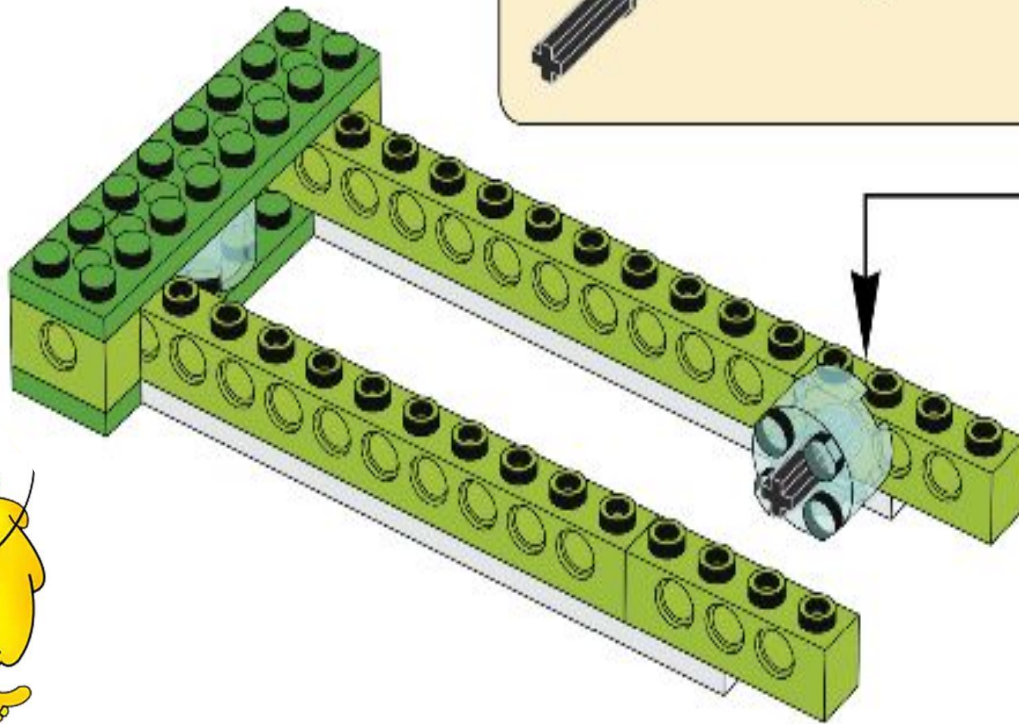

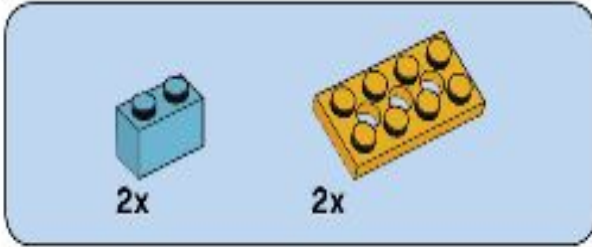

6

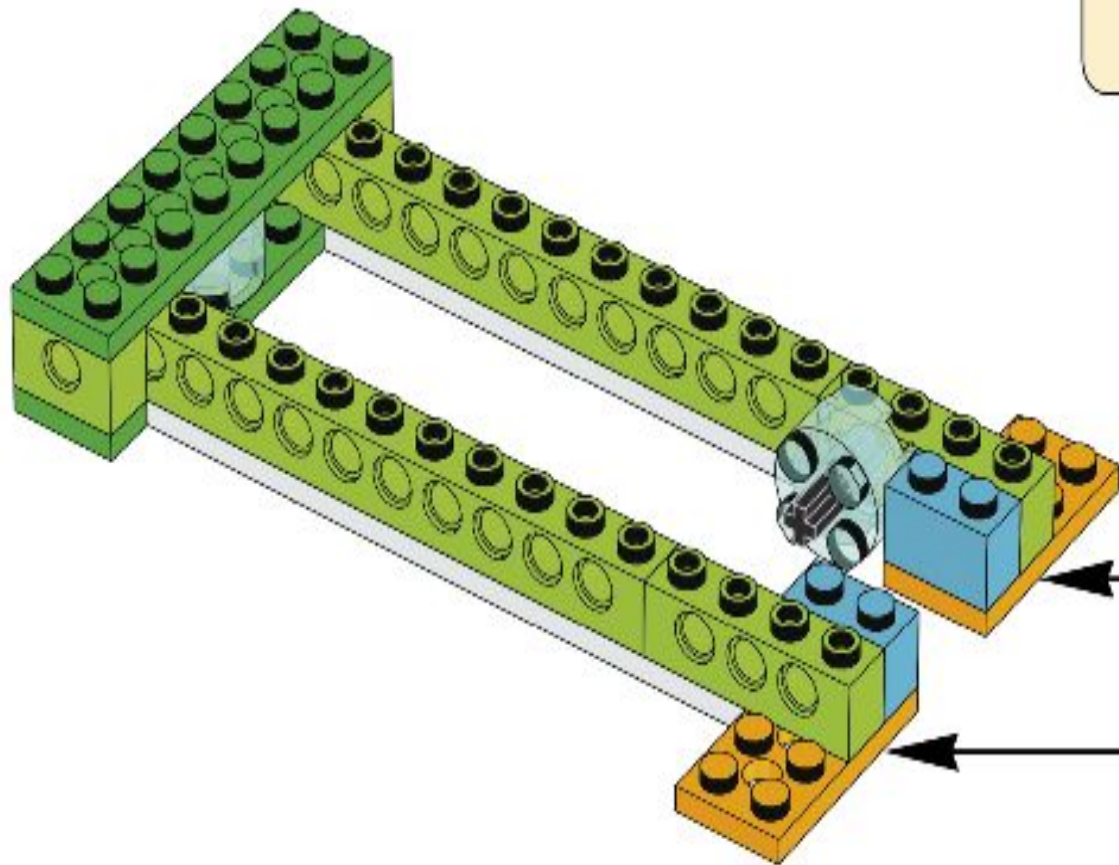
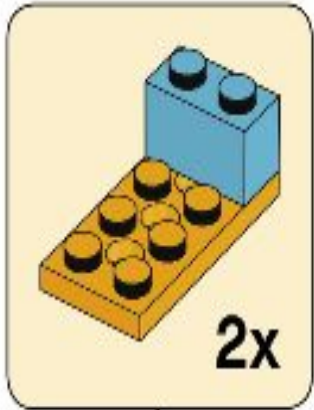



2x

7

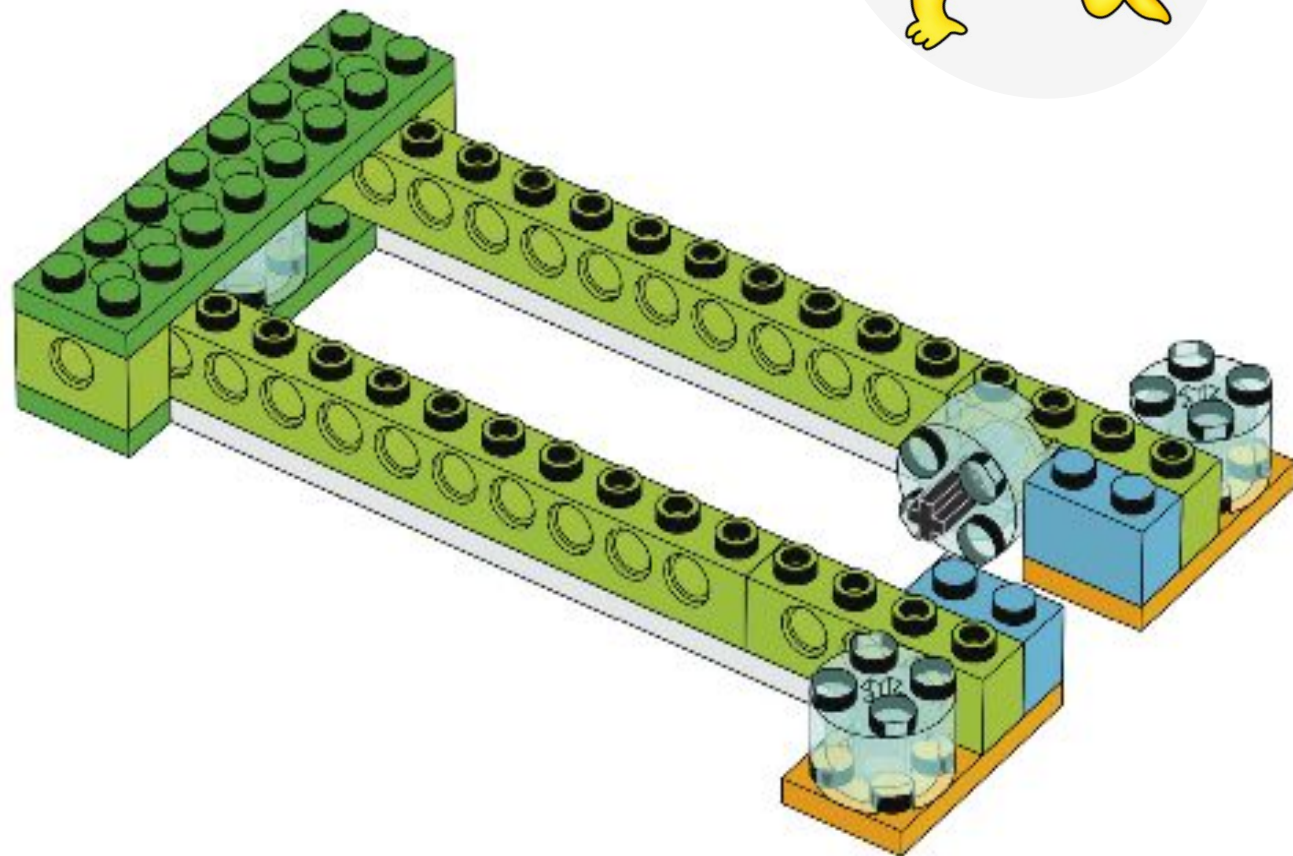

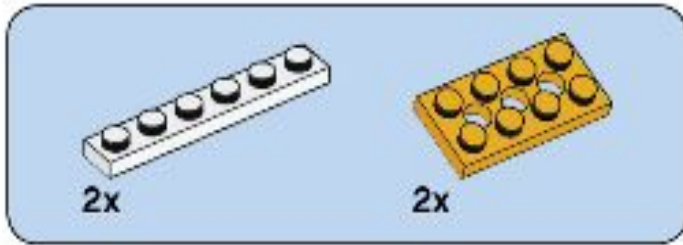

8

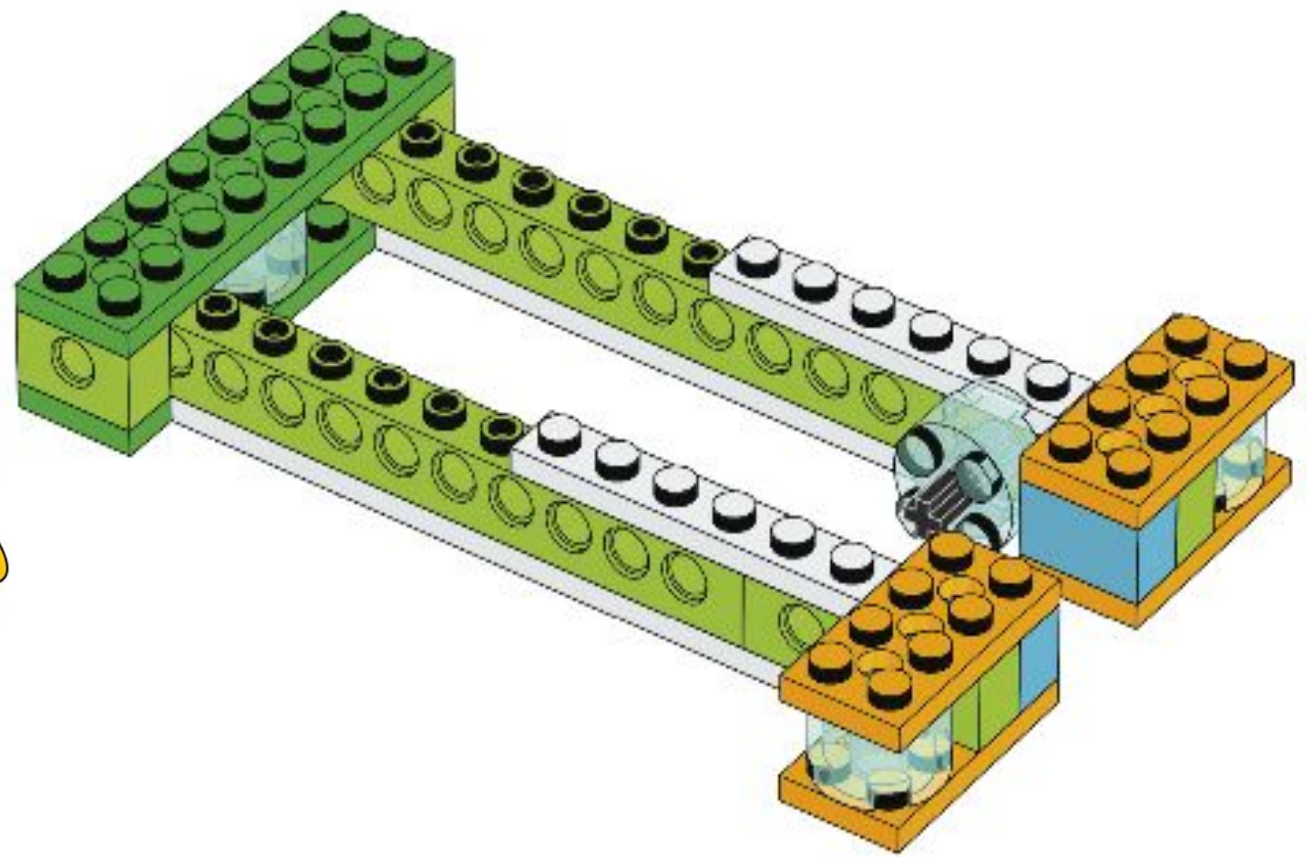



2x



2x

9

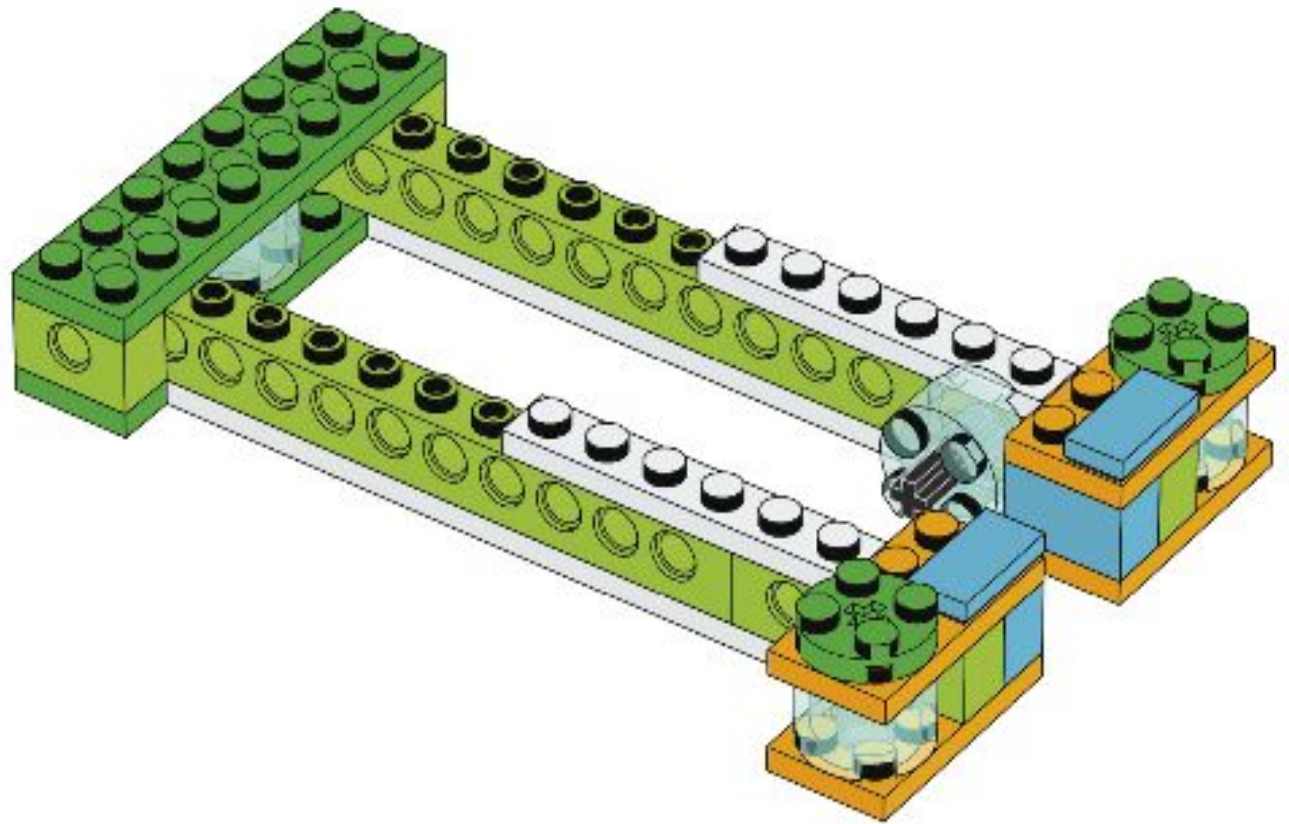

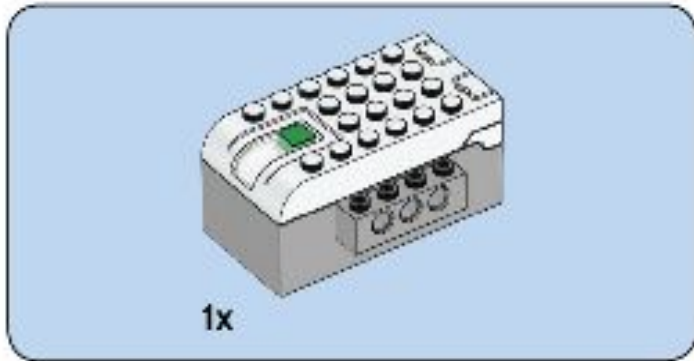

10

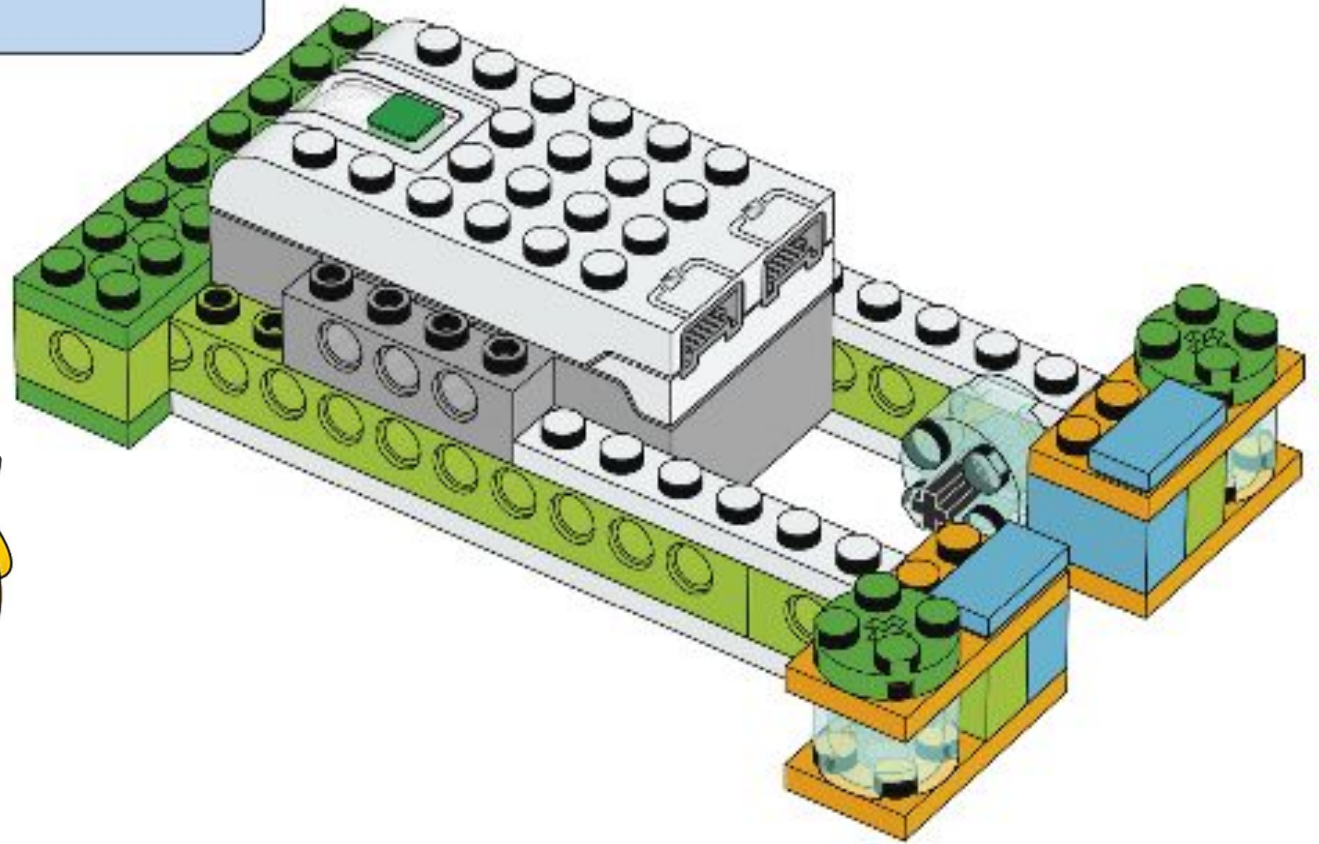

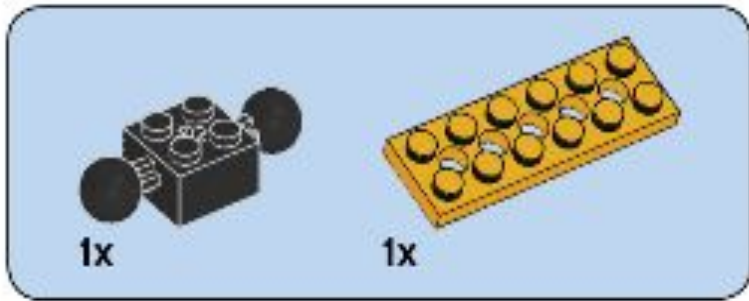

11

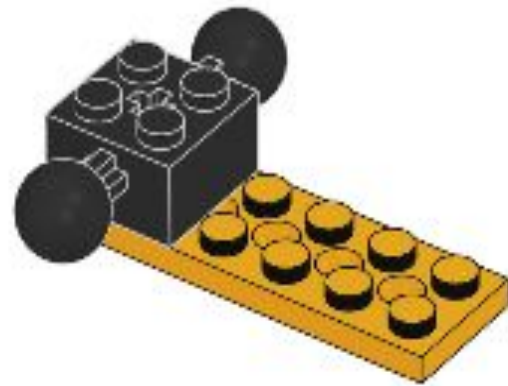
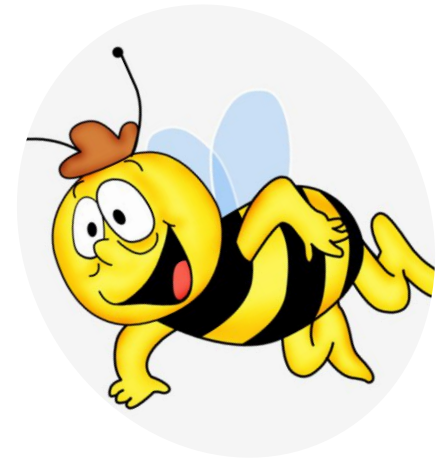

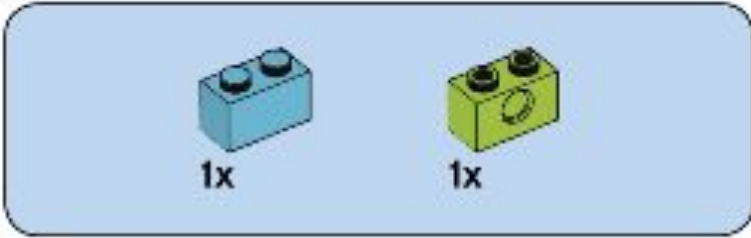

12

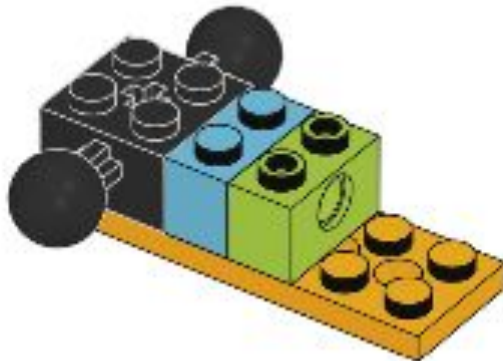
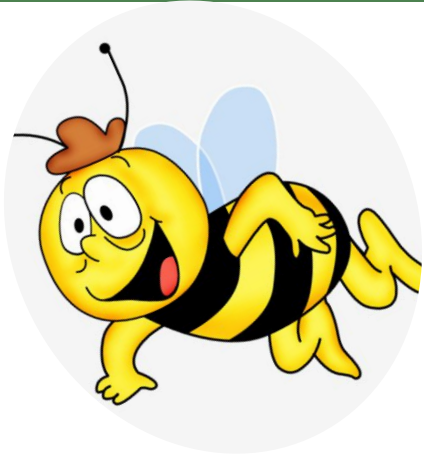

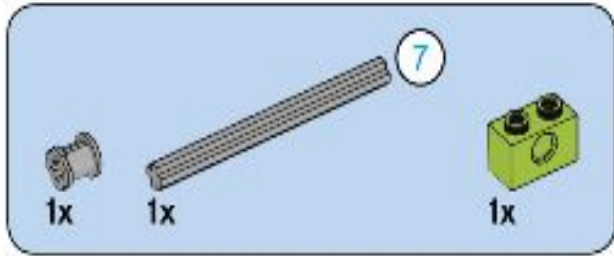

13

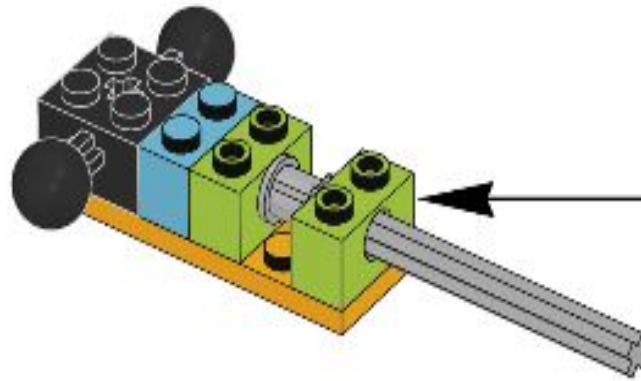
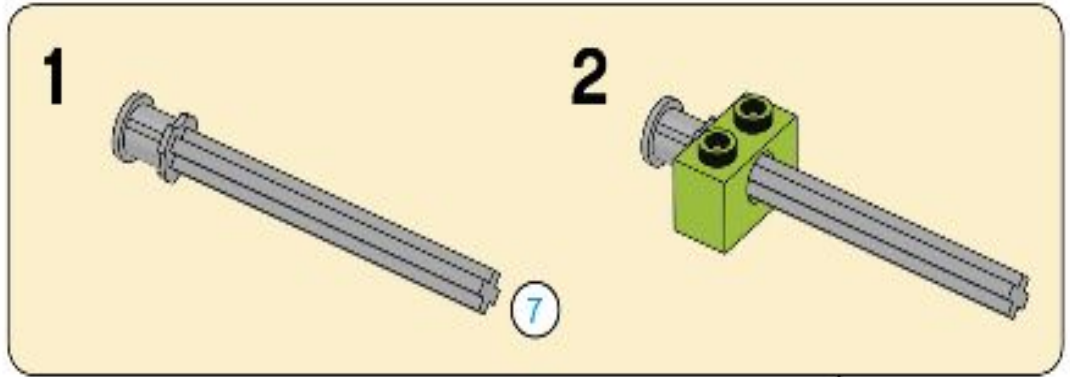

14

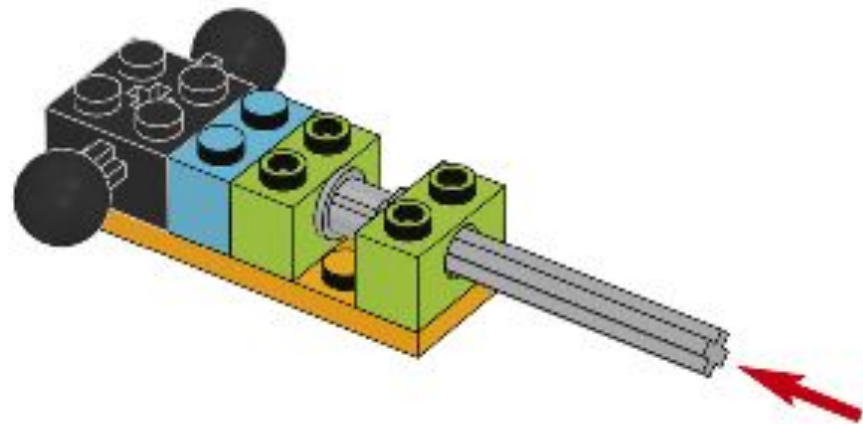

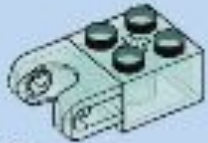

2x

15

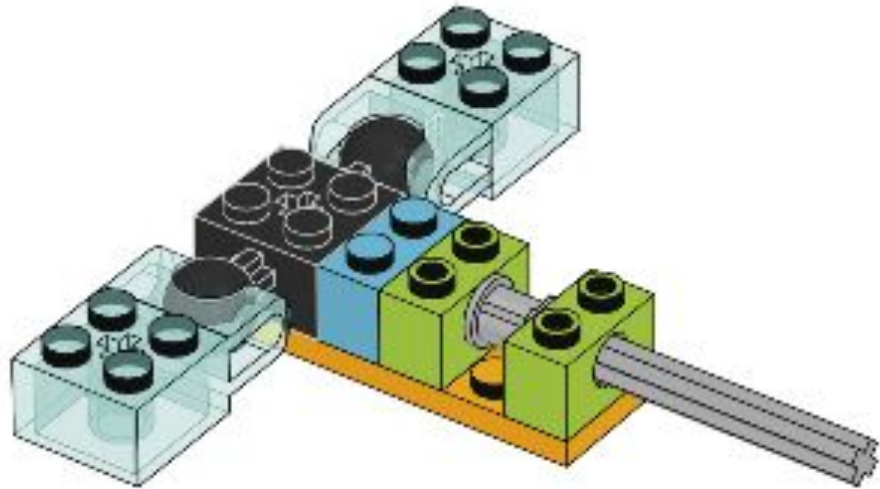

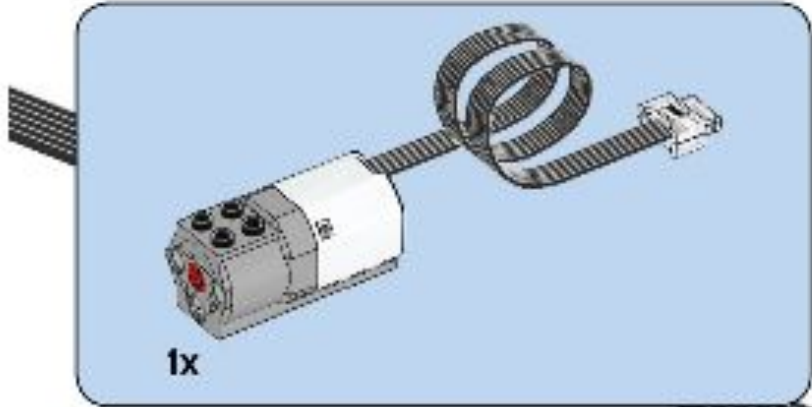

16

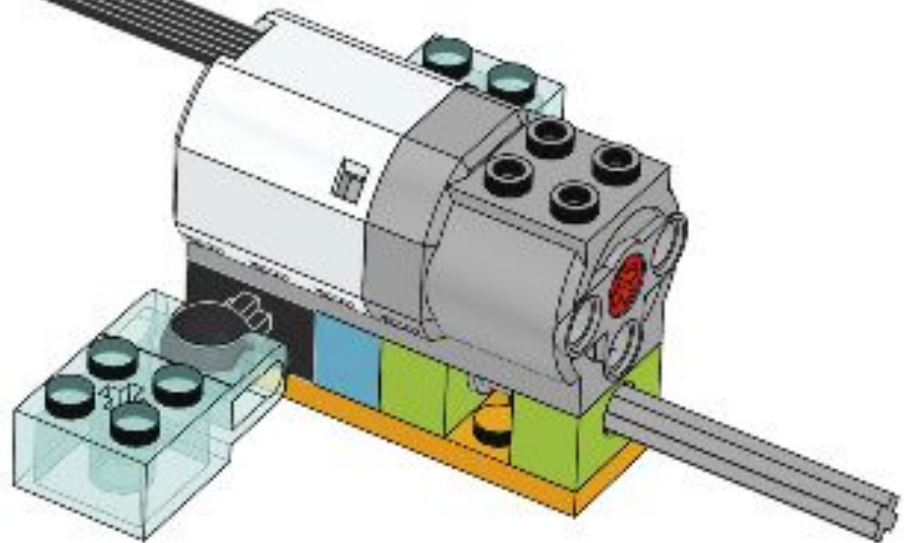

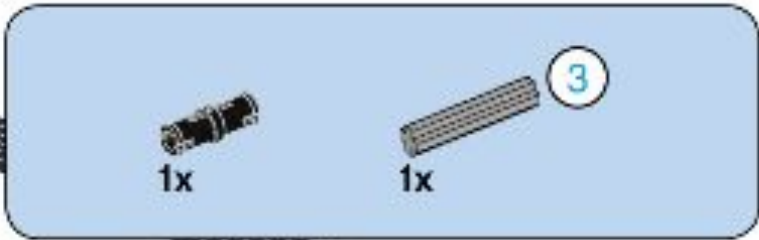

17

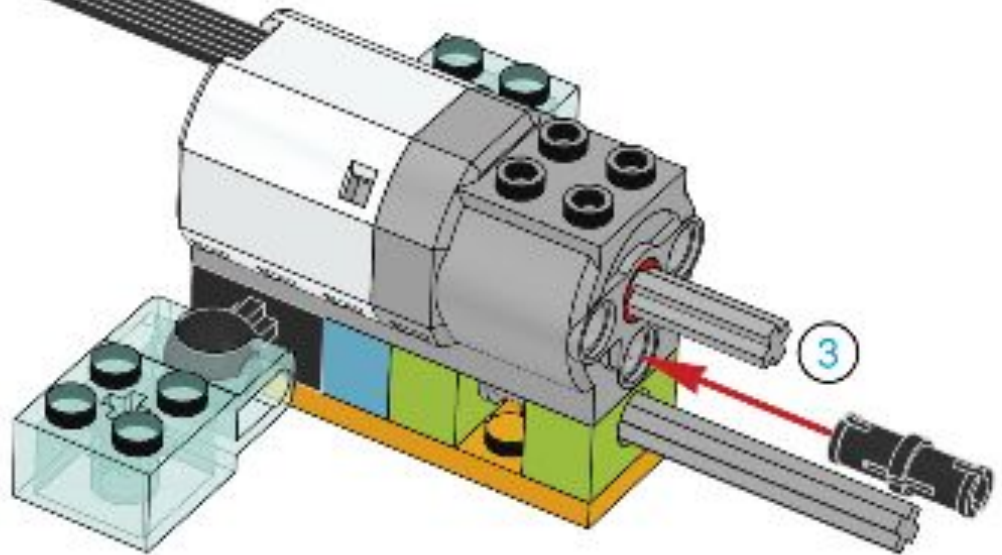
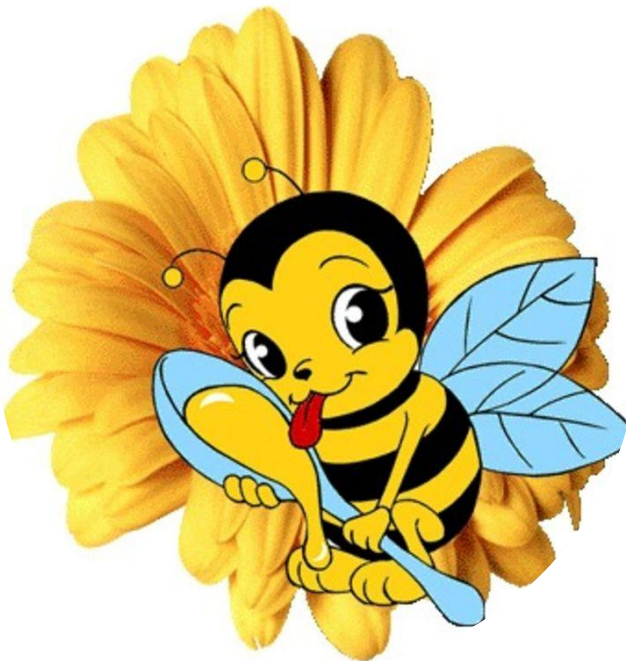

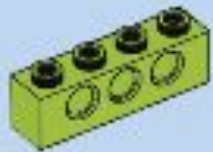

1x

18

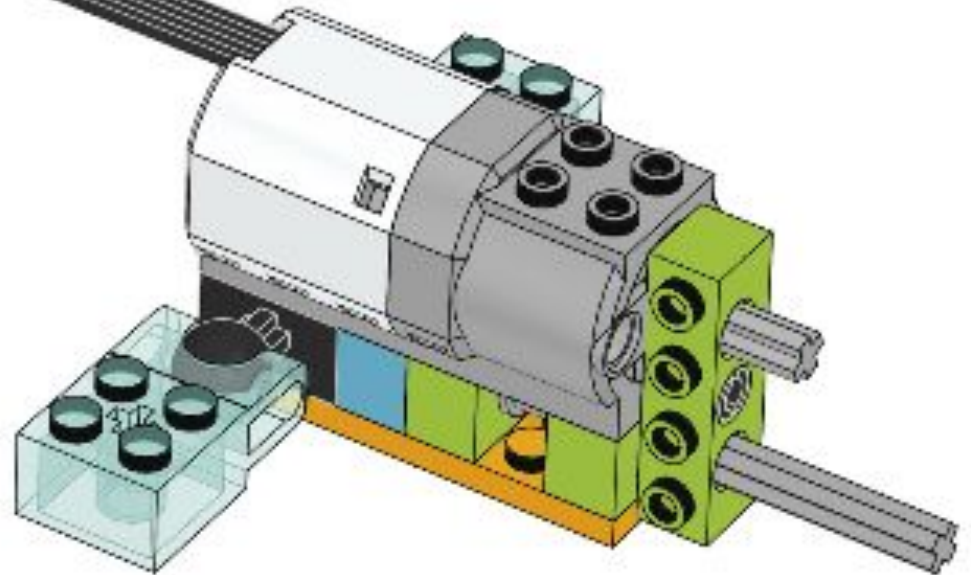

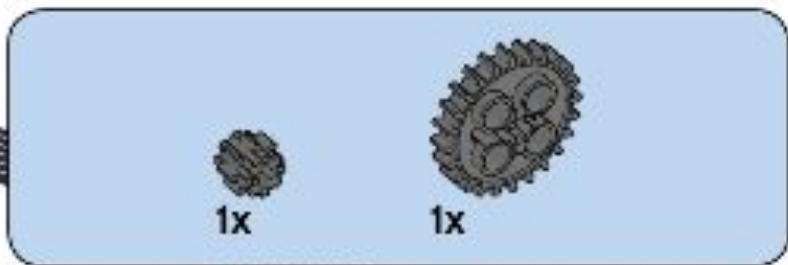

19

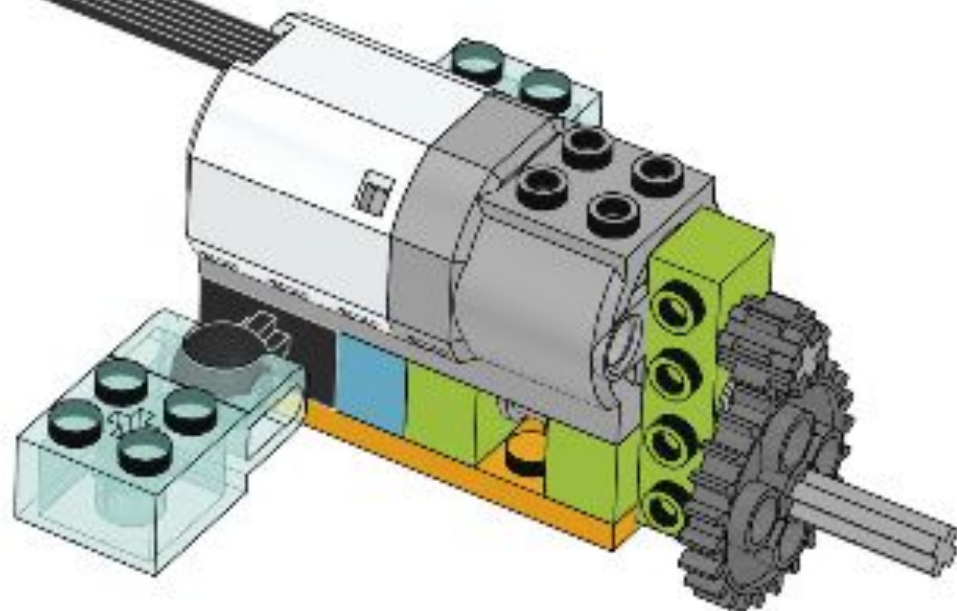

20

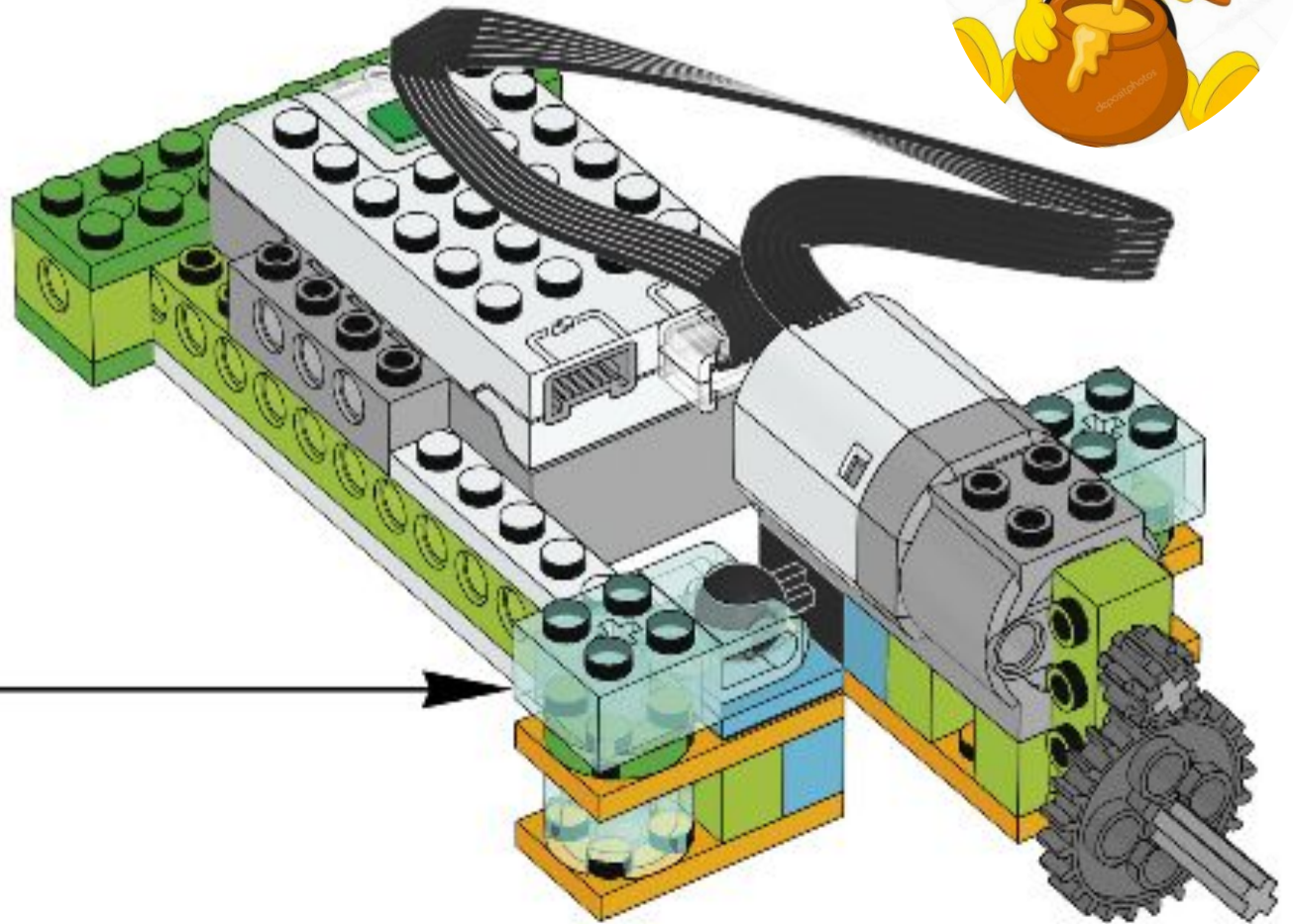

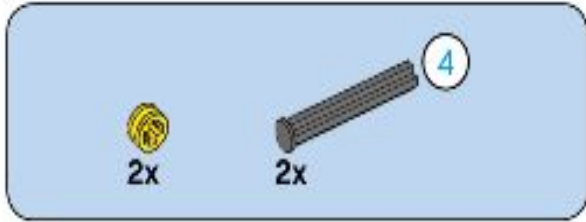

21

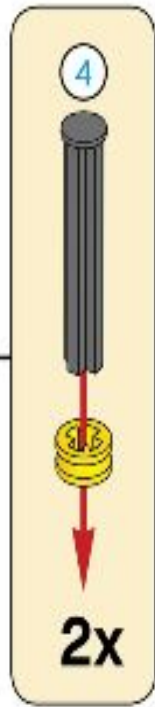
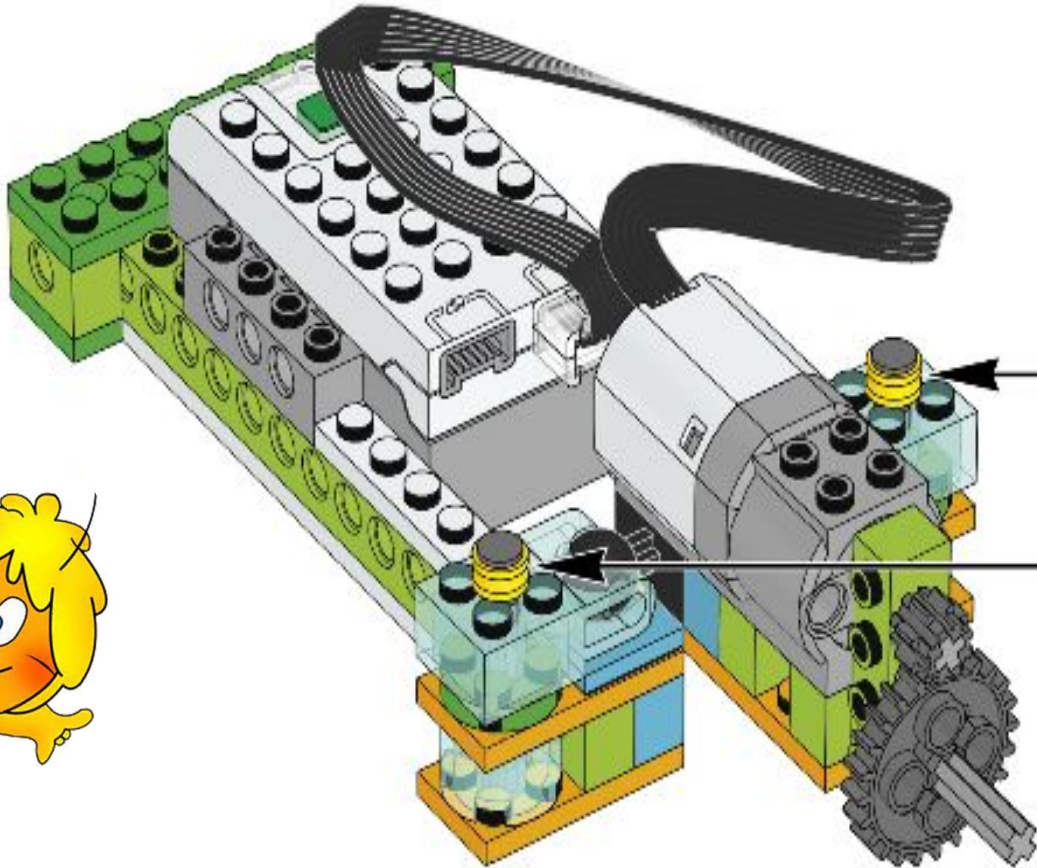

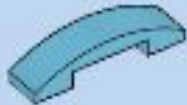

1x

22

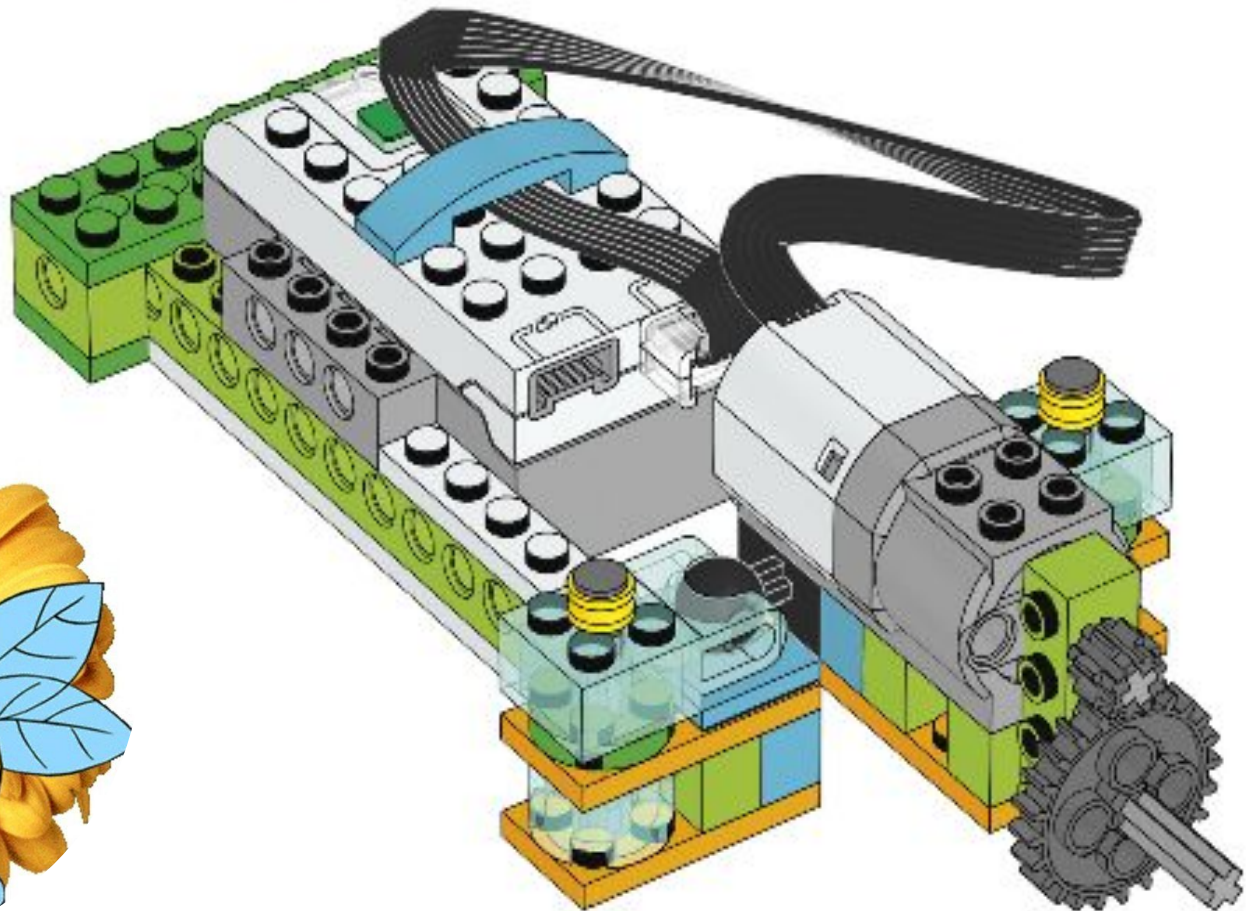

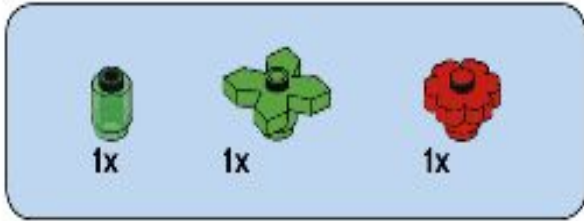

23

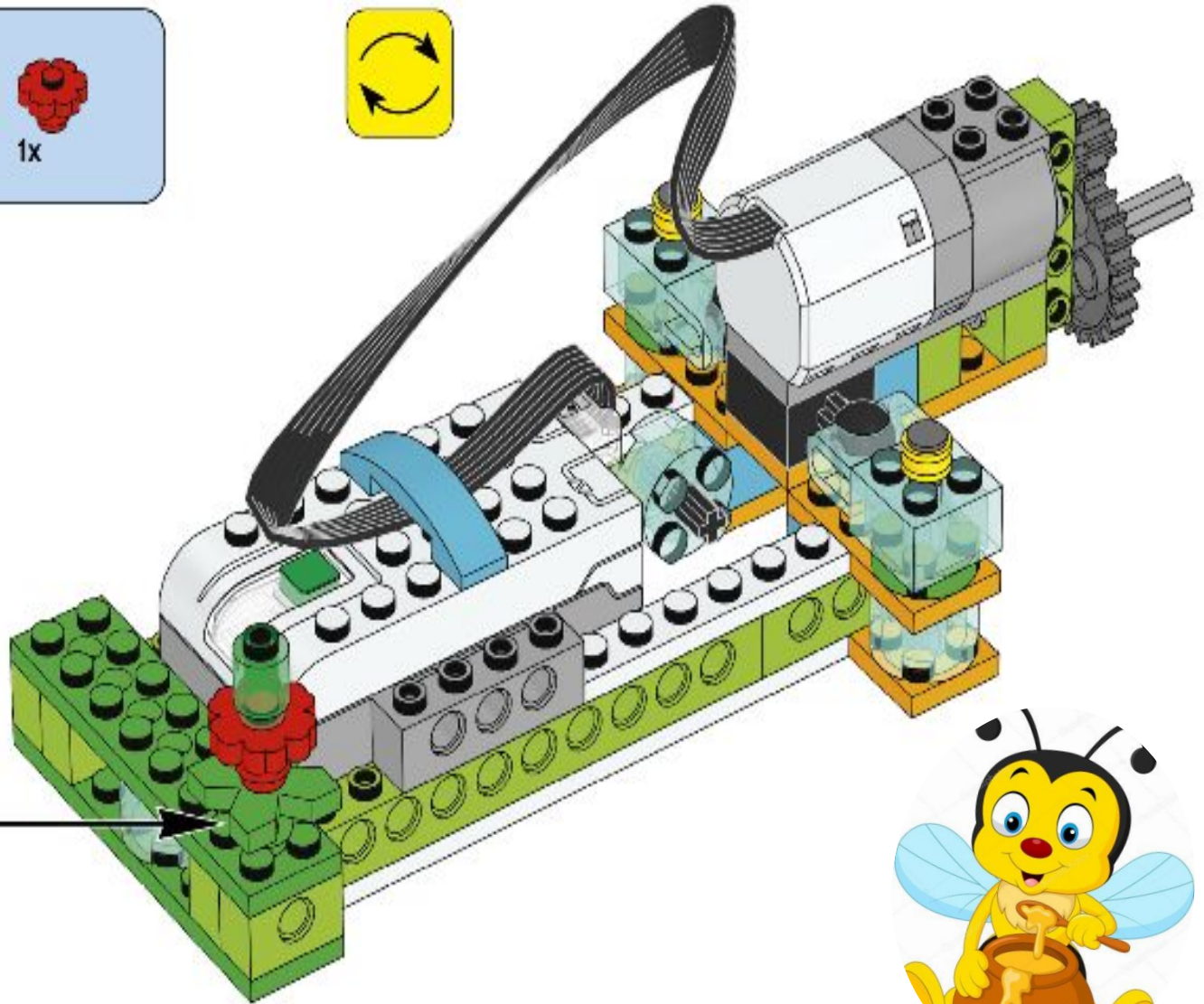
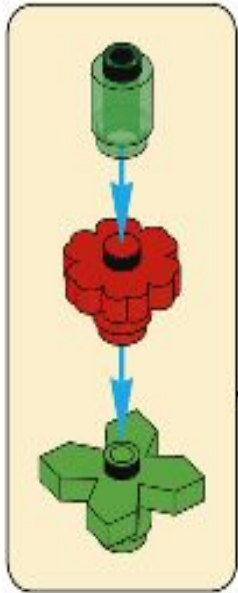

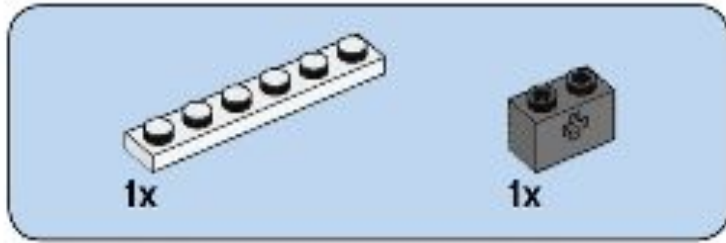

24

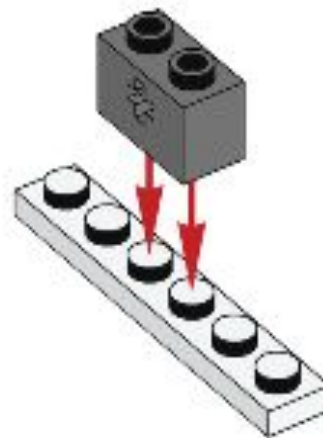

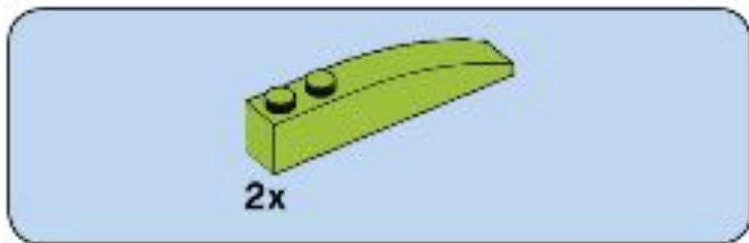

25

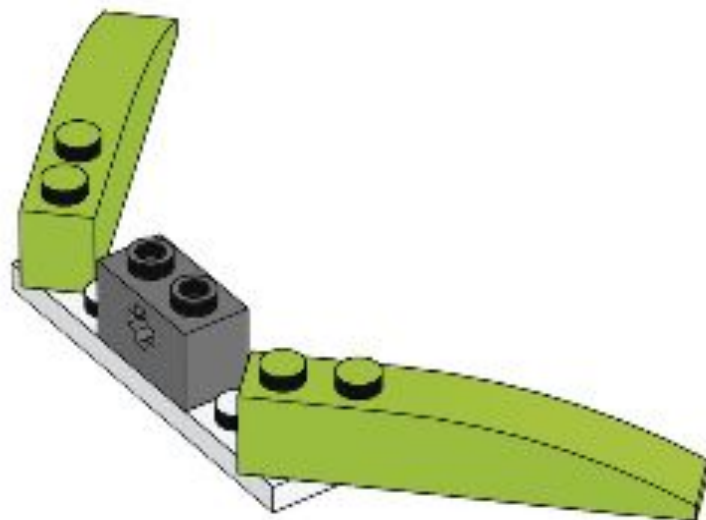

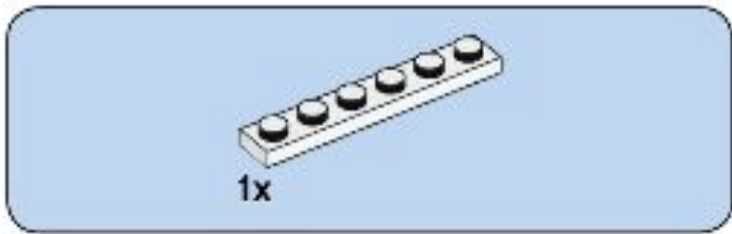

26

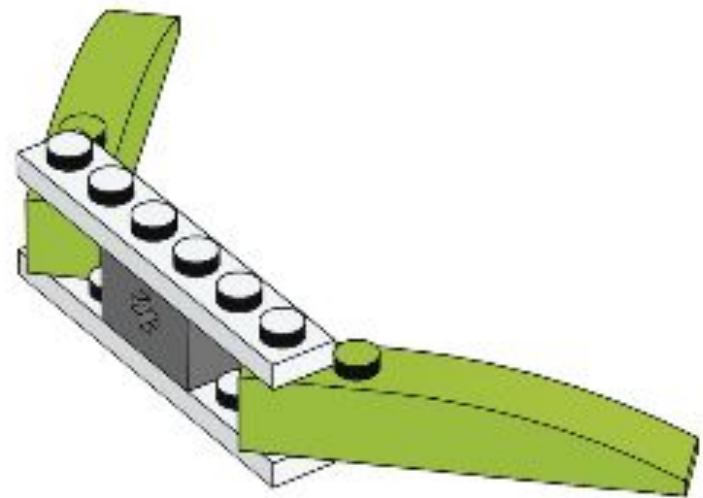

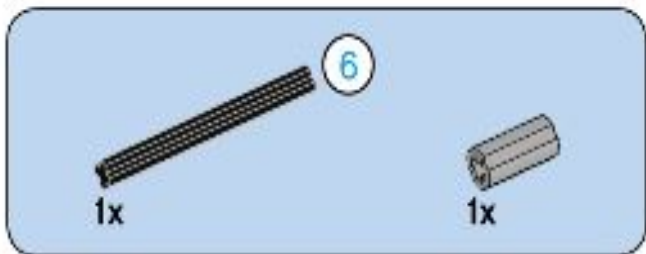

27

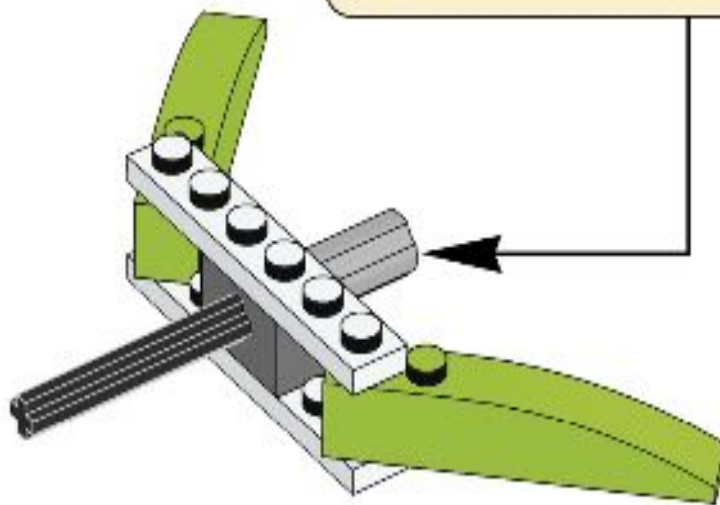
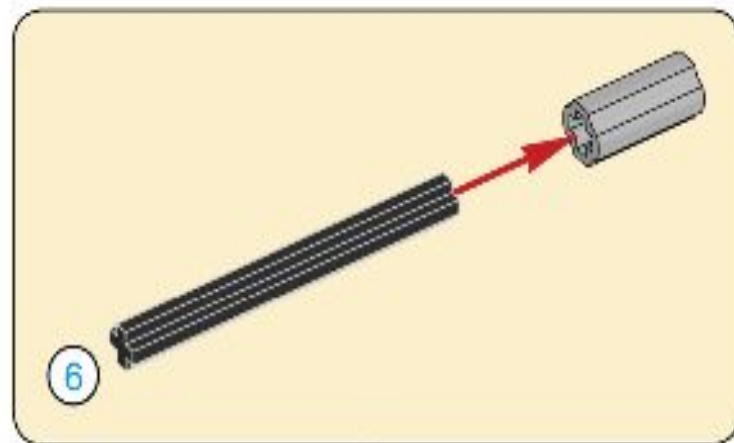



1x

28

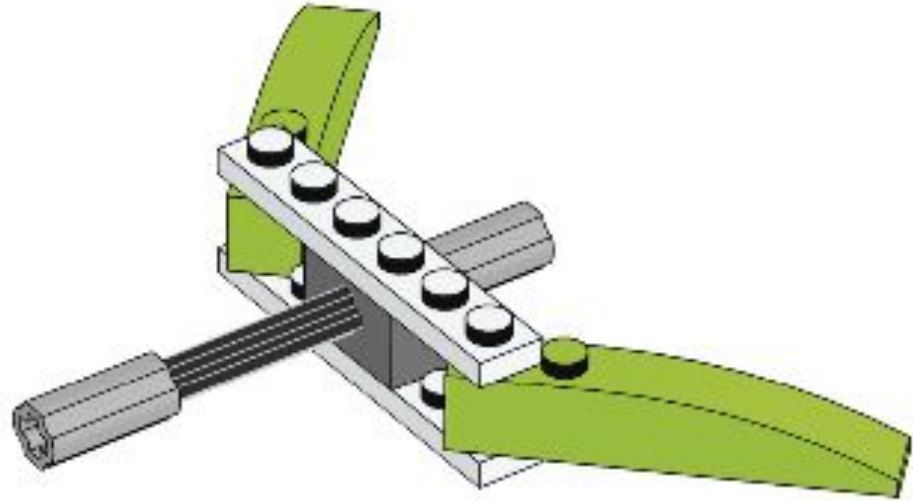

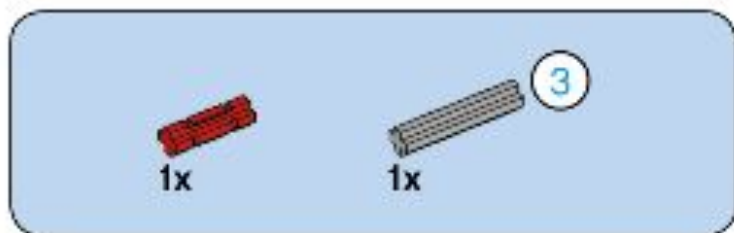

29

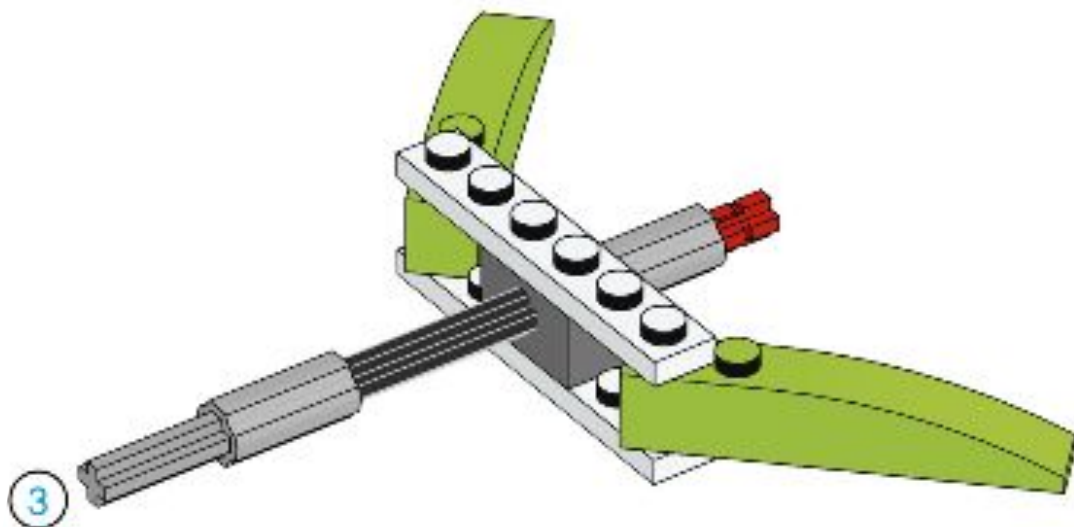

30

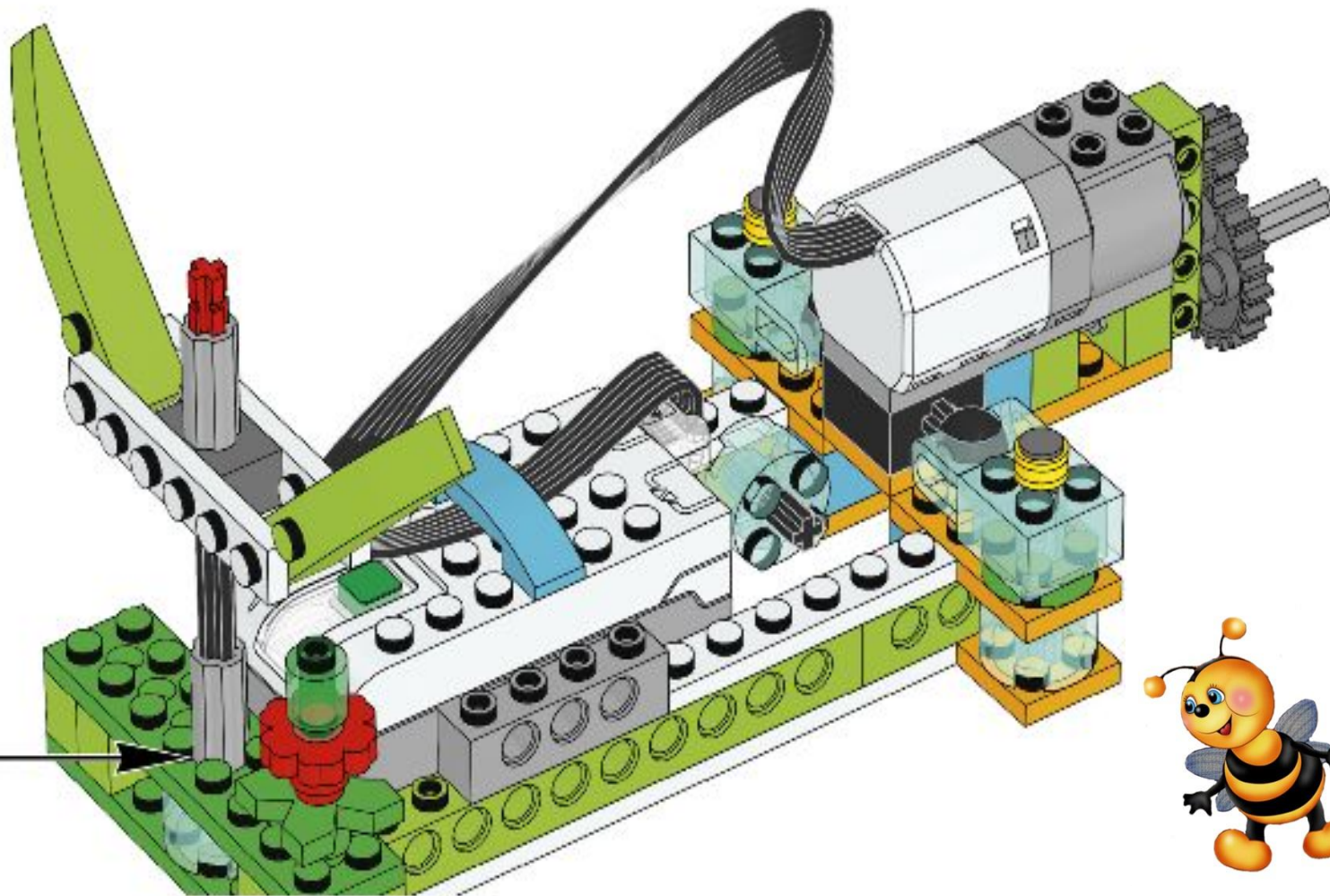

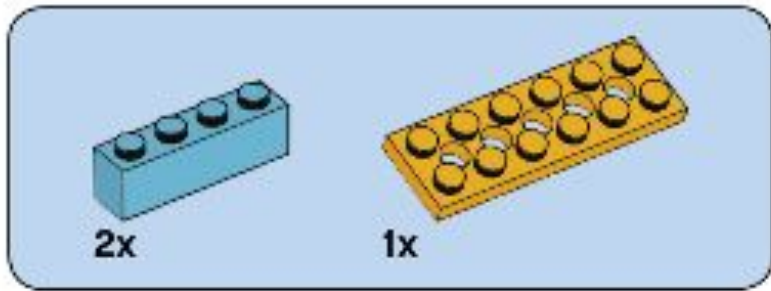

31

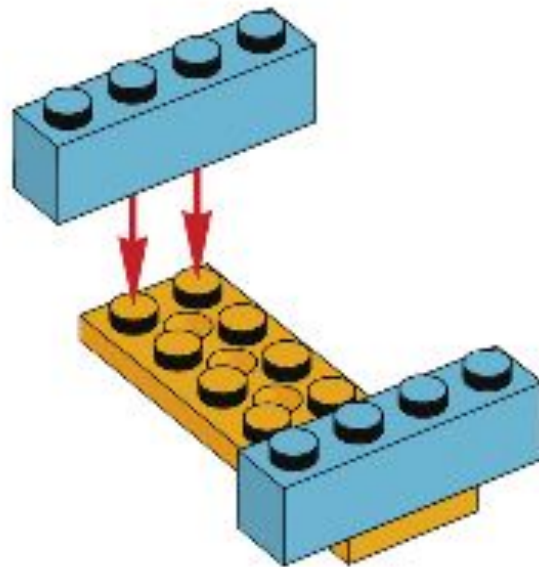

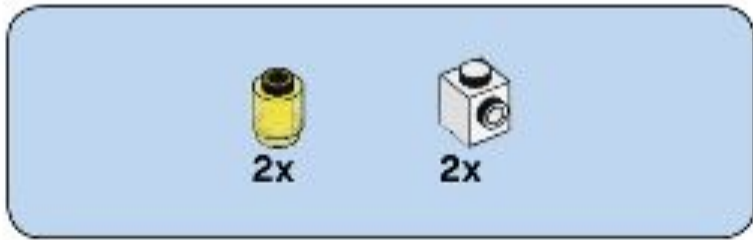

32

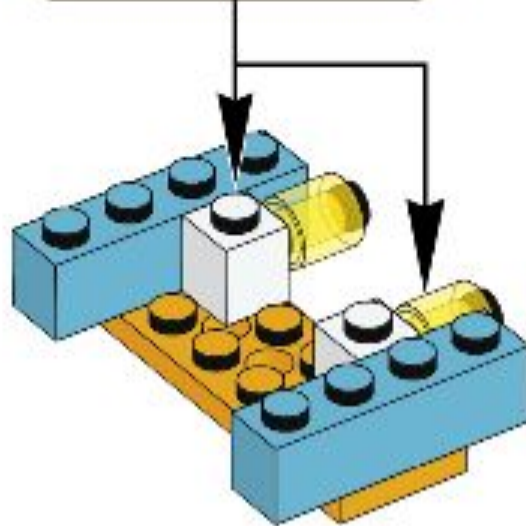
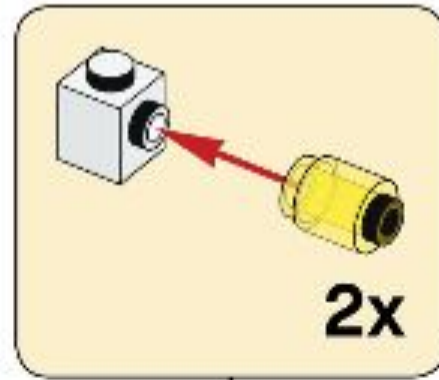
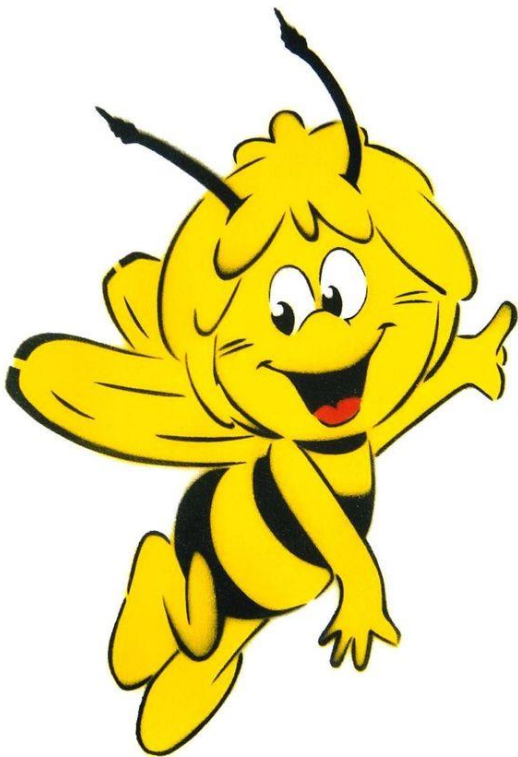

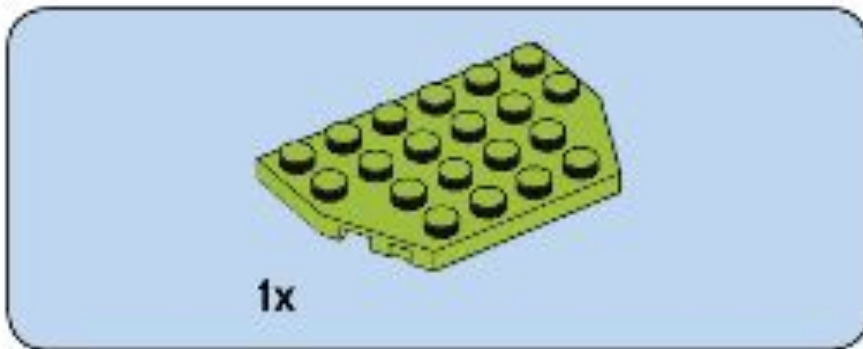

33

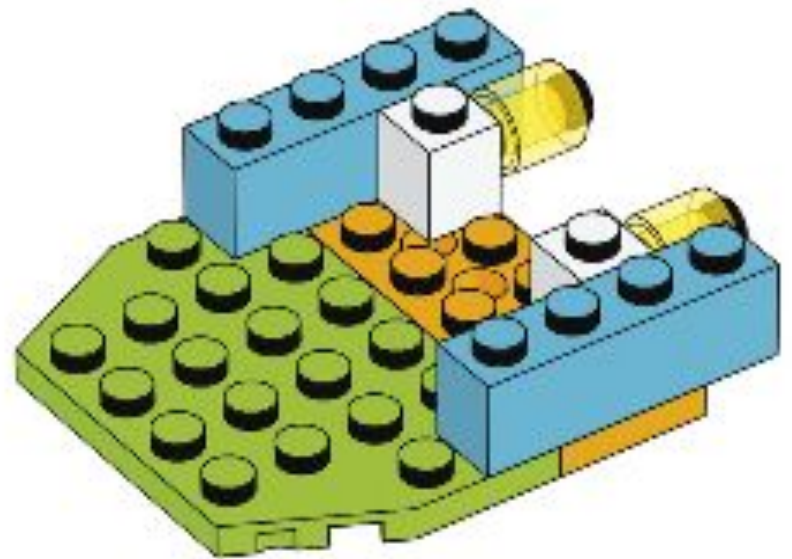



1x



2x

34

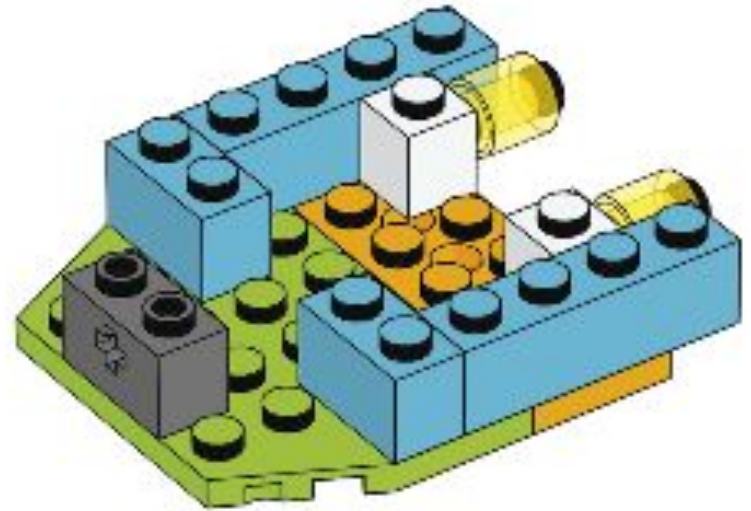

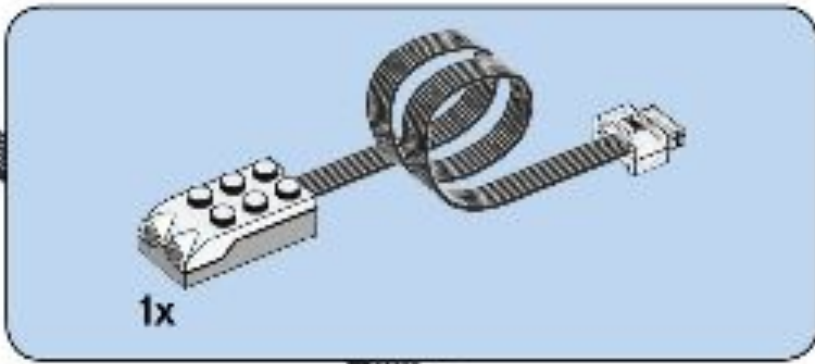

35

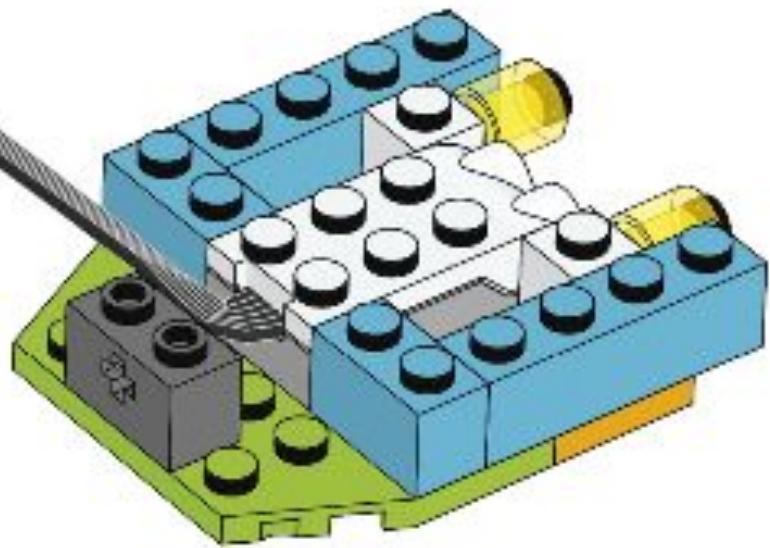

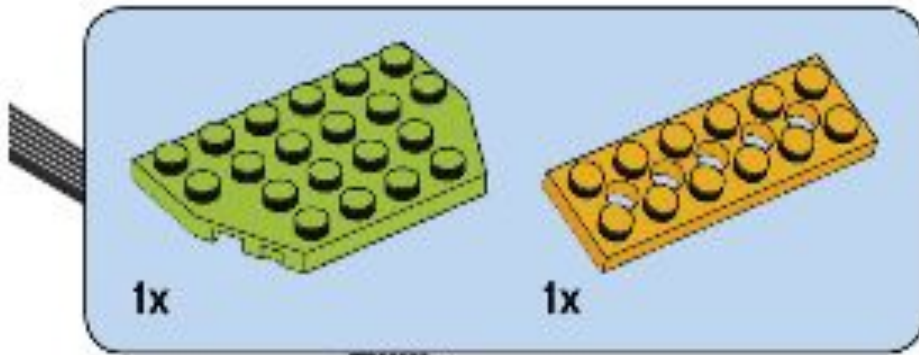

36

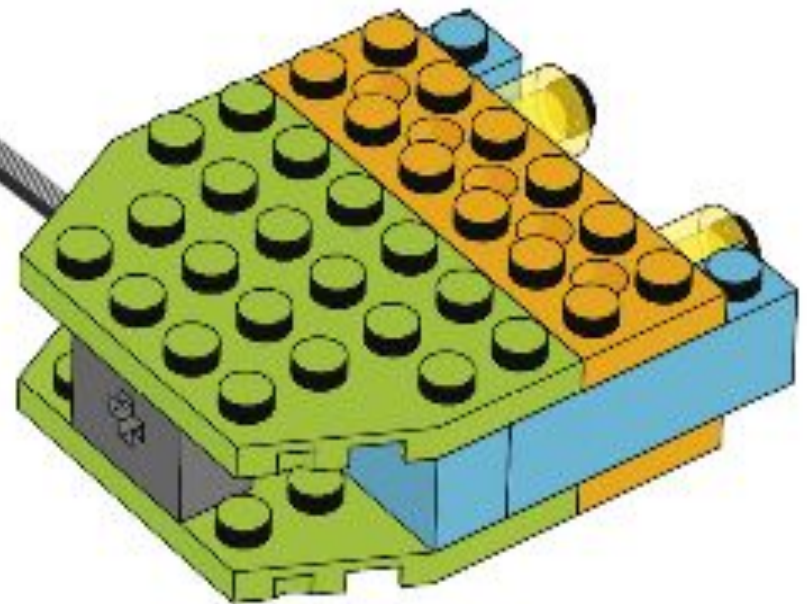

37

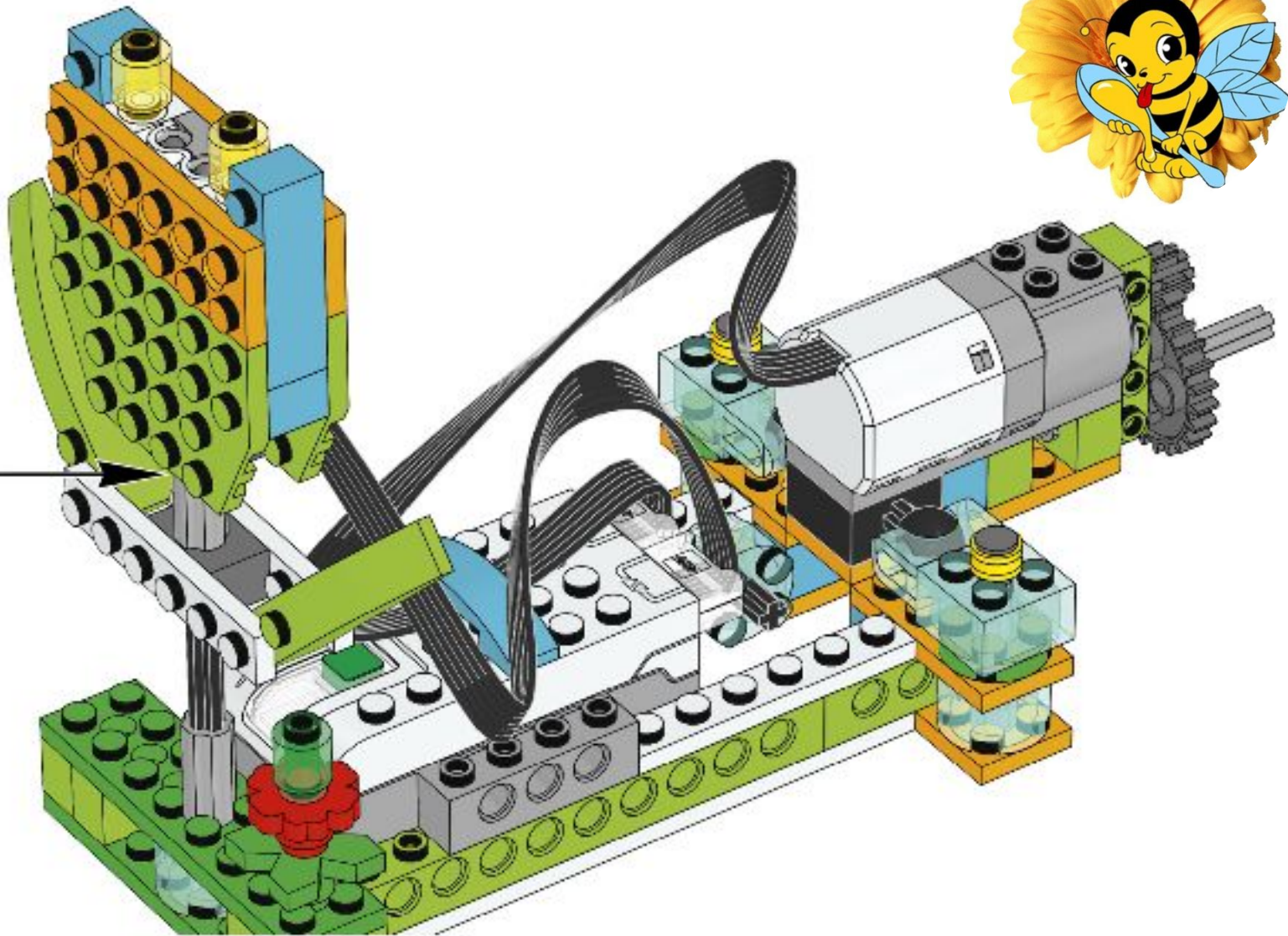

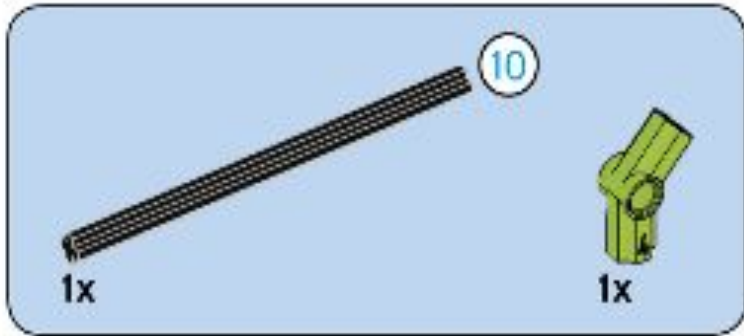

38



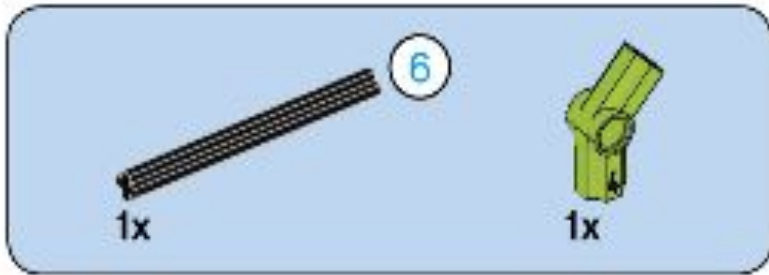

39



40

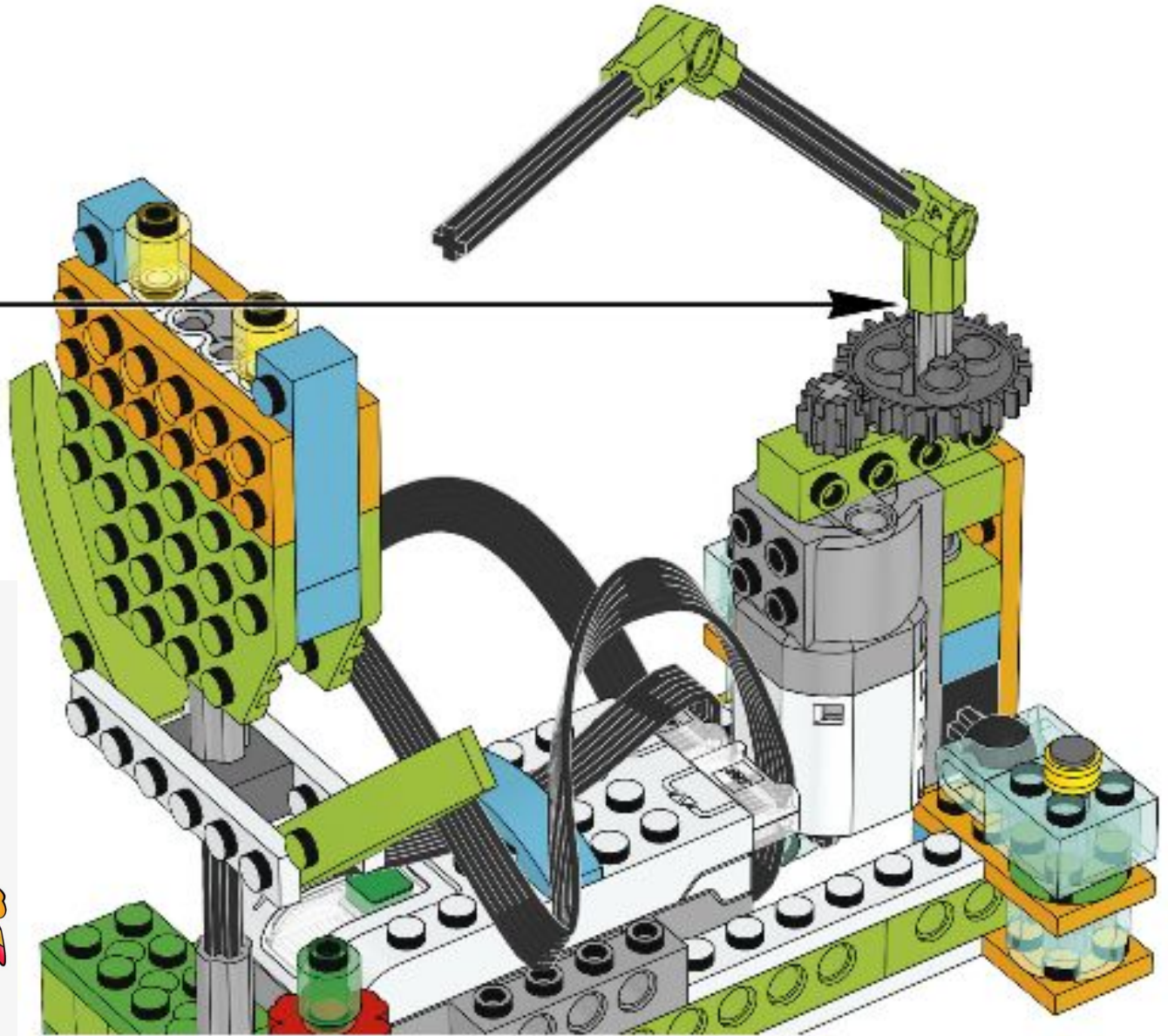

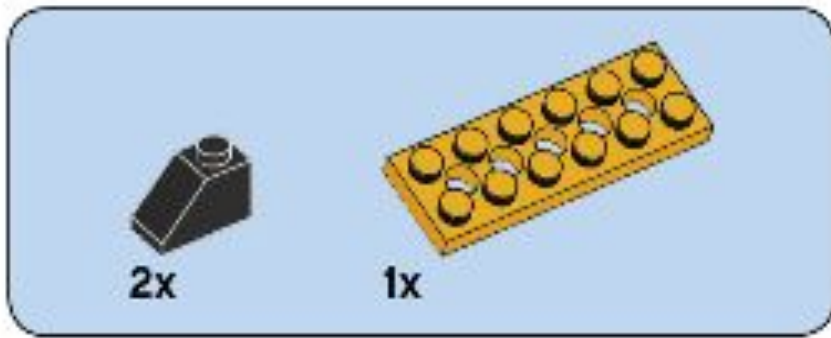

41

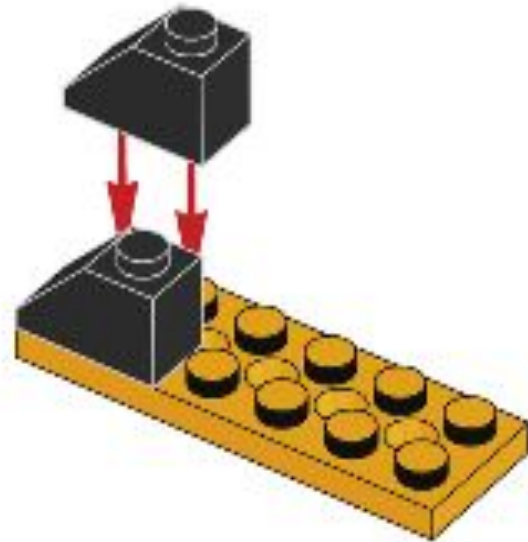



1x

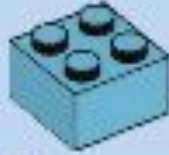

1x

42

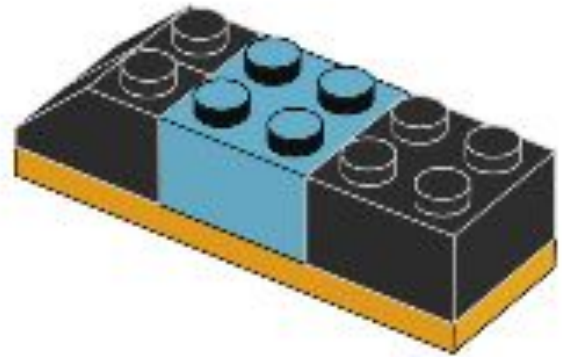



2x

43

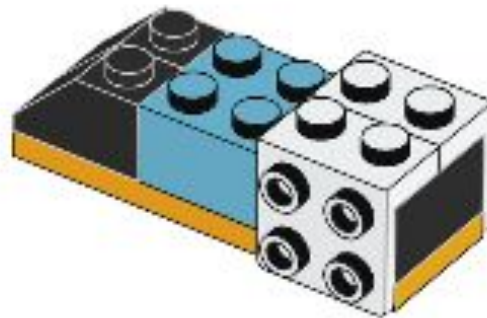

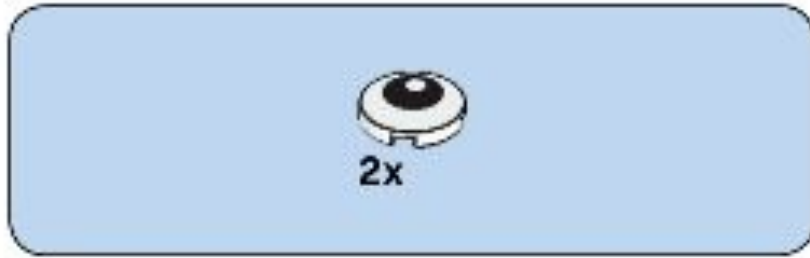

44

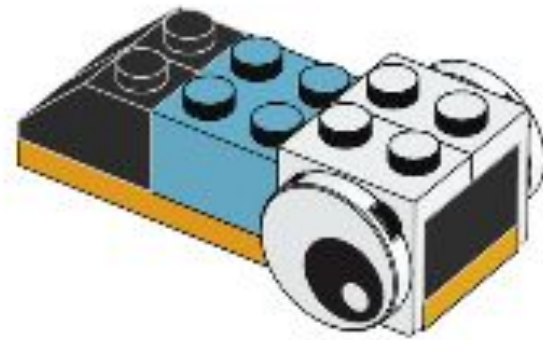



1x

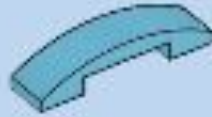

1x

45

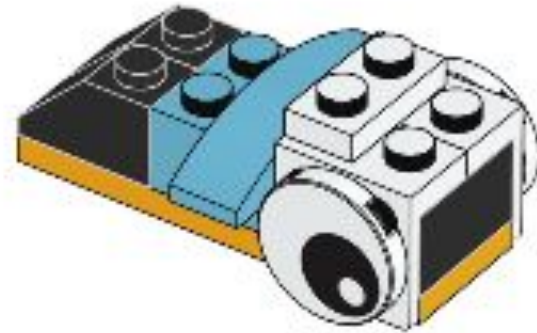

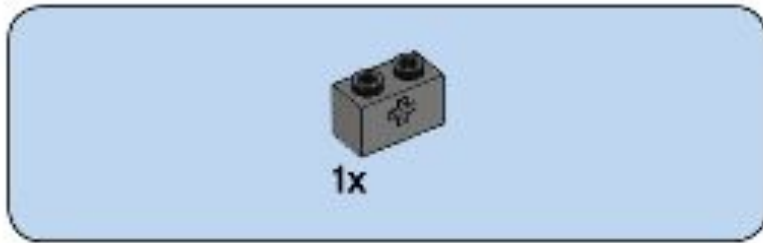

46

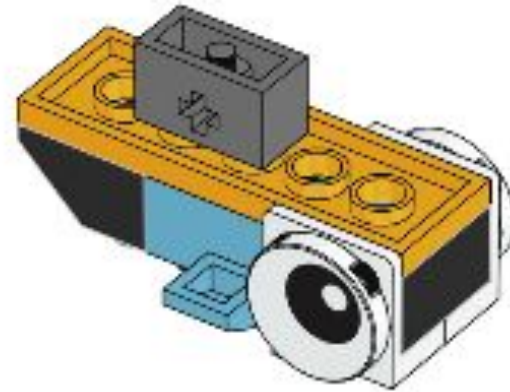



47

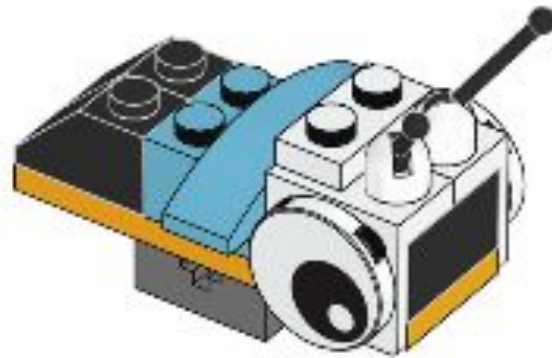

48

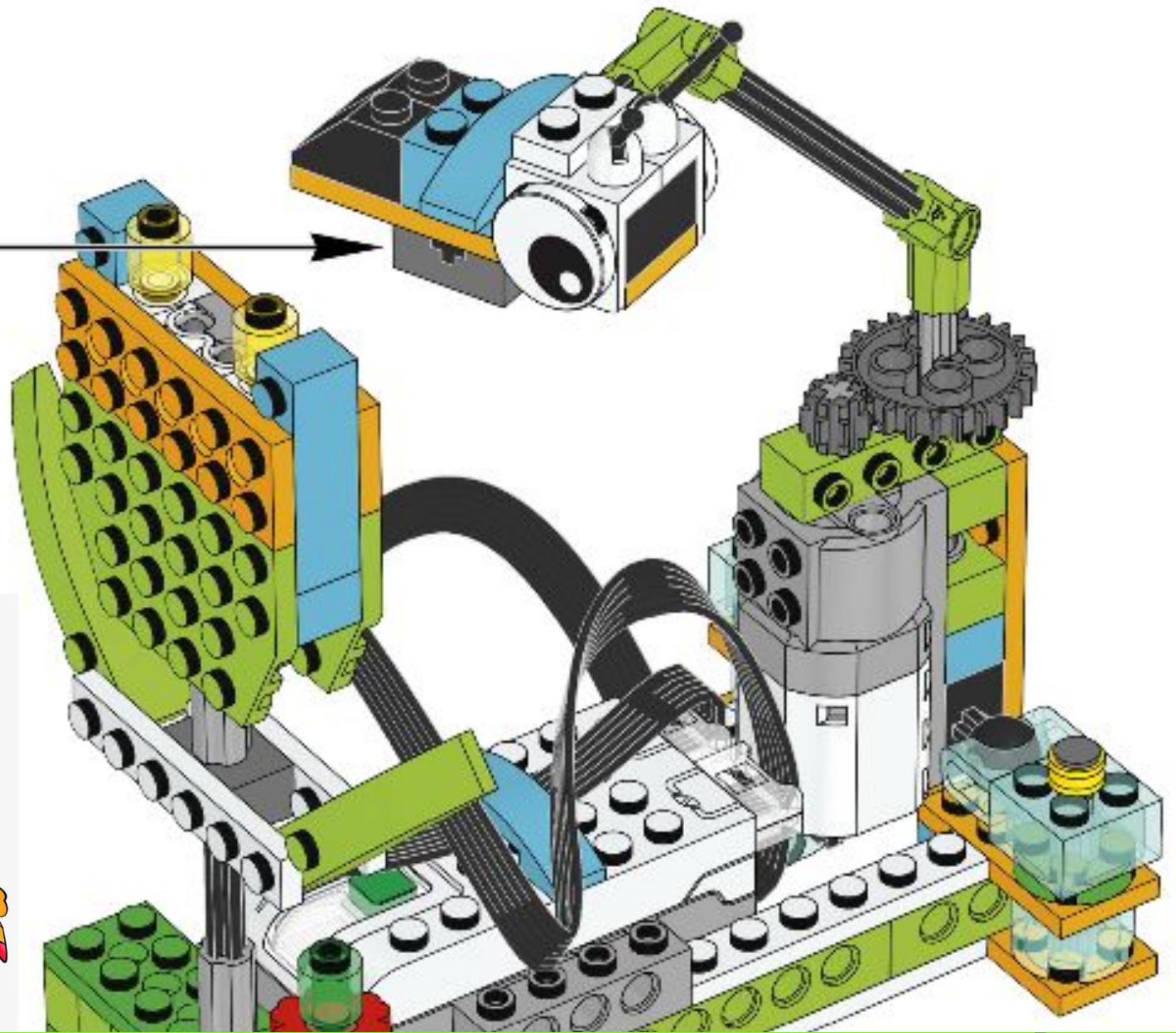

Используя блоки программного обеспечения конструктора «LEGO=WeDo 2.0 составим программу работы модели.



Найдите ответы на вопросы нашего занятия

- 1.Какие детали использованы при конструировании модели?**
- 2.Какие детали приводят модель в действие?**
- 3.Какие блоки программирования использованы при программировании?**
- 4.Опишите алгоритм работы модели?**

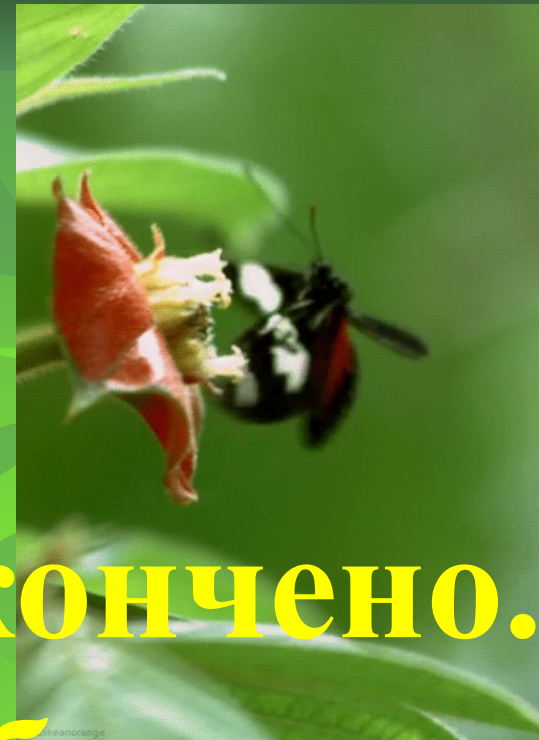

Наше занятие закончено.
Спасибо за работу.

