

Name of discipline:

Transmission systems of access
networks
(TSAN)

Lecturer - Oreshkov Vasiliy Ivanovich

Organizational matters:

1. The teachers:

- Oreshkov Vasiliy Ivanovich ,
- Makarov Igor Vladimirovich.

2. The number of lessons :

- Lecture – 14 (weekly),
- Laboratory work – 7 (on even weeks),
- Practice – 7 (on odd weeks) .

3. Final control – CREDIT!

For credit is necessary:

- to protect the laboratory work,
- to protect the complex task,
- attending lectures and to have lecture notes

4. In addition to a monthly attestation will be carried out flash testing.

INTRODUCTION

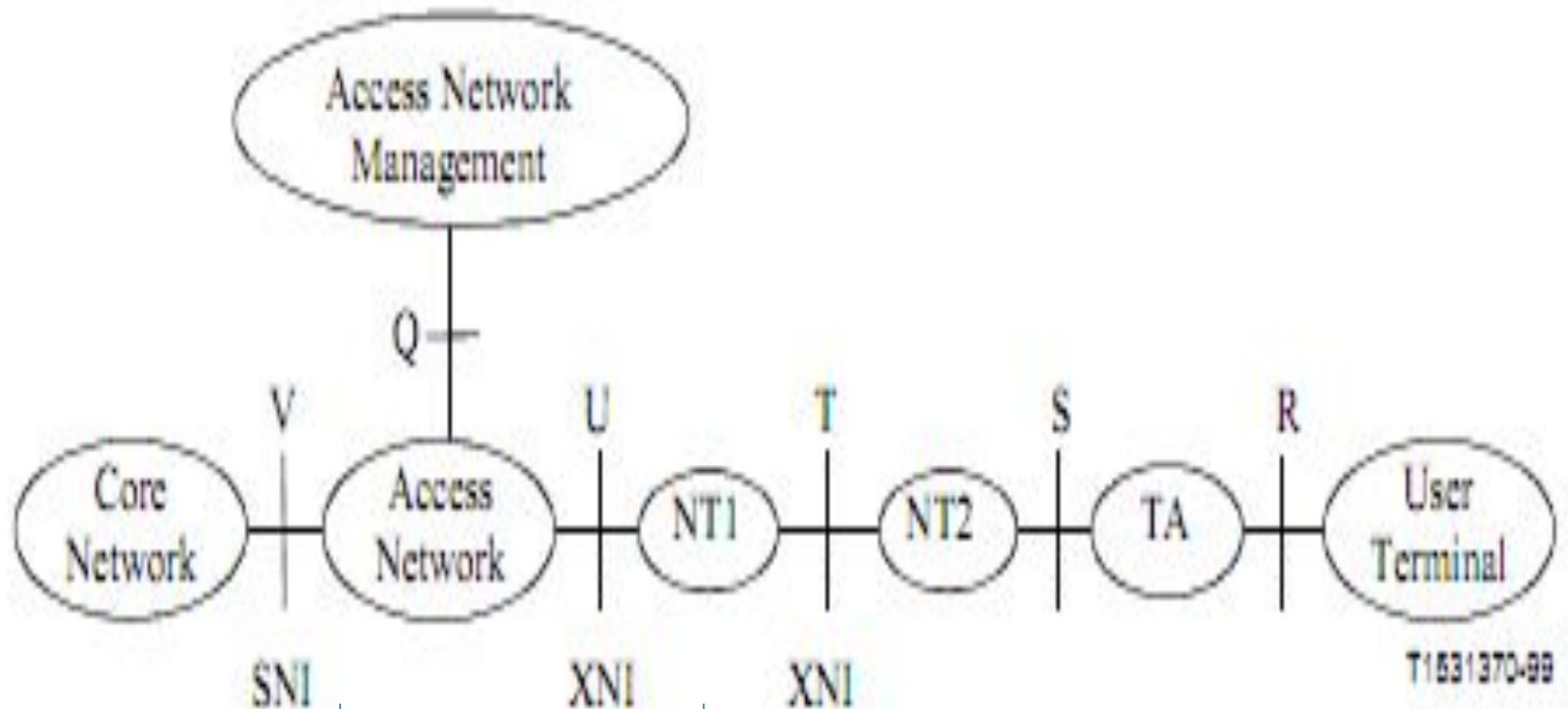

part of the network studied in the
TSAN course

Fig. 1 A reference configuration for a generic subscriber's
access

This reference configuration identifies the reference points in the context of access network.

The generic reference configuration consists of seven elements:

- 1) Core Network.
- 2) Access Network.
- 3) Network Termination 1 (NT1).
- 4) Network Termination 2 (NT2).
- 5) Terminal Adapter (TA).
- 6) User Terminal.
- 7) Access Network Management.

Core Network and Access Networks are separated at the V interface.

Access Network Management Element depicts the management functionalities.

Access Network and the Access Network Management elements are separated at the Q reference point.

The NT1 makes physical connection to the Access Network at the U reference point, and provides service presentation to a customer on a logical or physical interface at the T reference point.

The NT1 terminates the Access Digital Section of the Broadband connection allowing management and performance monitoring.

An NT1 may not terminate the transport protocol (e.g. ATM) for user traffic, but may implement transport protocol functions such as rate adaptation required to support different T/U reference point/interface characteristics.

An NT2 connects to the network at the T reference point, may connect to multiple user terminals on S reference point interfaces.

The NT2 terminates the transport protocol (e.g. ATM) for user traffic, and may implement switching/routing functions.

The NT2 may be integrated with an NT1 to form an NT1/2.

The NT term is used for generic Network Termination for various services.

For some services it could be part of the Access Network and for others not.

The inclusion of the NT in the Access Network and vice versa does not necessarily imply the ownership.

A TA adapts the transport protocol to the specific requirements of a user terminal.

One or more of the elements in the reference configuration may be null in some scenarios; therefore, one or more of these reference points may be merged.

The reference points may also correspond to the functional interfaces, although, existence of a physical interface is not implied.

Some of these reference point/interface are the subject of ITU-T G.99x-series Recommendations, whether by inclusion or by reference to other Recommendations or specifications.

When two or more functional groupings are present in a real device, the interface between them need not be exposed, even if it is the subject of these Recommendations.

There may be more than one interface specification for each of these reference points.

The exact interpretation at these reference points will depend upon the local network architecture and regulatory environment.

The reference configurations in this clause show abstract functional groupings, which may or may not correspond to real devices.

Real devices may comprise one abstract functional grouping, more than one abstract functional grouping or a portion of an abstract functional grouping.

CLASSIFICATION OF ACCESS SYSTEMS AND NETWORKS

The classification of AN can be done by the following features:

- by the type of used guiding medium ;
- by the number of used for the connection wires pairs ;
- by way of linking - simplex, half duplex, duplex;
- by type of traffic - symmetric and asymmetric.

Classification by GM type

Guiding medium for AN can be:

- paired or quartile (star) twist symmetrical cable (SC);
- a wires pair of broadcasting network;
- a wires pair for power network;
- coaxial cable (CC);
- optical fiber (OF) of optical cable (OC);
- radio channel (requires a license for the radio frequency);
- atmospheric optical channel (does not require licensing).

Fig. 2.1 shows the classification of AN by type of used wired network of AS and the number of wires pairs (optical fibers).

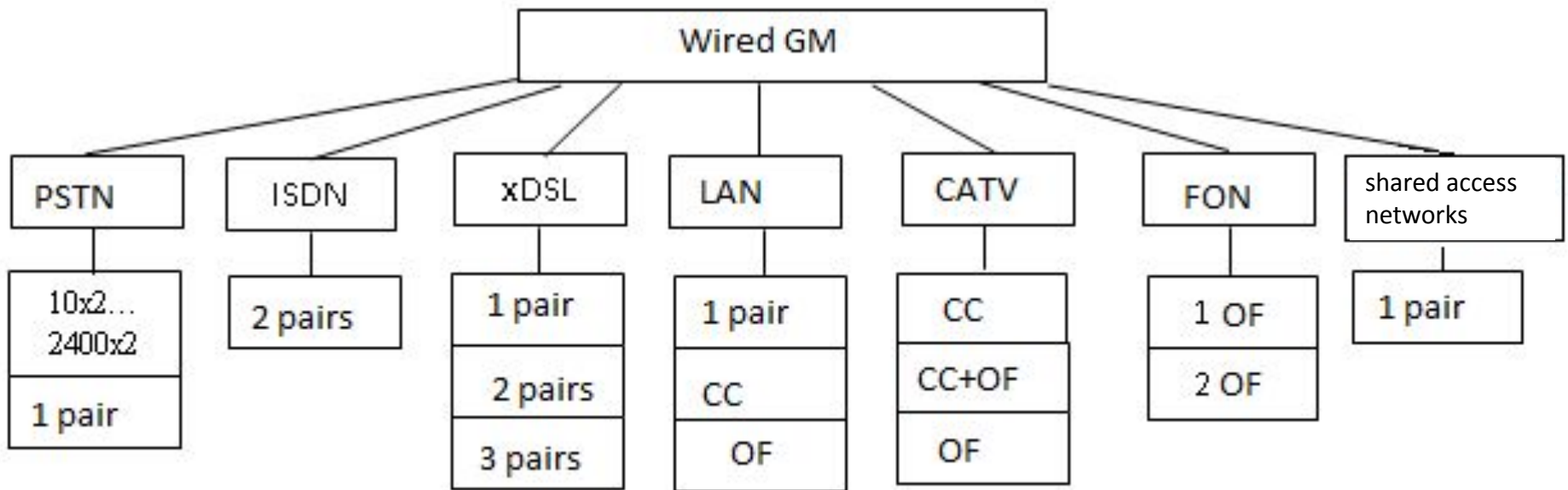

Notes to Fig. 2:

1. In PSTN cables with twisted pair conductors type ТПП with the number of pairs from 10 to 2400 are used, but for the organization of one DSL a single pair is used (regenerators are not used);
2. In the ISDN standard - Integrate Services Digital Network two pairs of conductors is required;
3. In xDSL technology - Digital Subscriber Line / Loop one or two pairs of conductors (rarely – three) are more commonly used;

4. LAN - Local Area Network may be constructed on the basis of the special symmetrical HF cable type "twisted pair", coaxial cable or optical fibers (depending on the transmission rate and standard of LAN);

5. In systems of cable TV (CATV) CC is traditionally used. Large systems CTV in big cities are built on a hybrid "fiber-coaxial technology." In future systems CTV OF will come into the room the user;

6. In fiber optic networks optical fiber is used;

7. To shared access networks except the PSTN refer radio broadcasting network and power network.