

Launch Umbilical Tower

PRINT ON CARDSTOCK

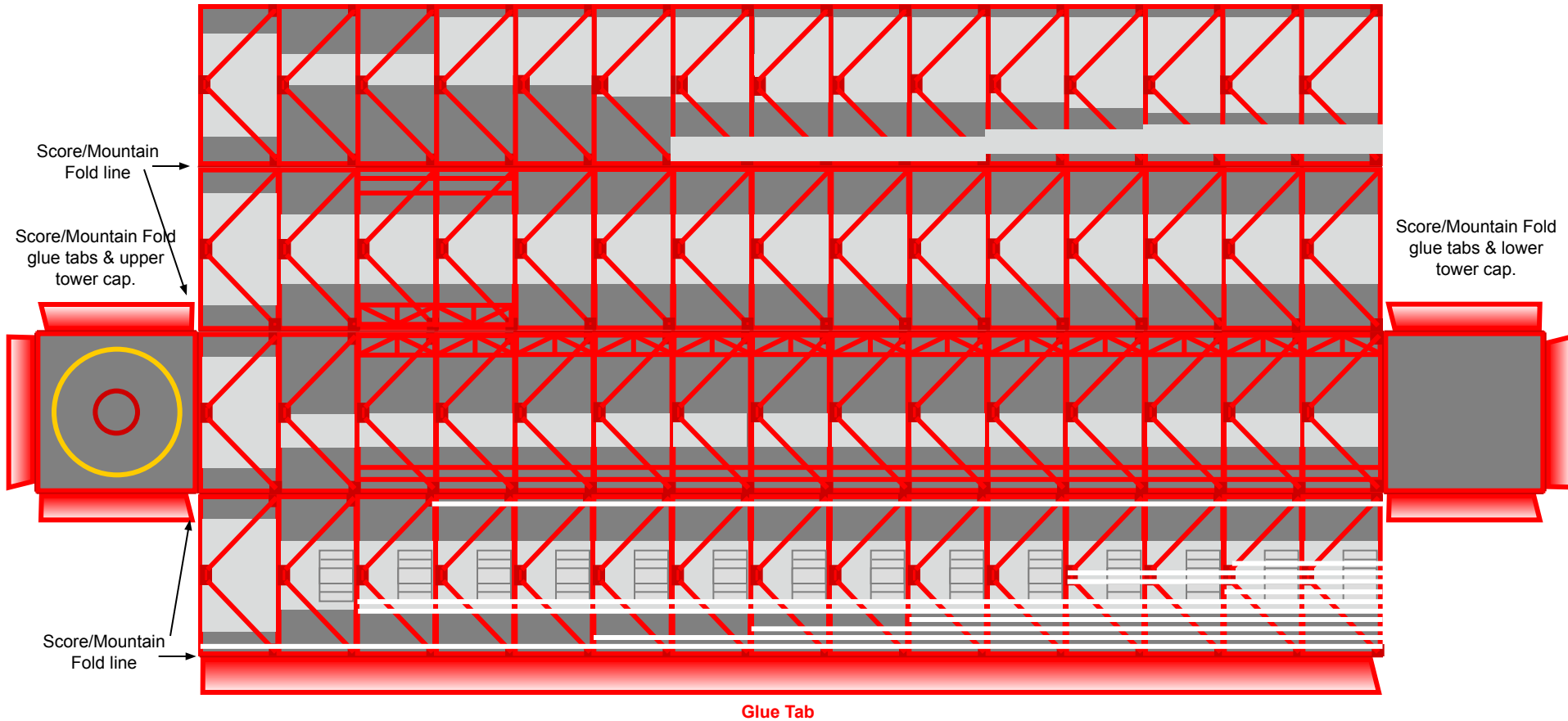

As the Crane is designed to rotate, the builder may wish to build it from cardstock for extra strength. You need build only one crane – these are alternate parts

Lightning Rod

Roll into tube

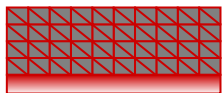

Mountain fold all triangular glue tabs on both ends

Machinery House

Mountain Fold/Score lines



© 2005 Drawn by Michael Burke
This cardmodel is only for personal and not commercial use.

Crane Keel

Sandwich and glue both halves around cardstock

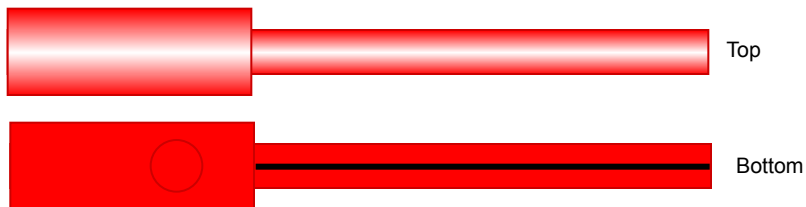

Print on Cardstock

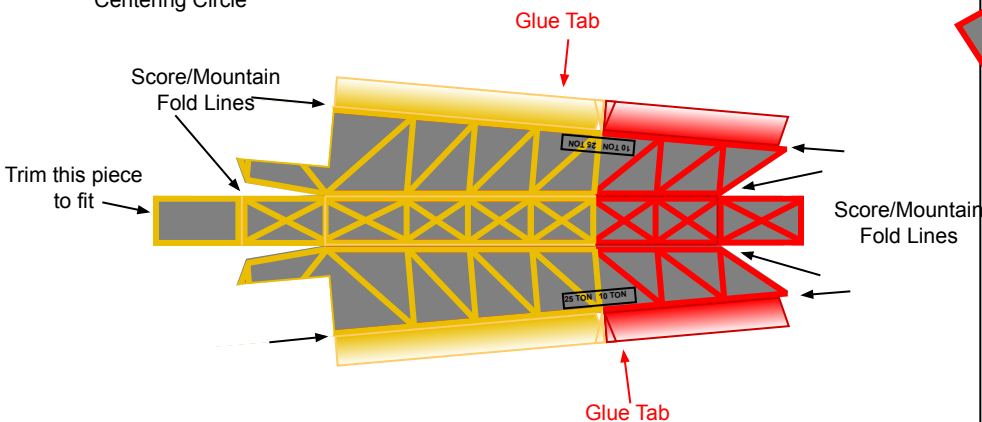

Denote Mountain Fold/Score Lines

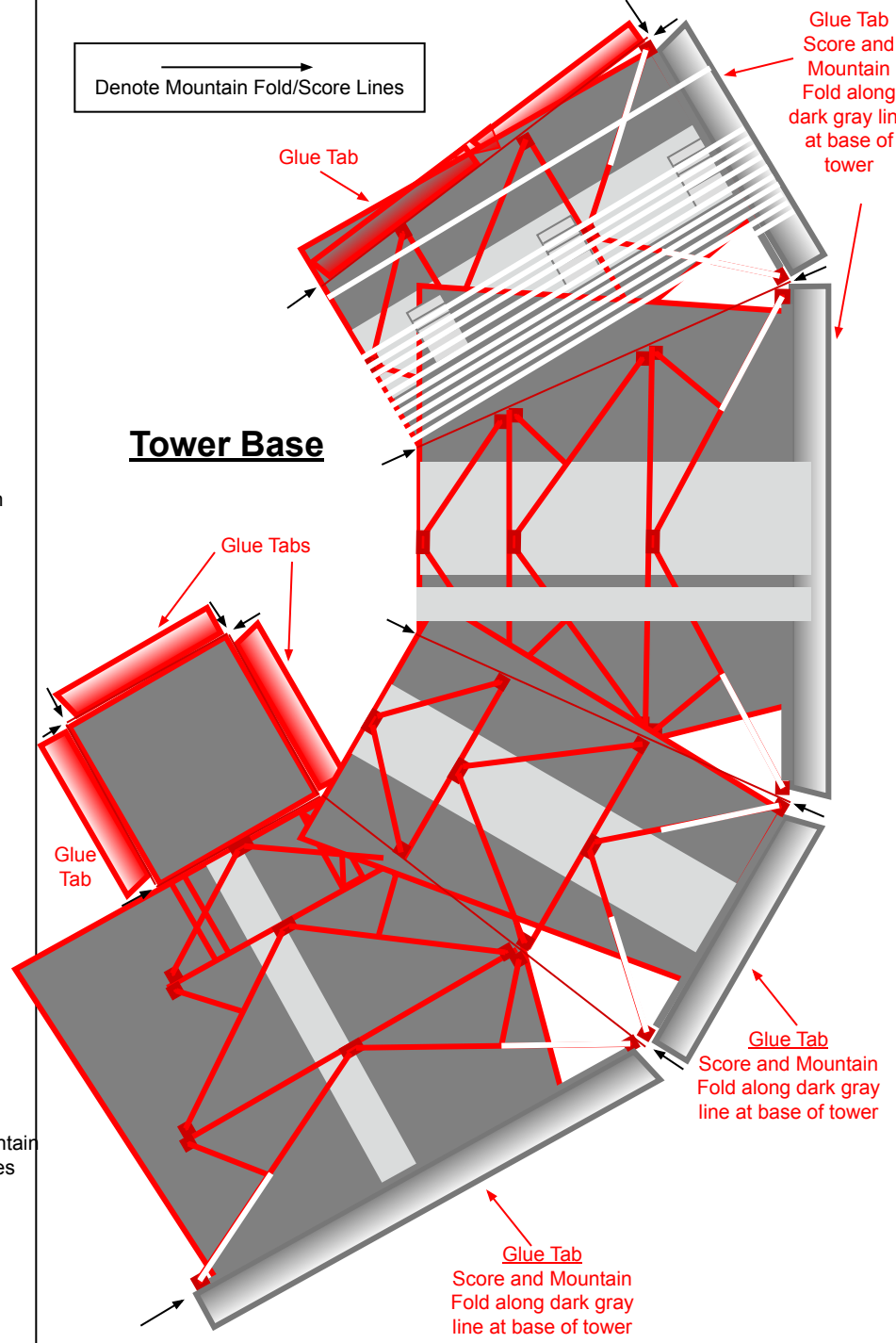

PRINT ON CARDSTOCK

Circles on underside of platform are for locating holes for tower pedestals. After platform is complete, carefully drill holes with tip of X-Acto knife. Insert pedestal tubes all the way to the underside of the top of the platform deck.

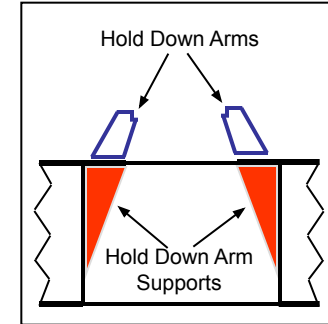
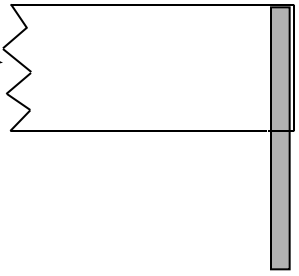
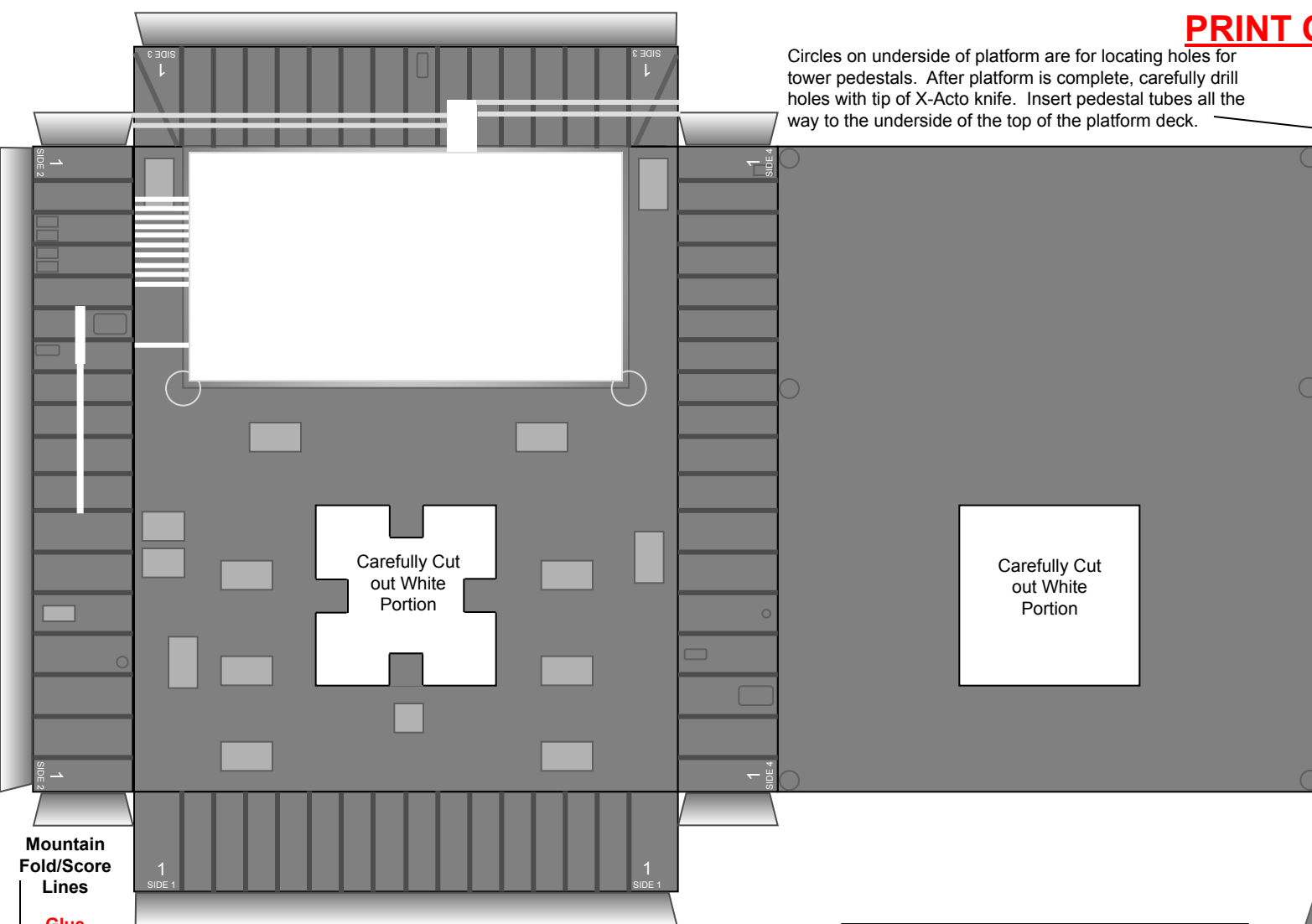

Hold-Down Arm Supports
These are wedge-shaped pieces that are glued to the underside of the square protrusions in the top opening of the thrust chamber and to the face of the thrust chamber liner.

Mountain Fold/Score Lines

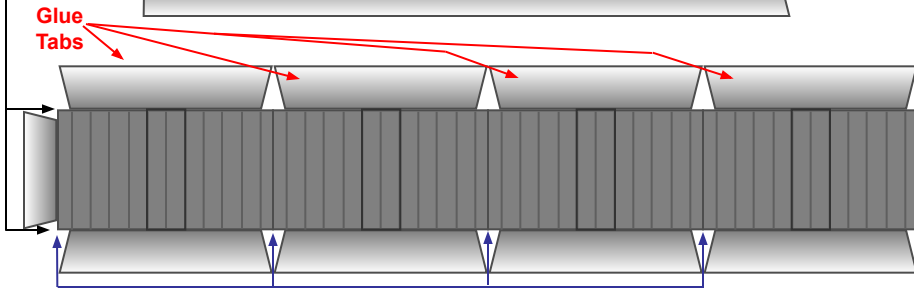

Valley Fold/Score Lines

Center in holes cut out of launcher platform, between upper and lower decks.

See Crane Parts Page for Hold Down Arms and Launcher Pedestals

© 2005 Drawn by Michael Burke
This cardmodel is only for personal and not commercial use.

All folds are Mountain folds.

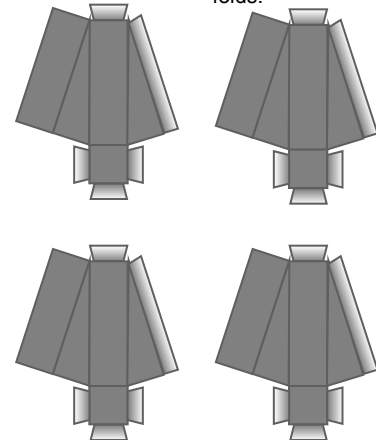

Service Arms

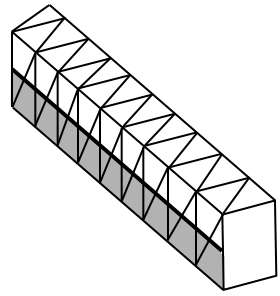

Solid red sections are the walkway (bottom) of the arm – gray section with diagonal cross members are the tops. Sides have diagonal cross members with "mesh" on bottom half.

Both ends are "capped" for rigidity and for mounting to the tower.

All folds are "mountain" folds.

Recommend printing on bond paper.

SM Arm

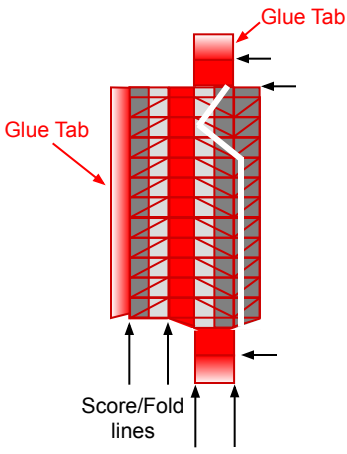

S-IVB Arms

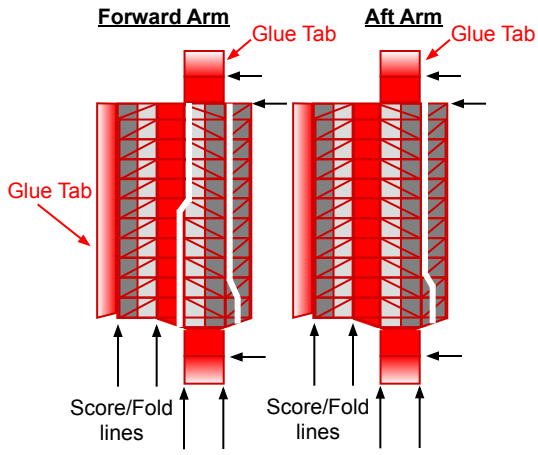

S-I & S-II Arms

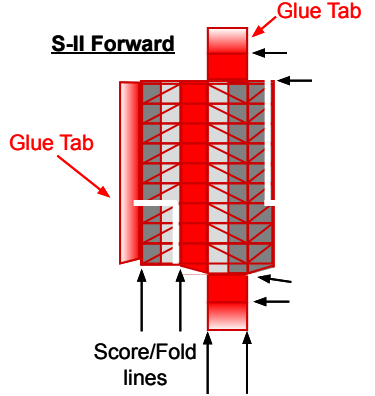

S-II Intermediate Arm

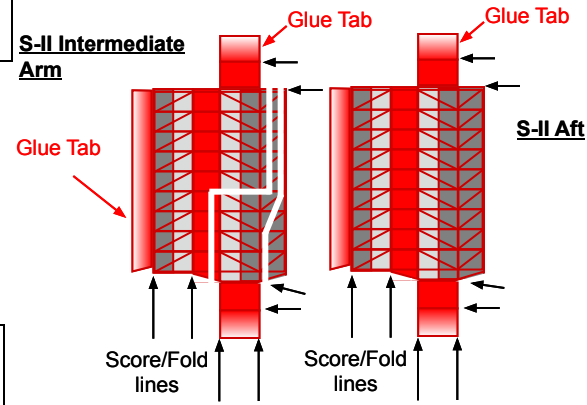

PRINT TO BOND PAPER

CM Access Arm

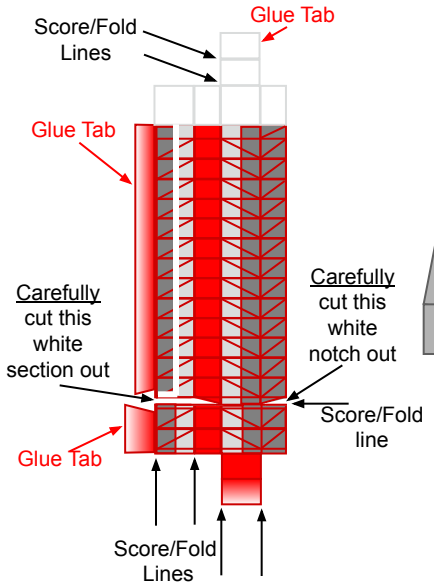

When CM Access Arm is complete, from the top, it should be shaped like and mounted to side of tower, like this.

Other arms are mounted to front of tower, like this. (See drawing for placement.)

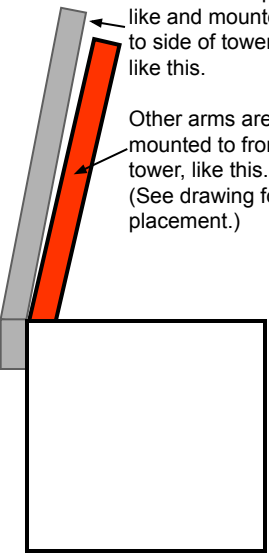

Damper Arm

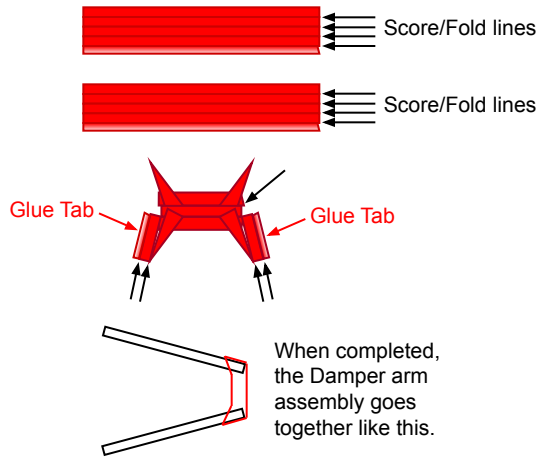

S-IC Forward

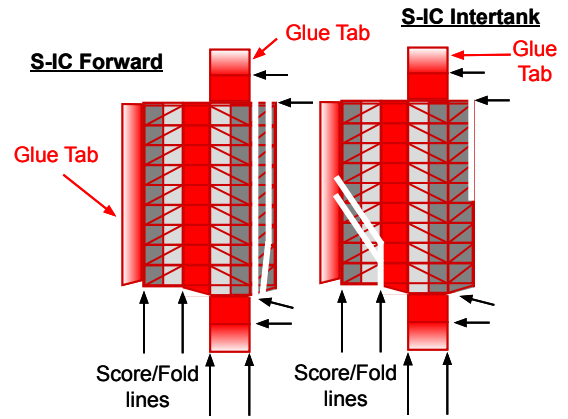

PRINT TO BOND BAPER

Launcher Base Pedestals

Roll into double layered tubes – Glue edge to centerline

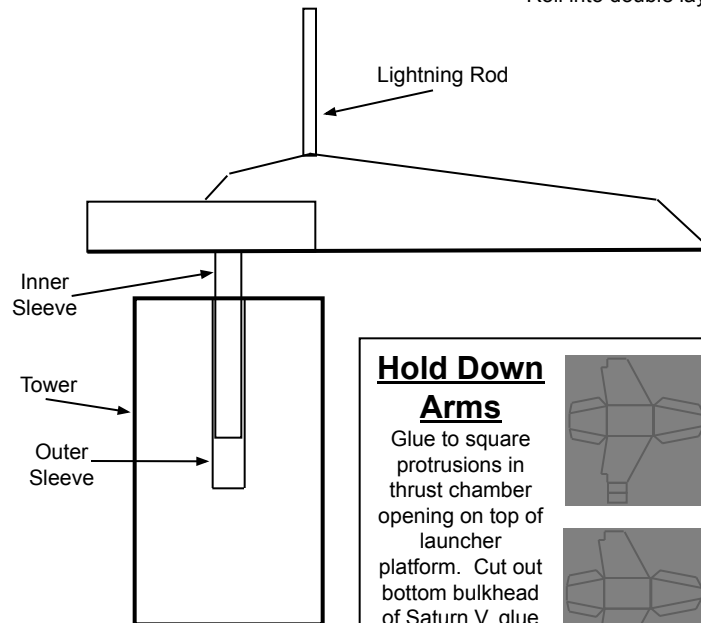
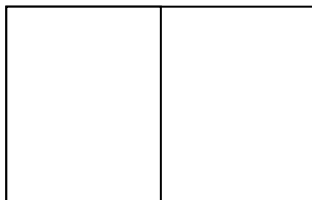
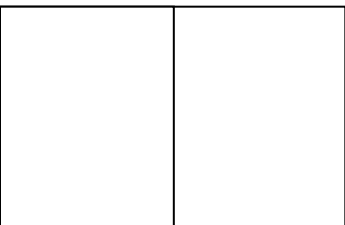

Outer Sleeve – Inside top of Tower

Roll into double layered tube – Glue edge to centerline.

Cut out small circle on top of tower, glue tube in line with hole in order to stabilize crane and allow it to rotate.

Inner Sleeve – on bottom of crane

Roll into double layered tube – Glue edge to centerline

Glue tube to bottom of Crane Keel, centered in small circle. Inner Sleeve should fit snugly enough inside Outer Sleeve that Crane doesn't wobble, but loosely enough to allow rotation.

Hold Down Arms

Glue to square protrusions in thrust chamber opening on top of launcher platform. Cut out bottom bulkhead of Saturn V, glue to cardstock, and use to align Hold Down Arms such that they are centered and support the rocket model.

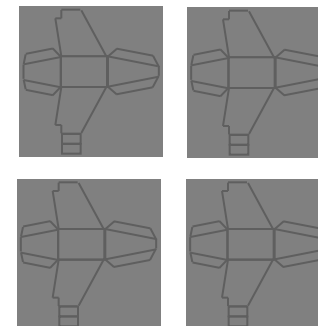

All lines are Score/Mountain Fold Lines

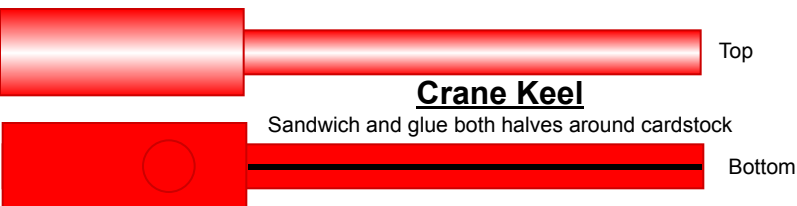

Lightning Rod

Roll into tube

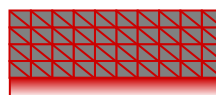

Crane Boom

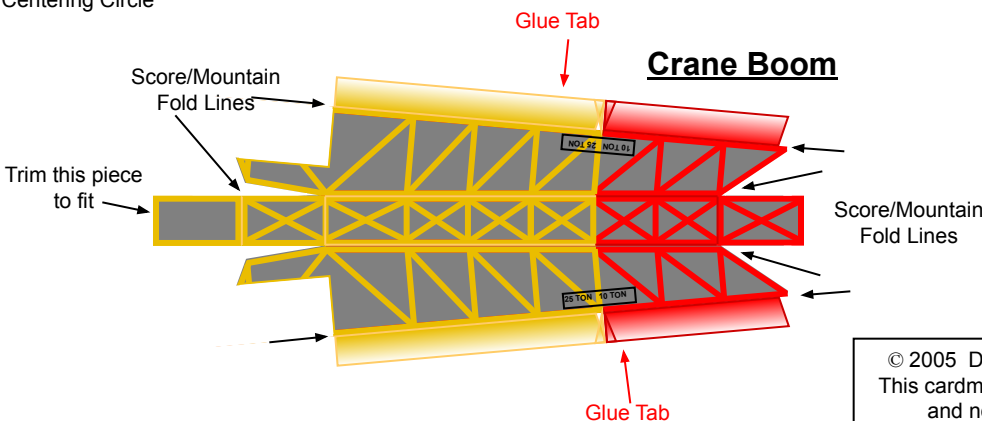

Machinery House

Mountain Fold/Score lines

Mountain fold all triangular glue tabs on both ends

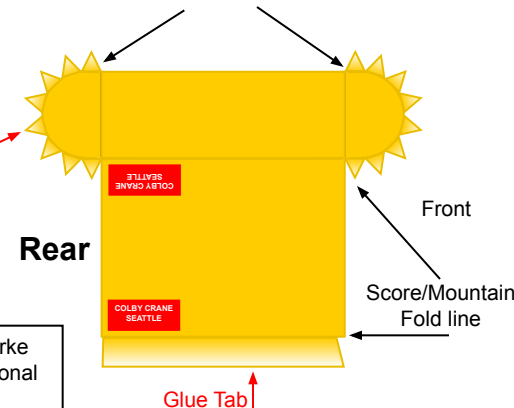

© 2005 Drawn by Michael Burke
This cardmodel is only for personal and not commercial use.

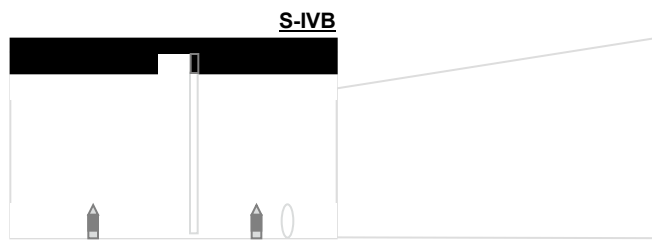

Roll Into double-layered tubes

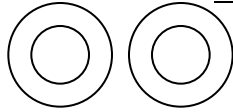

S-IVB Centering Rings

Glue Rings to Cardstock and glue one in front and one in back of S-IVB

S-IC, Interstage, & S-II

PRINT TO BOND BAPER

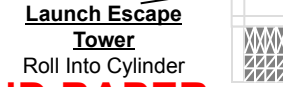

Launch Escape Tower
Roll Into Cylinder

Command Module



Service Module

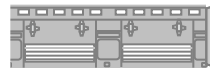

This wedge is a glue tab

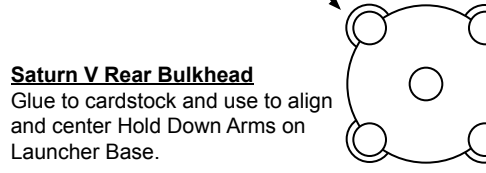
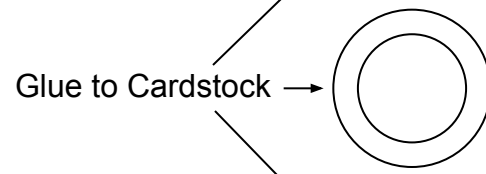
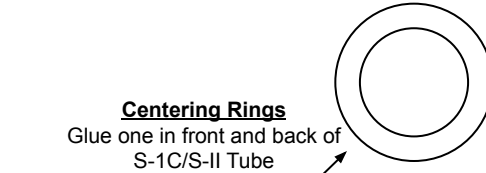
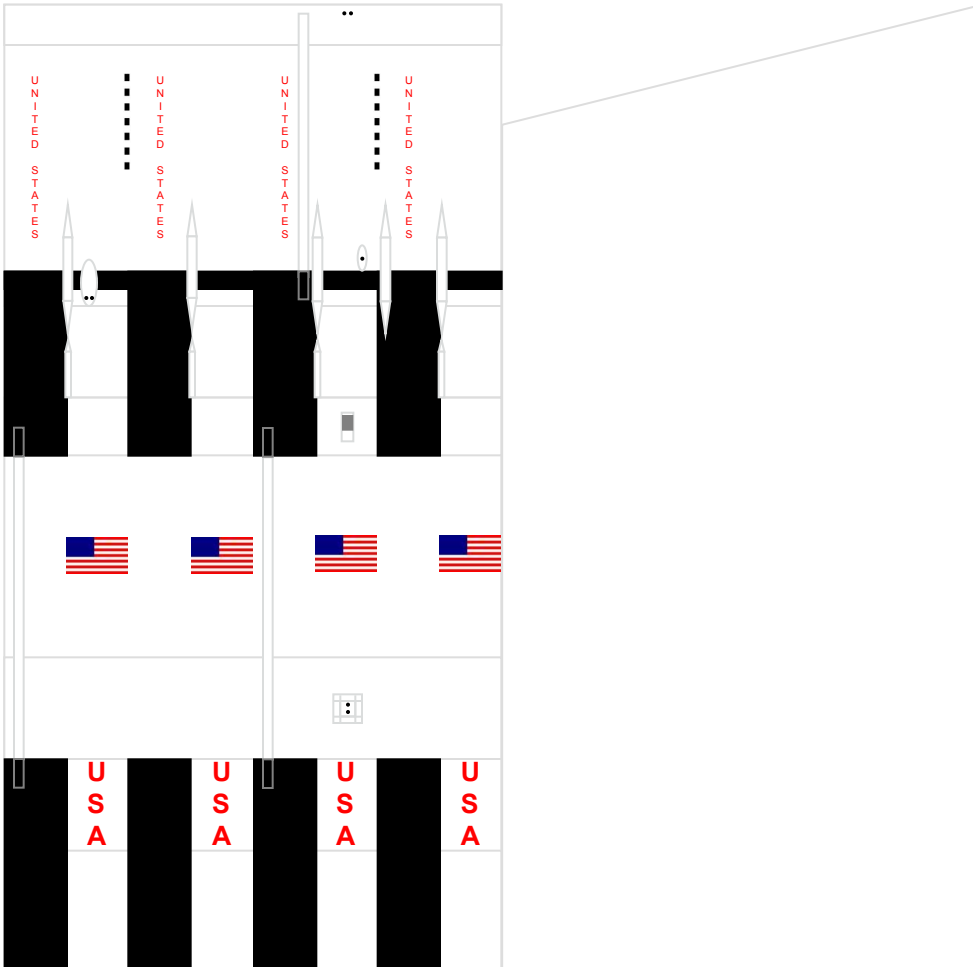
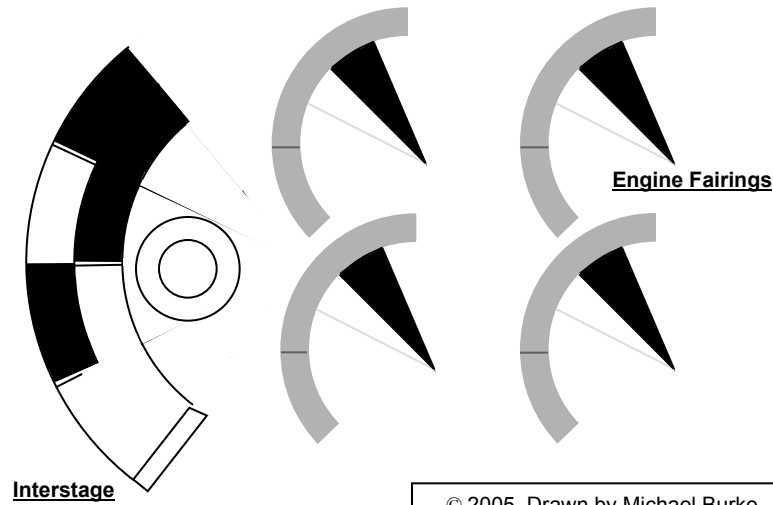

© 2005 Drawn by Michael Burke
This cardmodel is only for personal and not commercial use.

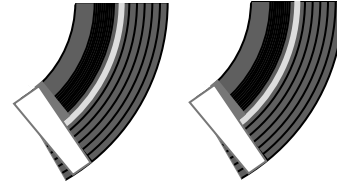
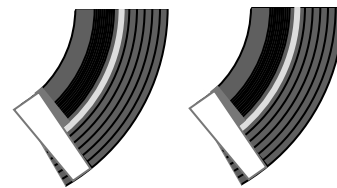

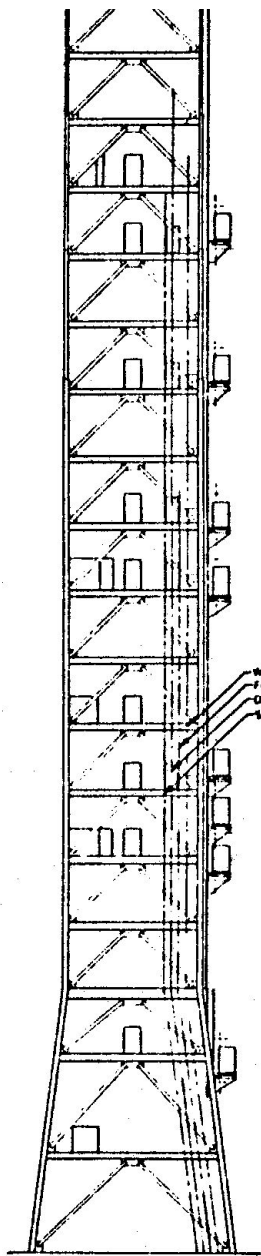

WEST ELEVATION
 SIDE (2)
 SCALE: 1/200

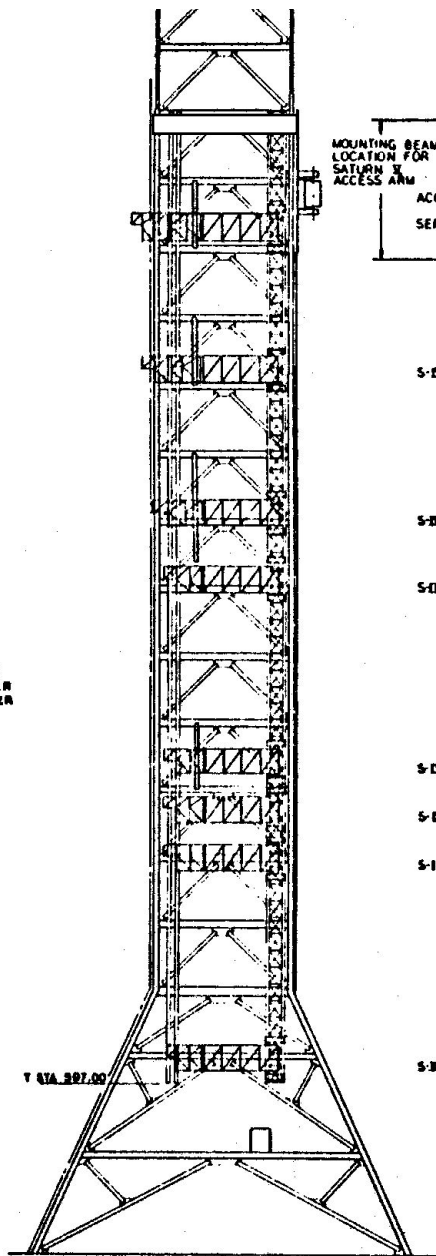

SOUTH ELEVATION
 SIDE (1)
 SCALE: 1/200

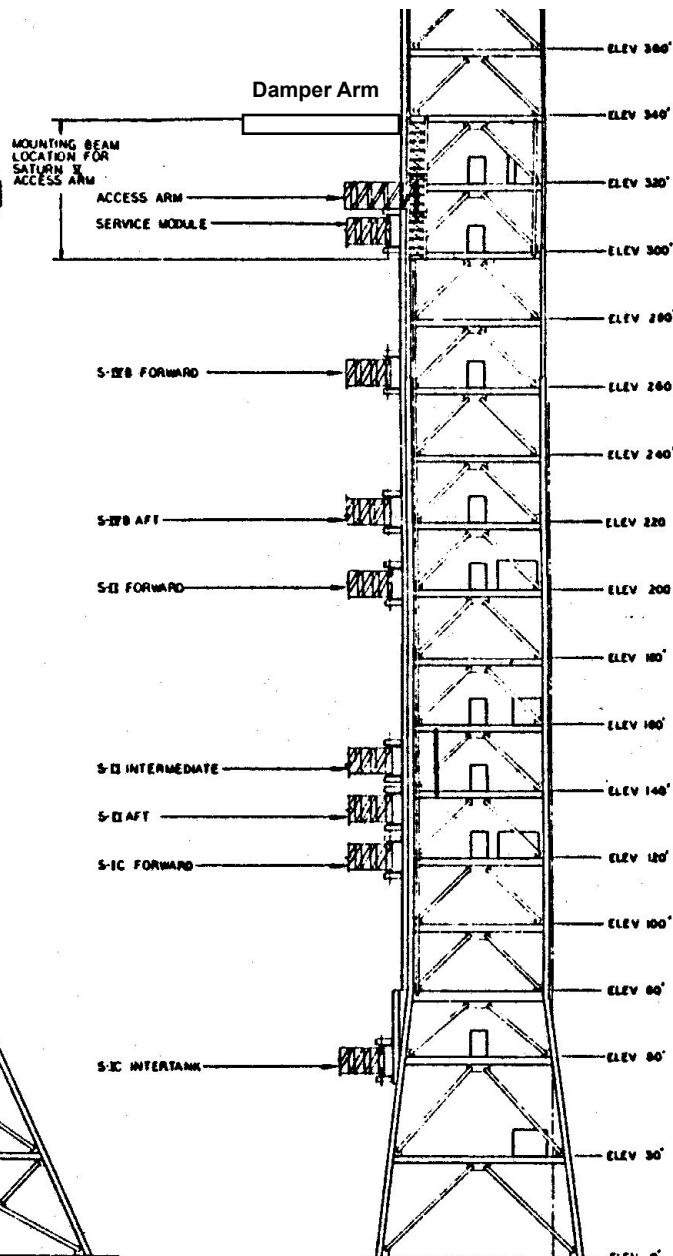

EAST ELEVATION
 SIDE (4)
 SCALE: 1/200
 ARMS SHOWN IN EXTENDED POSITION

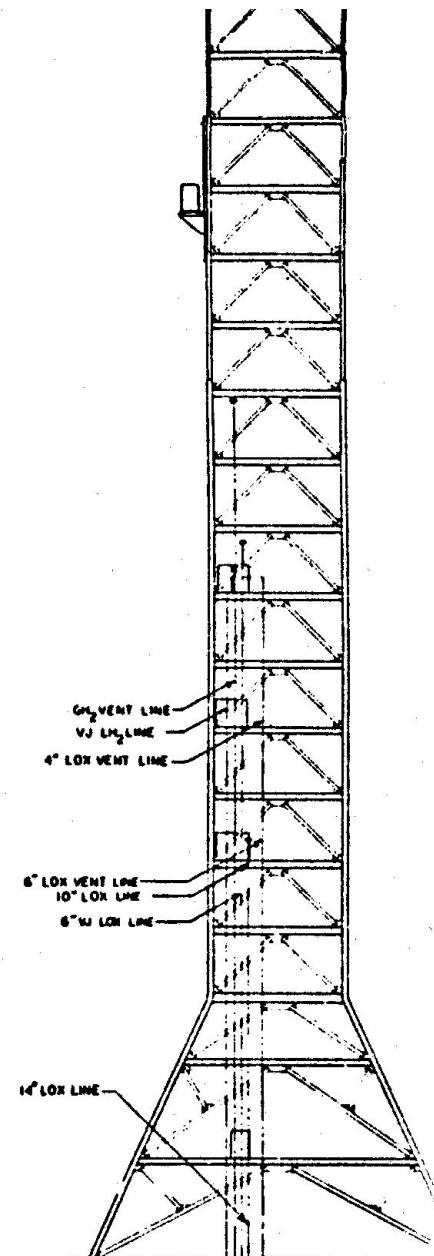

NORTH ELEVATION
 SIDE (3)
 SCALE: 1/200