

Off-Center Fed Dipoles

Practical Applications



Why?

- Looking for solutions for low band antennas
- Was abused by a counterpoise as a child
- Looking for multiband solutions
- Traditional low band wire arrays use dipoles or inverted vees
- Applications to driven & parasitic arrays

Off Center Fed Dipole Basics

- Half wave resonant antenna at lowest frequency of operation
- Even Harmonic resonances
(*V/I ratio is approximately constant*)
 - 160M: 160, 80, 40, 20, 17, 12, 10
 - 80M: 80, 40, 20, 10
- Fed 1/3 of the way from the end vs. in the middle
- Feed point impedance is approximately 200Ω
 - 4:1 current balun does the trick

OCFD Data

- 80M
 - Used for 10 years
 - 136 feet in length (located at abt 30 feet)
 - Fed 44.5 feet from one end
 - Resonant on 80M, 40M, 20M, 10M (no tuner)
- 160M (measured data)
 - Recent addition
 - 264 feet long (located at abt 80 feet)
 - Fed 88 feet from one end; 4:1 homebrew balun
 - 200 Ω on 160M and 166 Ω on 80M at resonance
 - 2:1 BW: >200 kHz on 160M, 260 kHz on 80M

Why They Work

- It's just a dipole!
- But
 - $\frac{1}{2}$ wave resonant element, then harmonic wire
 - Voltage/Current relationship at $\frac{1}{3}$ feed point provides essentially constant ratio on even harmonics
 - Broadside null on harmonics

Current Distribution on a Dipole

Current & Voltage at Fundamental

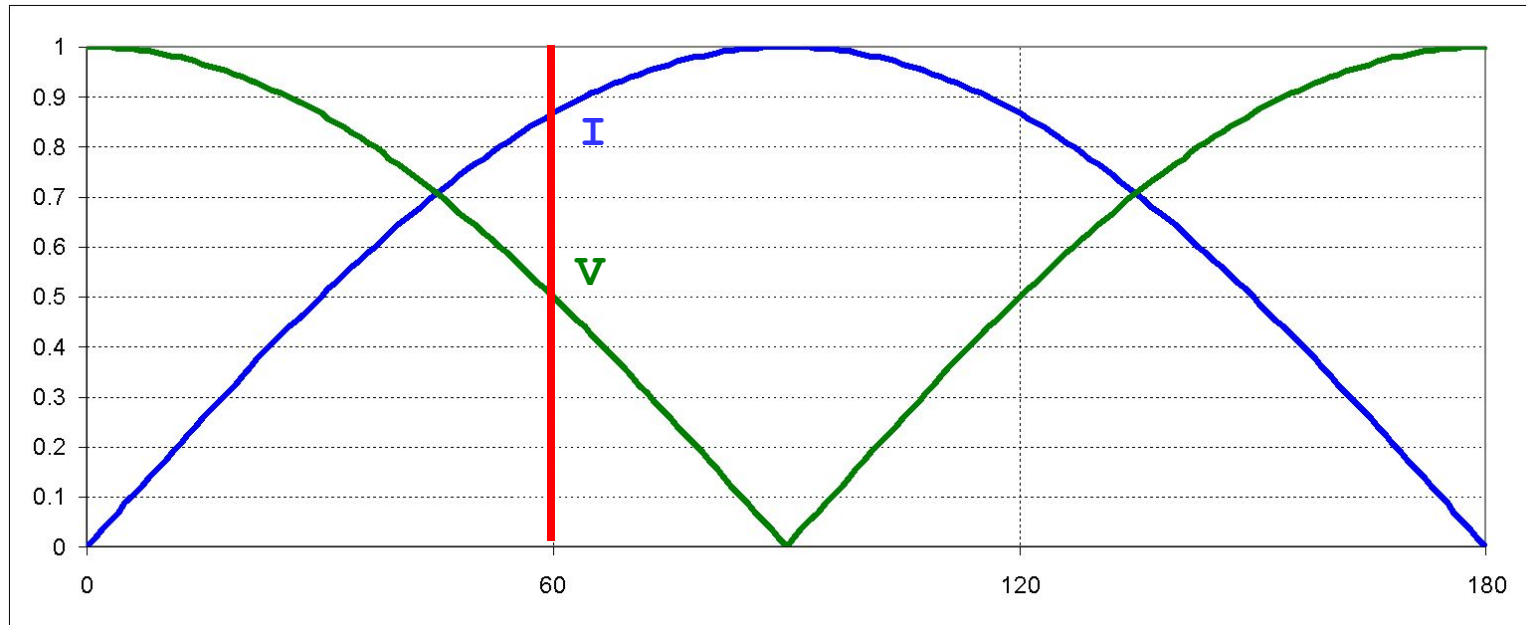

I & V at 2nd Harmonic

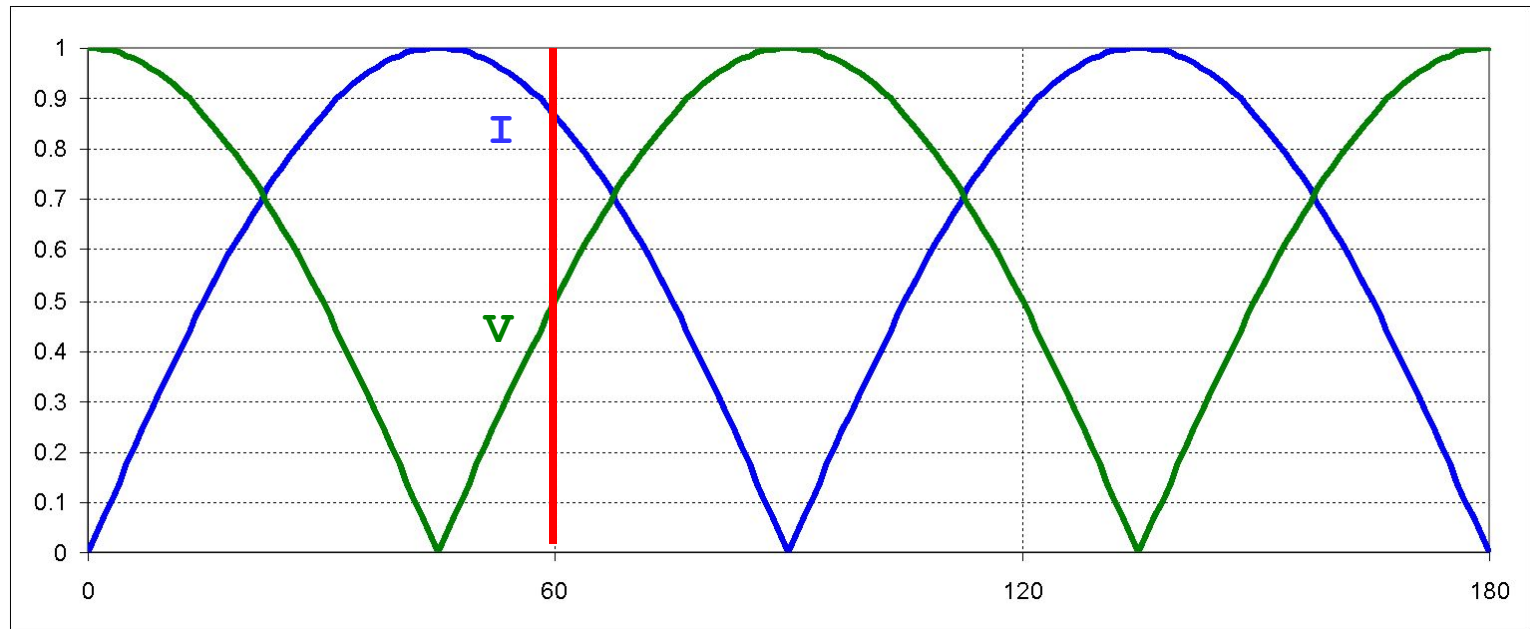

I & V at 4th Harmonic

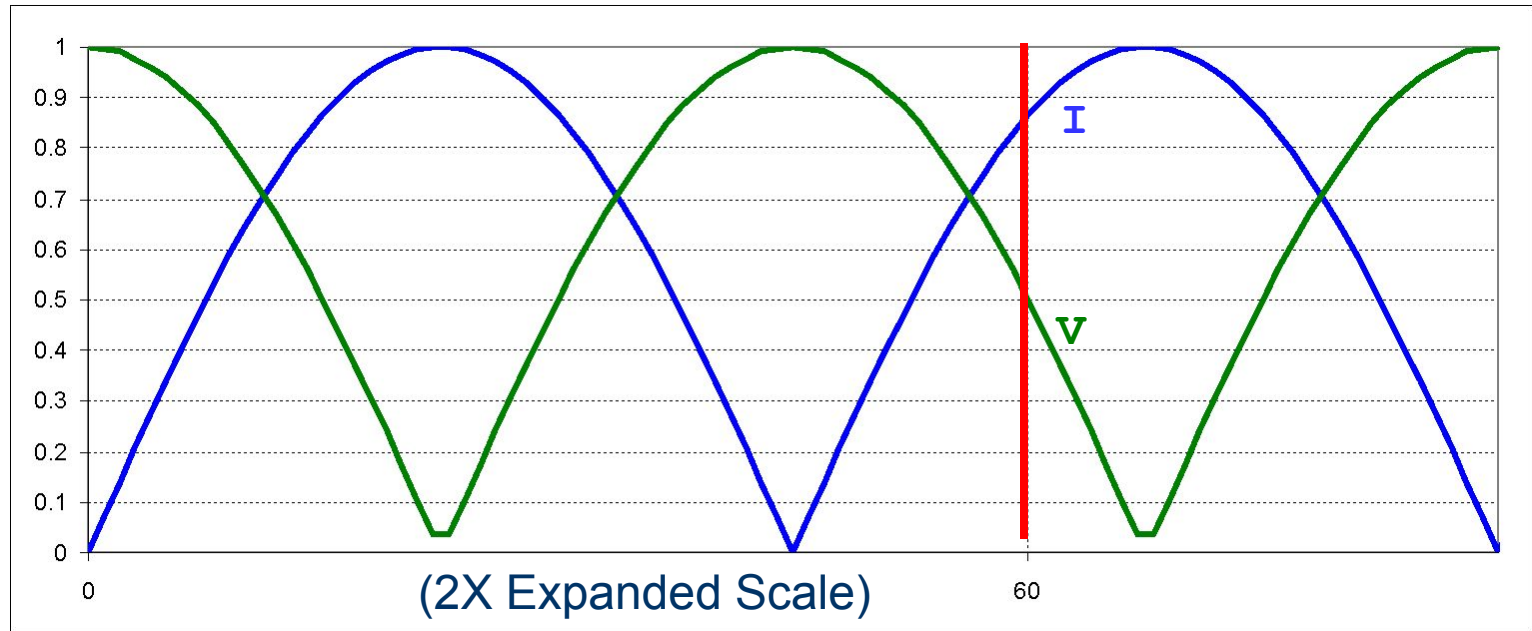

I & V at 8th Harmonic

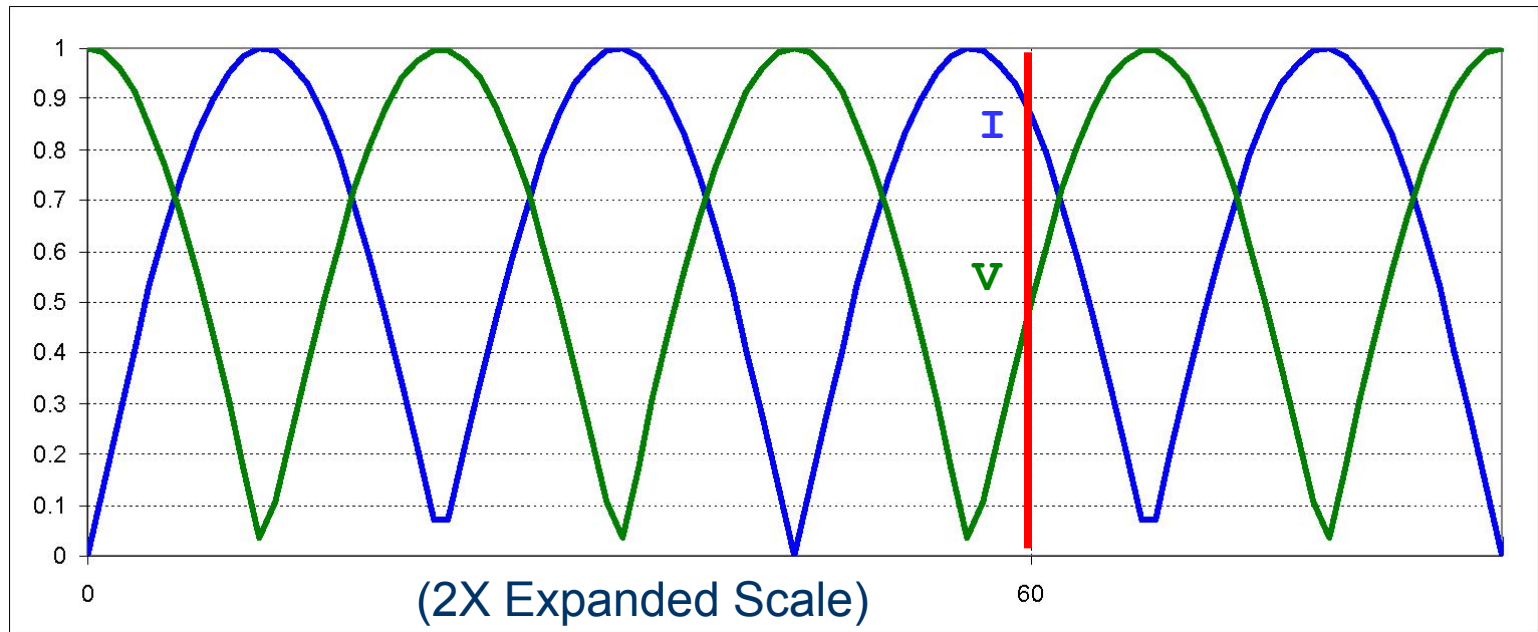

But what about the 6th harmonic?

- Feed point is at a current minimum
- Very high impedance

I & V at 6th Harmonic (Bad Dog!)

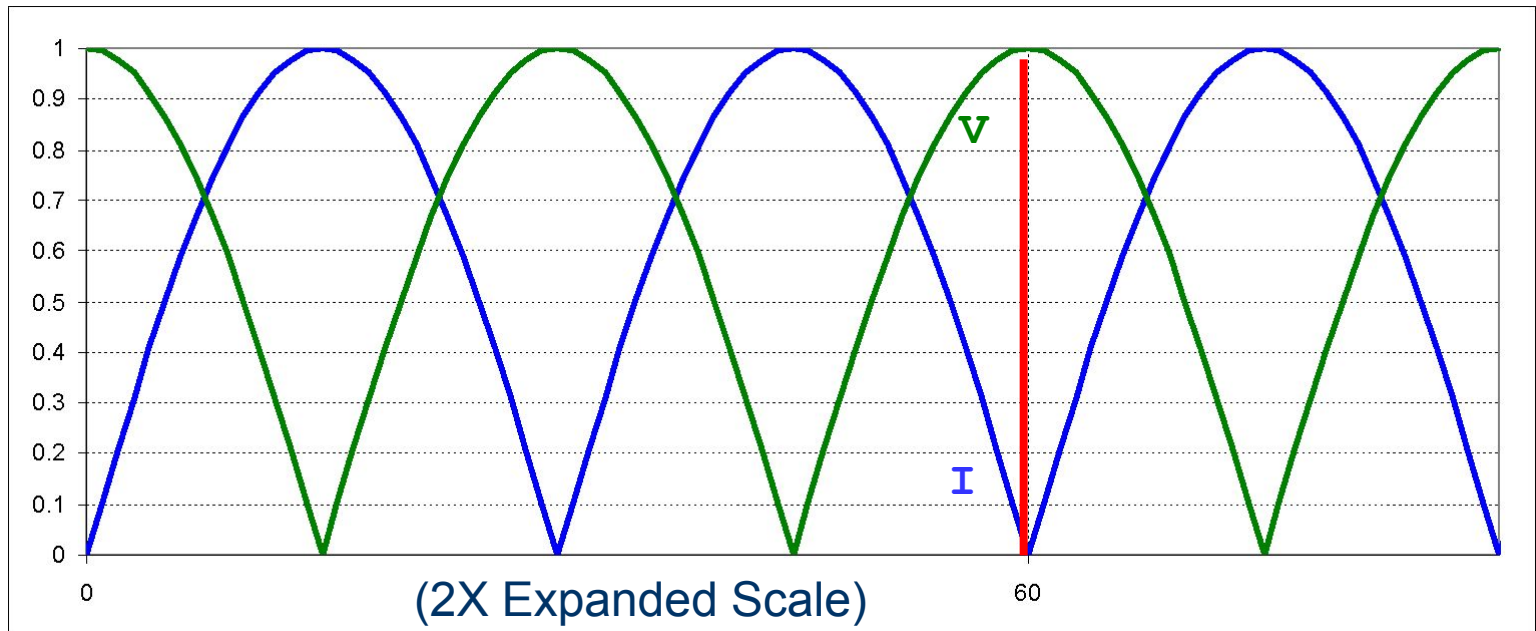

And Odd Harmonics?

- Same problem: Current minimum

I & V at 3rd Harmonic (Bad Dog!)

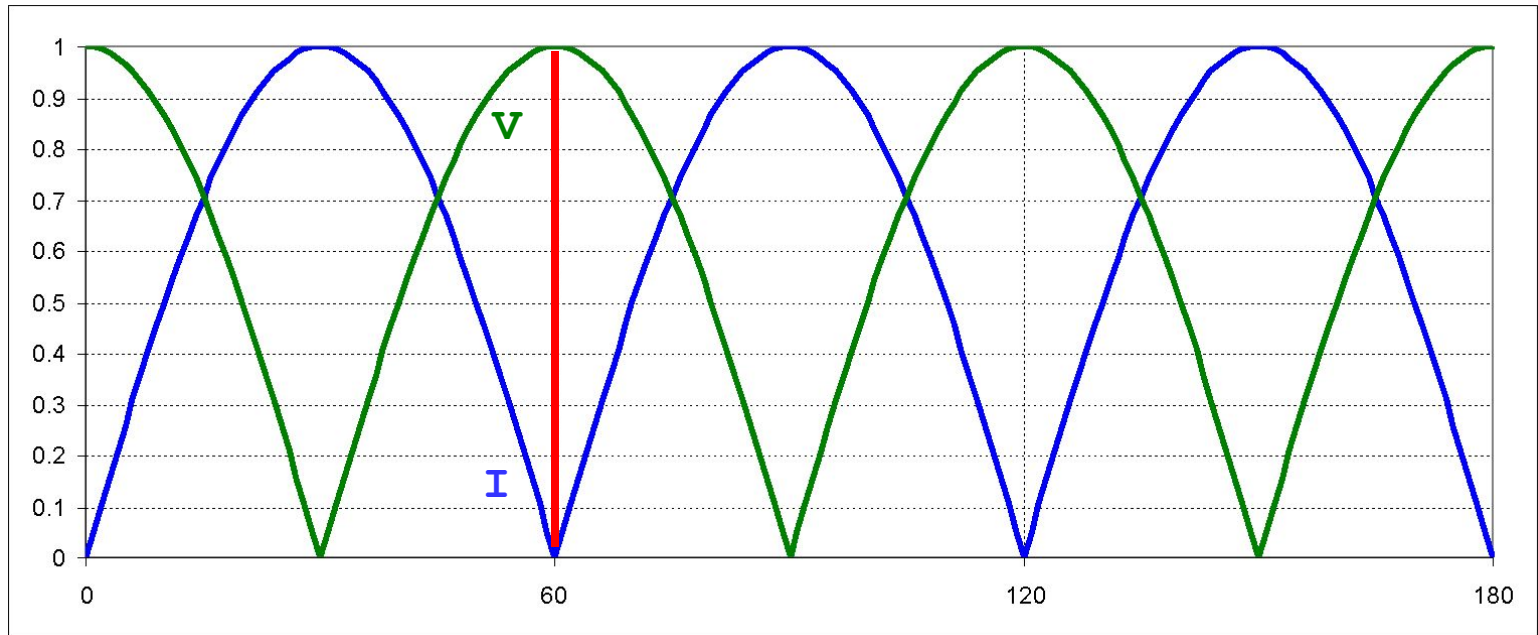

Basic Gain Plots

160M center fed dipole at 80 feet

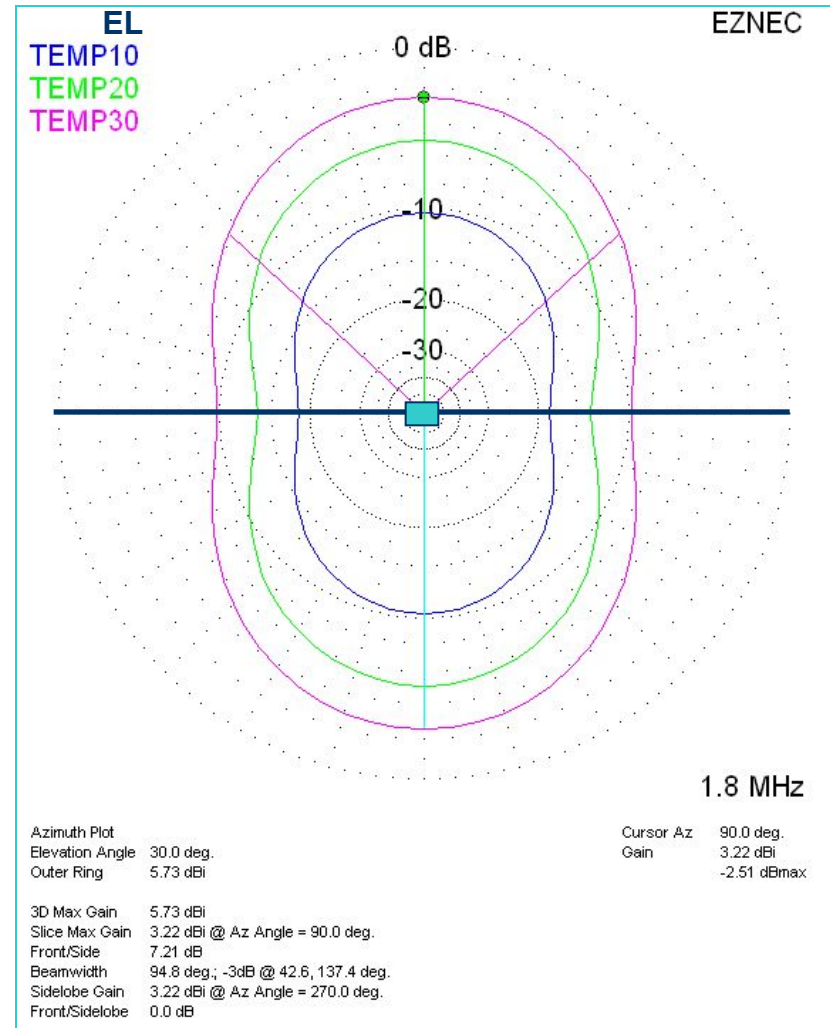
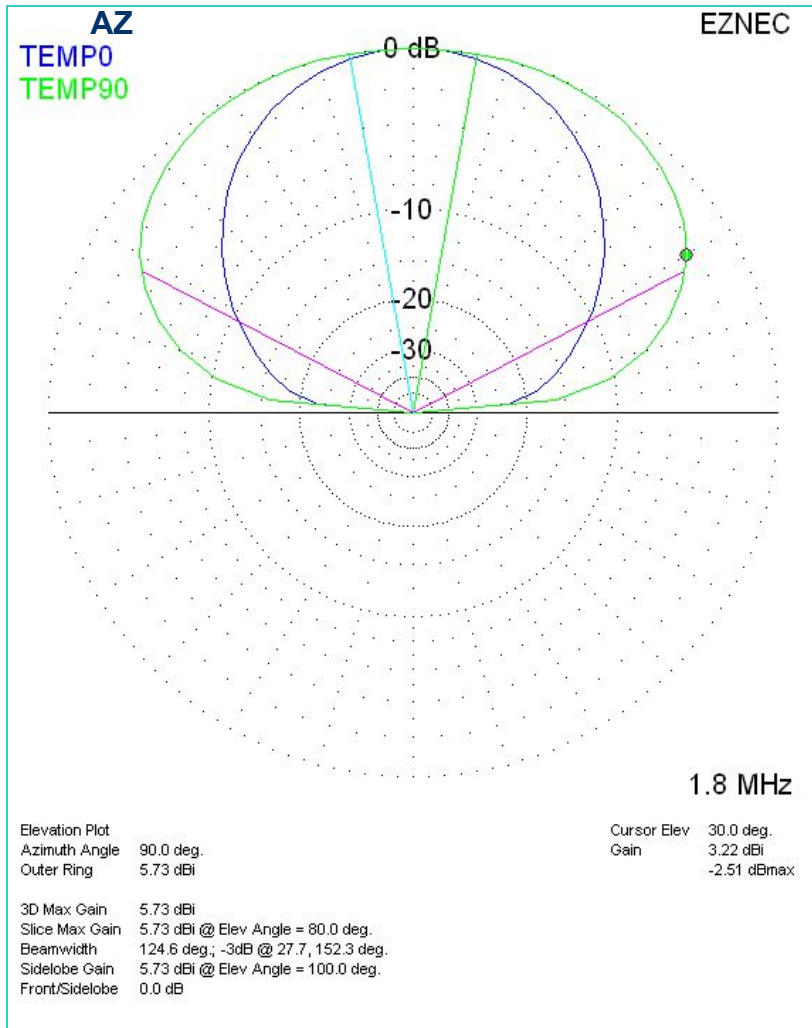

N1IW

160M OCFD at 80 feet

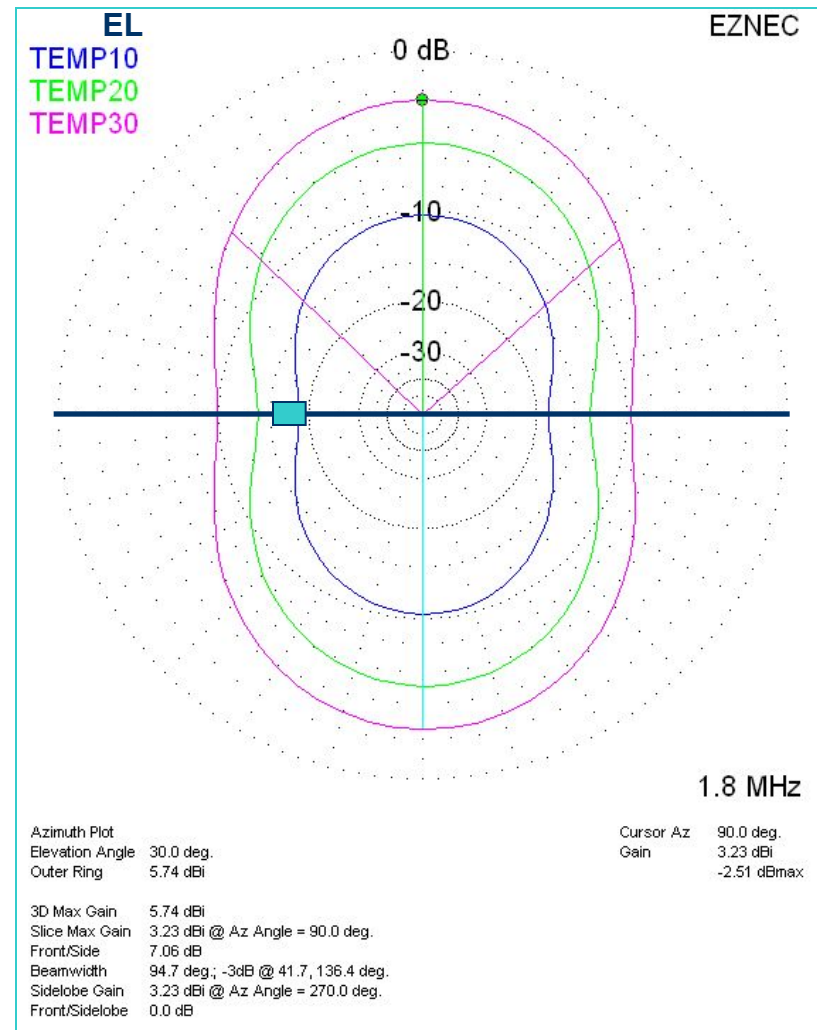
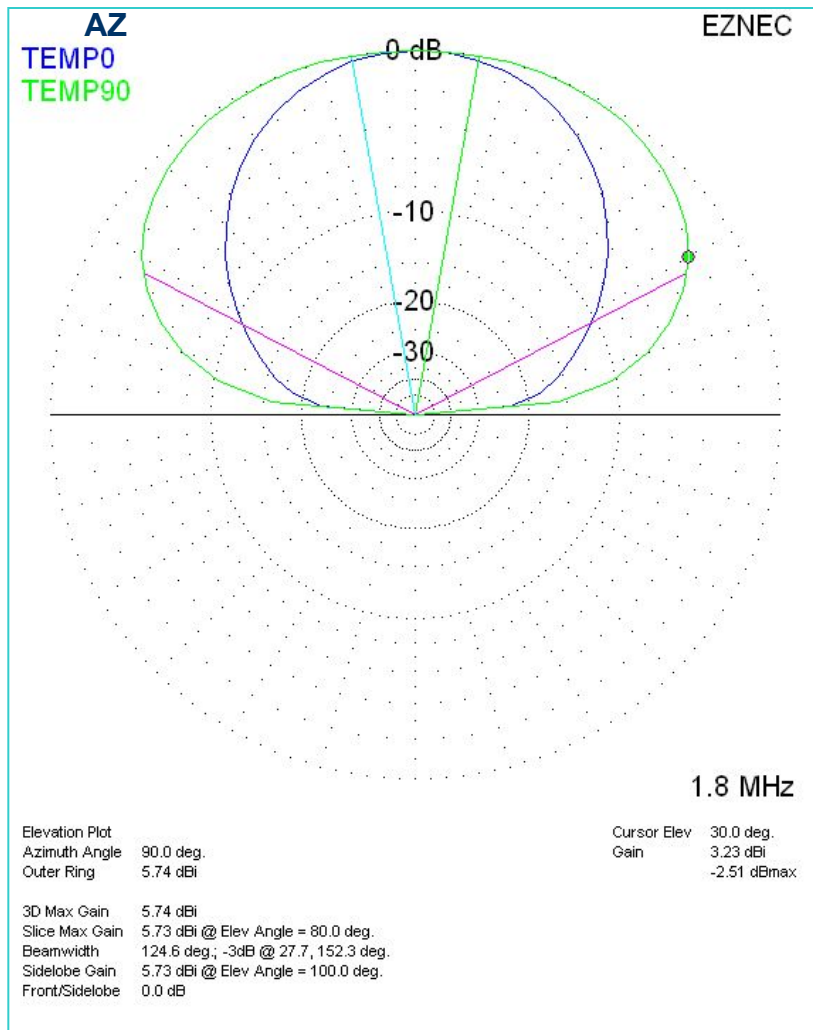

N1IW

160M OCFD on 80M (x2)

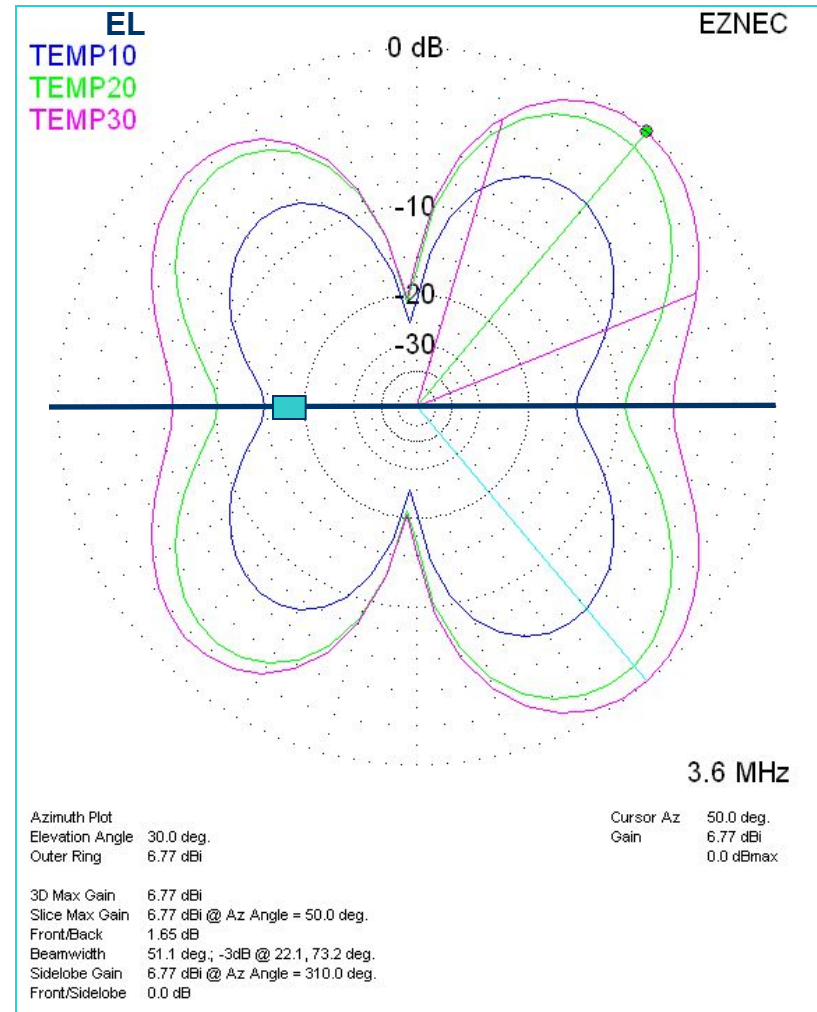
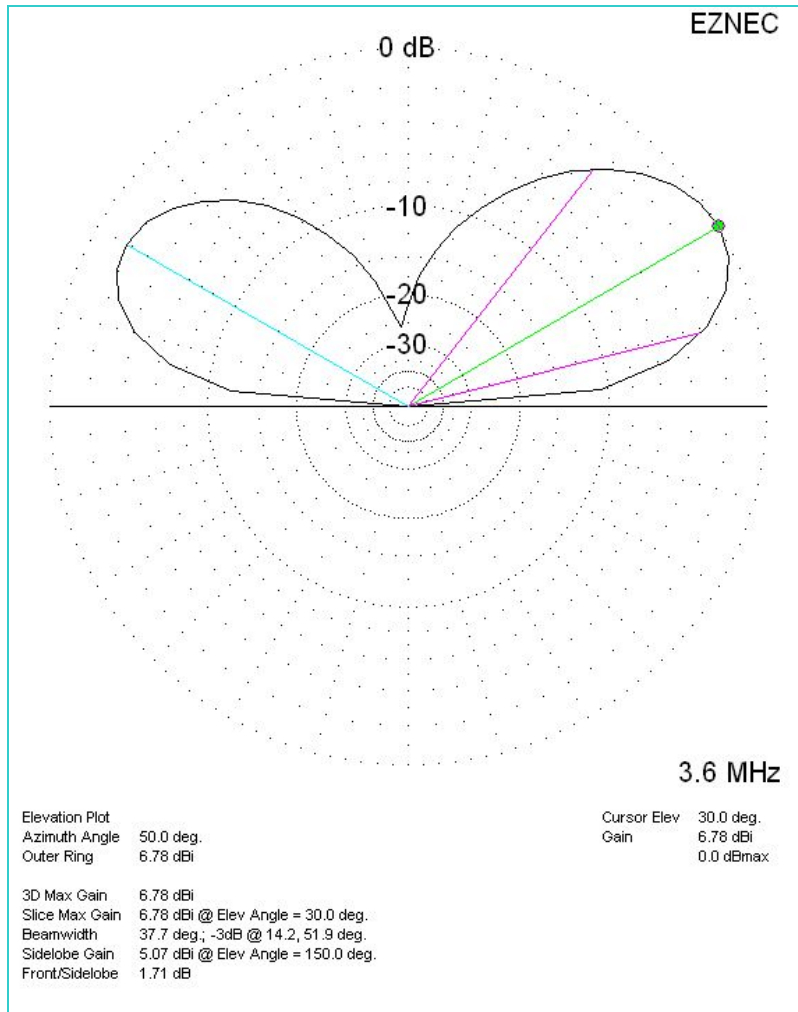

N1IW

160M OCFD on 40M (x4)

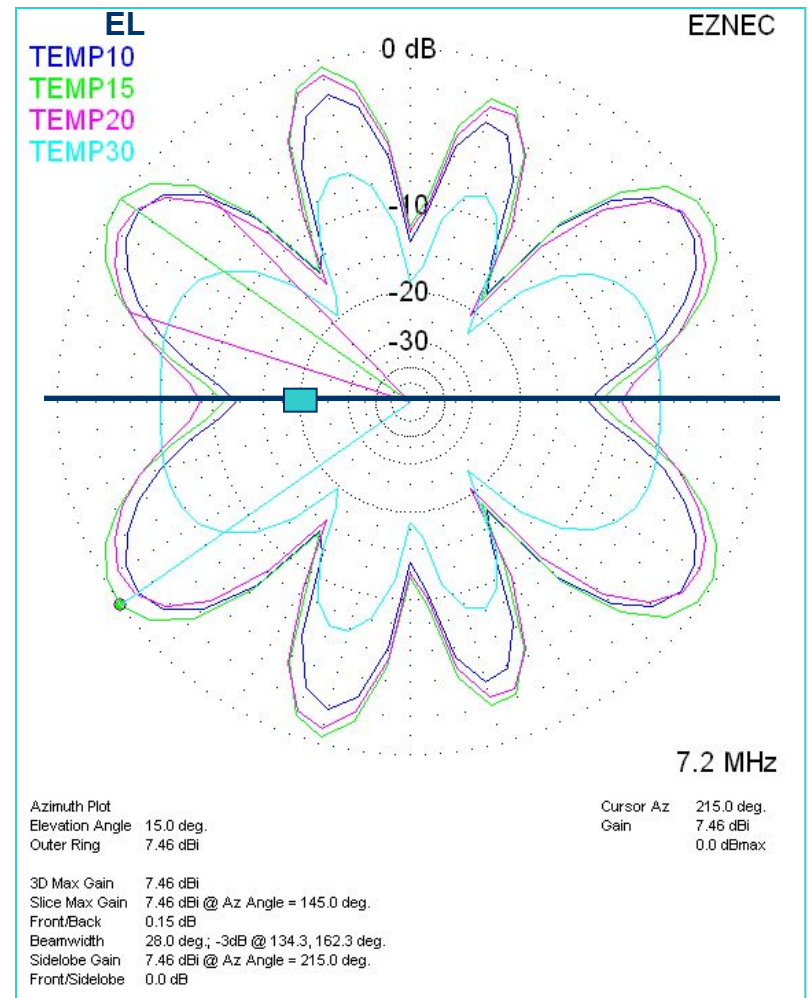
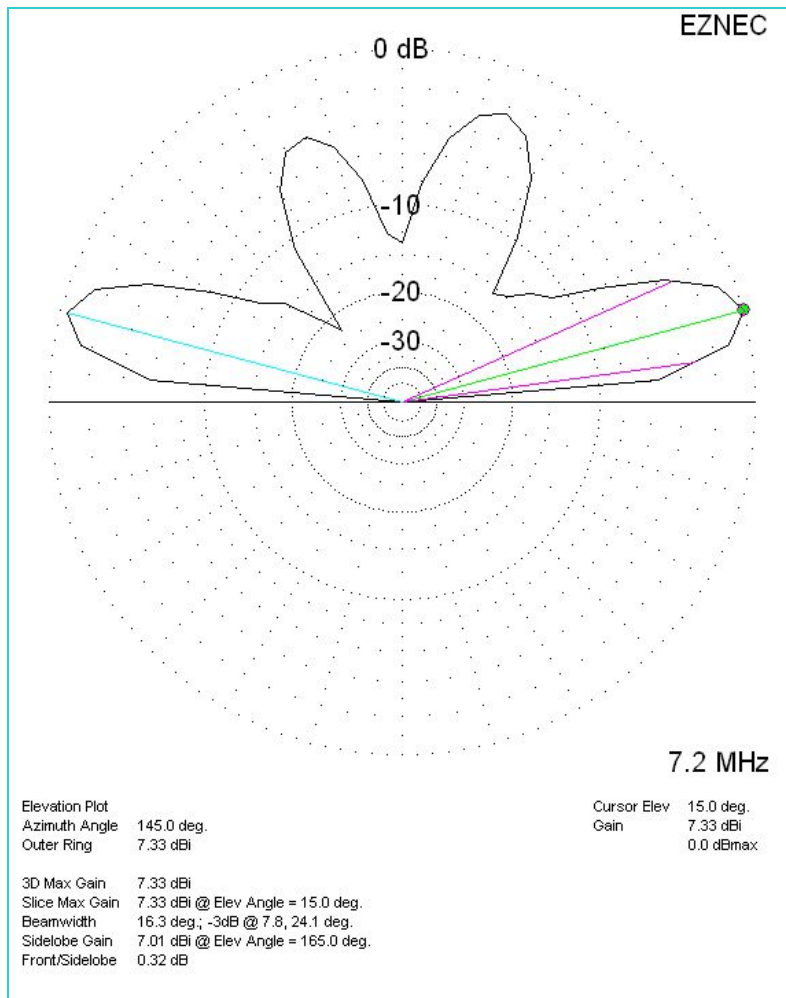

N1IW

160M OCFD on 20M (x8)

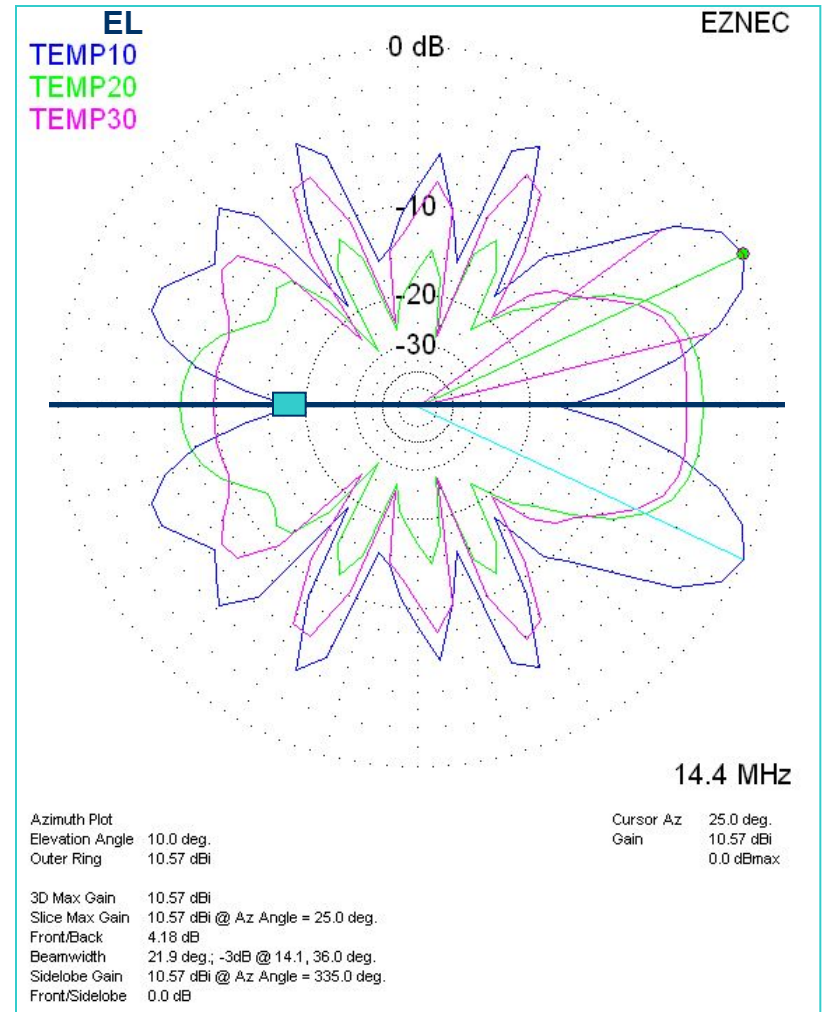
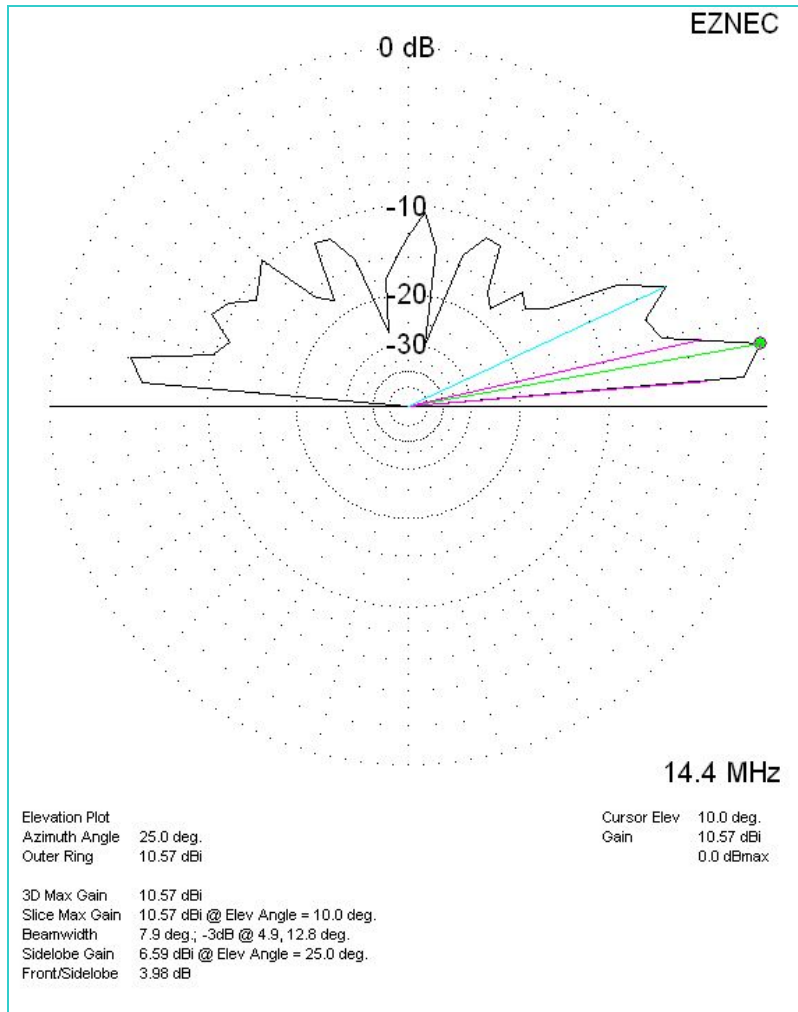

N1IW

160M OCFD on 10M (x16)

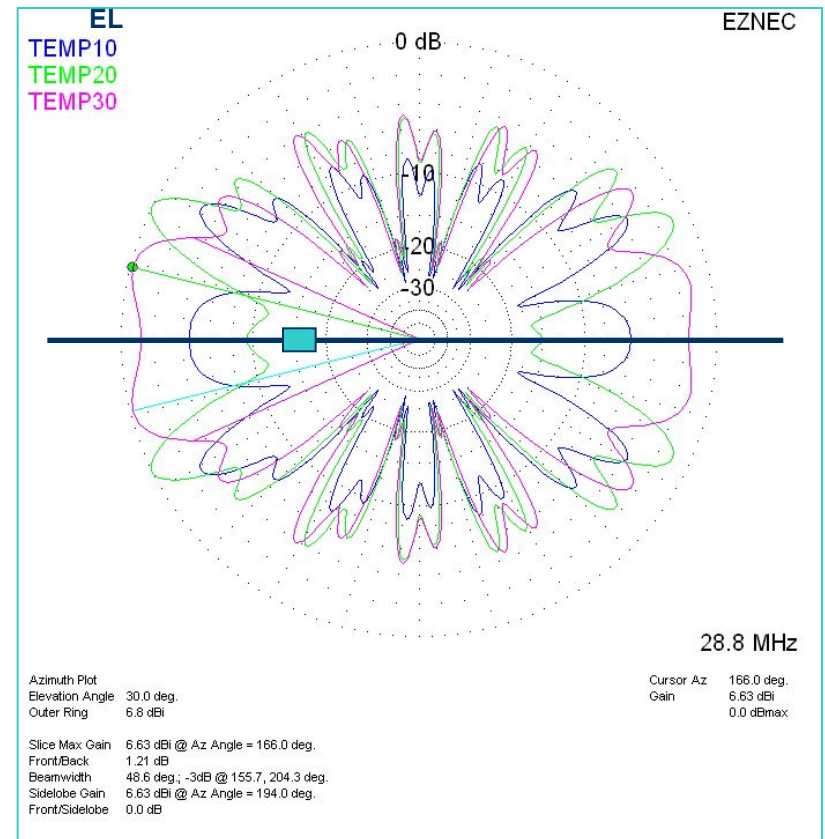
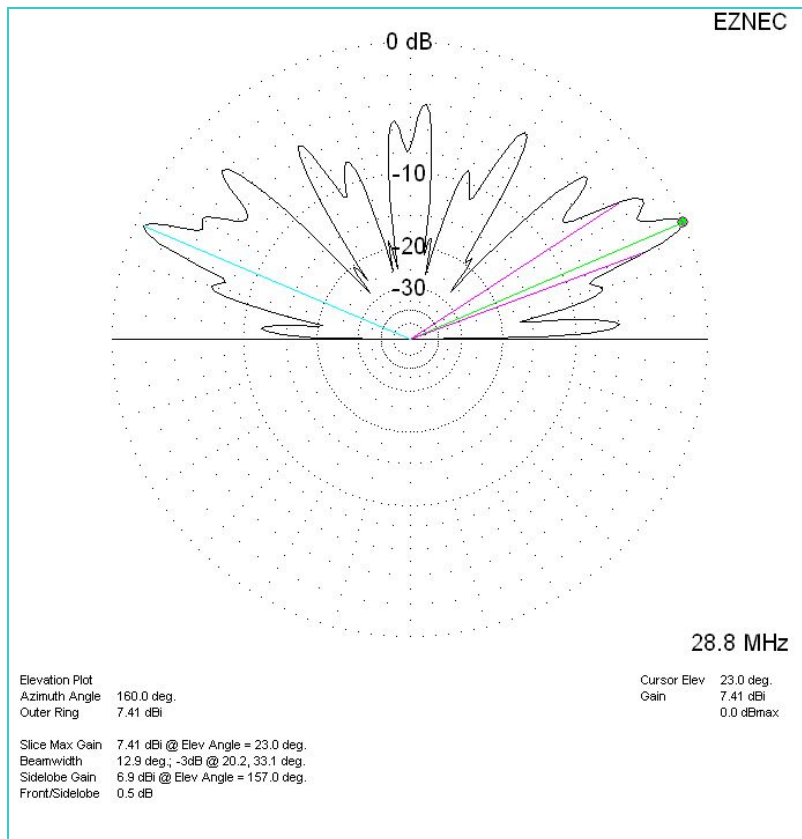

N1IW

Geometry/Height

- Old 80M design: 45.3 ft, 90.7 ft; 30 ft high
- New 160M design: 88ft, 176 ft; 80 ft high
- Both use 4:1 Guanella balun design
 - 80M variation: 45/65 ft flat+26 ft dropper
- Feed point impedance at resonance drops as effective height above ground decreases
 - Recommend $1/3 \lambda$ up for 4:1 balun to work well

4:1 Guanella Current Balun

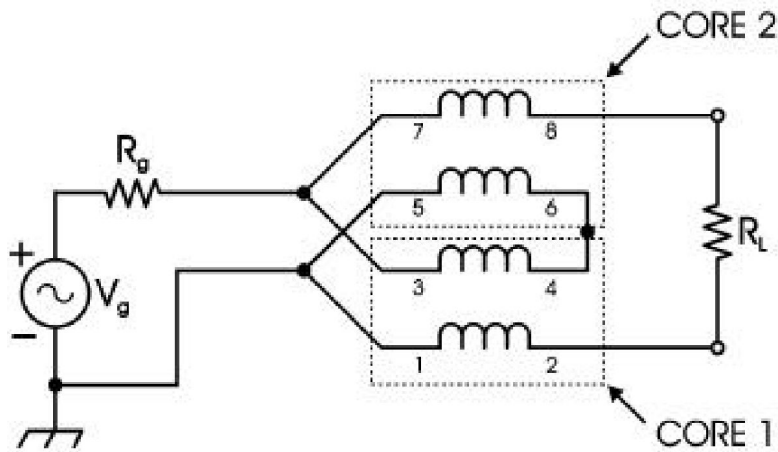

80M OCFD Construction Detail

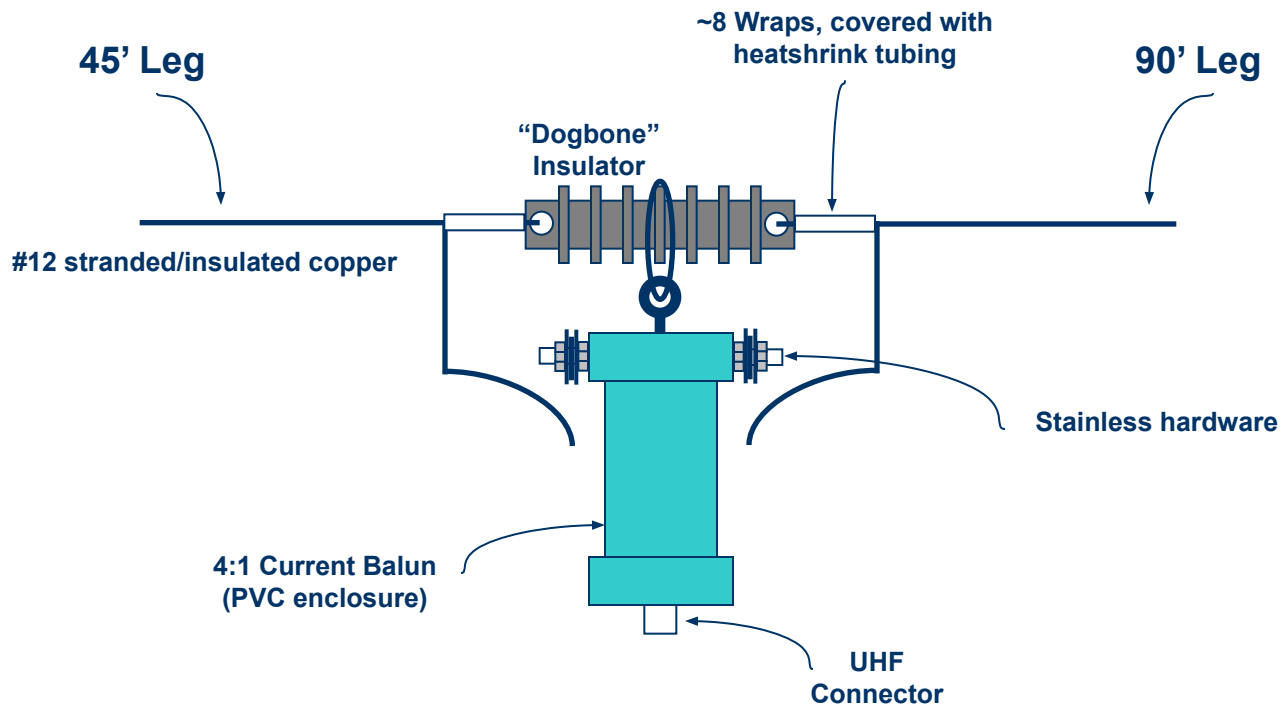

160M OCFD Construction Detail

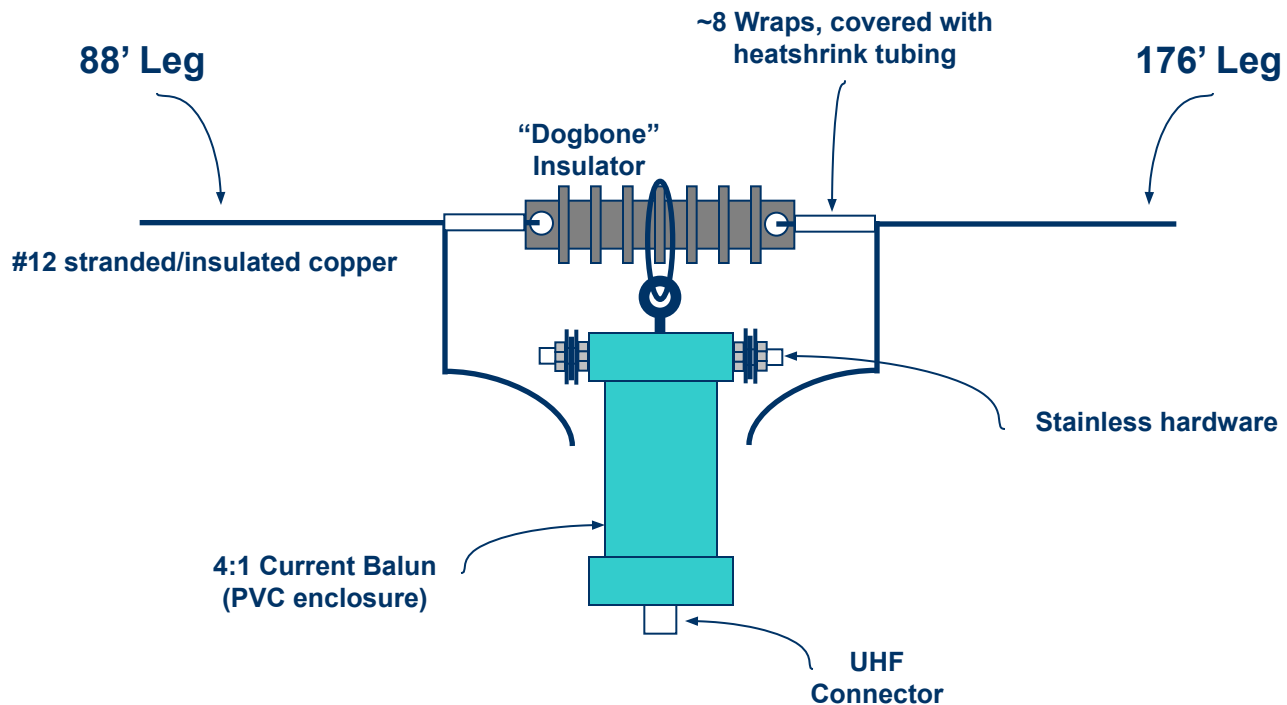

160M OCFD Normalized VSWR Plots

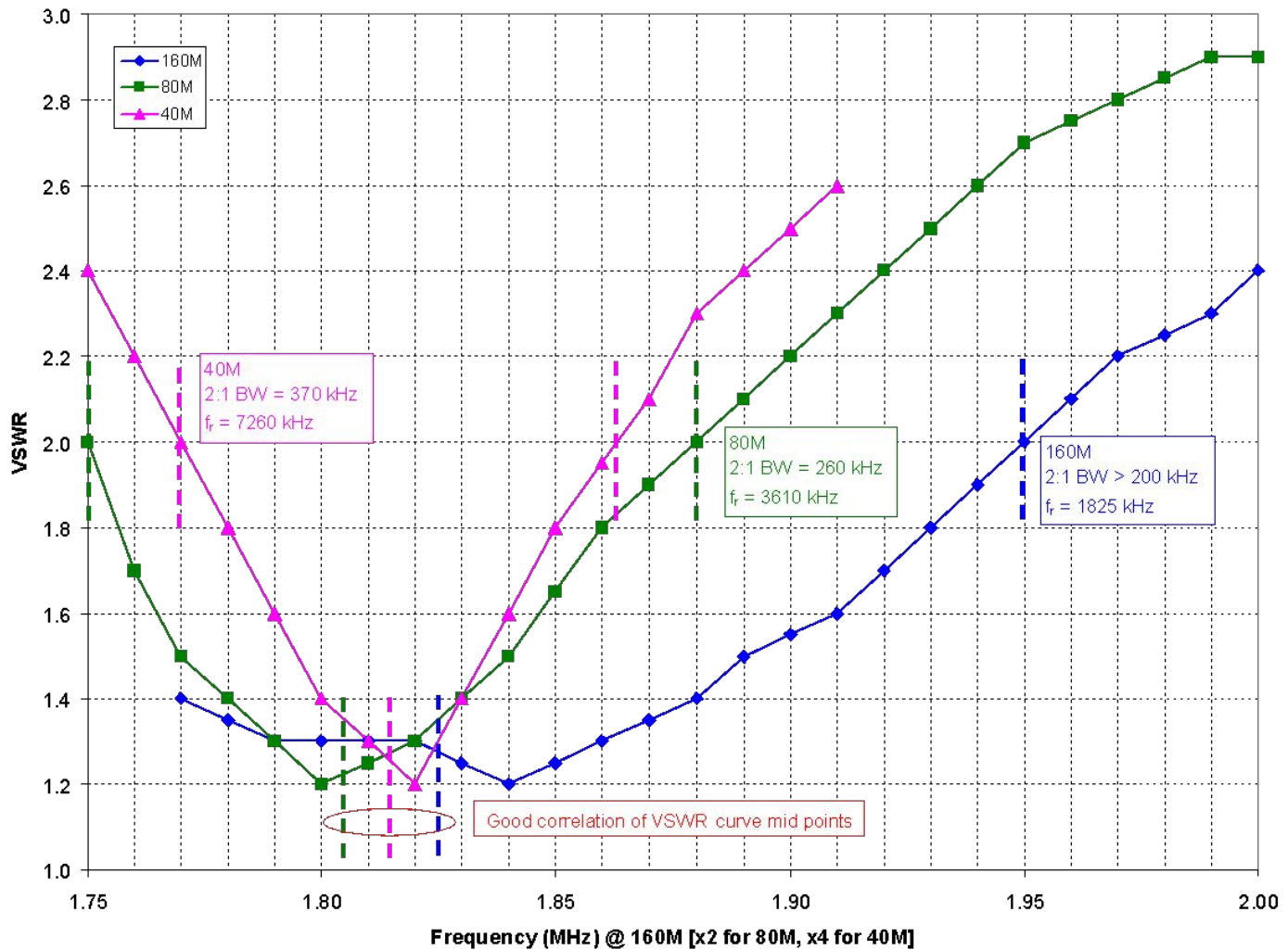

OCFD Orientation Issues

Single 160M OCFD at 125°, 160M/80M

- How to deal with the broadside null...
- Rotate antenna to achieve best gain compromise

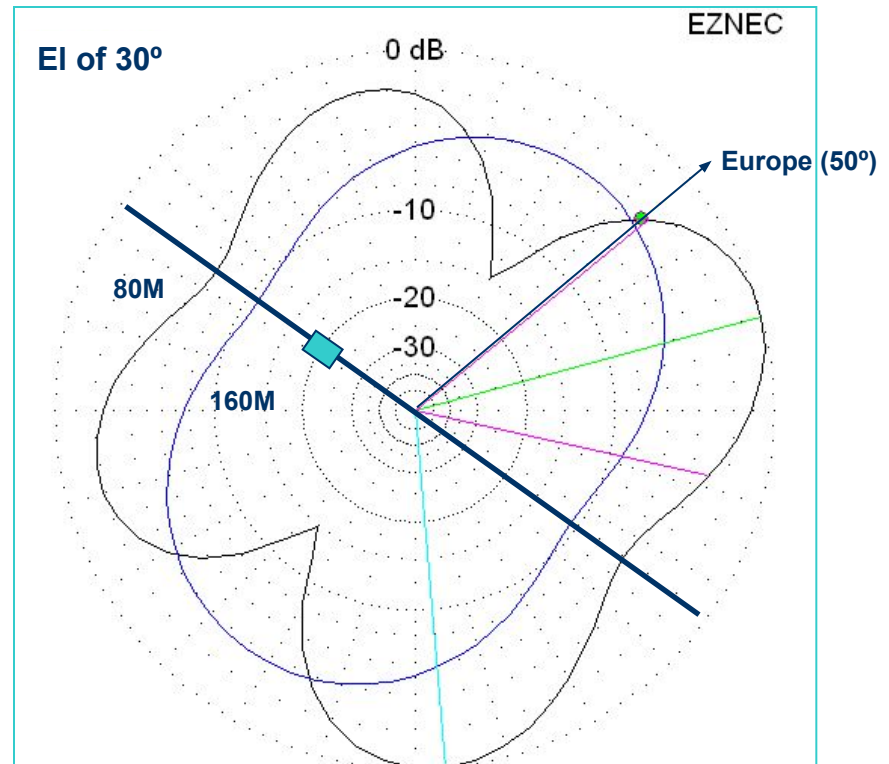

N1IW

Disclaimer...

- Your mileage may vary
- Batteries not included
- Some assembly required
- Professional driver, closed course
- Void where prohibited
- Do not dispose of in fire
- Taxes, titles, license fees extra
- 10M band openings longer than 2 hours require immediate medical attention