

POWERMAX

AHE58 DEBUG GUIDE

CHIP RESISTOR



MARK	ALGORITHM	VALUE
100	$10*1$	$10\ \Omega$
201	$20*10$	$200\ \Omega$
1000	$100*1$	$100\ \Omega$
4701	$470*10$	$4.7\text{K}\ \Omega$
5R1	$5R1=5.1$	$5.1\ \Omega$
51R	$51R=51$	$51\ \Omega$
R220	$R220=0.22$	$0.22\ \Omega$
R150	$R150=0.15$	$0.15\ \Omega$

DIODE

Use diode range		
Red	Black	Indication
Positive	Negative	0.4~0.5
Negative	Positive	0.6~0.9

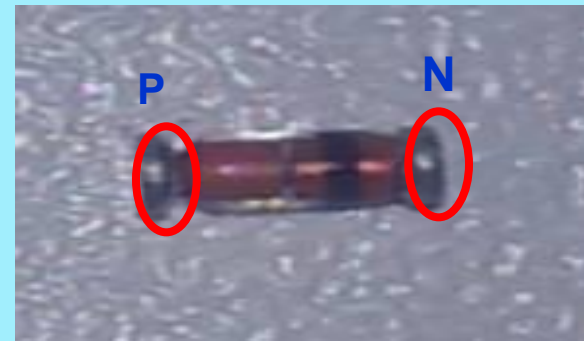

Diode bridge

Use diode range		
Red	Black	Indication
PIN 4	PIN 3	0.4~0.5
	PIN 2	0.4~0.5
	PIN 1	0.4~0.5
PIN 2	PIN 1	0.4~0.5
PIN 3		0.4~0.5

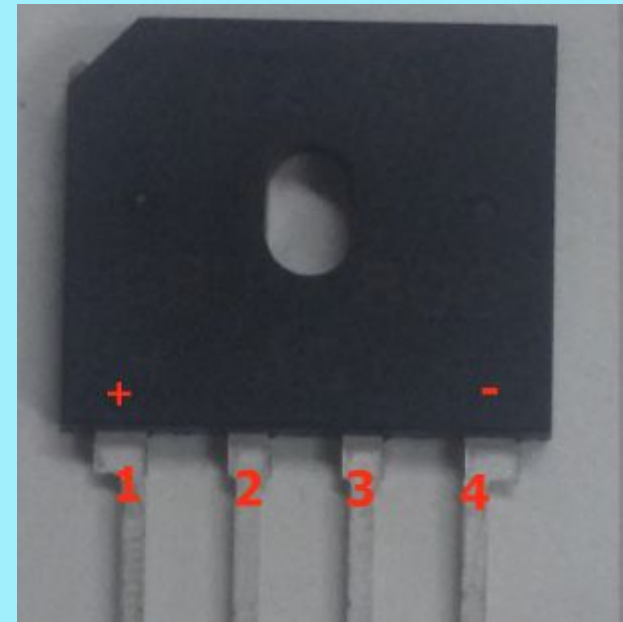

IGBT

Use diode range

Red	Black	Indication
PIN 1	PIN 2	0.4~0.5
	PIN 3	0.6~0.7



IRF530

Use diode range		
Red	Black	Indication
PIN 1	PIN 2	0.4~0.5
	PIN 3	0.6~0.9



IC (2272)

Power on, use DC range		
Red	Black	Indication
PIN 1	PIN 4	1.25V or 1.65V
PIN 7		1.25V or 1.65V
PIN 8		3.3V or 5V

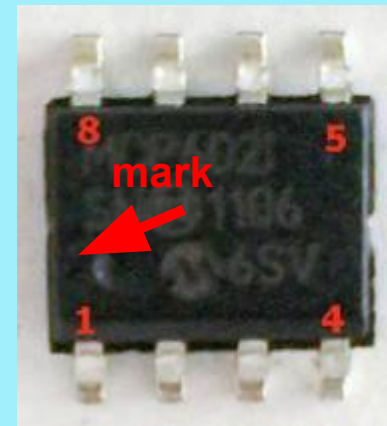

A5 series diagram block

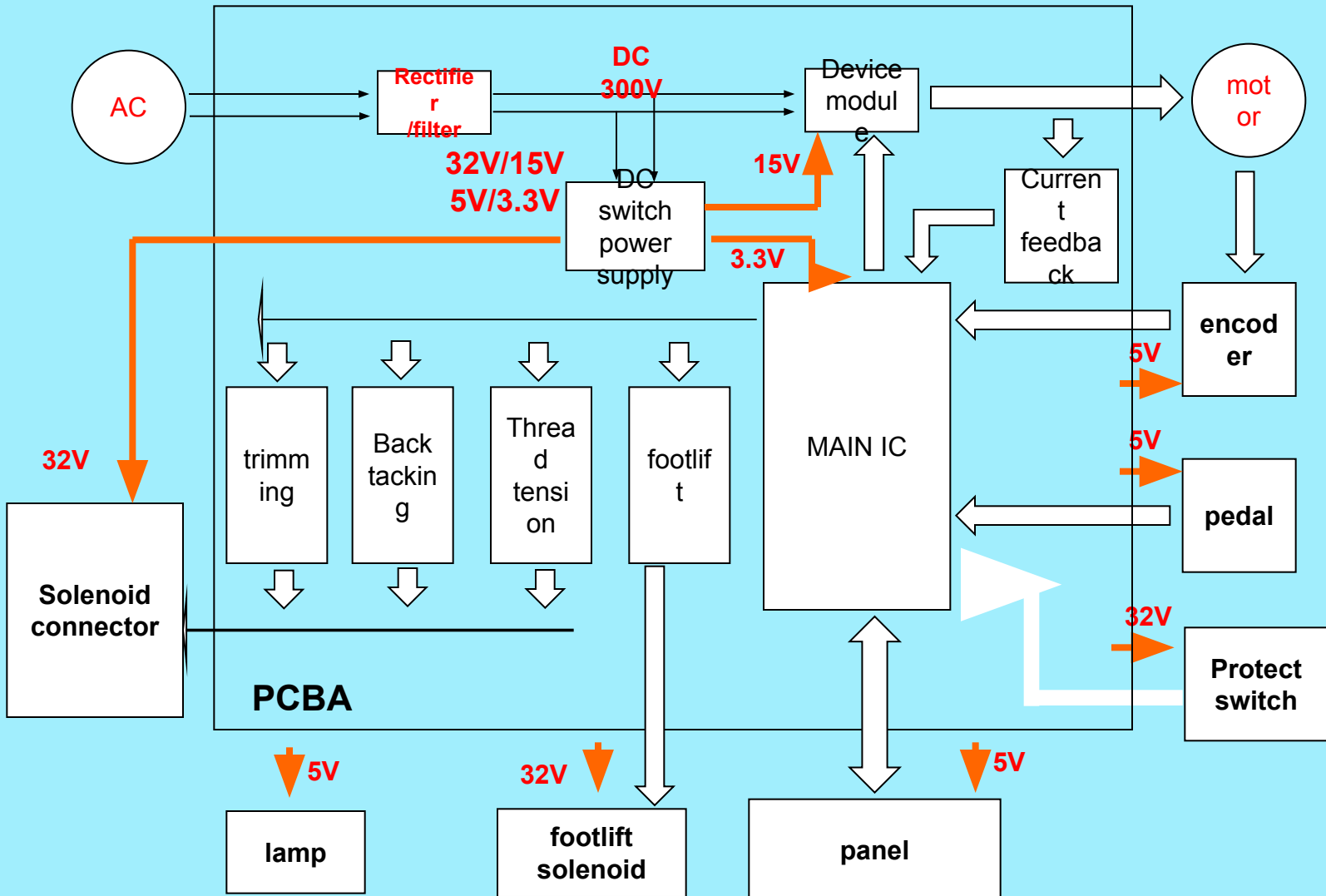

AHE58

POWER SUPPLY BLOCK

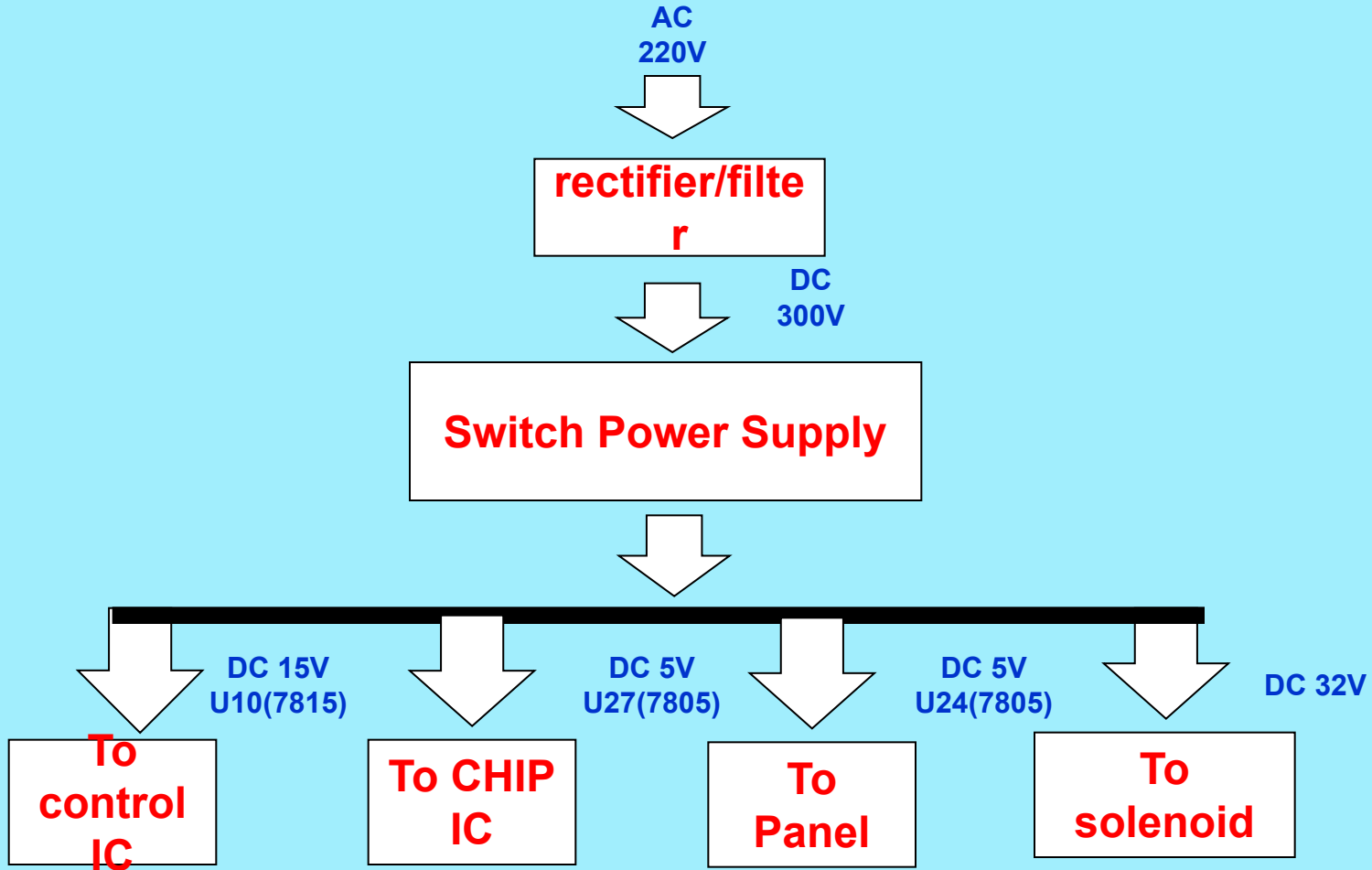

Device Module Block

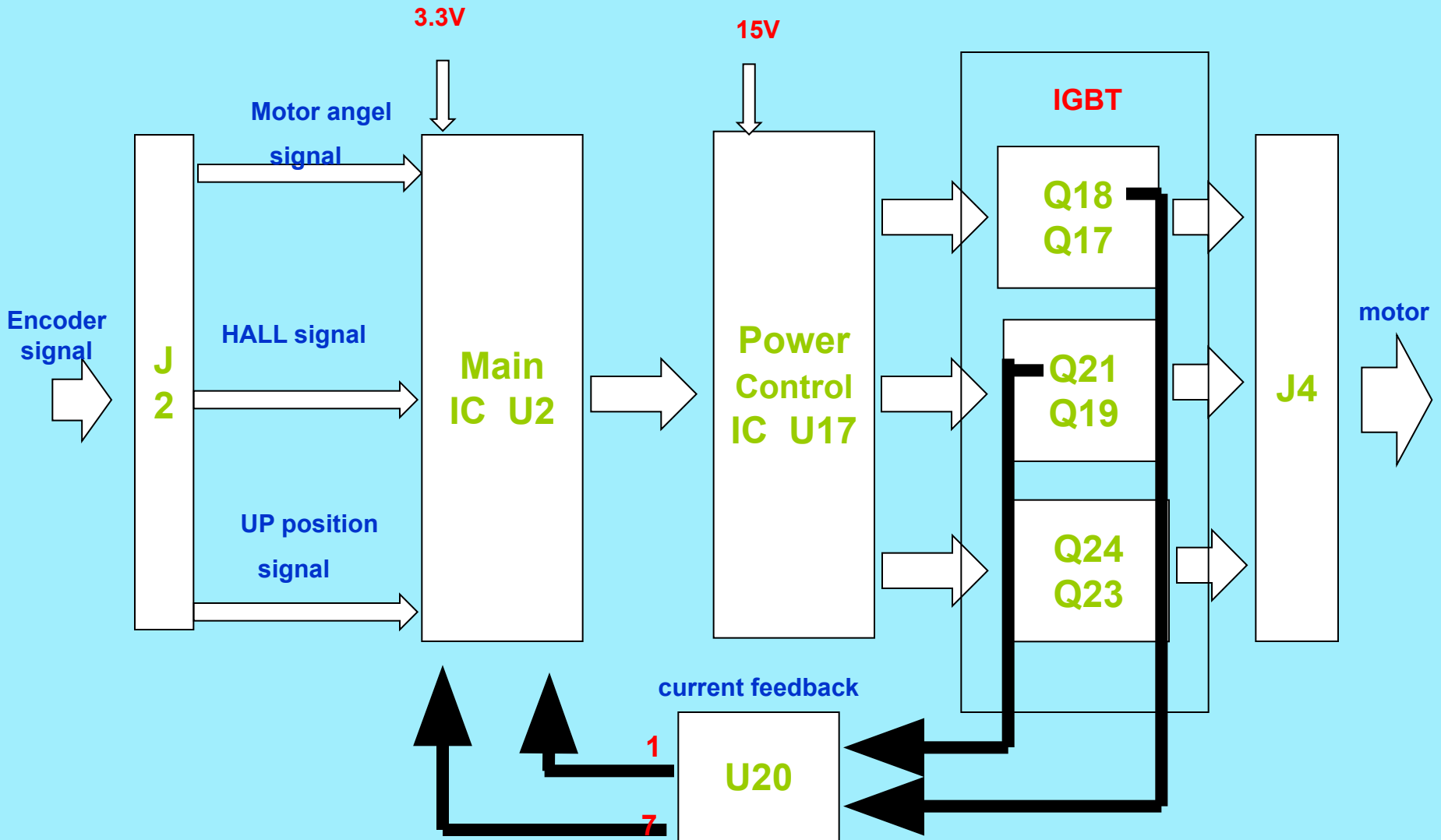

SOLENOID CIRCUIT

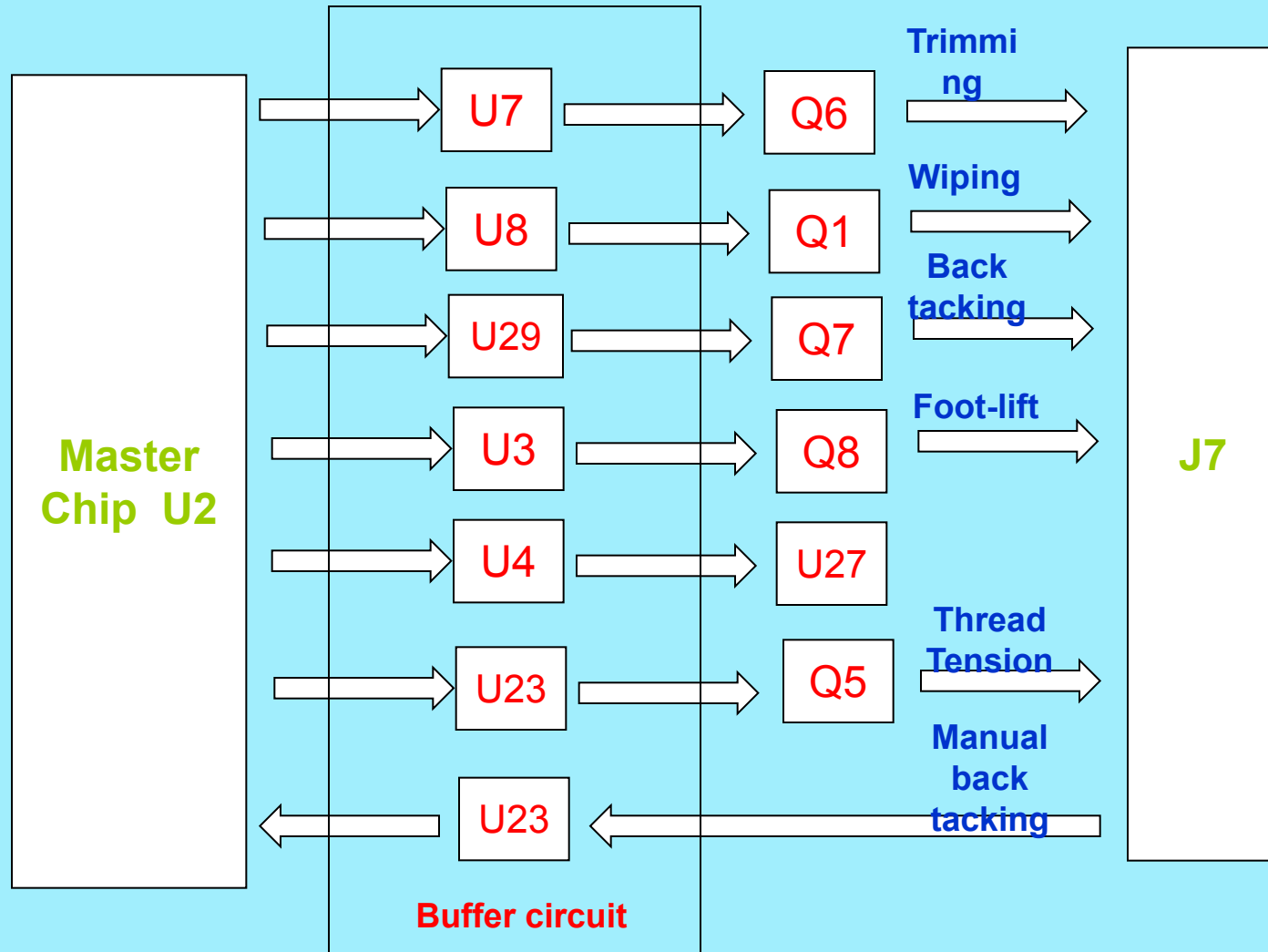

POWER BOARD

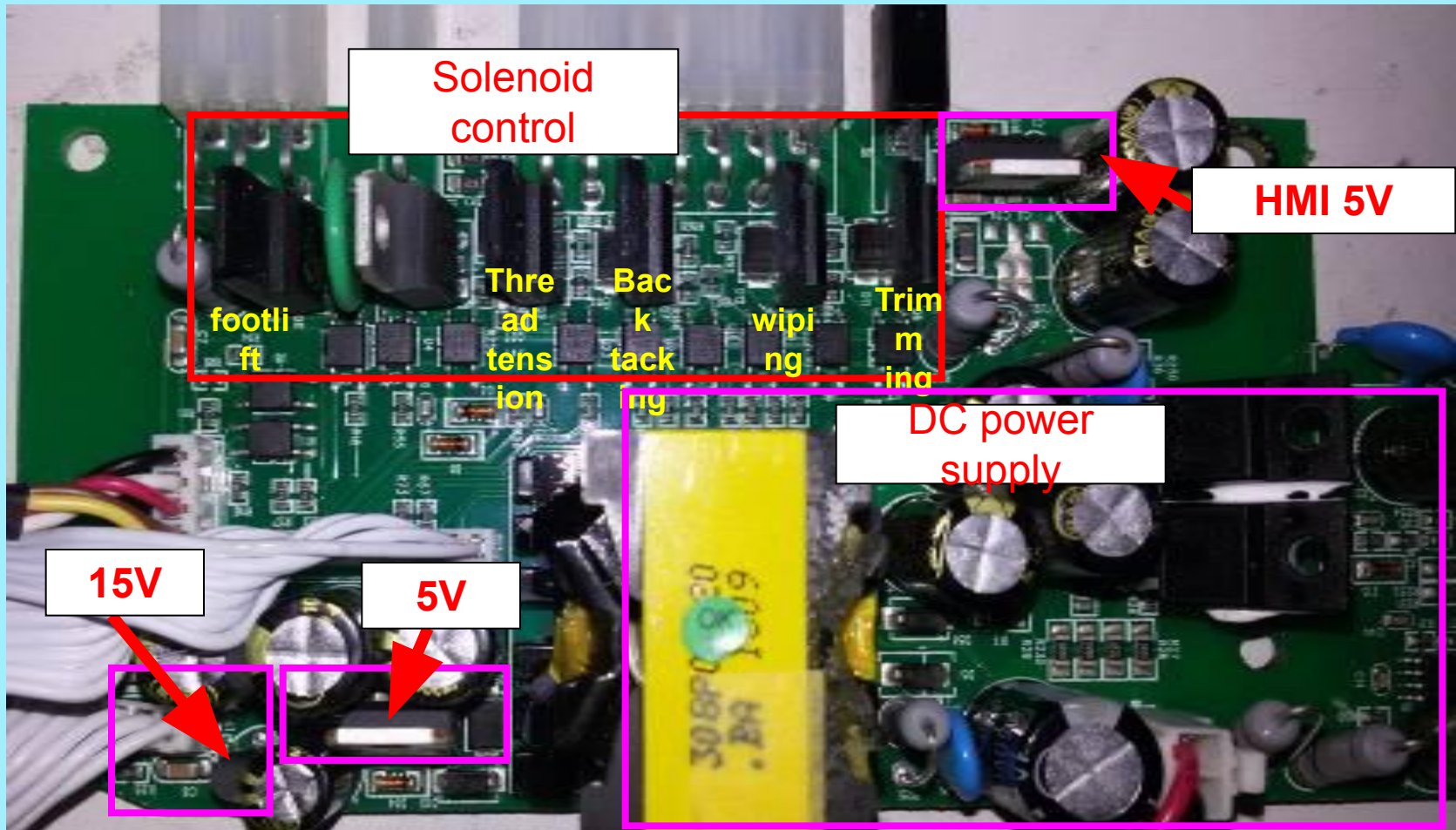

Control Board

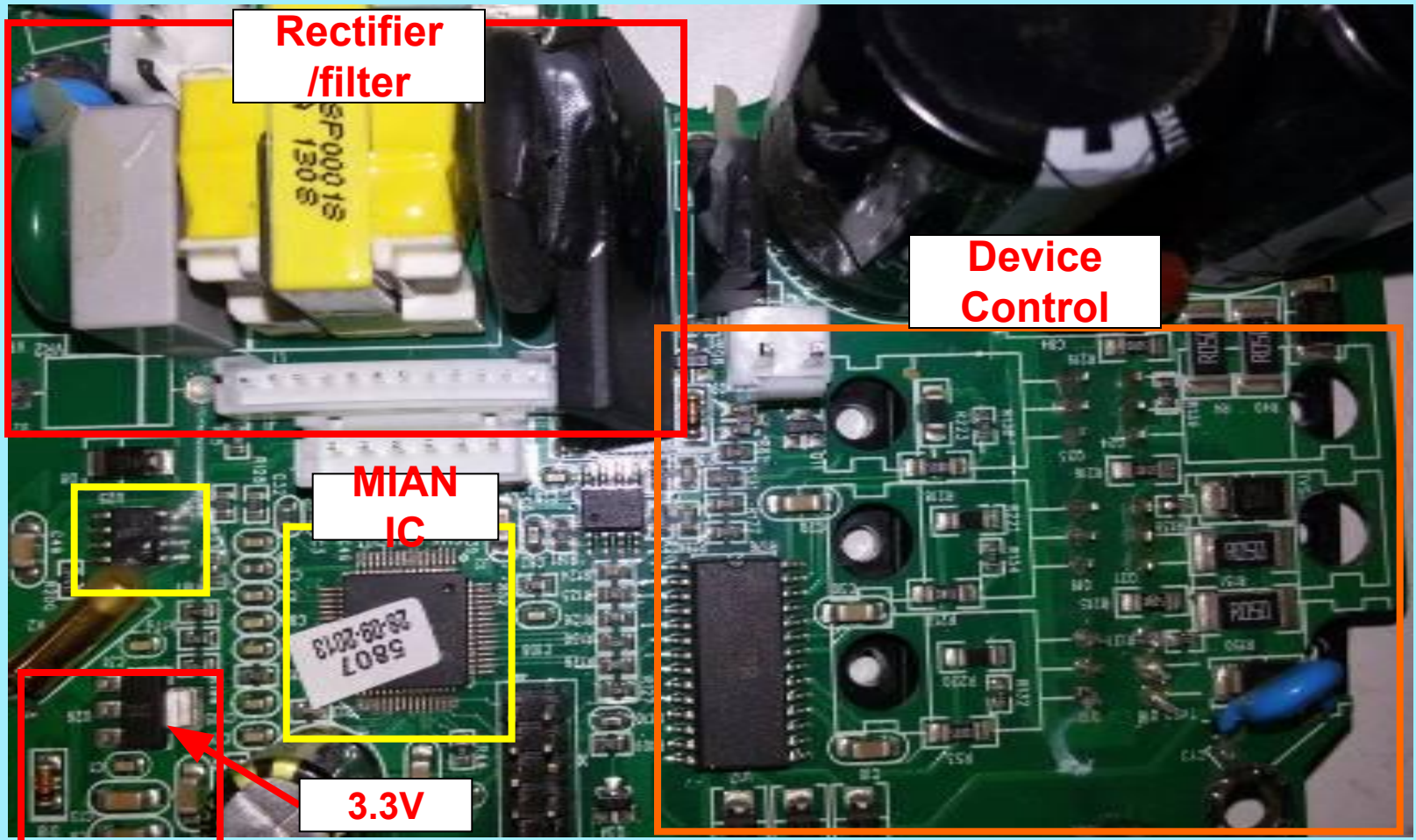

Power Board



Control Board



Err-01

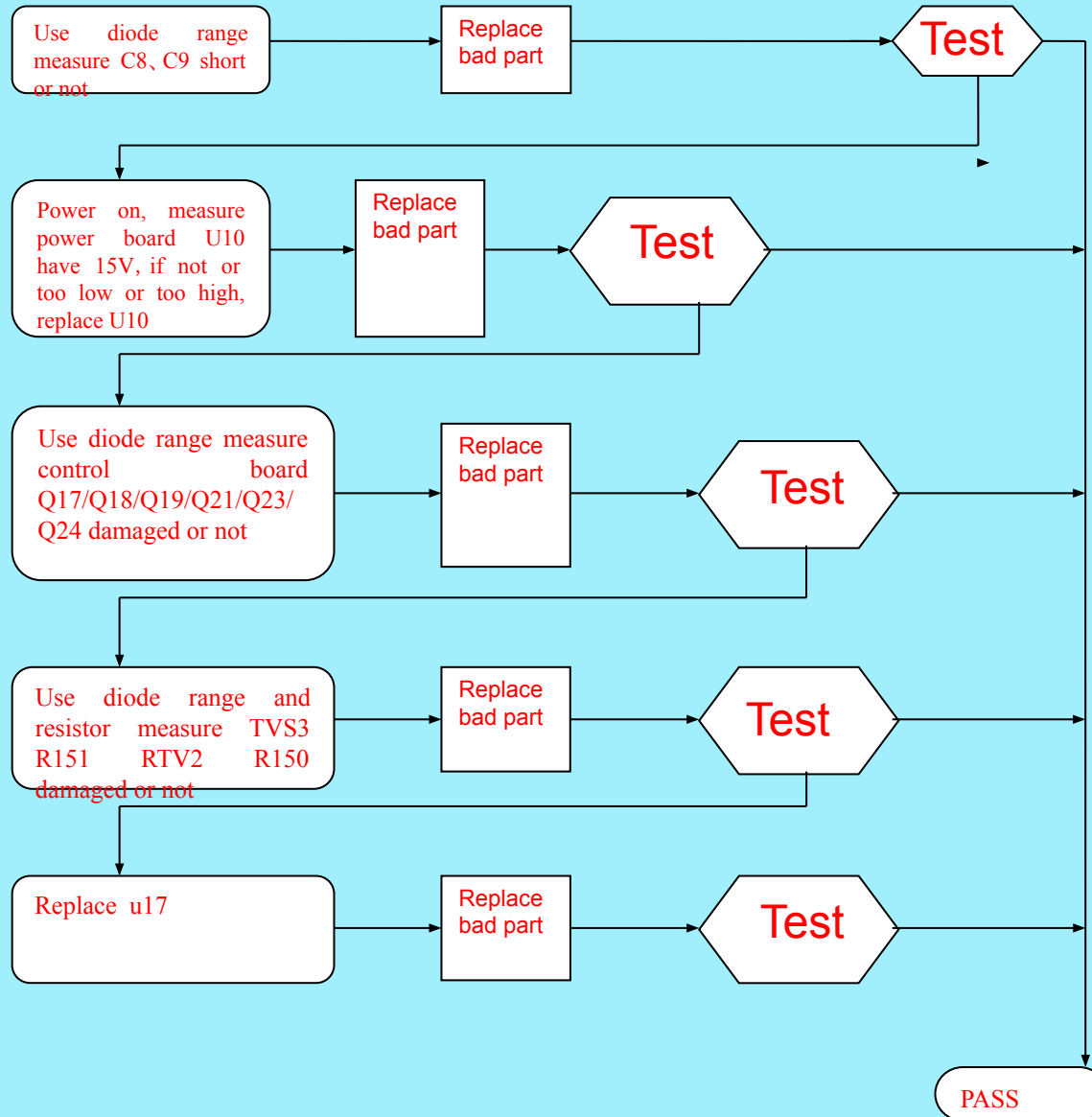

Power board

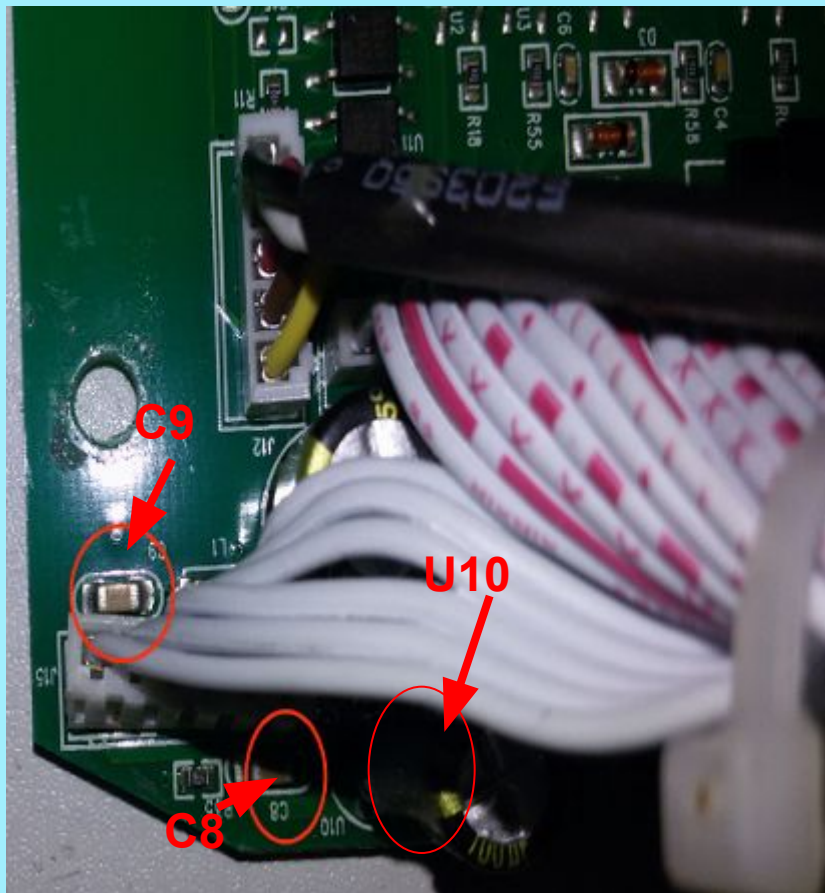

Control board

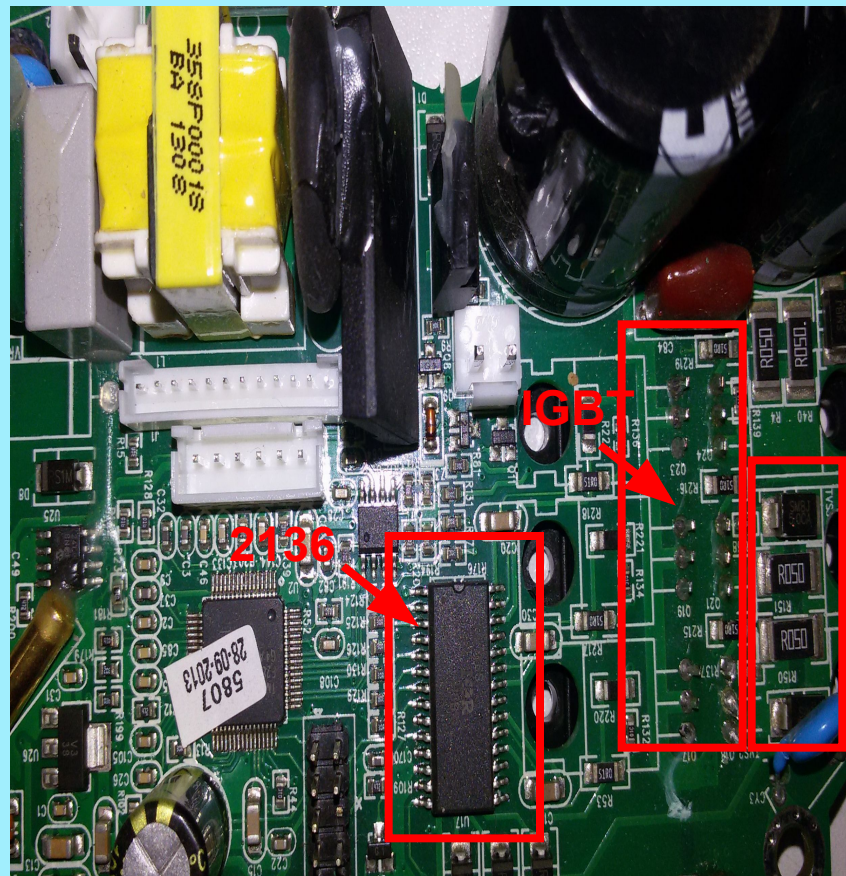

Control board

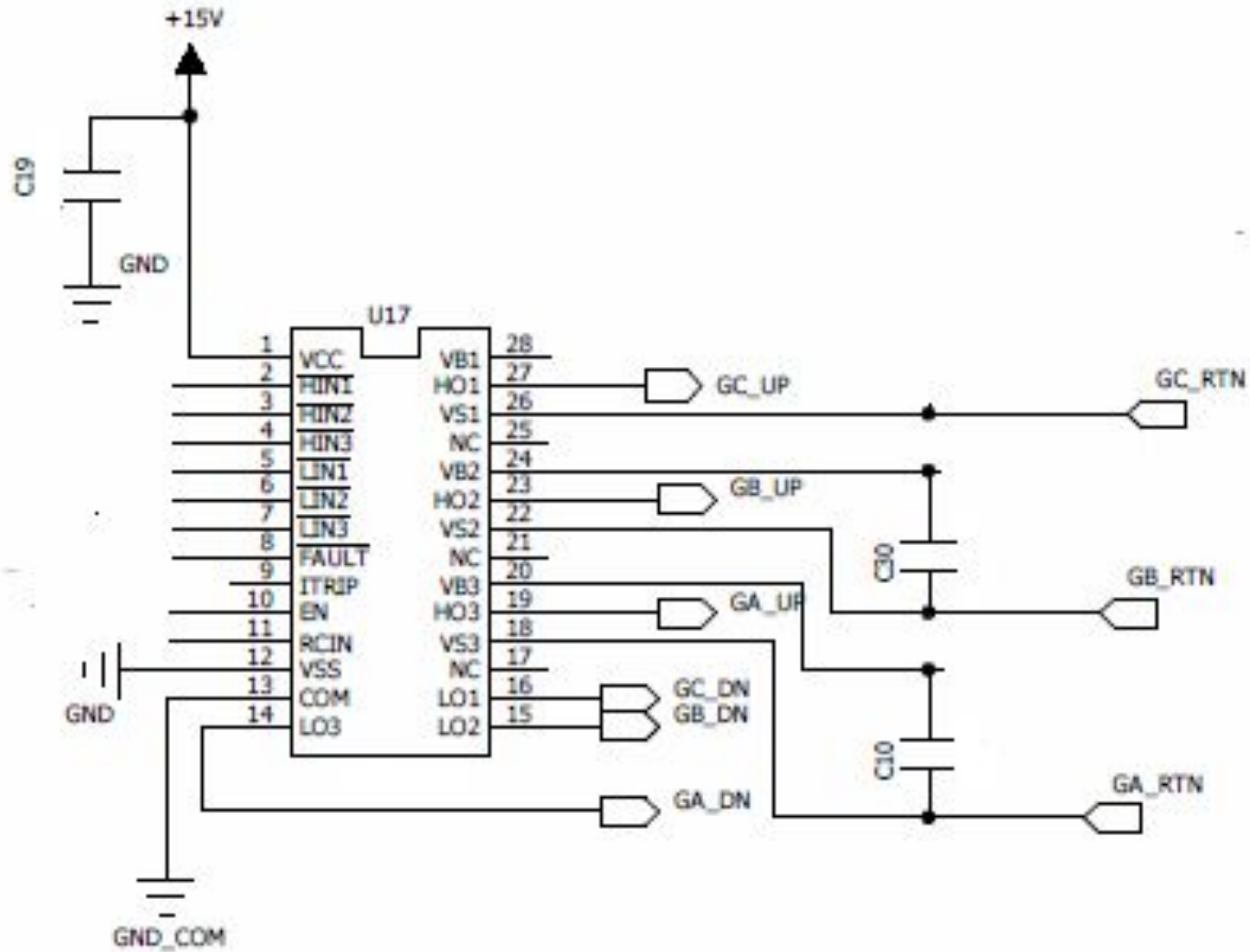

Control board

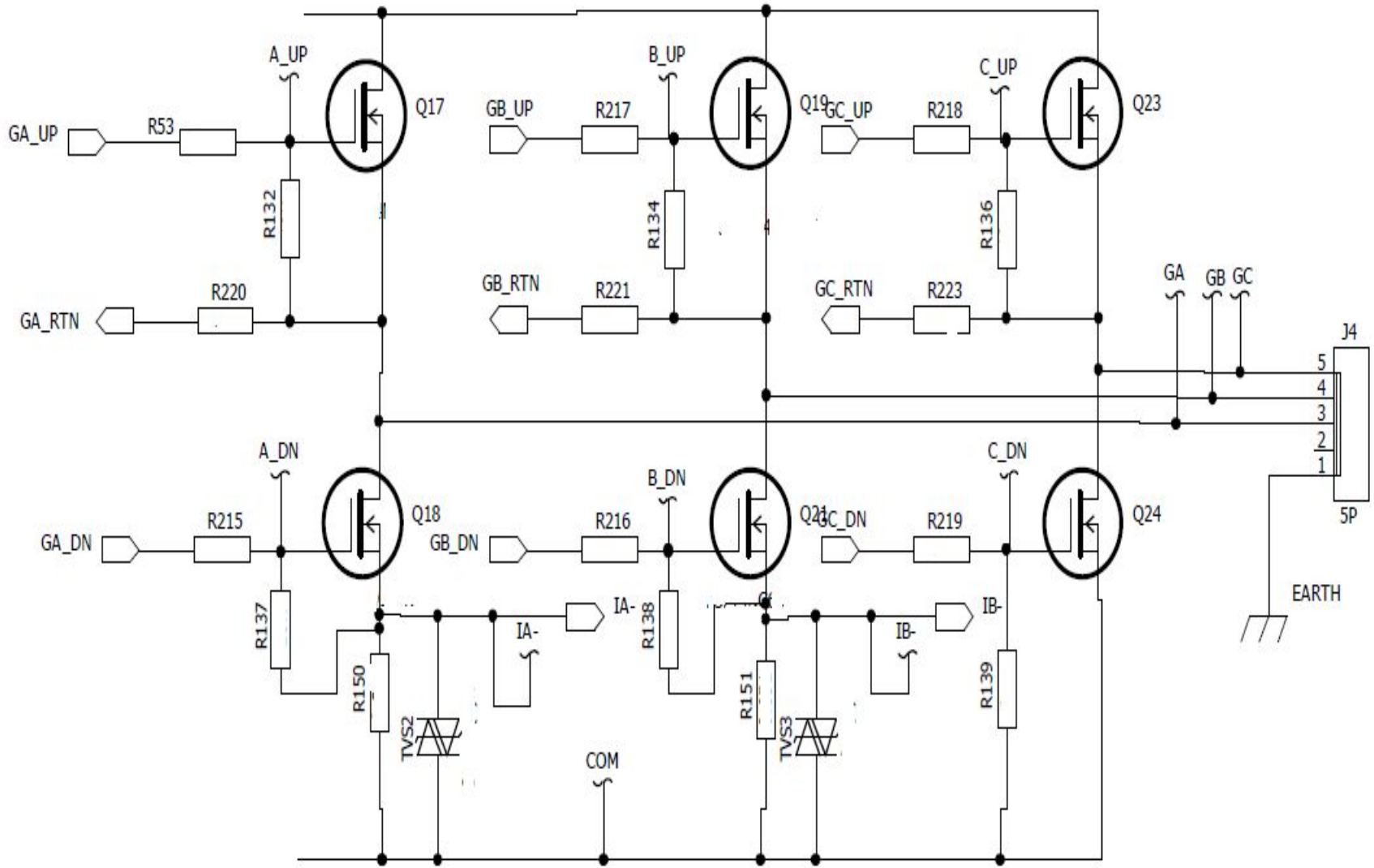

Err-07

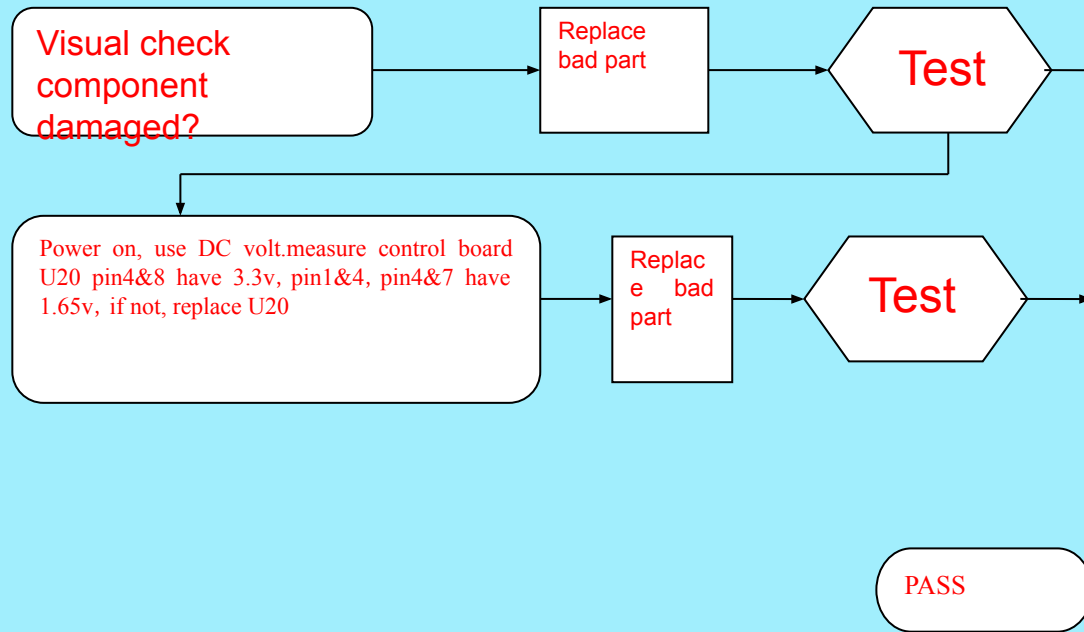

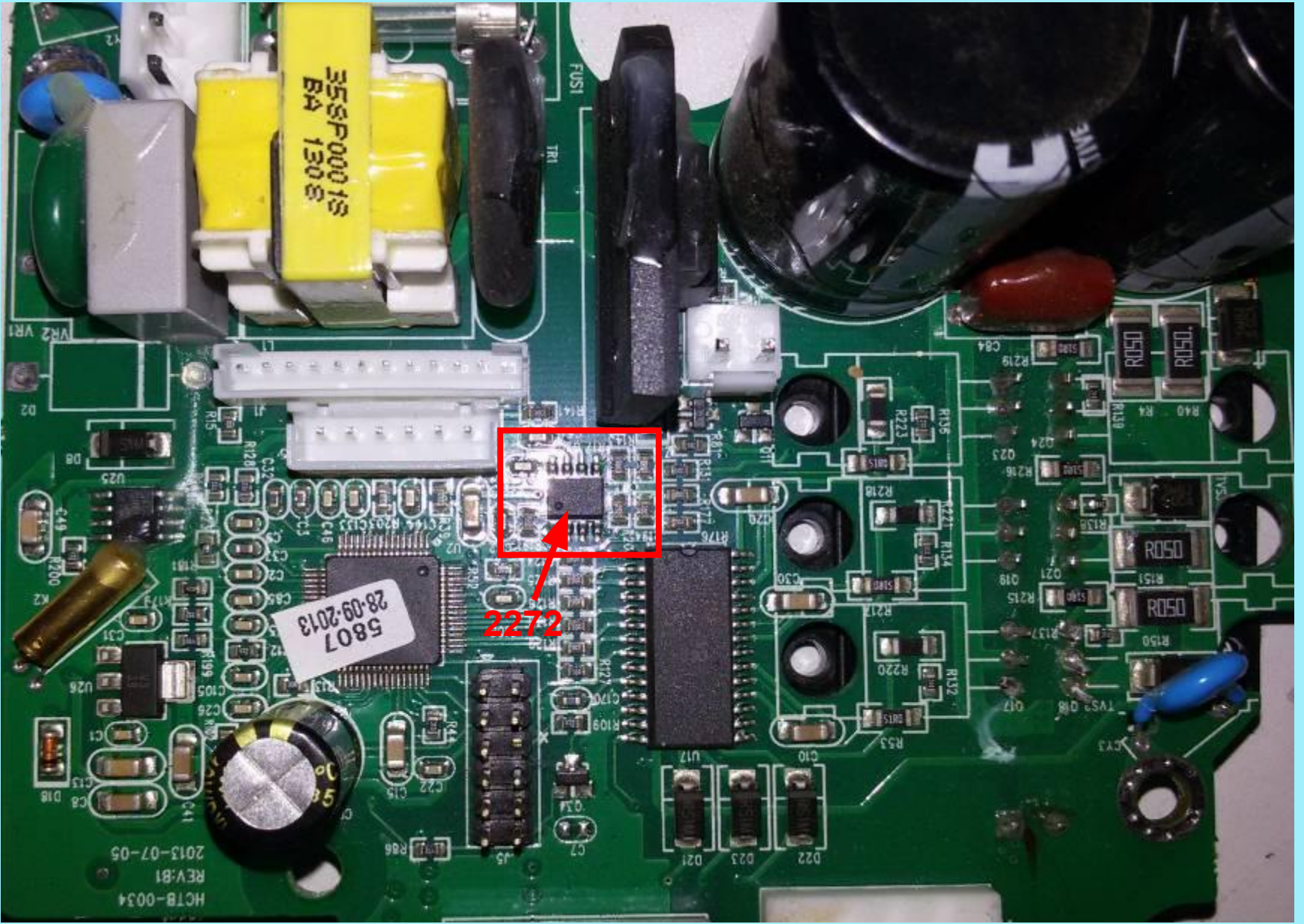

Control board

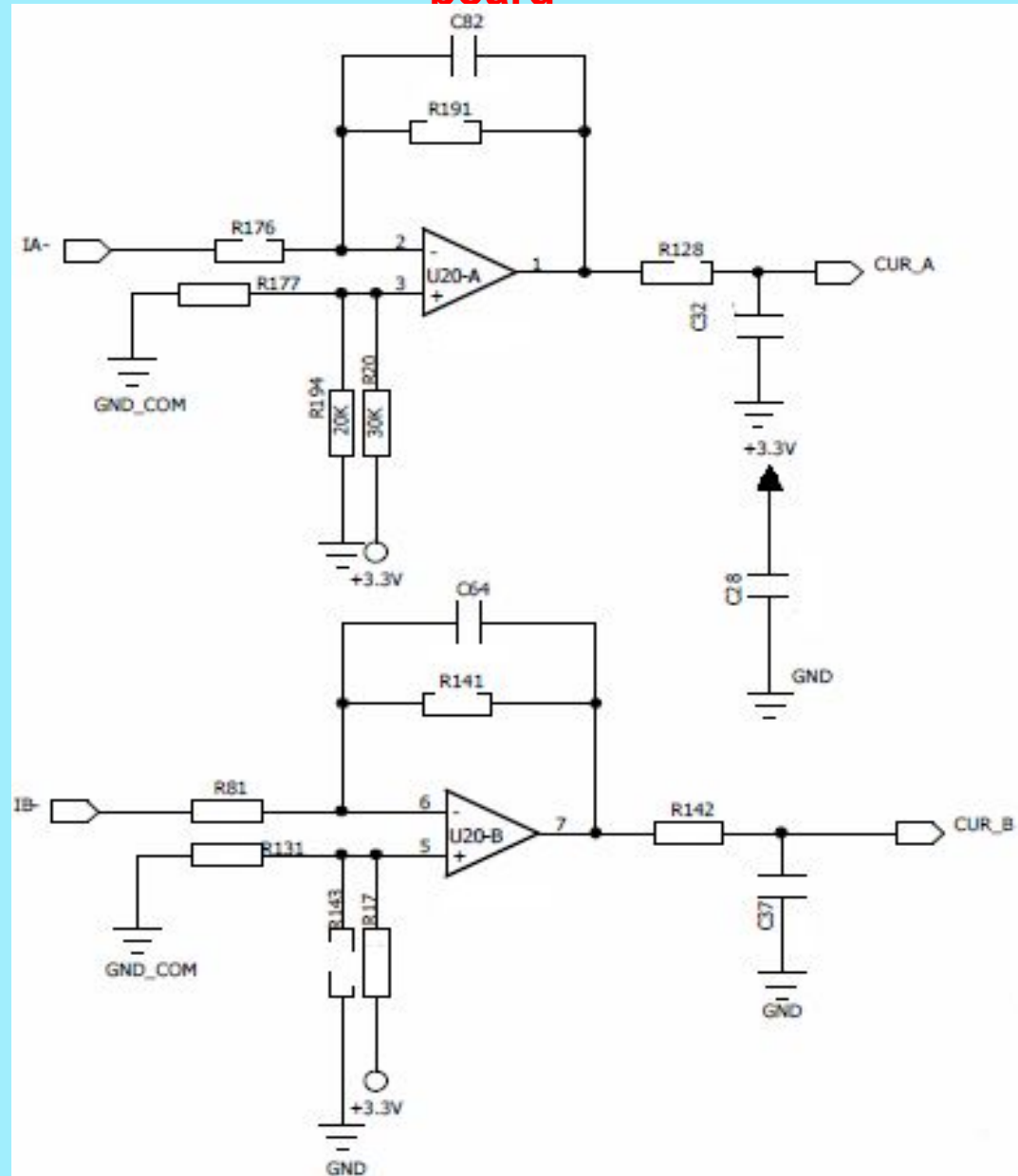

Err-08

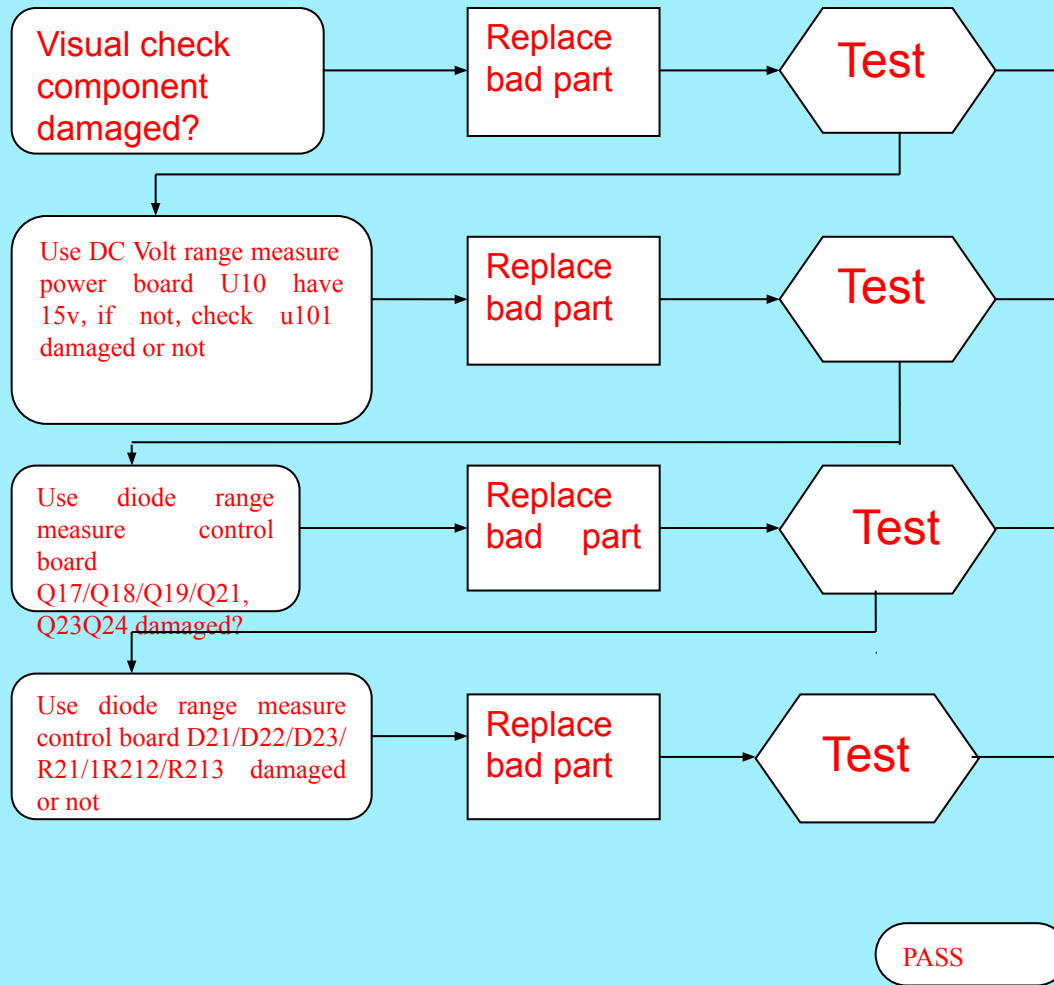

Power board

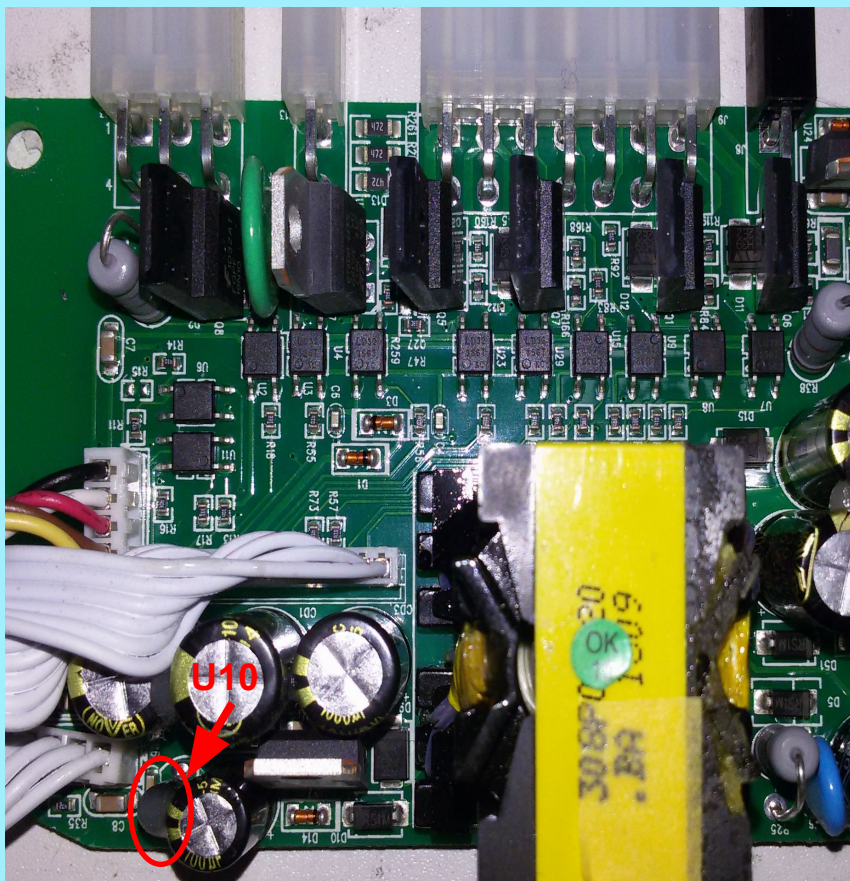

Control board

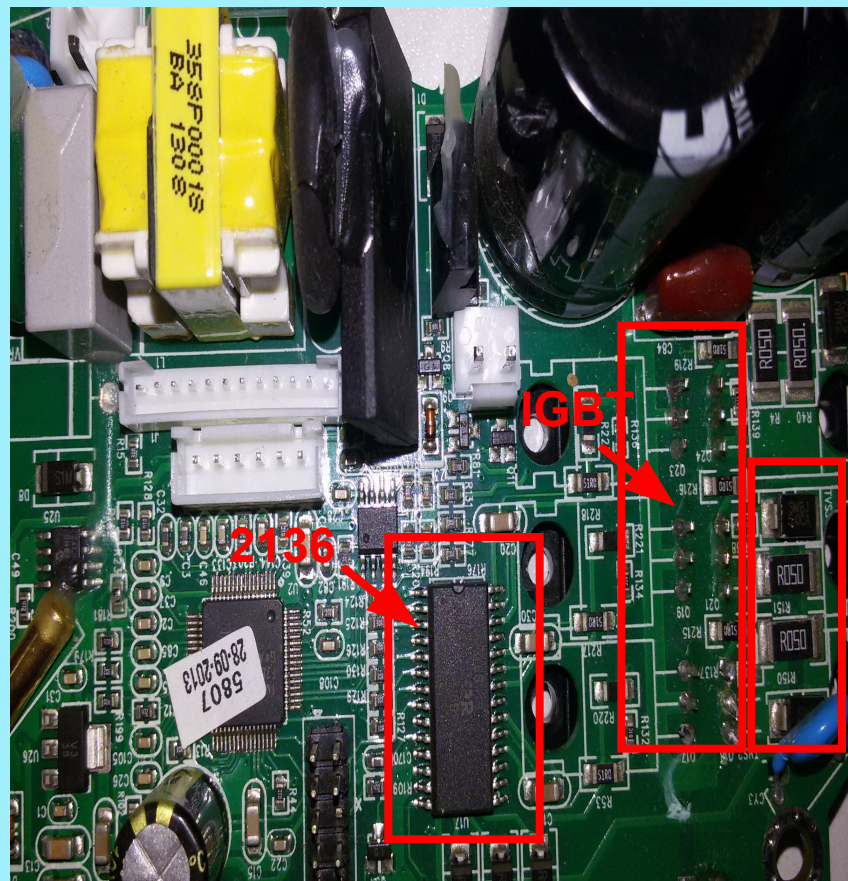

Control board

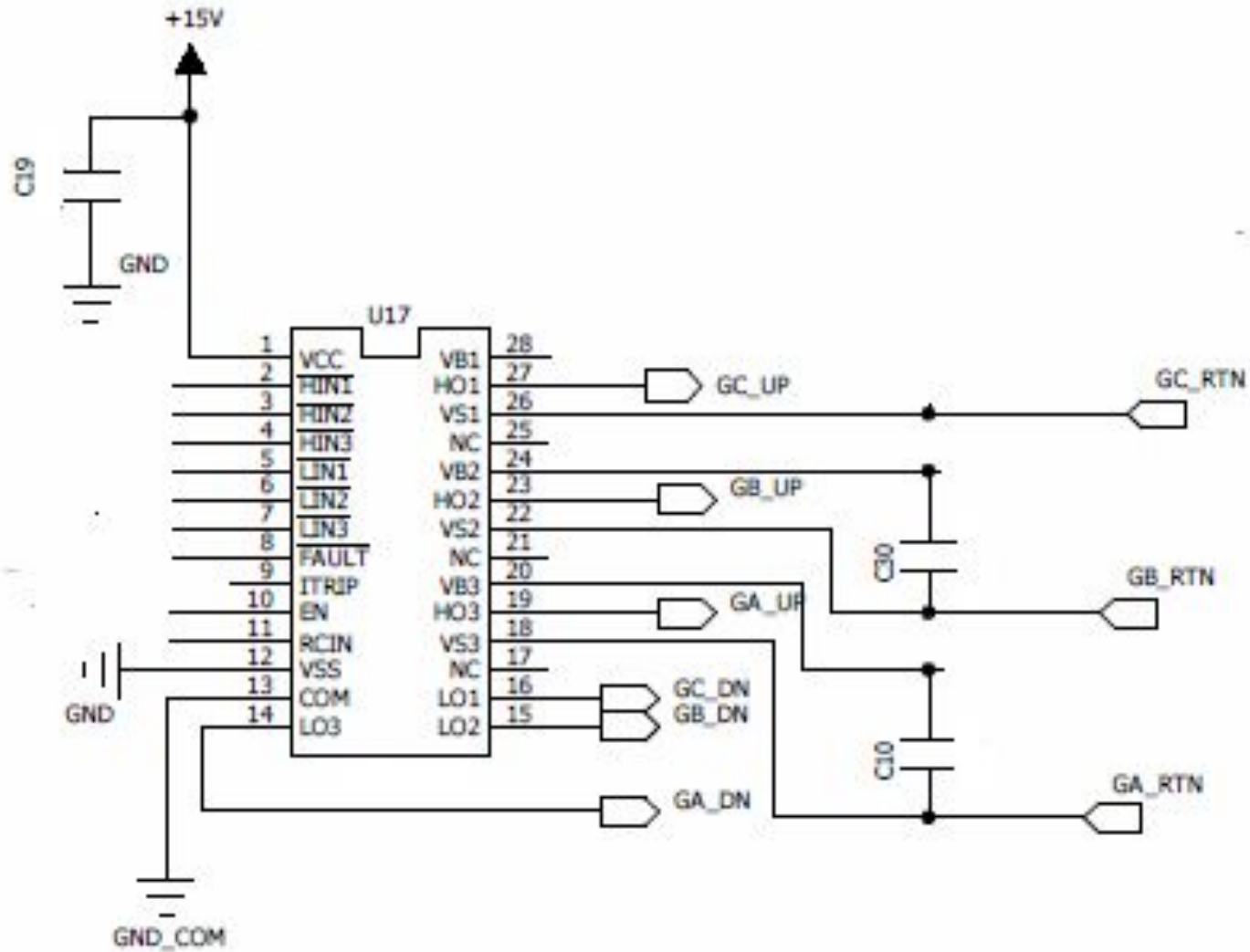

Control board

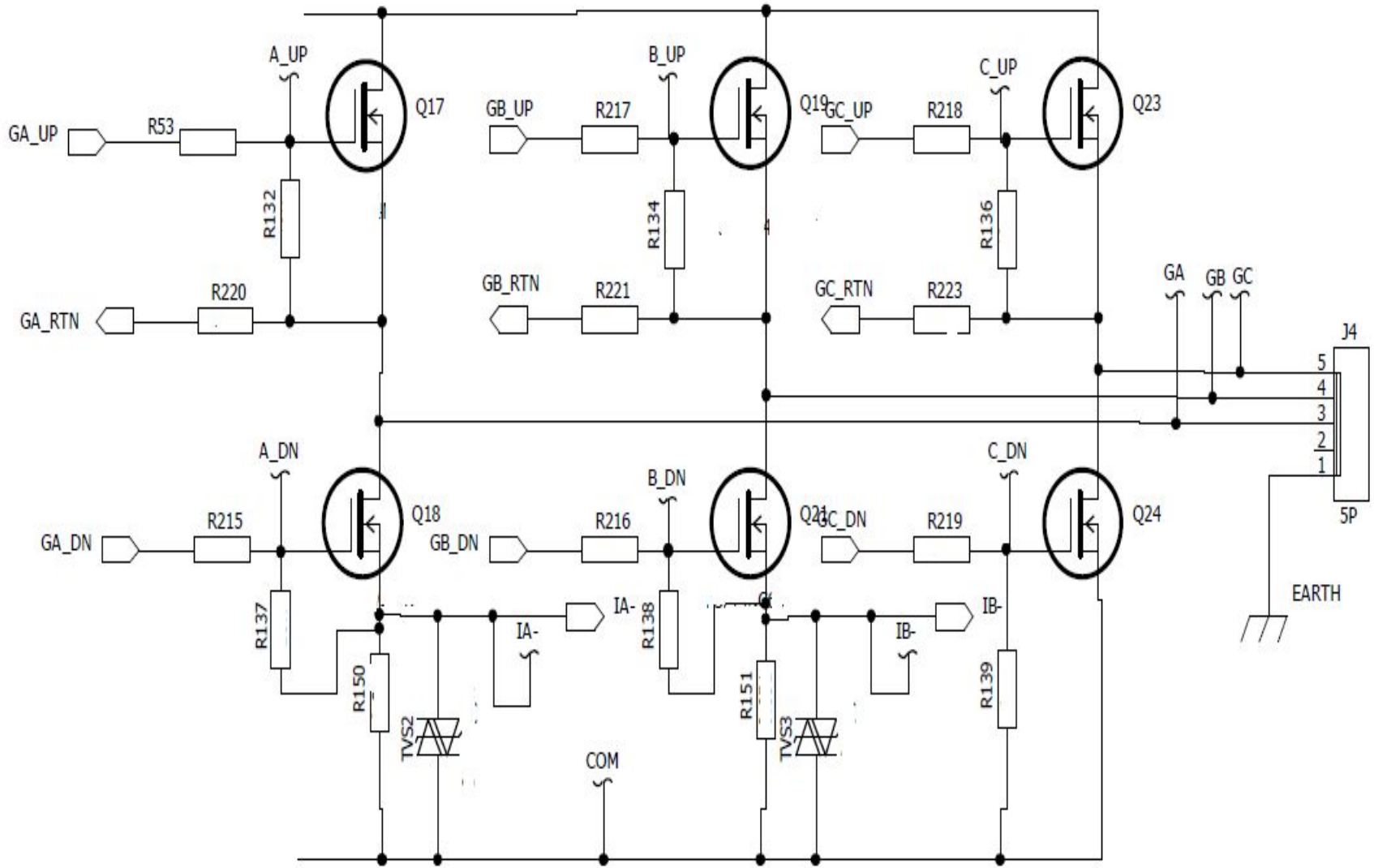

Err-09

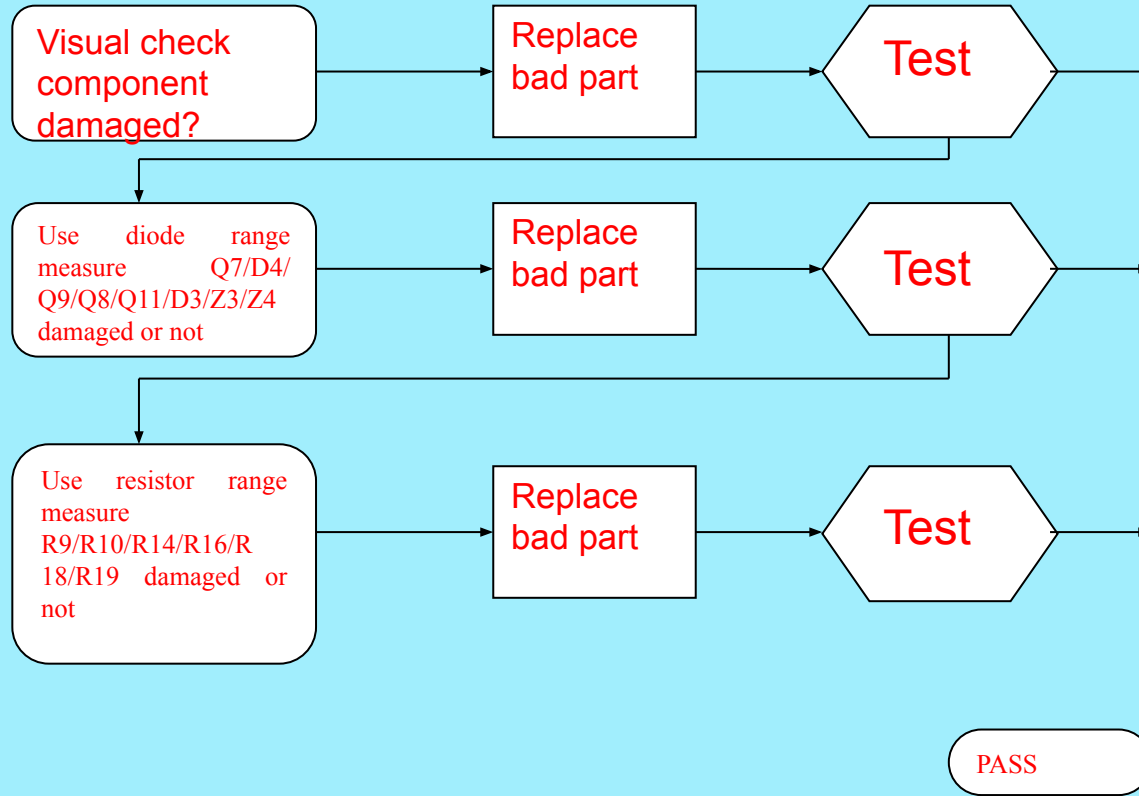

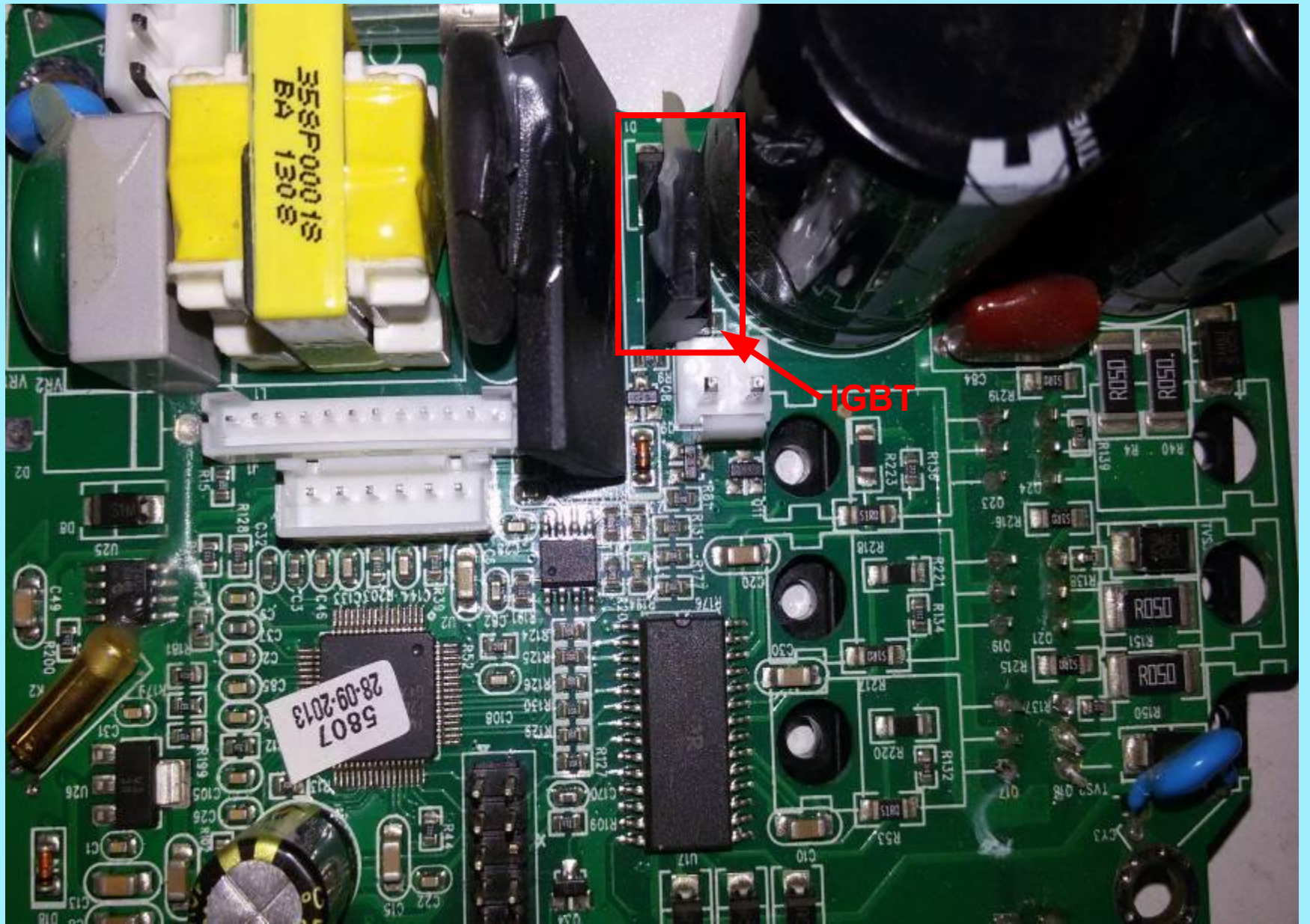

Power Supply

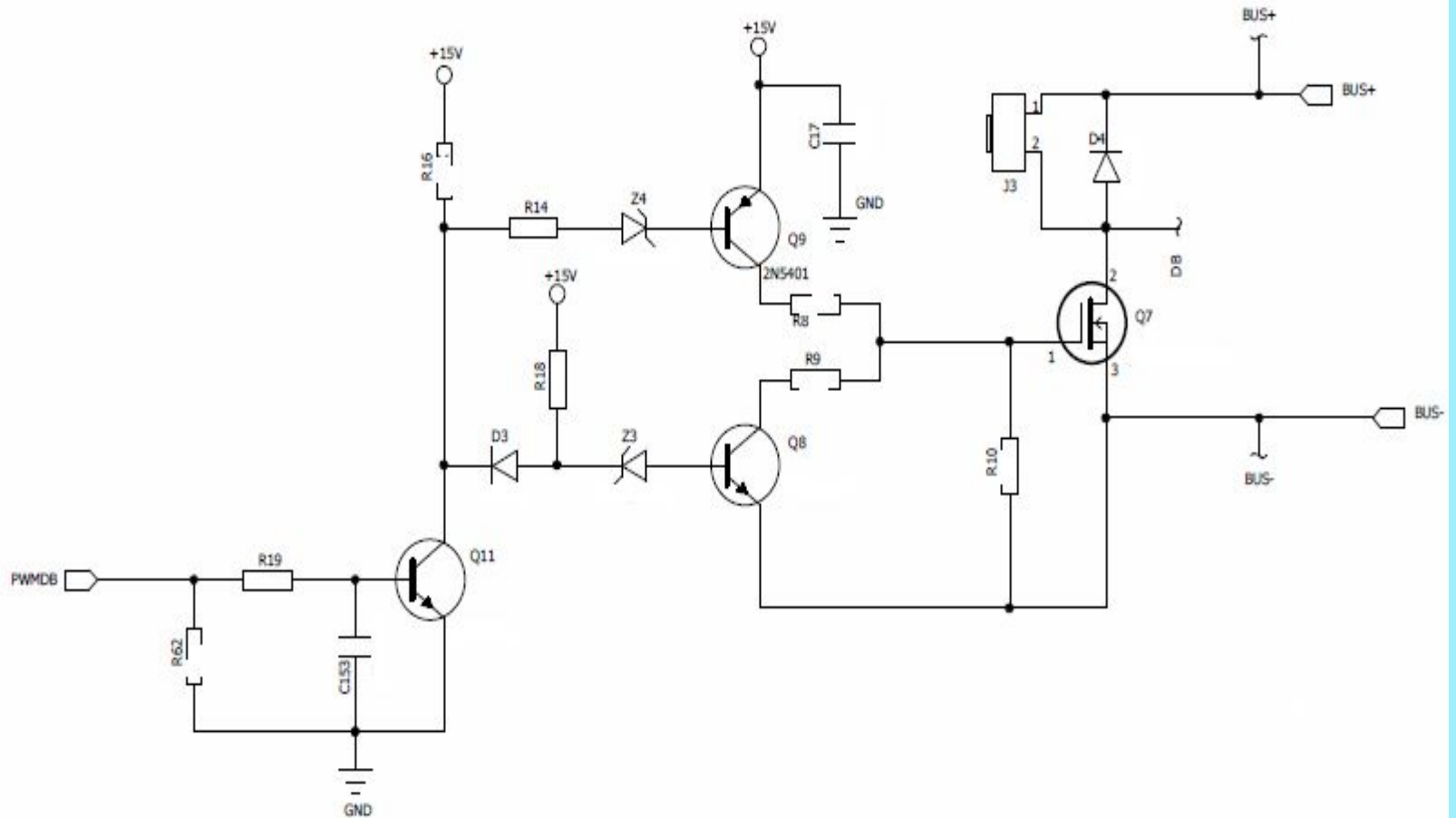

Err-10

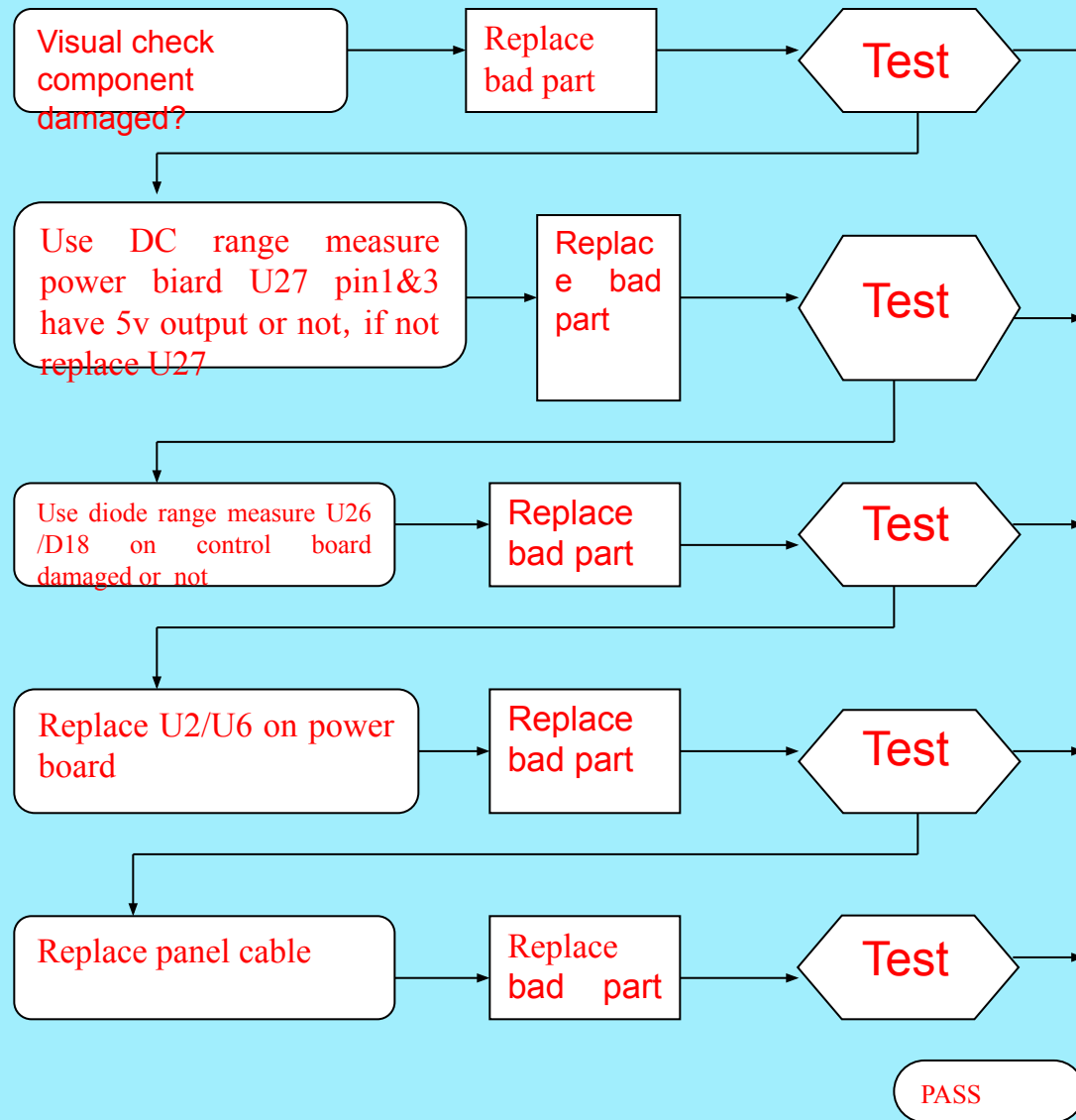

POWER BOARD

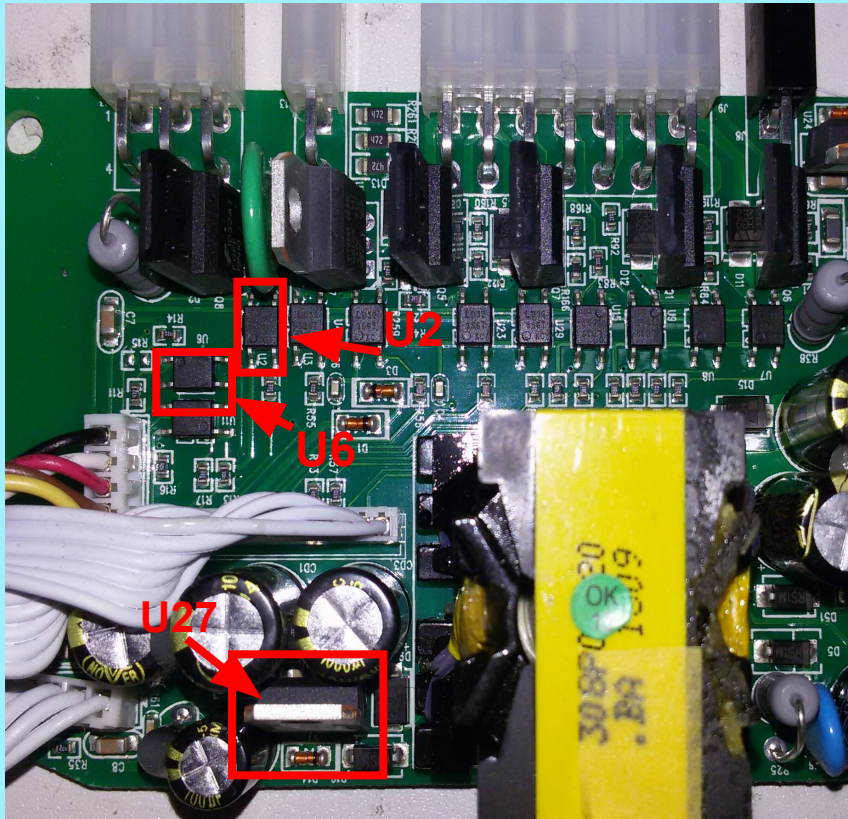

CONTROL BOARD

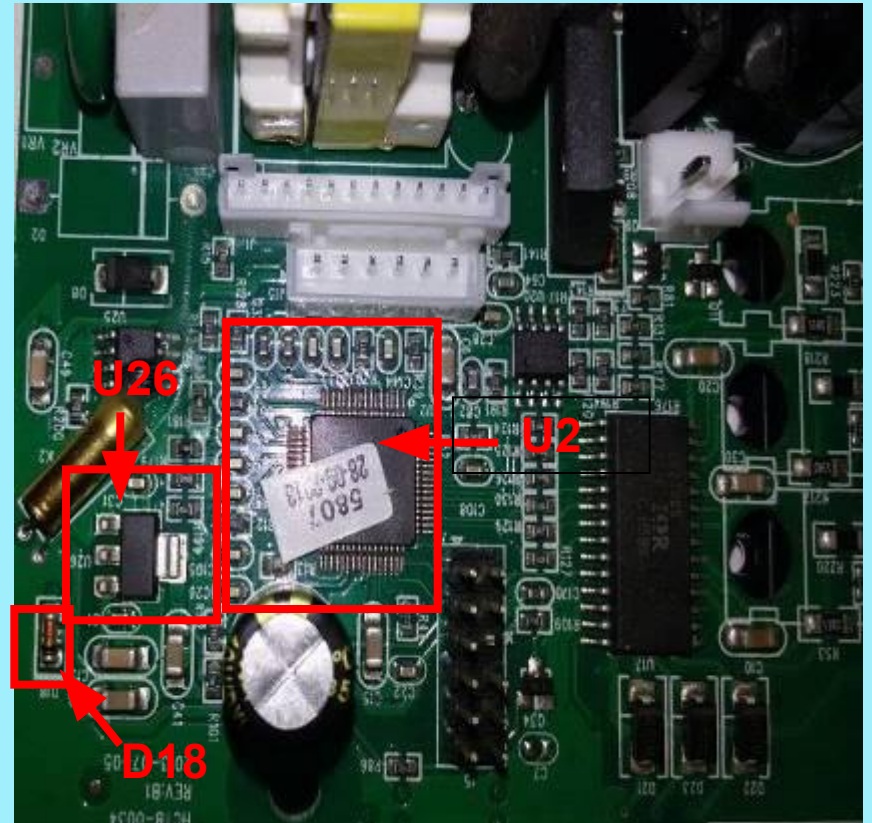

POWER BOARD

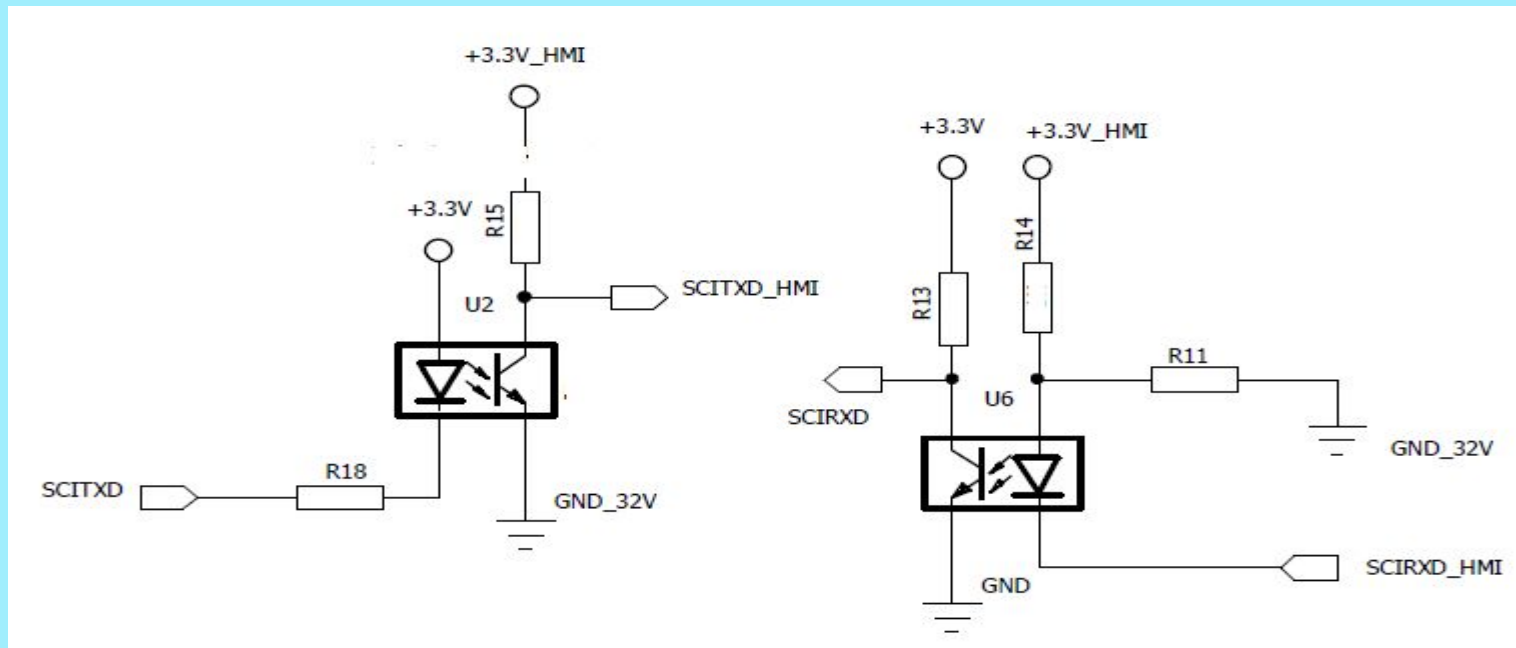
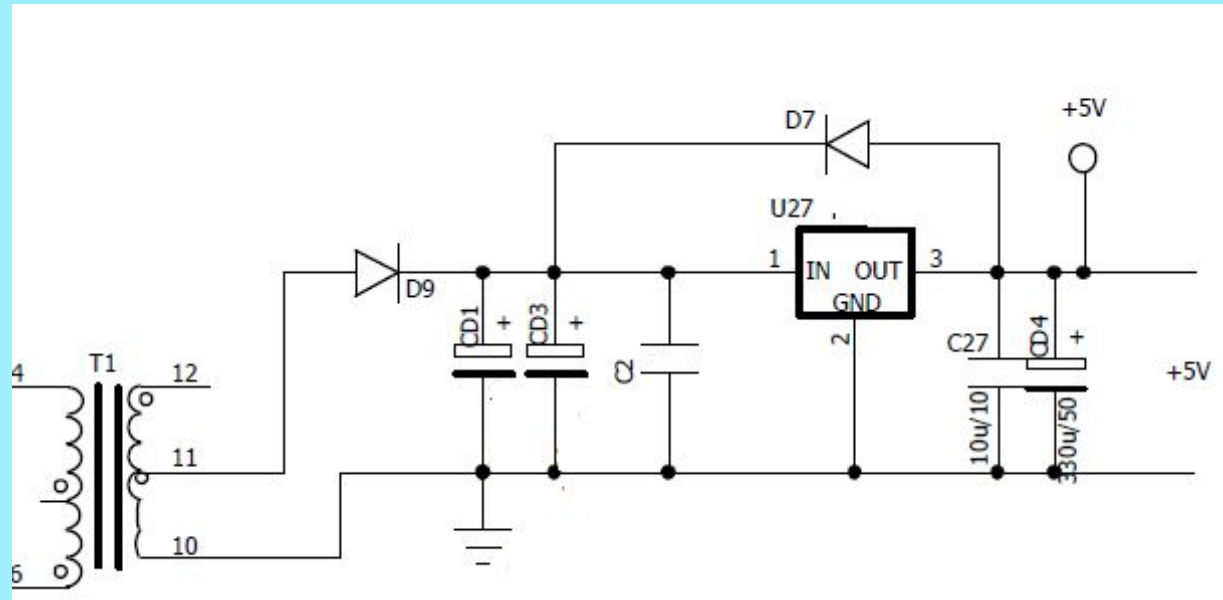

CONTROL BOARD

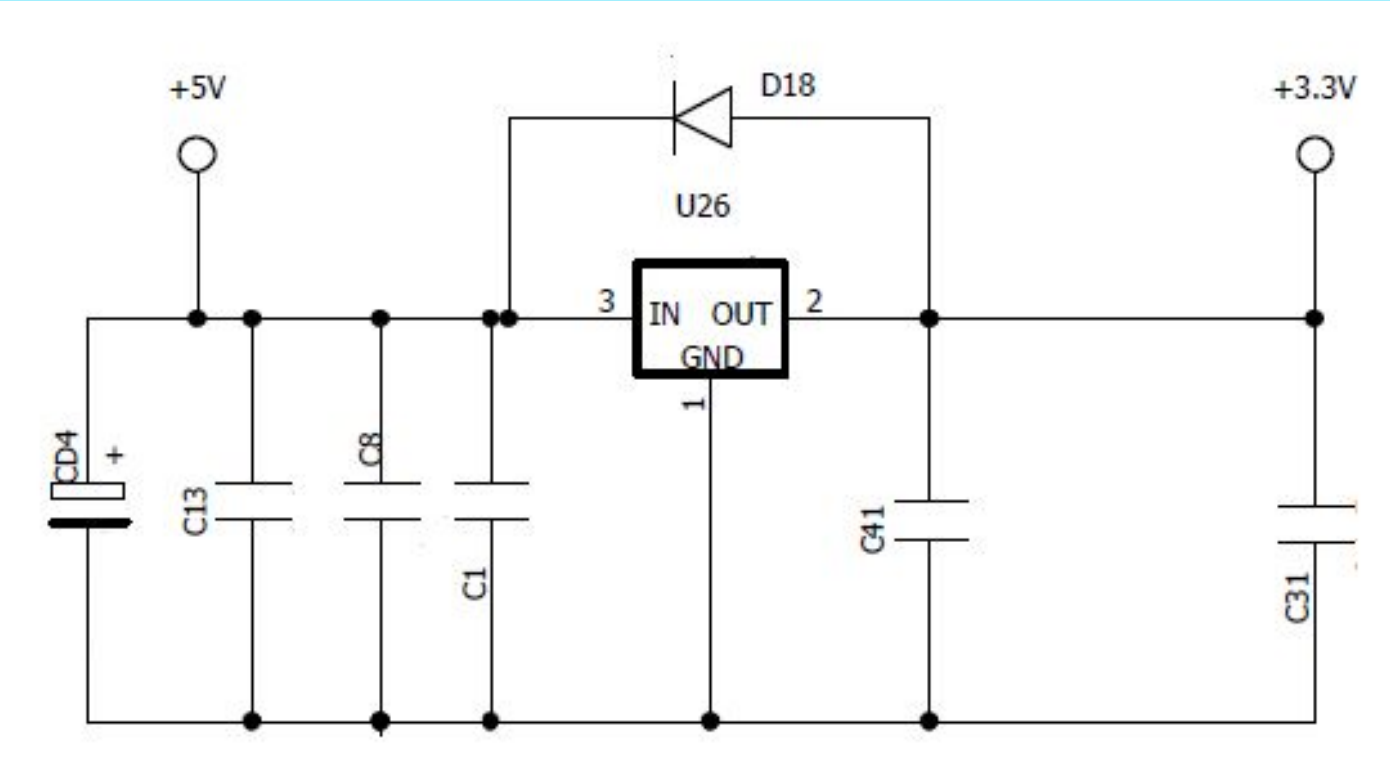

Err-13

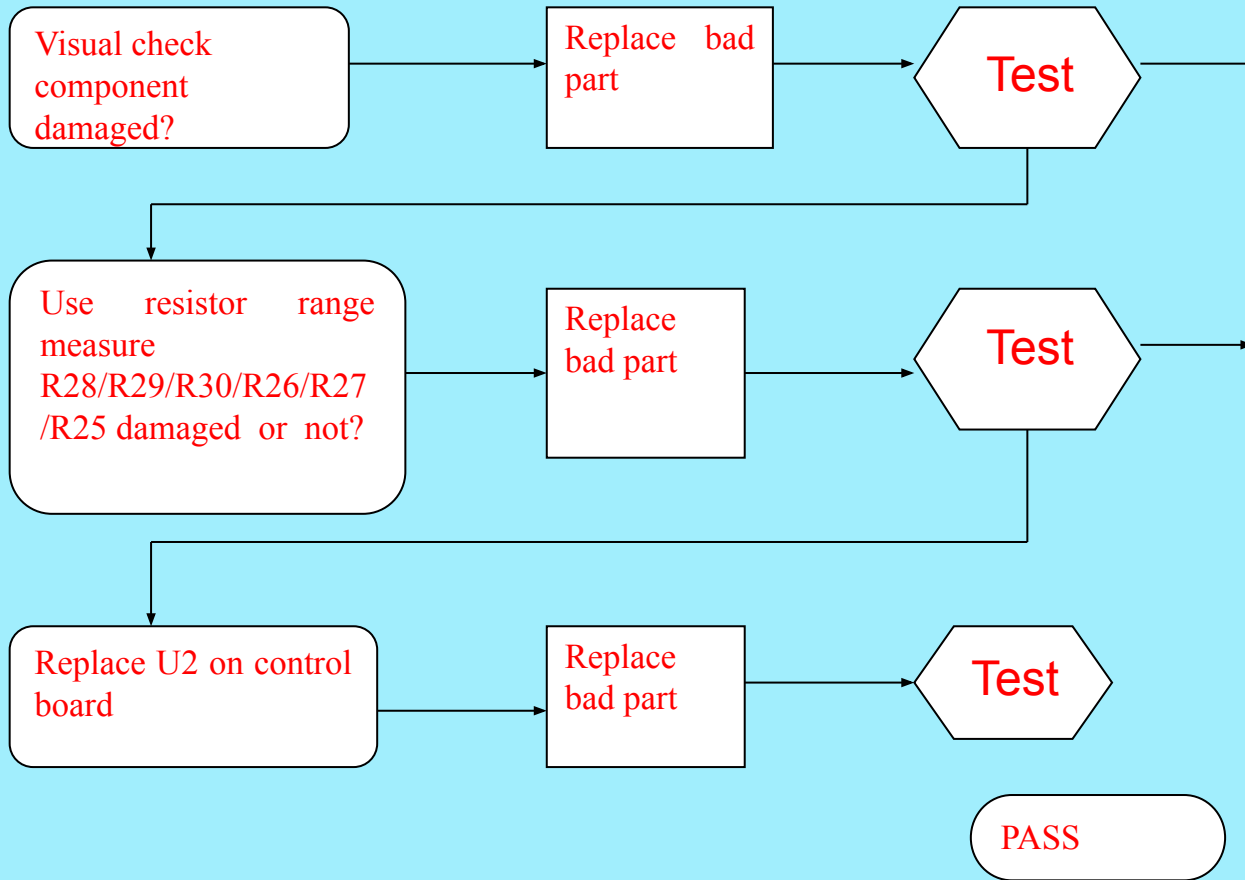

CONTROL BOARD

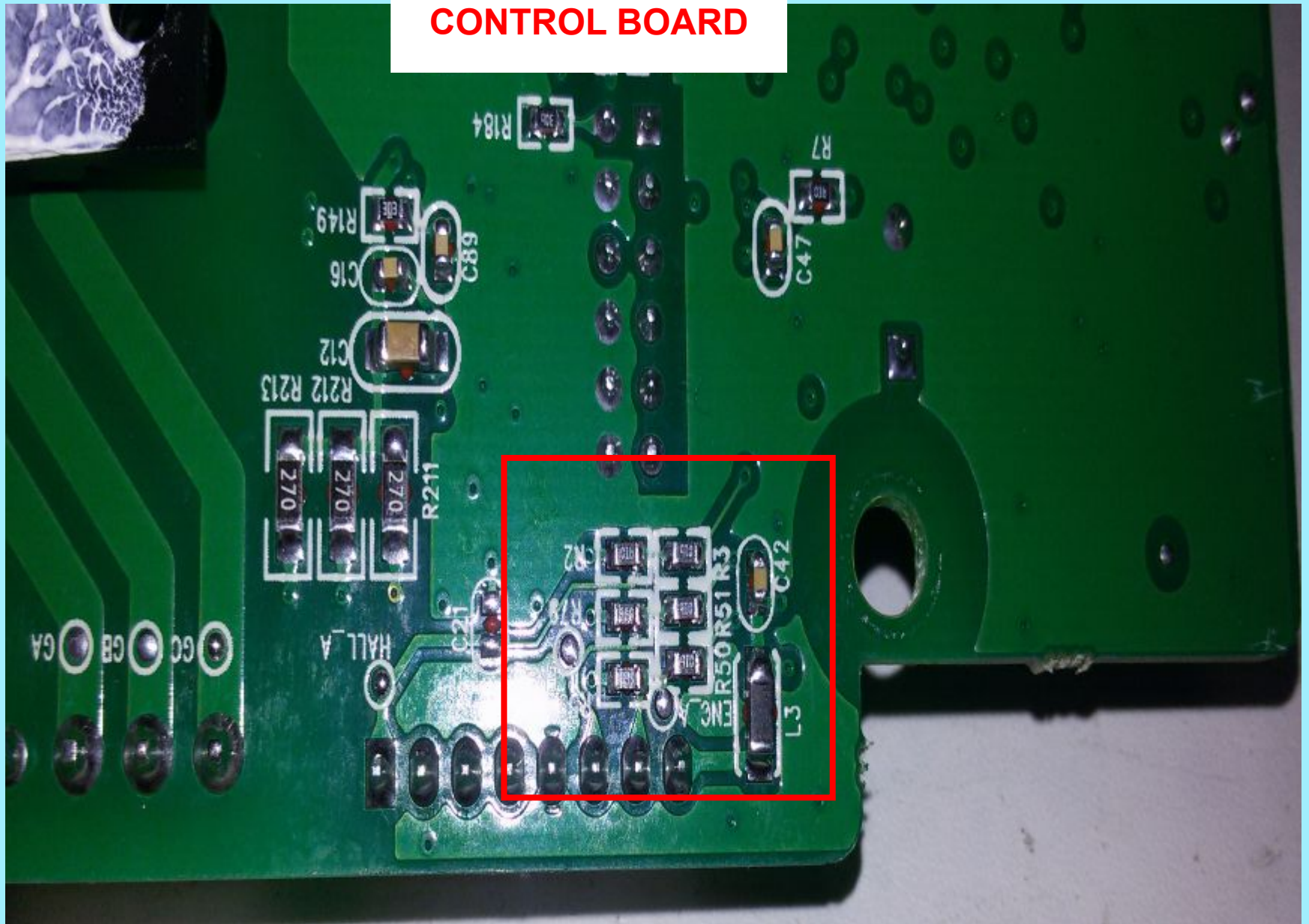

CONTROL BOARD

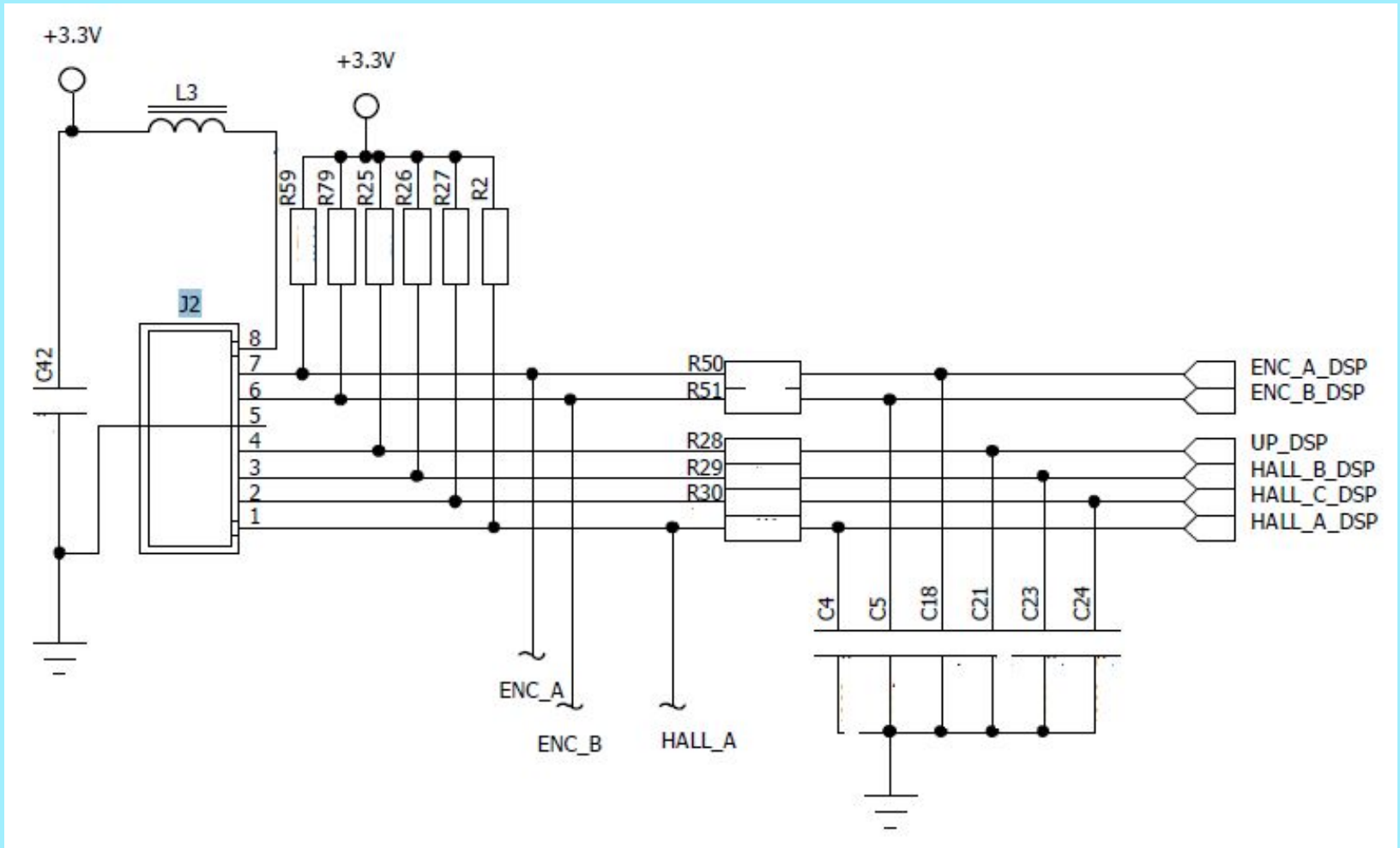

AHE59

Err-01

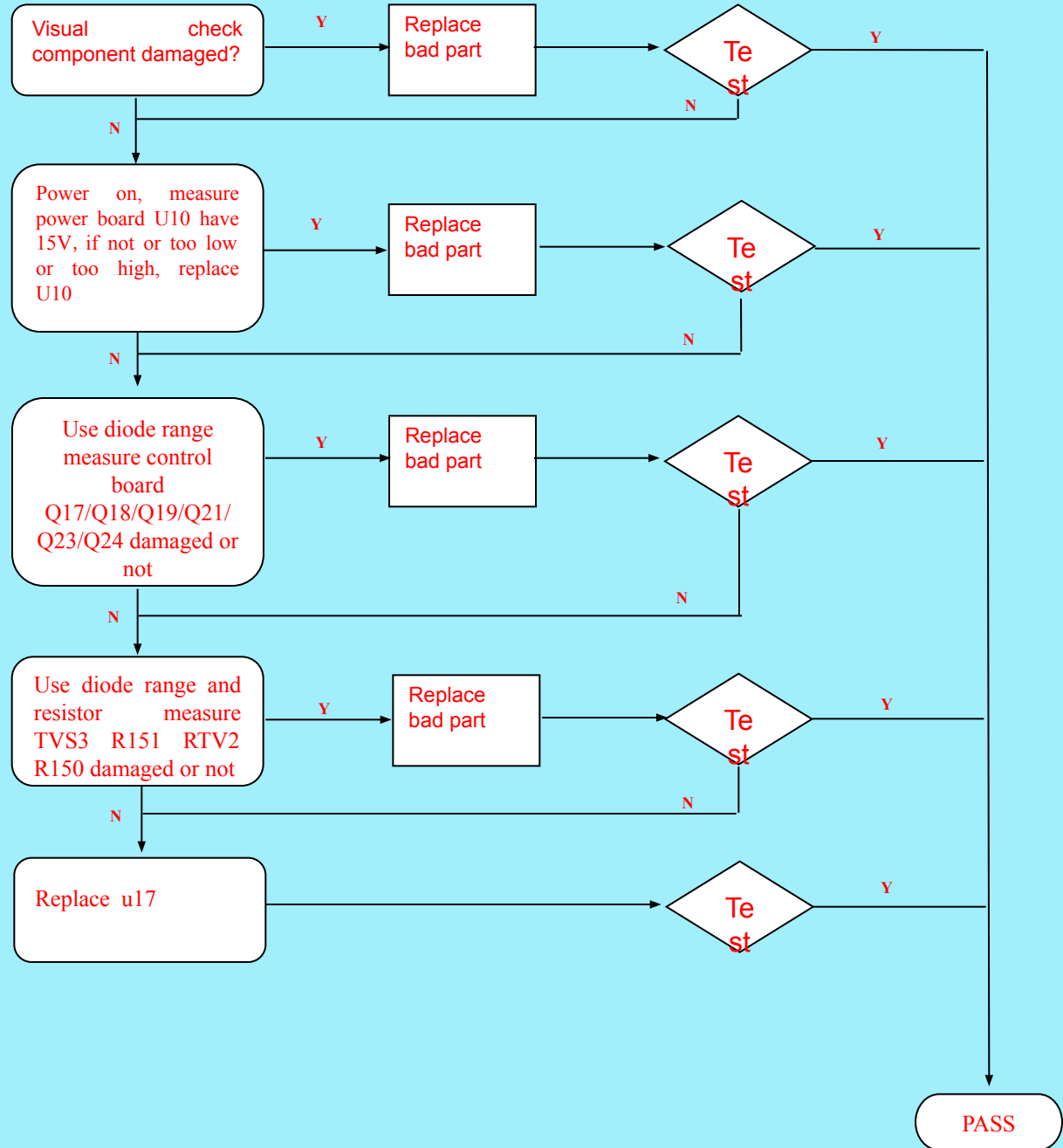

Positive

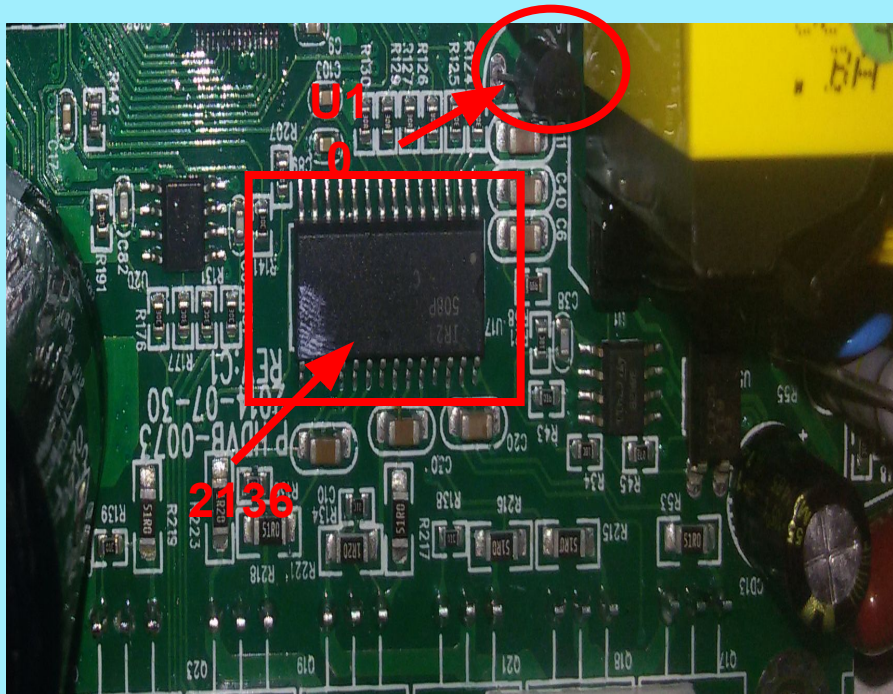

Reverse side

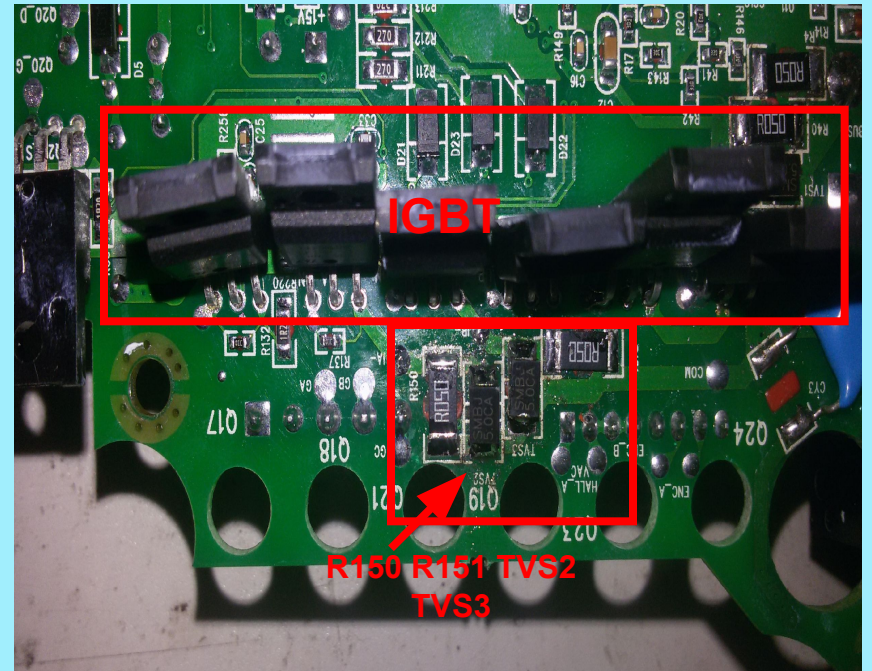

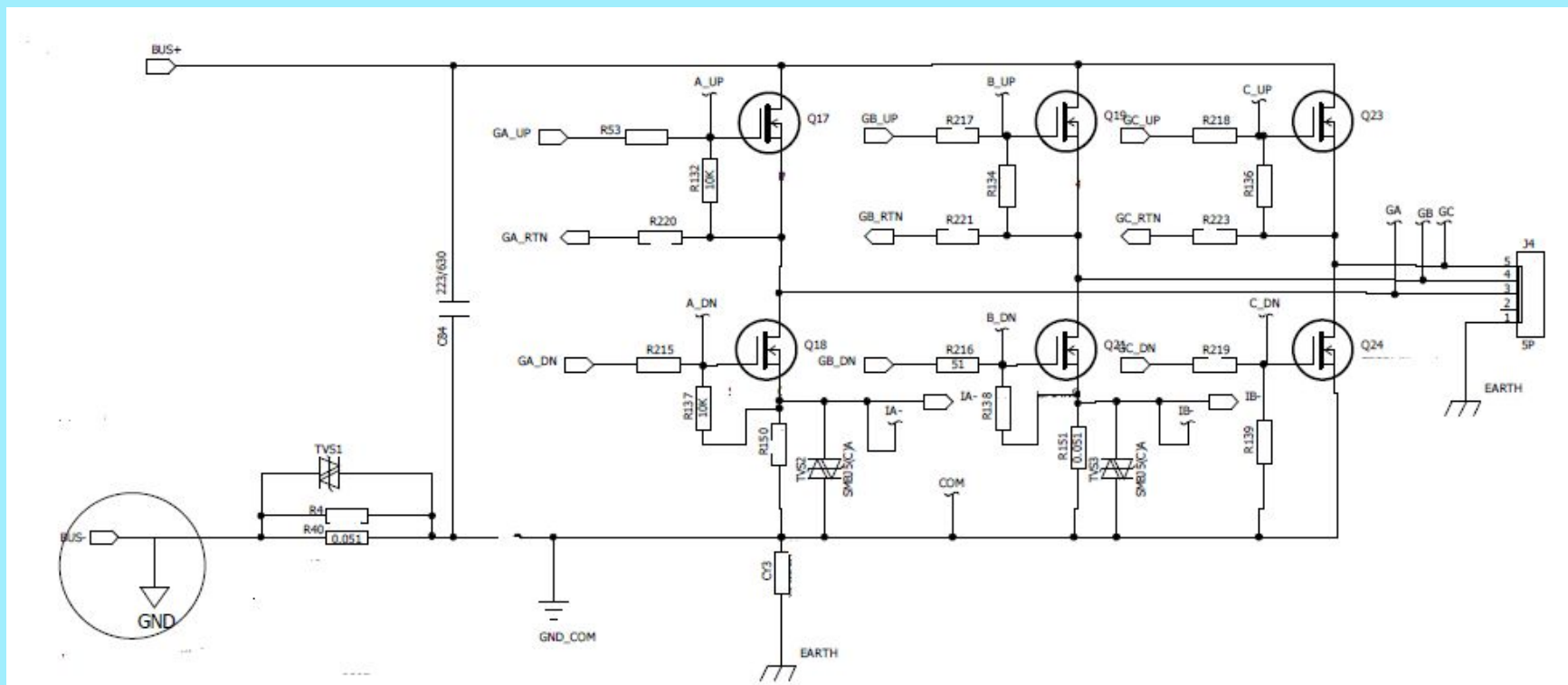

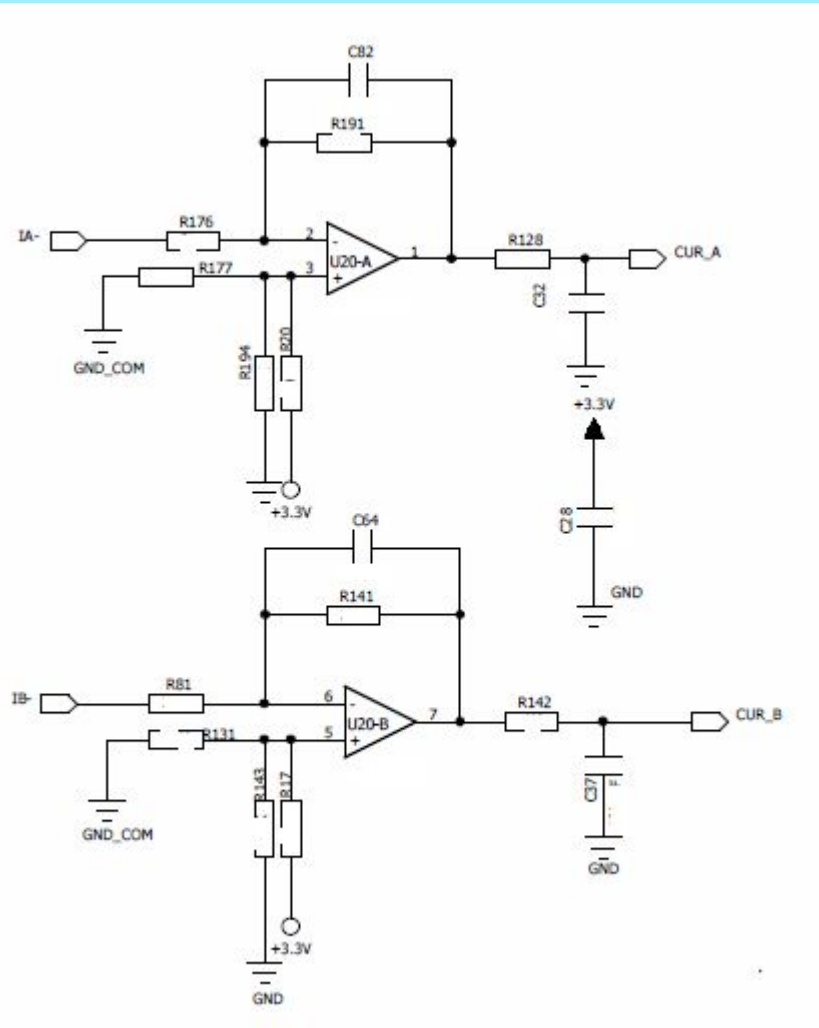

Err-08

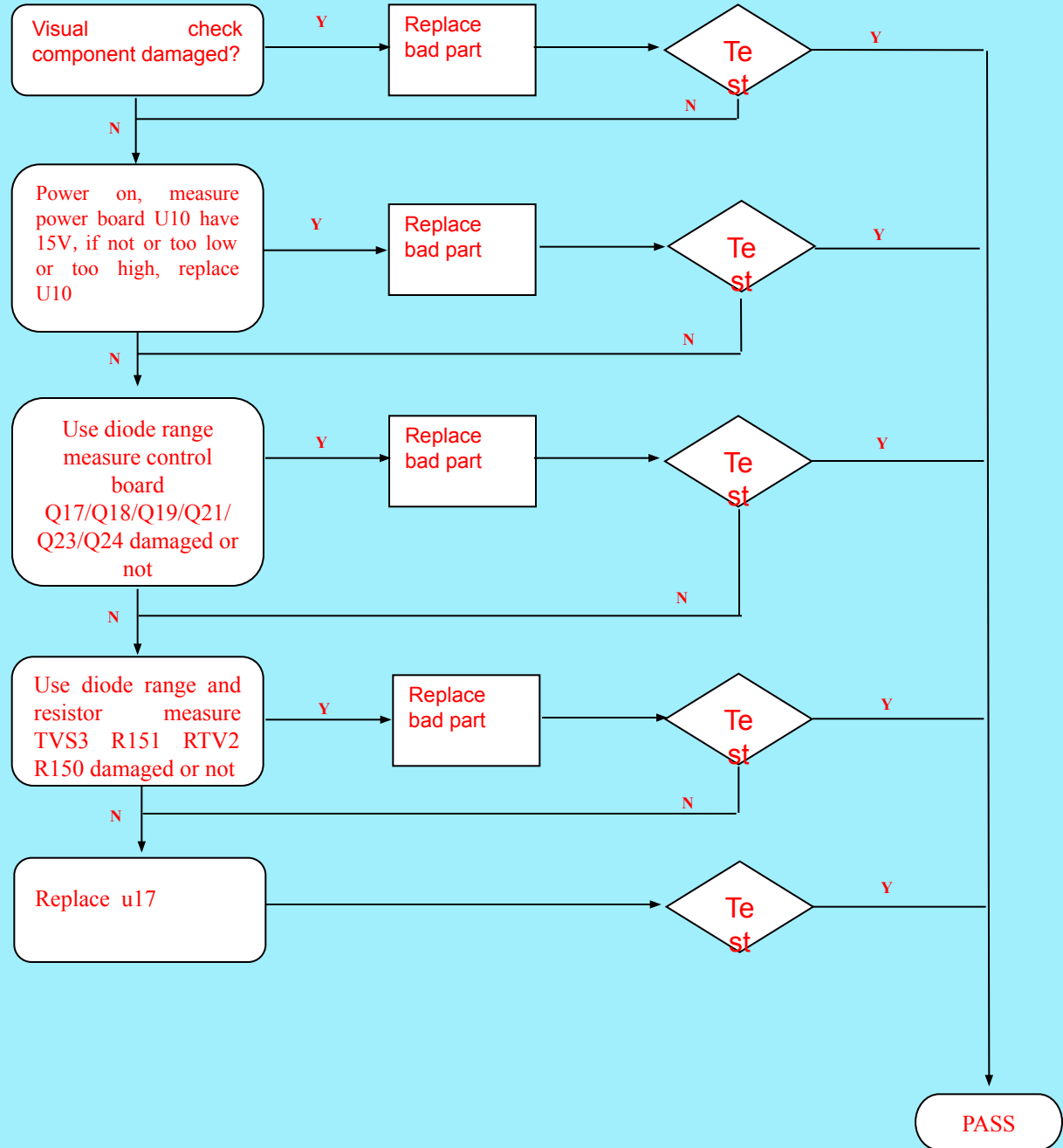

Positive

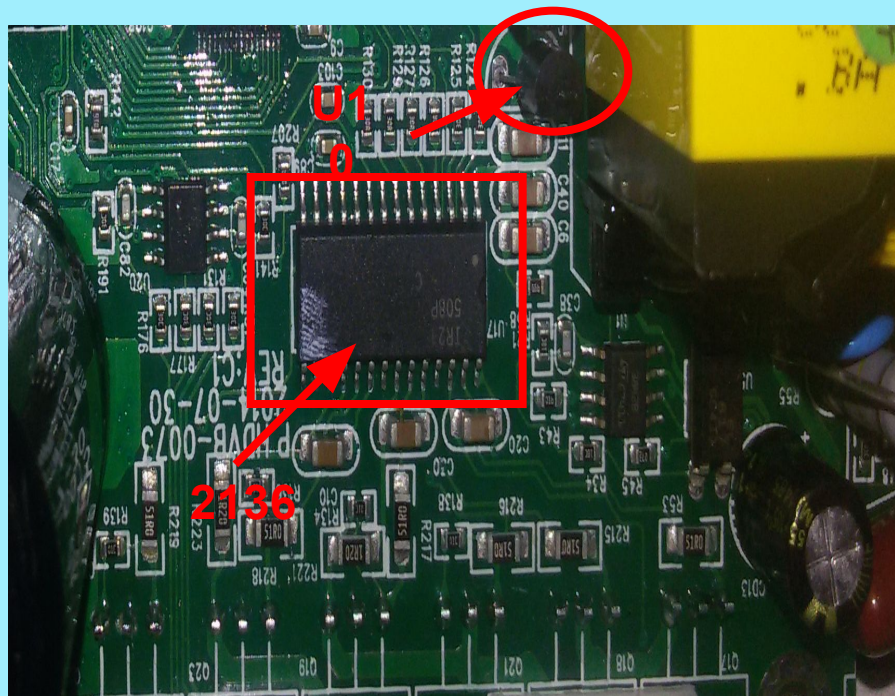

Reverse side

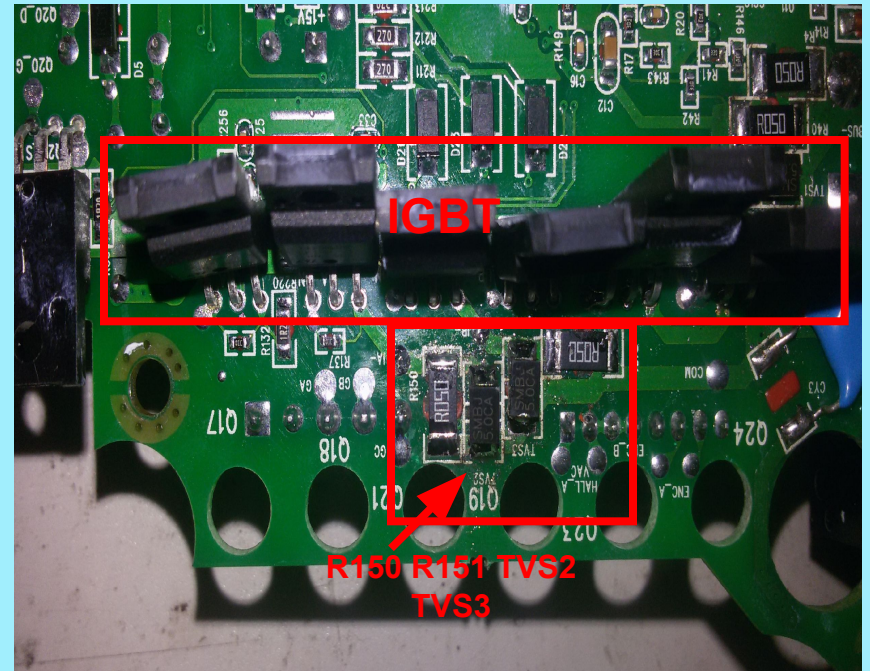

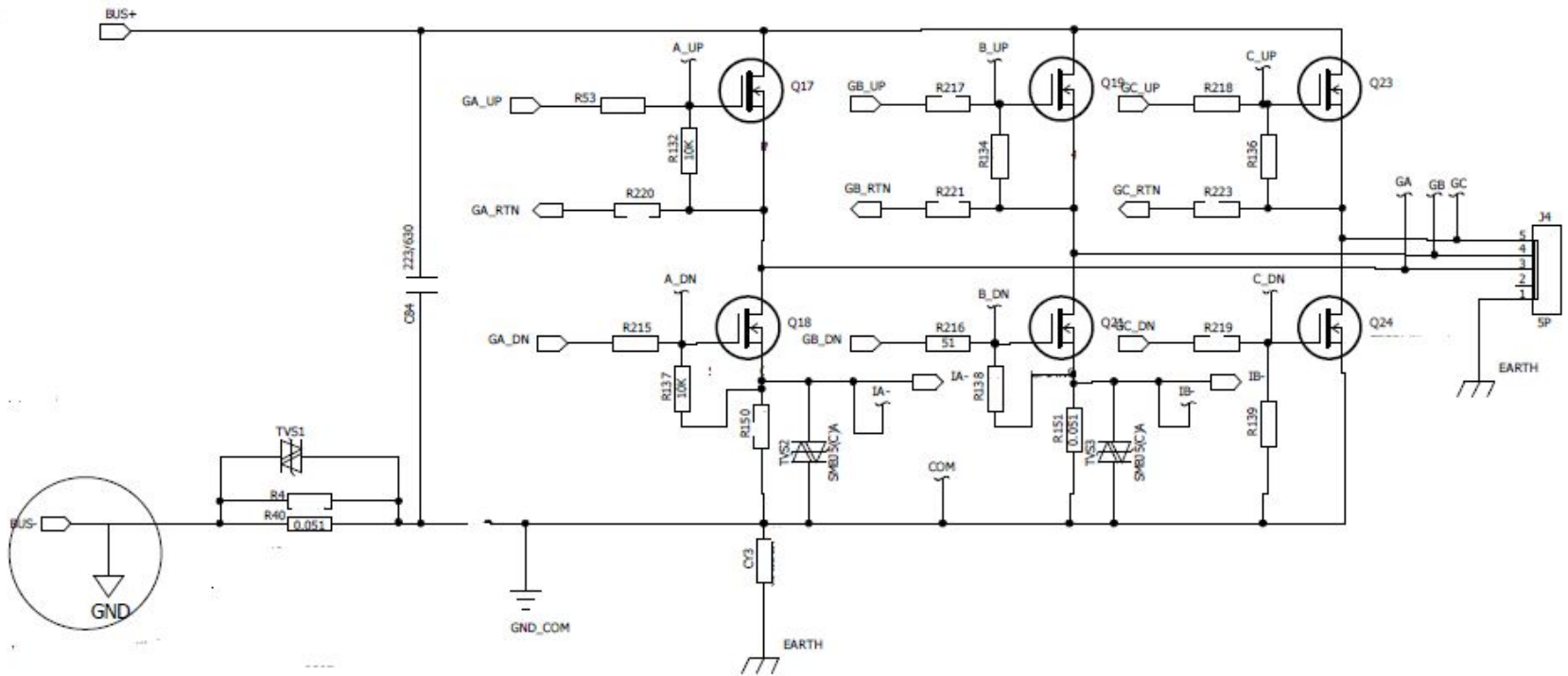

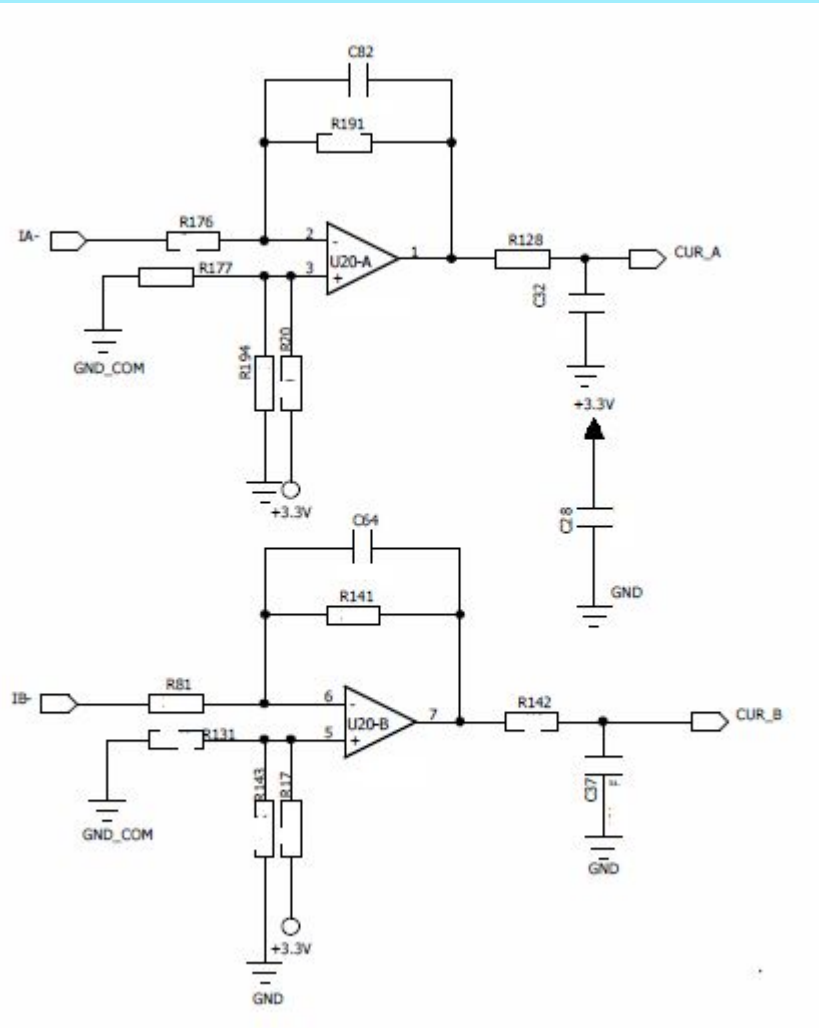

Err-10

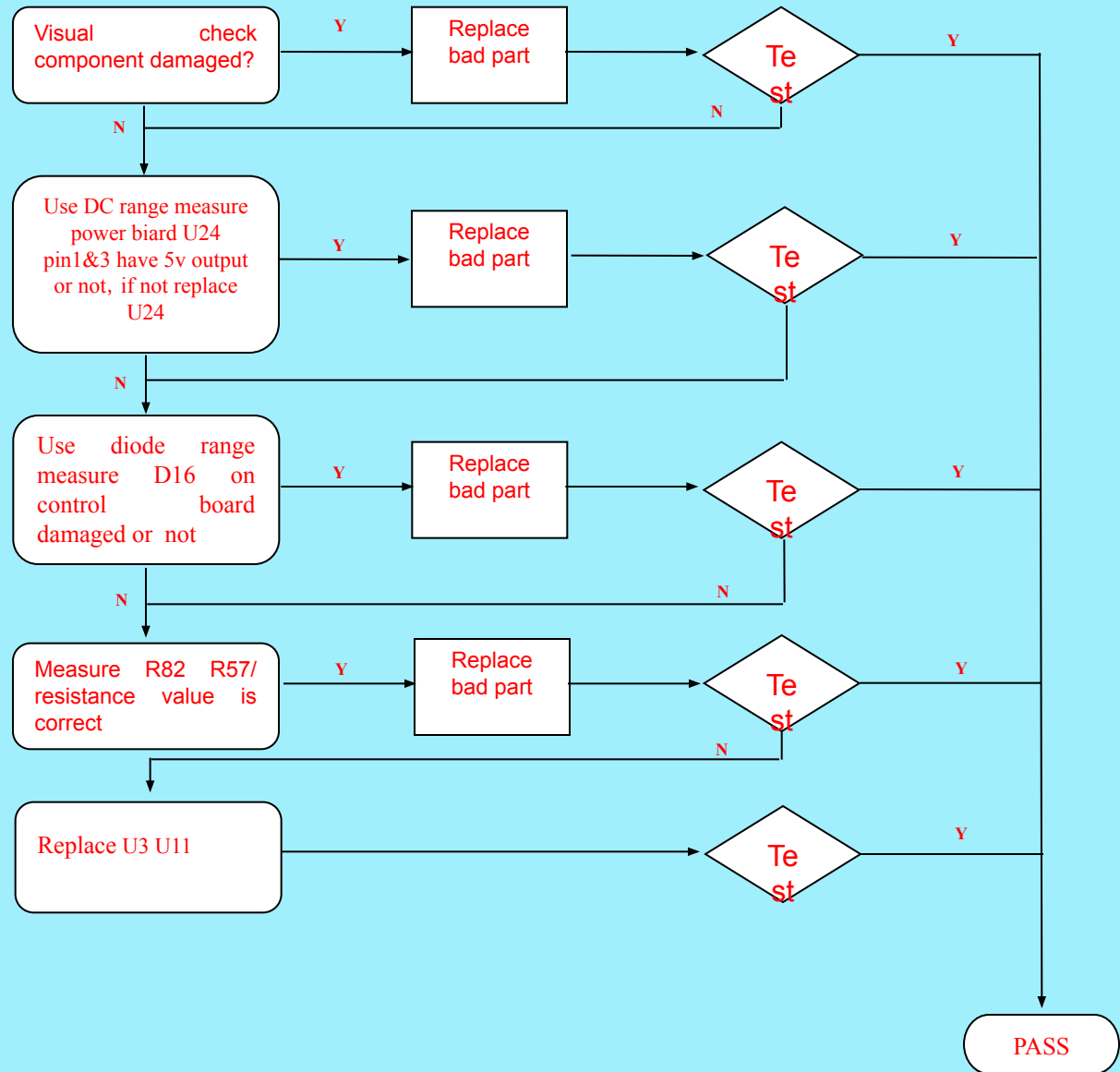

Reverse side



Positive



