

FUELING

PLACING ORGANS OF OPERATING AND CONTROL SYSTEM CENTRALISED FUELING

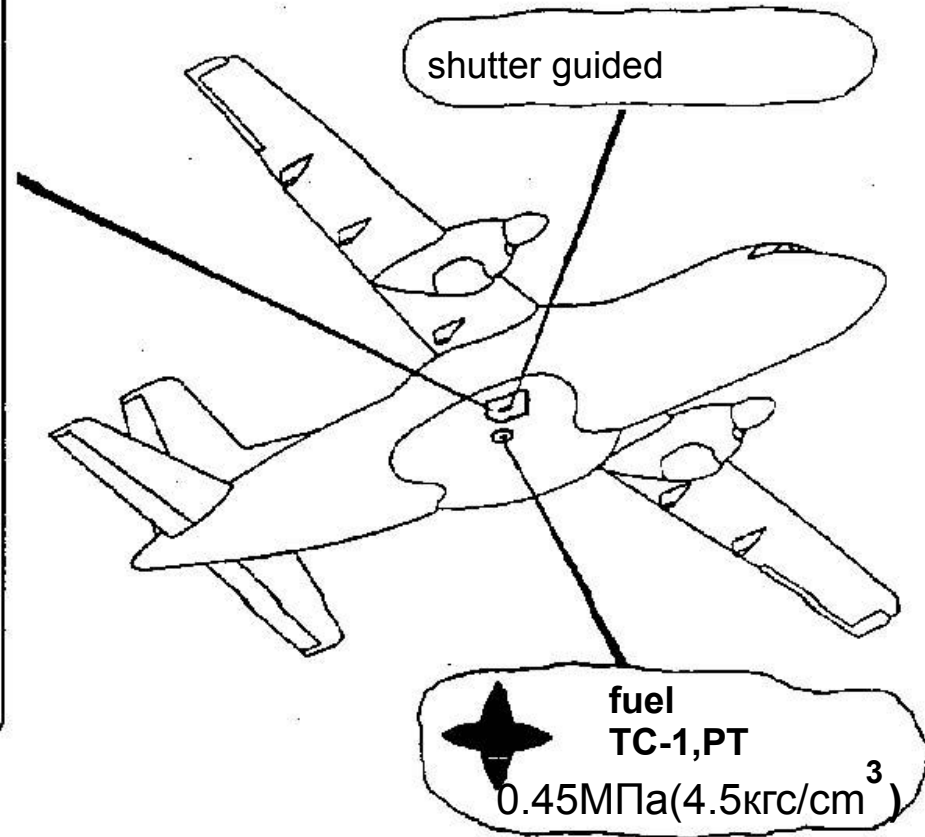
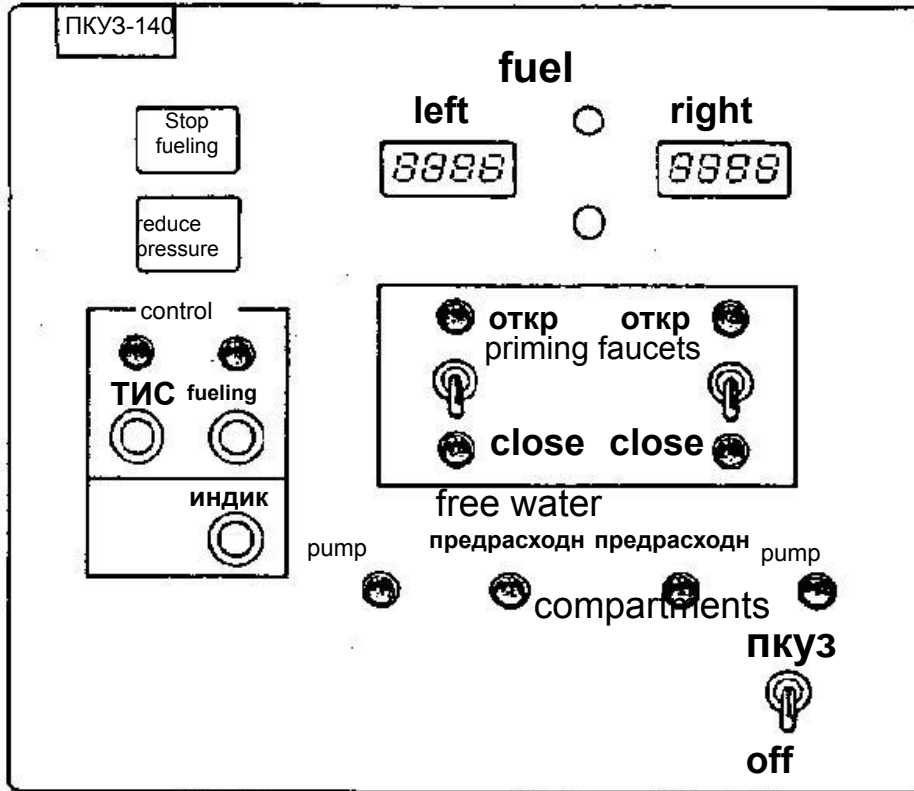

Right cowling of undercarriage

CREDIBLE PHASE TRANSITIONS of WATER In FUEL On wing AT DIFFERENT COMBINATIONS of TEMPERATURE, HUMIDITY of AIR, SIZES of DROPS of MOISTURE

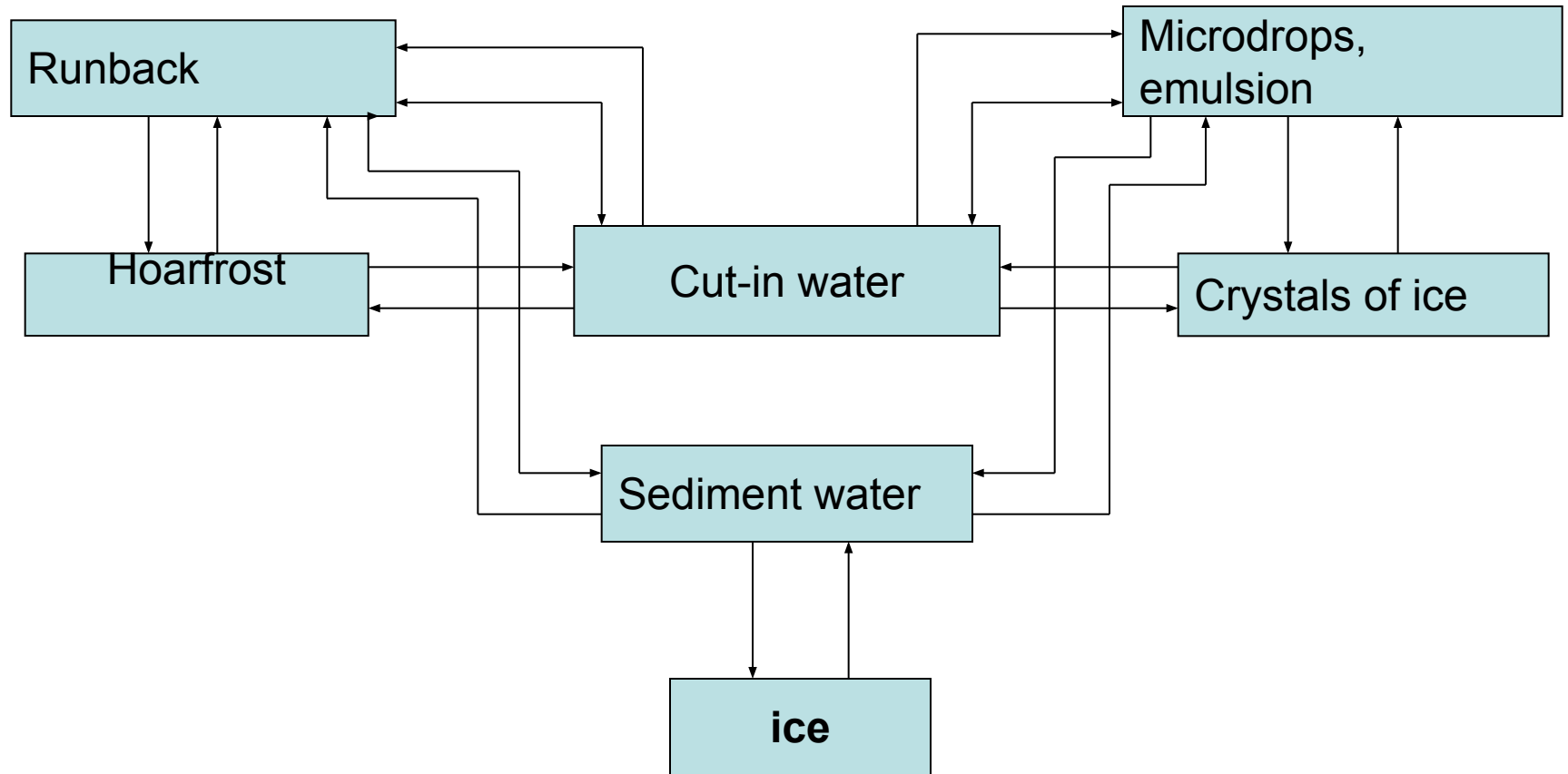

Protractor for elevator and ailerons

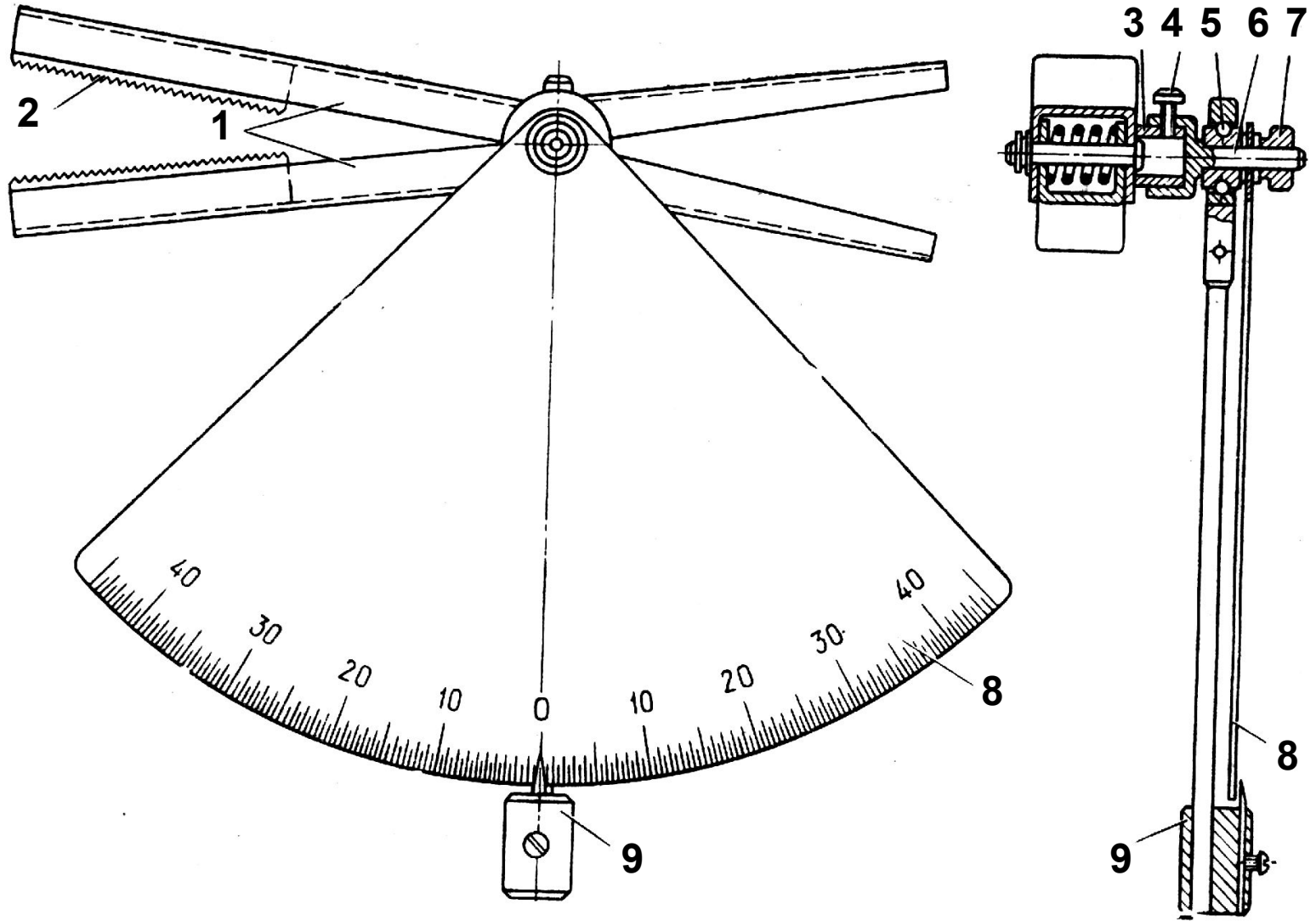

1 - lever champing jaw; 2 - vice jaws; 3 - sleeve; 4 - screw; 5 - ball bearing; 6 - axis;
7 - nut; 8 - instrument scales; 9 - plumb bob

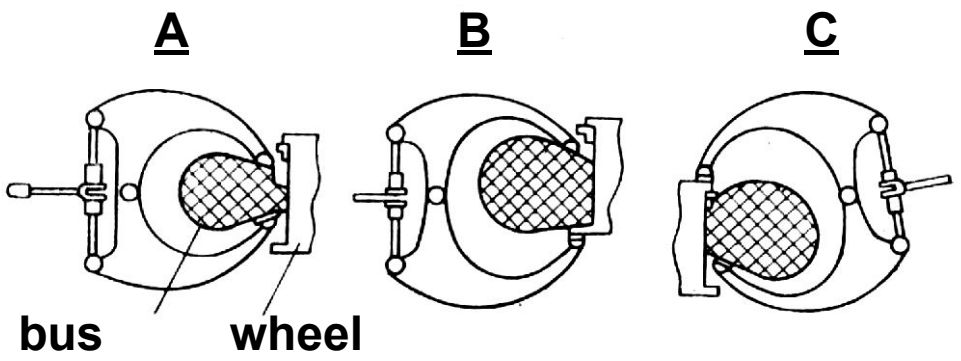
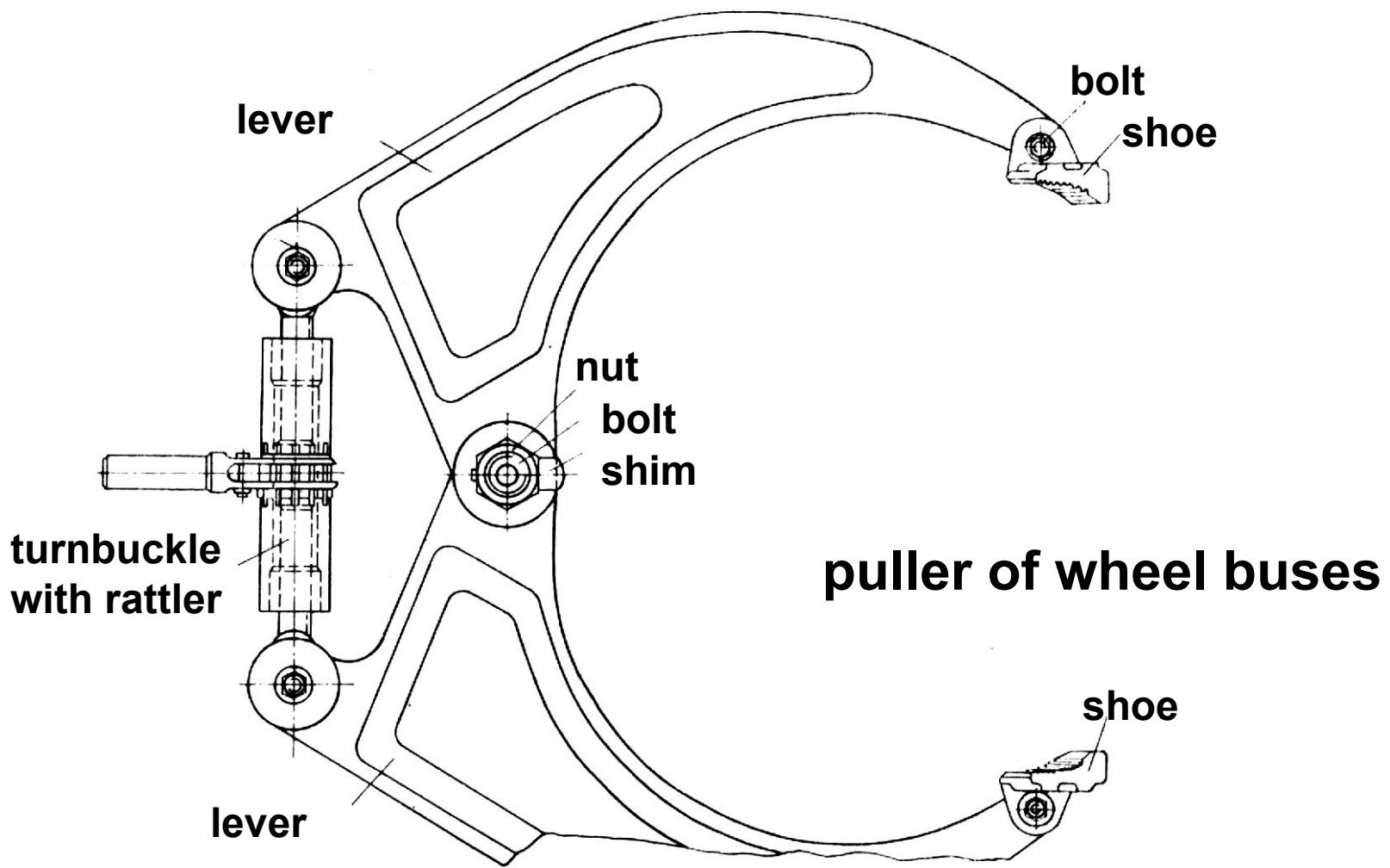

SUPPORT FOR AIR SCREW

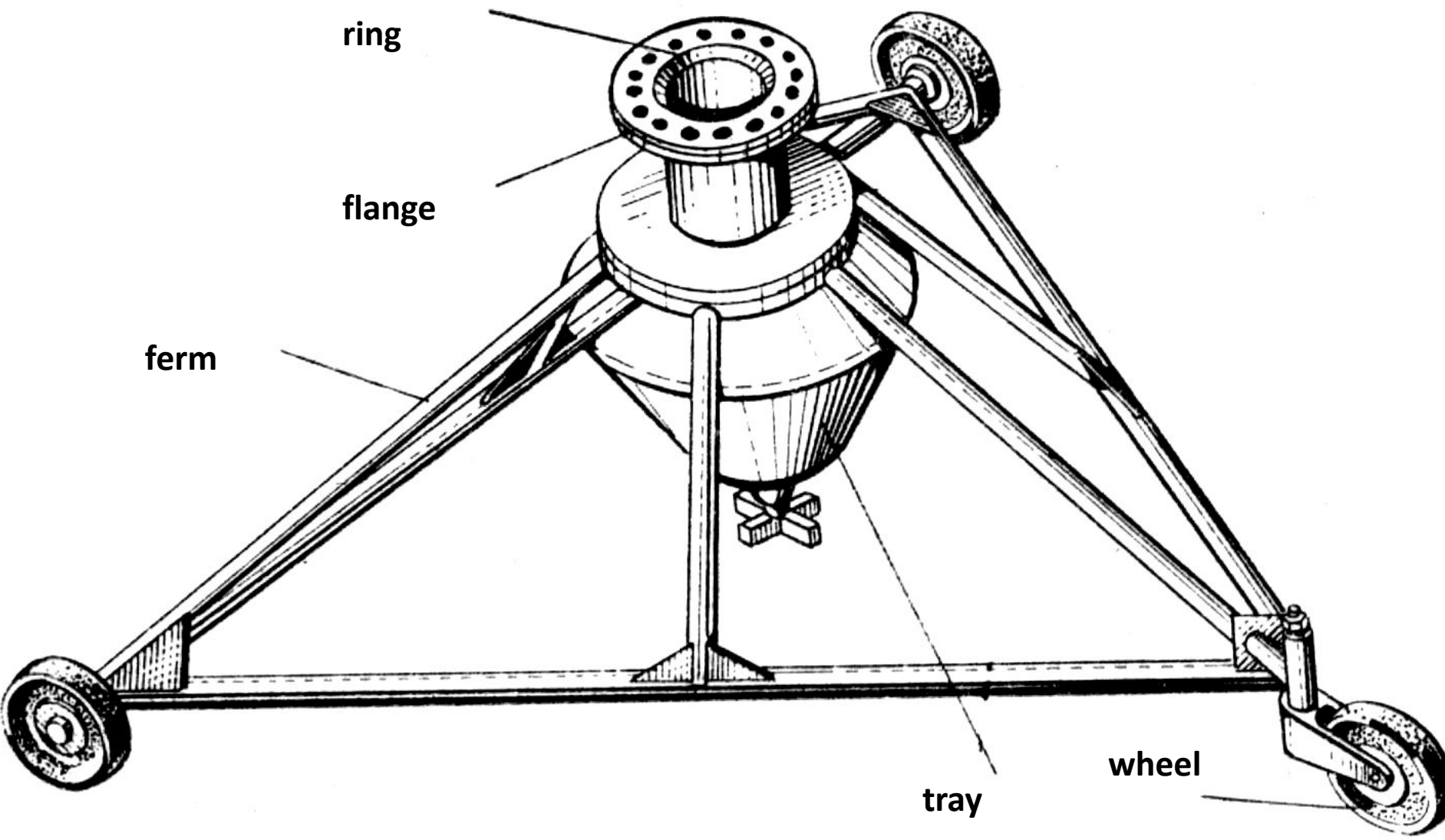

ring

flange

ferm

tray

wheel

Traverse for lifting the engine

