

Урок по швейному делу



Выполнил учитель Коновалова Г.А.

«Благовещенская специальная (коррекционная) общеобразовательная школа-интернат VIII вида».

Пословица

«Труд человека кормит, а
лень портит»



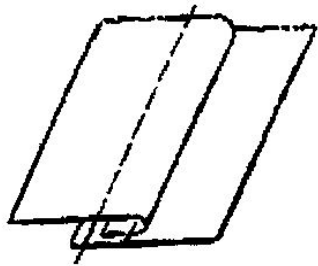

1

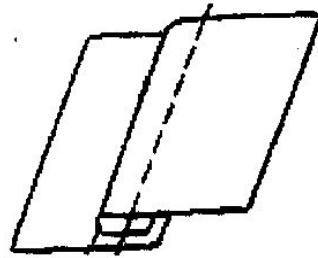

2

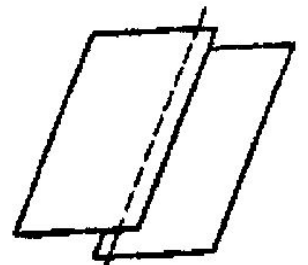

3

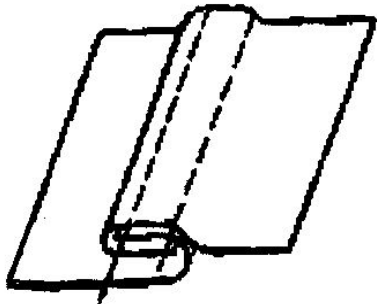

4

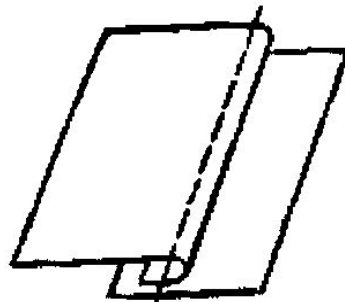

5

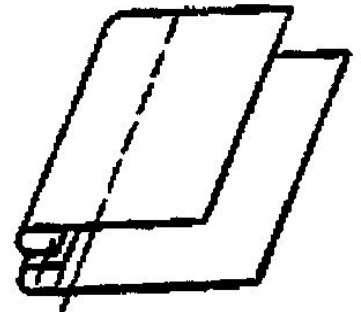

6

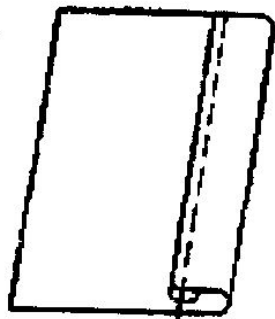

7

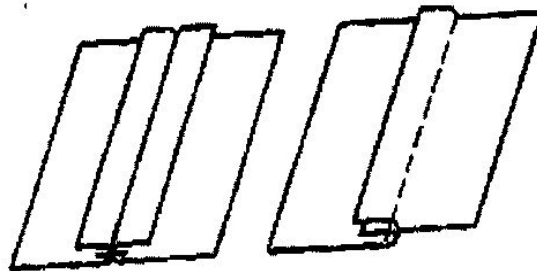

8

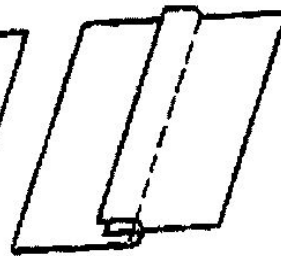

9

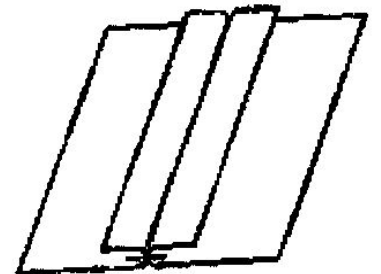

10

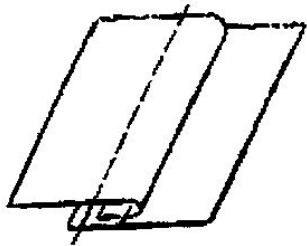

1

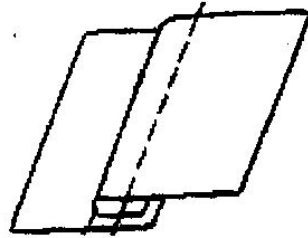

2

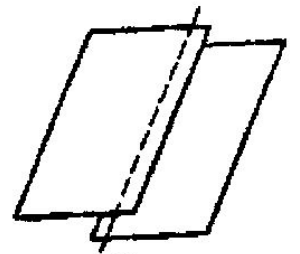

3

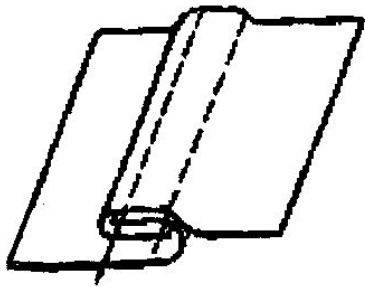

4

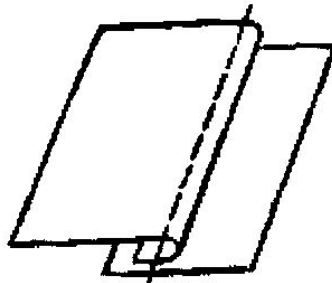

5

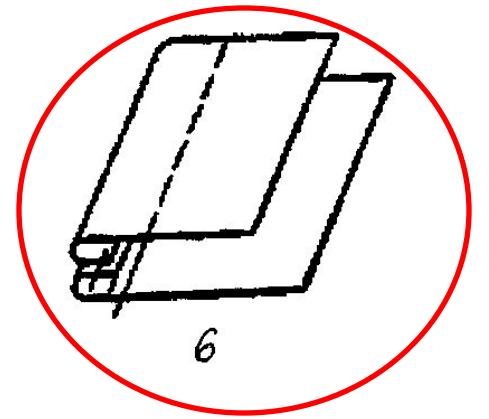

6

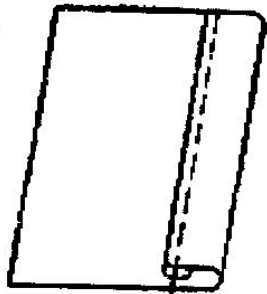

7

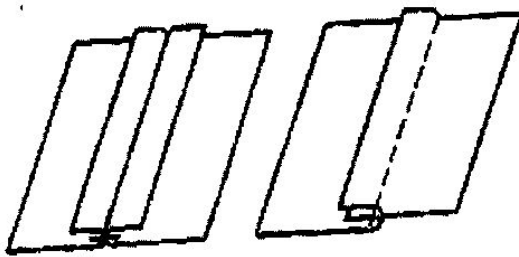

8

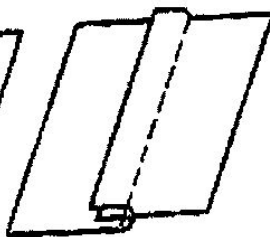

9

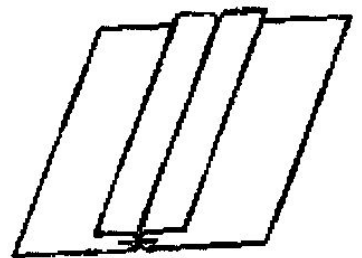

10

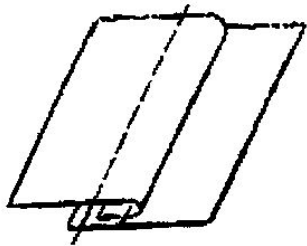

1

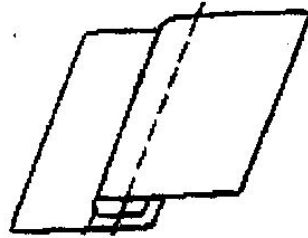

2

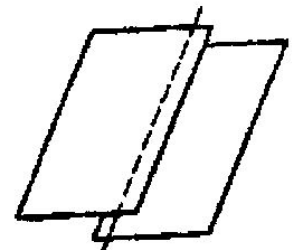

3

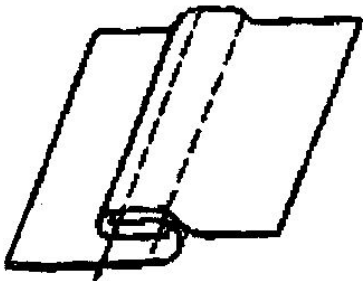

4

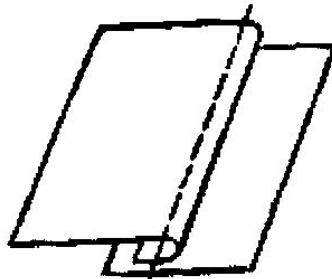

5

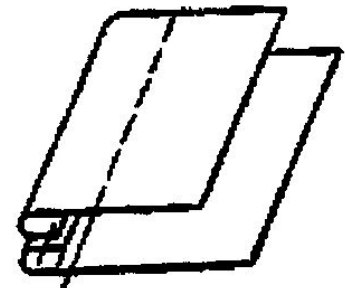

6

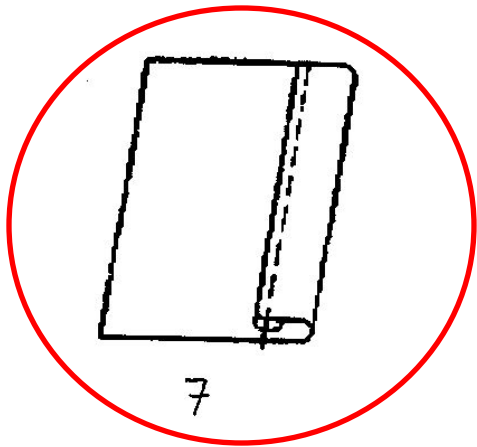

7

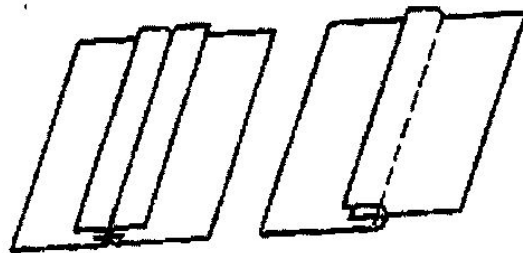

8

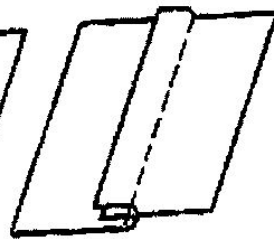

9

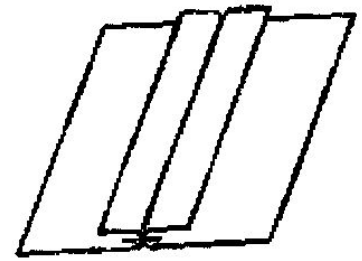

10

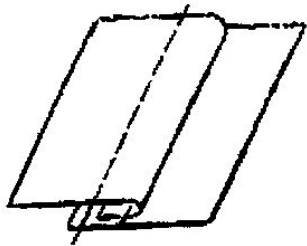

1

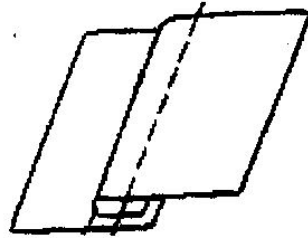

2

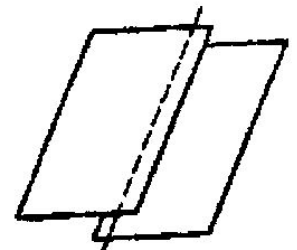

3

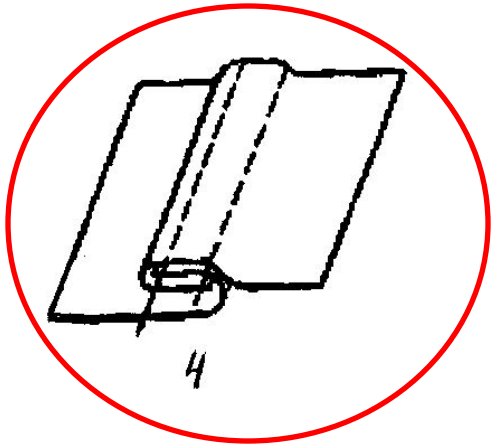

4

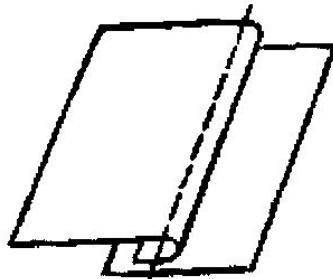

5

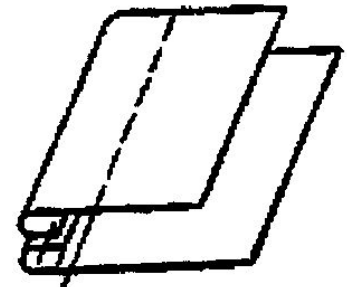

6

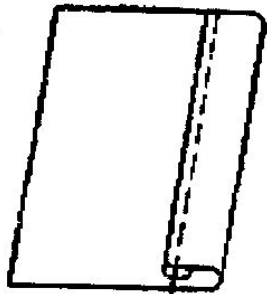

7

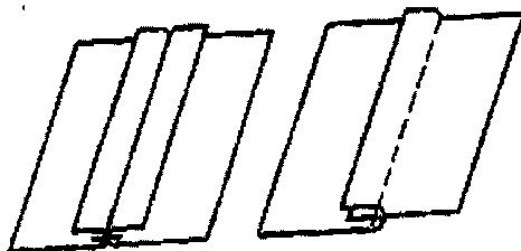

8

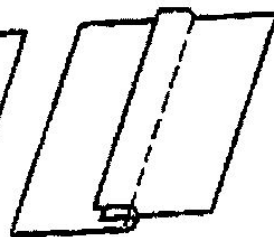

9

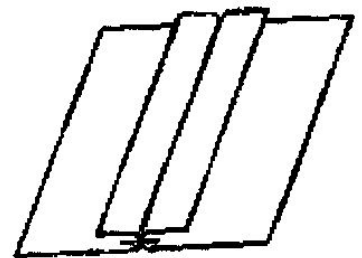

10

Тема урока:
Соединение боковых срезов
пижамной сорочки
запошивочным швом

Словарные слова

ПИЖА́МА

БО́КОВОЙ СРЕ́З

ЗАПО́ШИВОЧНЫЙ ШОВ

Тема урока:
Соединение боковых срезов
пижамной сорочки
запошивочным швом



Запошивочный шов

Физминутка

Чтобы сильной стать и ловкой,
Приступаем к тренировке.
Носом вдох, а выдох ртом.
Дышим глубже, а потом,
Шаг на месте, не спеша.
Как погода - хороша!
Мы проверили осанку,
И свели лопатки.
Мы походим на носках,
А потом на пятках.



Тема урока:
Соединение боковых срезов
пижамной сорочки
запошивочным швом

Какие инструменты необходимы для пошива пижамы?

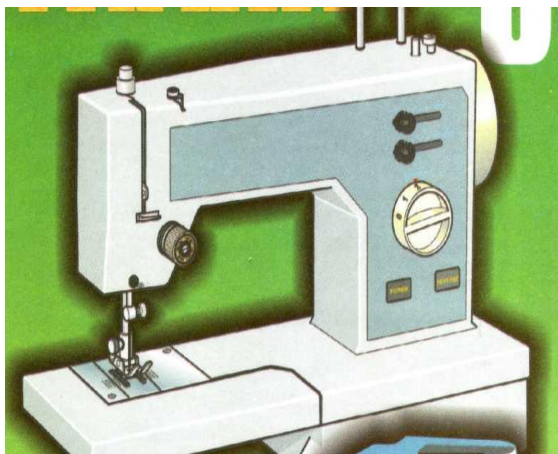
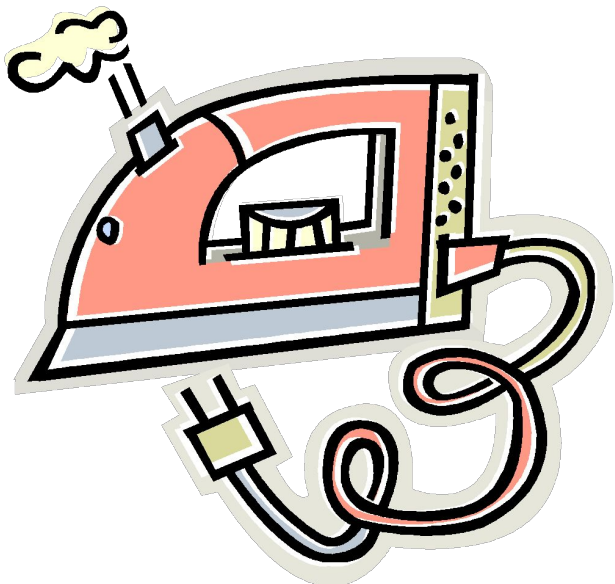

Практическая работа

**Обработка боковых срезов
пижамной сорочки
запошивочным швом**

Технологическая карта

7-9 мм

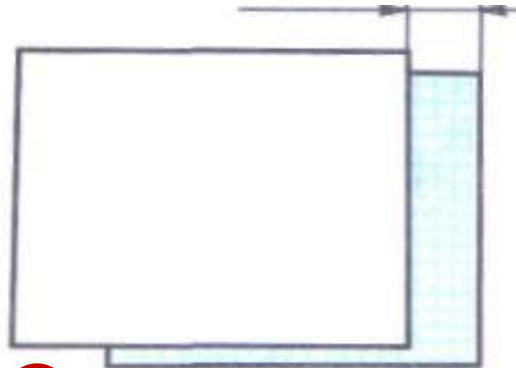

①

5-7 мм

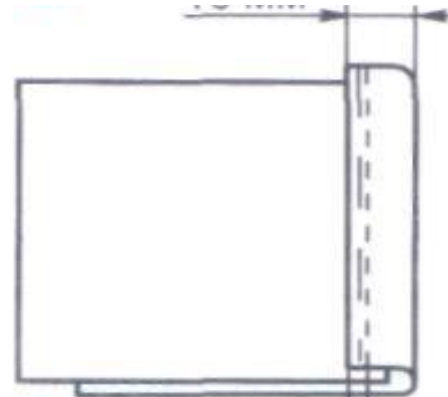

②

2-3 мм

1-2 мм

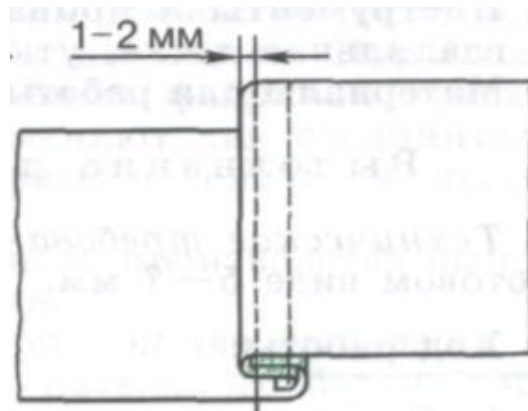

③

④

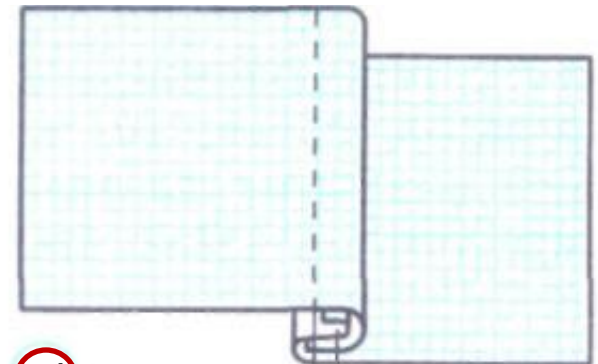



Практическая работа

**Обработка боковых срезов
пижамной сорочки
запошивочным швом**

Технологическая карта

7-9 мм

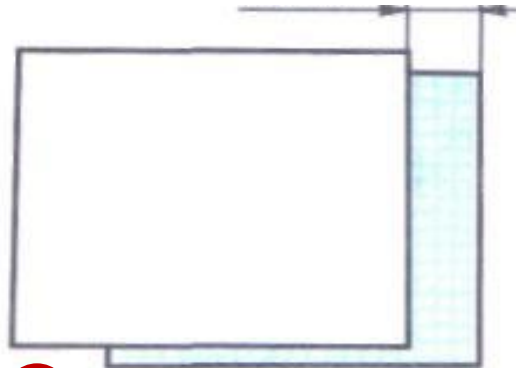

①

5-7 мм

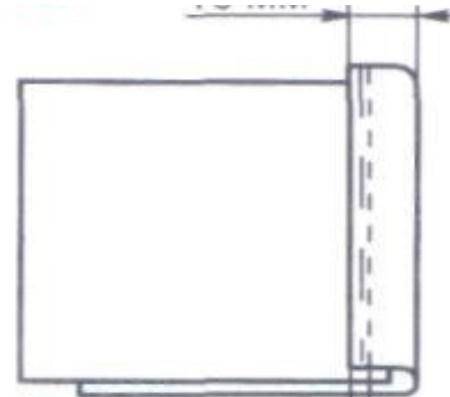

②

2-3 мм

1-2 мм

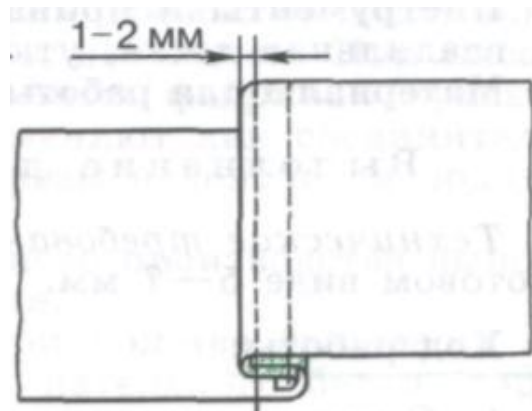

③

④

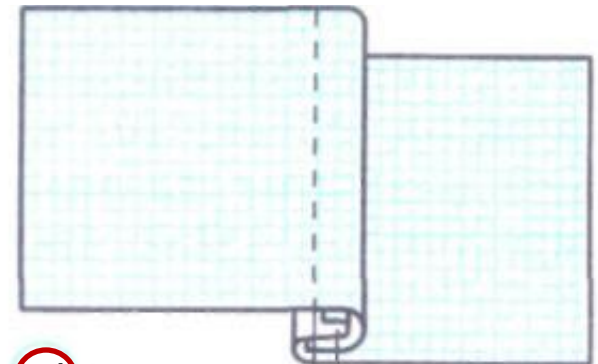

Проверка качества работы

1. Ширина шва равна 7мм.
2. Строчка ровная, проложена точно по краю подгиба.
3. На лицевой стороне нет слабину ткани в шве.
4. Шов хорошо приутюжен.

Спасибо за работу