

Air Treatment system



Air Treatment system

The air treatment system must ensure:

- Filling the air system with compressed air (compressor) within the set filling time
- Cleaning the compressed air (unloader valve , air dryer)
- Controlling the operating pressure (unloader valve)
- Protection of the air system against freezing (alcohol injector, air dryer)
- Removing the water that got into the system (manual or automatic drain valve)

Furthermore:

- The circuits of the system are protected from each other
- In the case of the failure of a circuit, the system must remain chargeable
- The capacity of energy storage must be sufficient to:

In the case of motor vehicles that the requirements regarding the safety brake (braking performance) be fulfilled at the time of the ninth braking after 8 full brakes.

In the case of trailers, at the time of the ninth braking after 8 full brakes the braking performance cannot be less than the half of the braking performance measured at the first braking.

- The warning system must give a warning at the time of a 5th braking after 4 full brakes with the service brake circuit.



Air treatment system

In the case of an air dryer equipped with integrated unloader valve

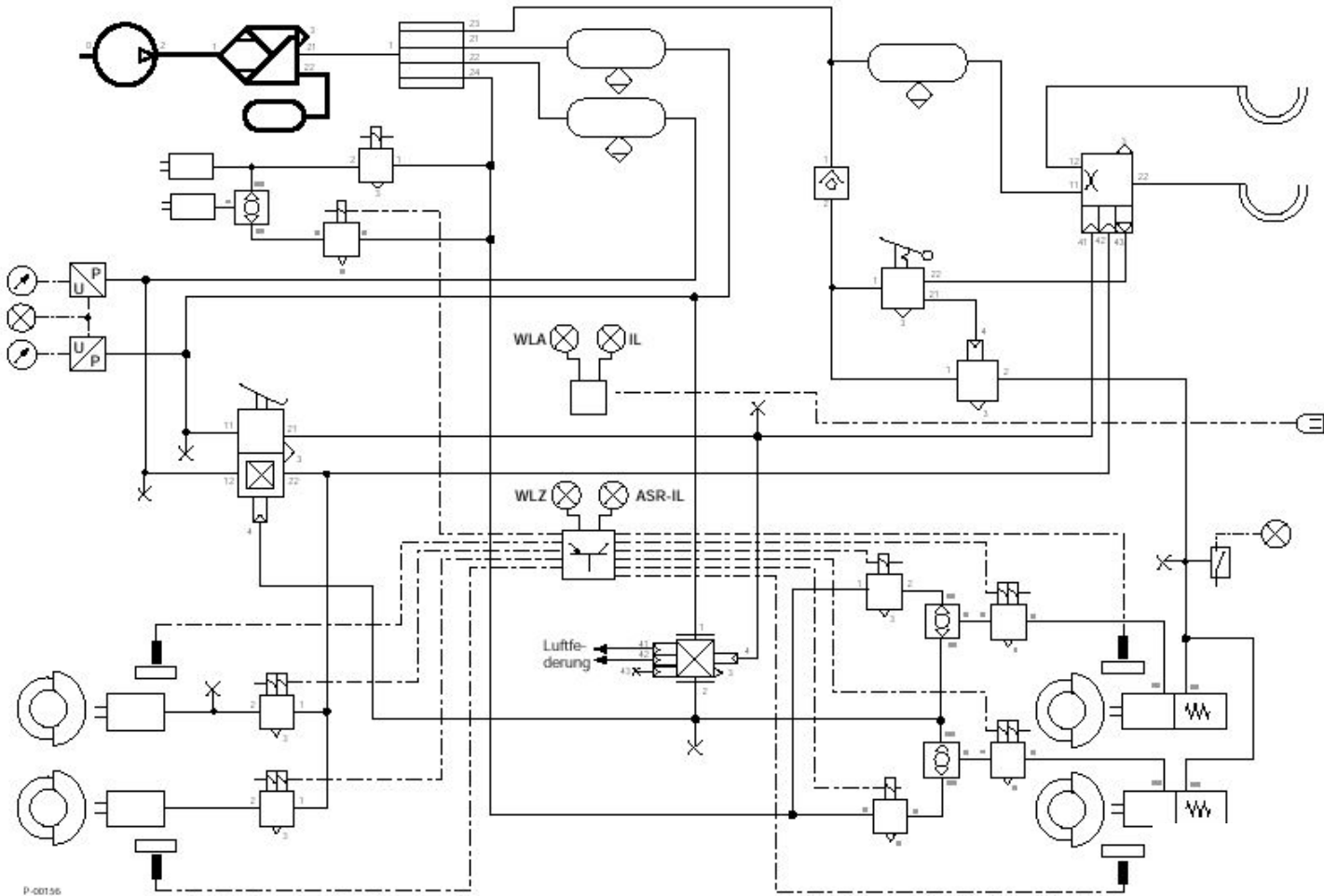

In the case of an air dryer not equipped with integrated unloader valve

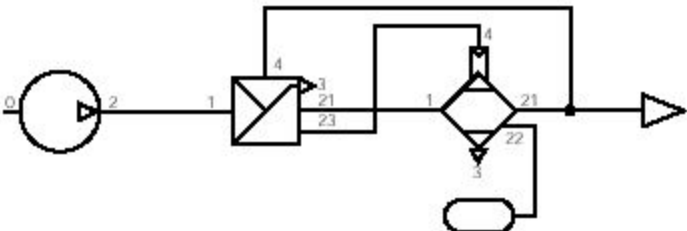

Air treatment system

Delivery phase

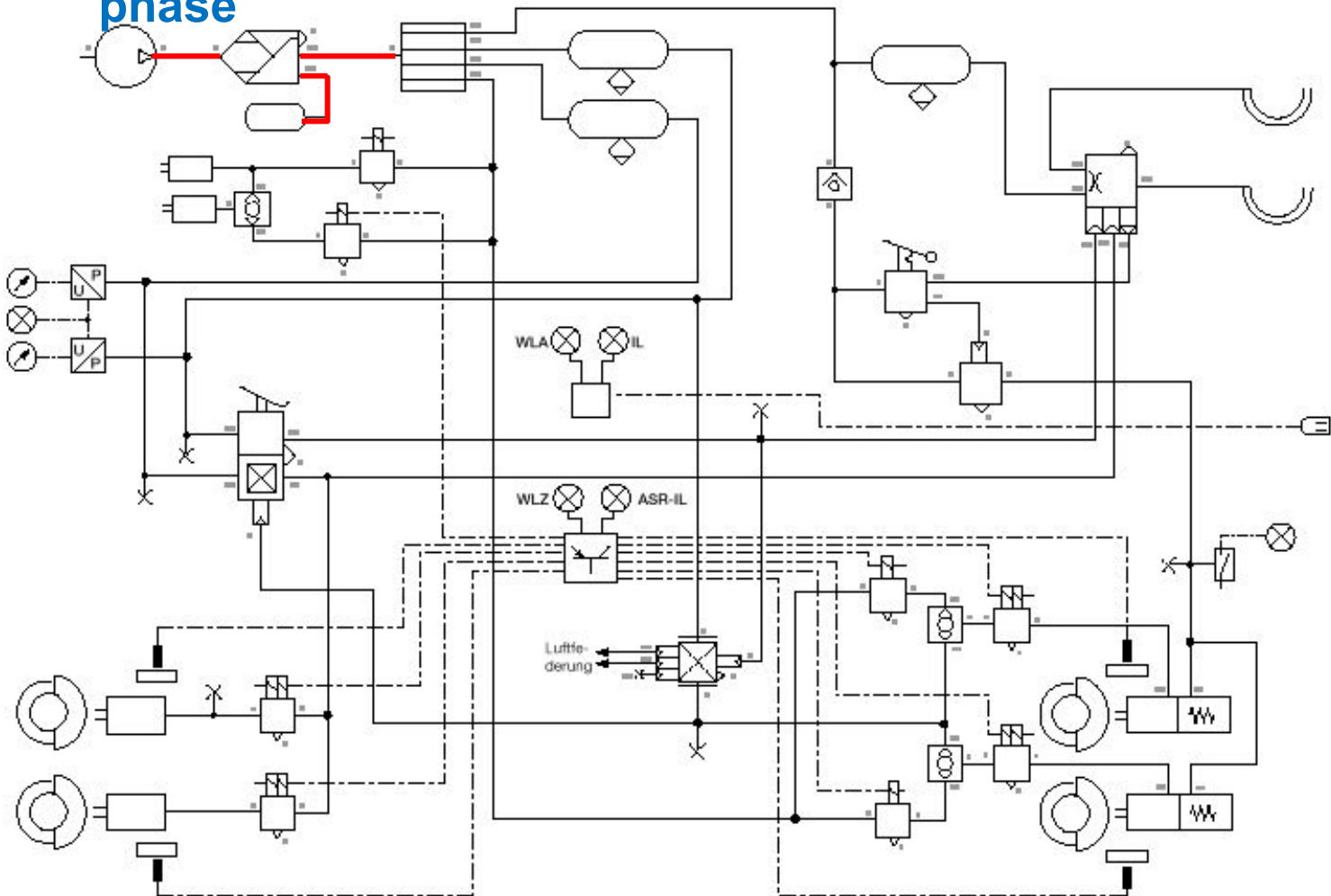

Air treatment system

End of regeneration phase

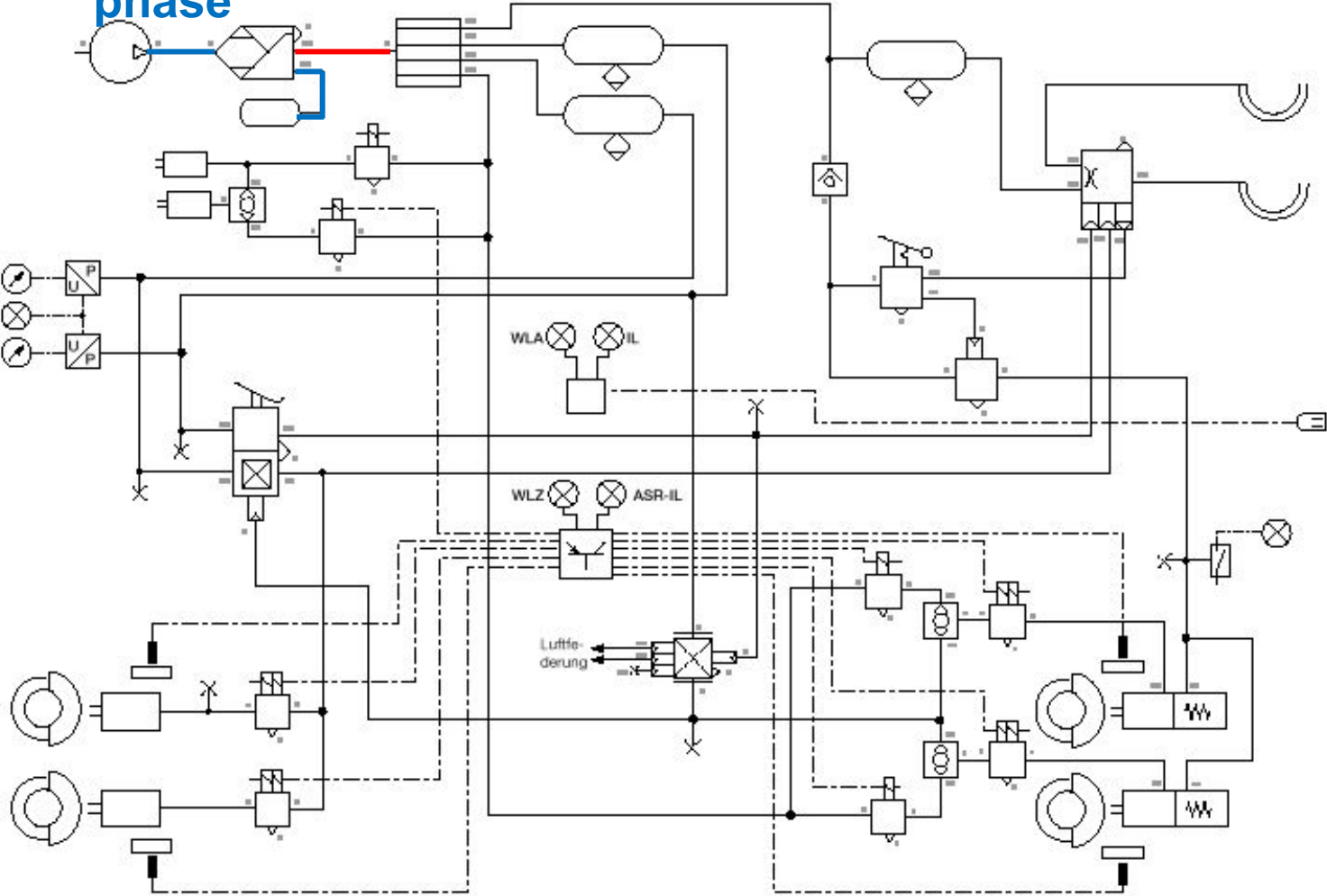

Air treatment system

Installation environment of the air treatment system. What do you have to pay attention to during service activities?

- Installation environment of the air treatment components,
- Structure of the compressor drive,
- Solutions for the heating and lubricating of the compressor,
- Decrease of the temperature of the delivered (compressed) air,
- Installation of the appropriate air treatment components.

The proposed size of suction pipes and pressure tubes is 18x1.5, the length of the suction pipe preferably should not exceed 1 m.

In the case of a force-feed oil-lubricated compressor, the maximum oil temperature is 130°C and the minimum oil pressure is 0.5 bar.

Interface between the engine and the chassis

Maximum inlet air temperature is 65°C

Engine

Gear

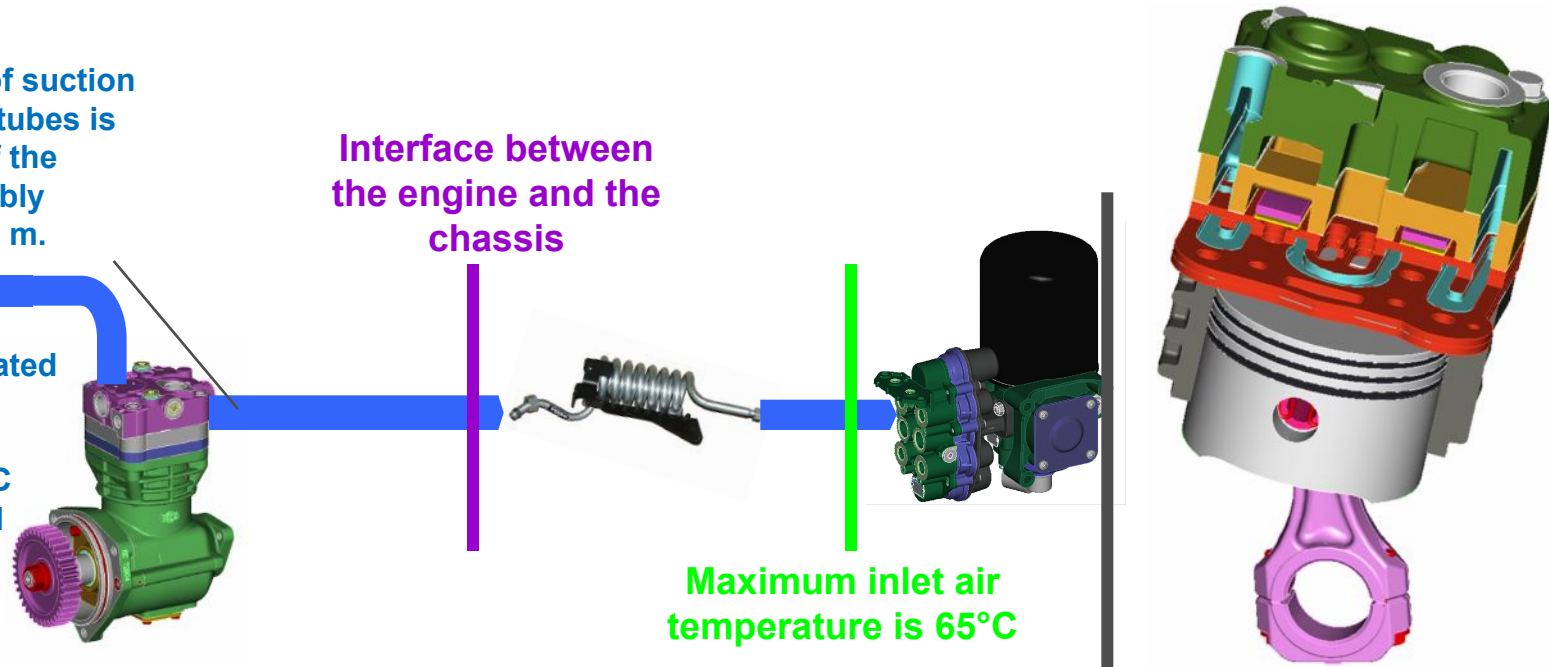

Air treatment system

Technological development of compressors

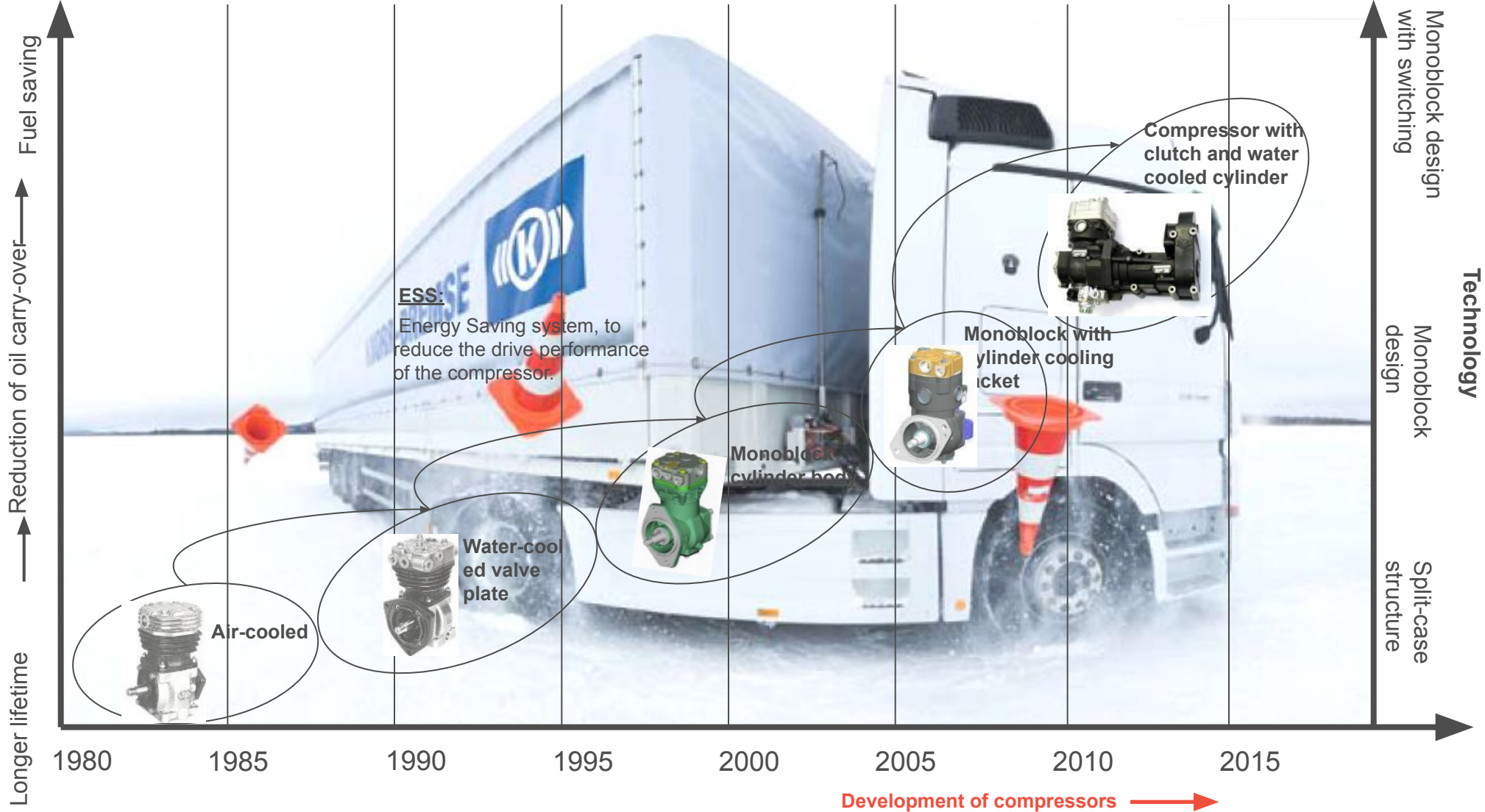

Air treatment system

Compressor (LP1...; LK1...; LP3...; LK3...; ACX6...; ACX7...; ACX8...; KZ3...;KZ4...)

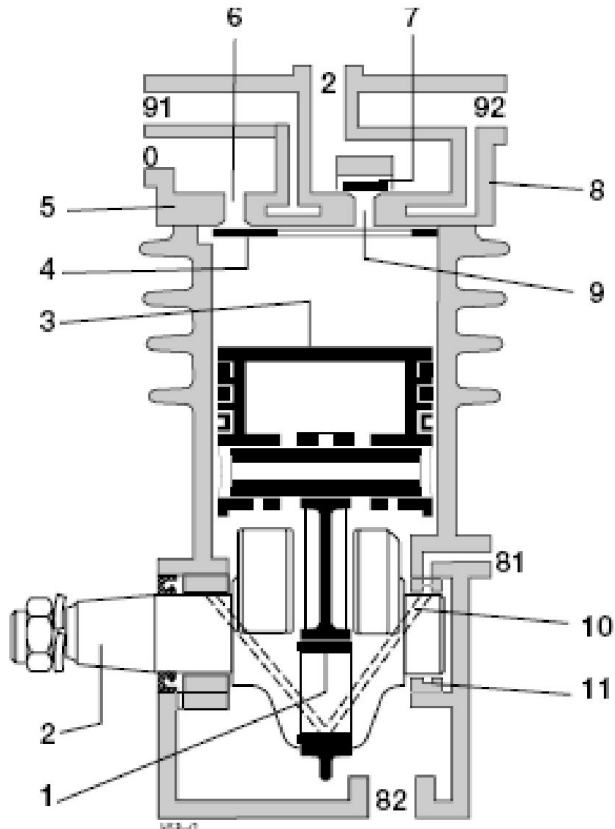

Components:

- 1 Connecting rod bearing
- 2 Crankshaft
- 3 Piston
- 4 Inlet reed
- 5 Valve plate
- 6 Inlet hole
- 7 Compression reed
- 8 Cylinder head
- 9 Outlet hole
- 10 Oil channel
- 11 Plain bearing

Types:

- 1 or 2-cylinder
- Drive by V-belt or gear wheel
- Air or water-cooled
- Normal or ESS function
- Independent or integrated into the engine
- Own lubrication or lubrication by the engine

Warning for the installation:

The compressor has to be installed in such a way that its appropriate cooling is ensured. The revolution of the compressor and the cooling solution have to be synchronised in such a way that the temperature of the outflowing air do not exceed 220°C, not even during forced operation. In the case of V-belt drive, an adjustment option must be provided at the tension roller of the V-belt.

Air treatment system

Suction phase

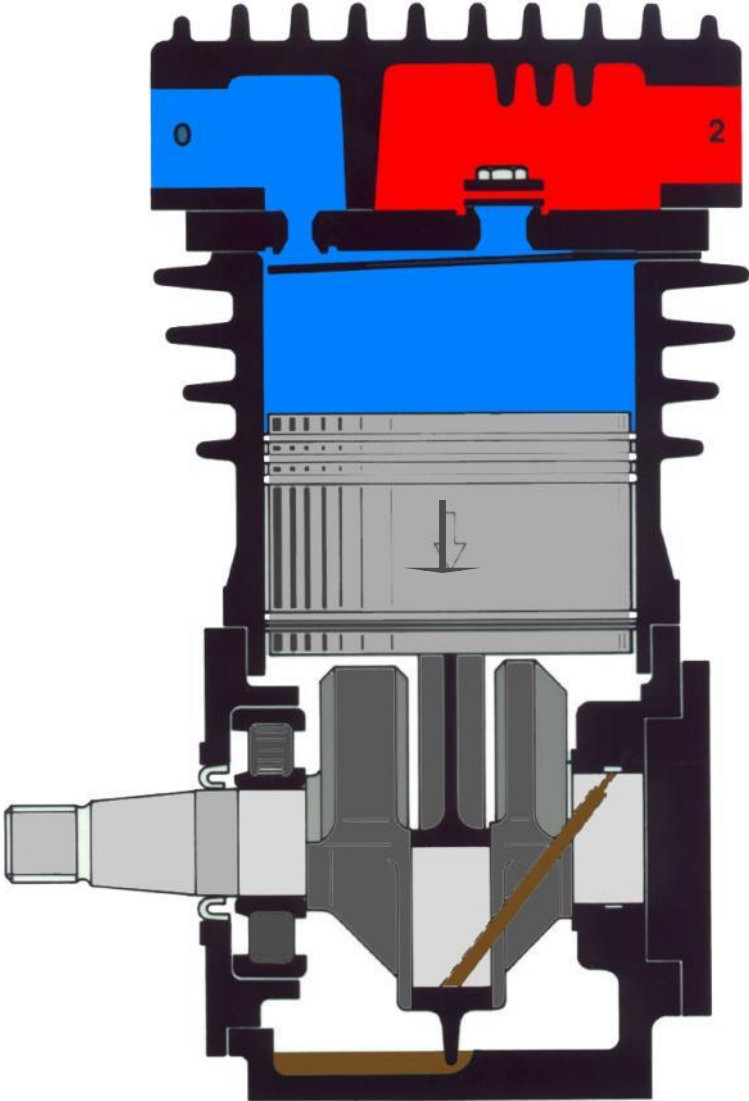

Delivery phase

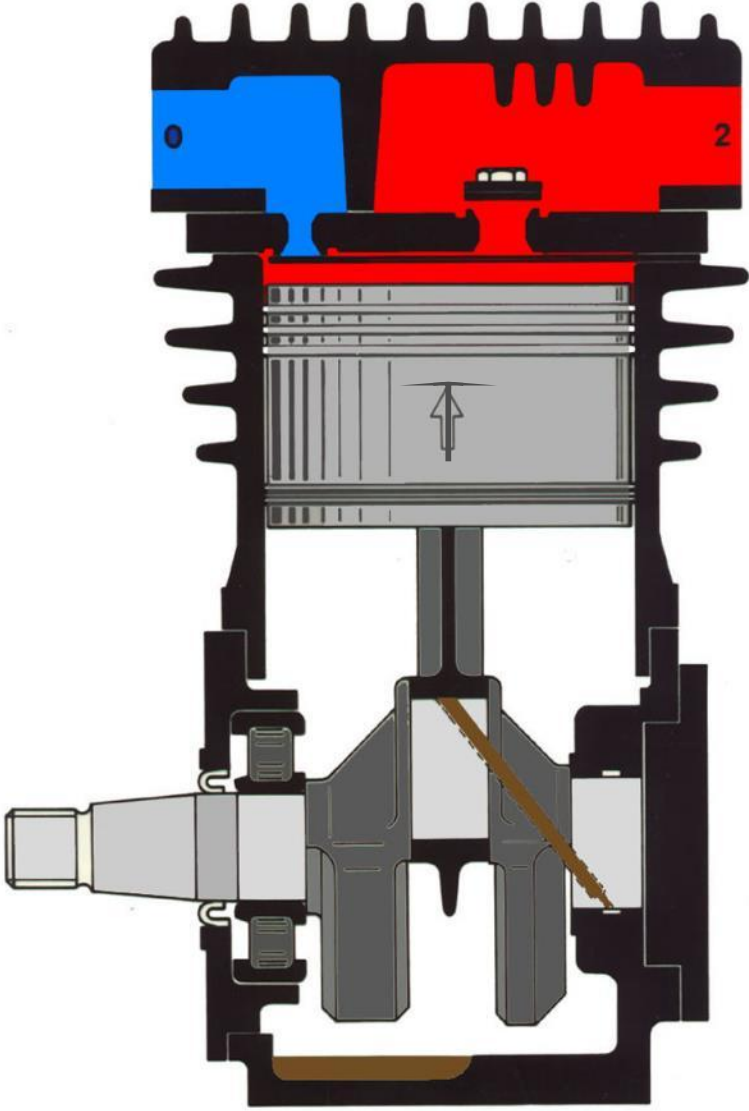

Overview of the compressors

North America

**Tu-Flo 550™ &
Tu-Flo 750™
70 mm piston**

**300 cc & 370 cc
twin cylinder**

**Turbocharged
Version available**



**BA-921™
92 mm
piston**

**Turbocharge
version
available**

**360 cc
single
cylinder**



**BA-922™
92 mm
piston**

**720 cc
twin
cylinder**



European products

80 mm piston

**225 cc
single
cylinder**



**86 mm
piston**

**460 –
720 cc
twin
cylinder**



92 mm piston

**360 cc
single
cylinder**



**92 mm
piston**

**650 –
720 cc
twin
cylinder**

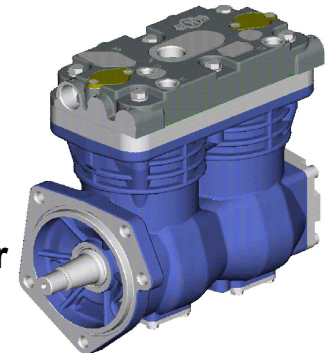

Air treatment system

ESS function

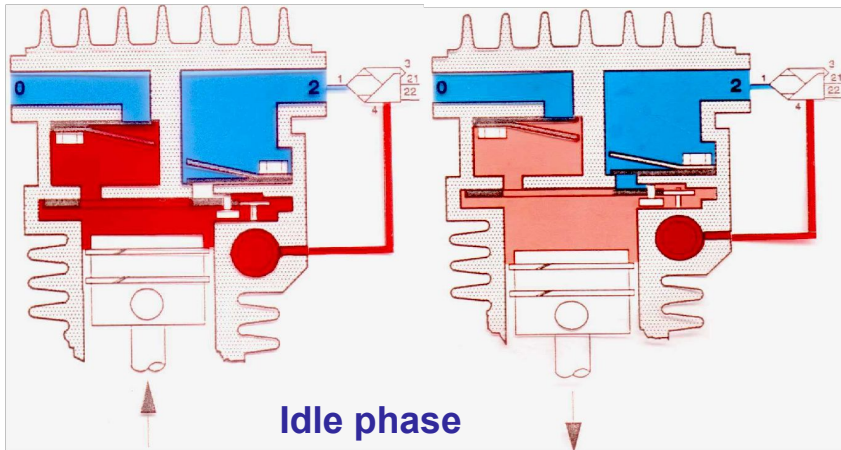
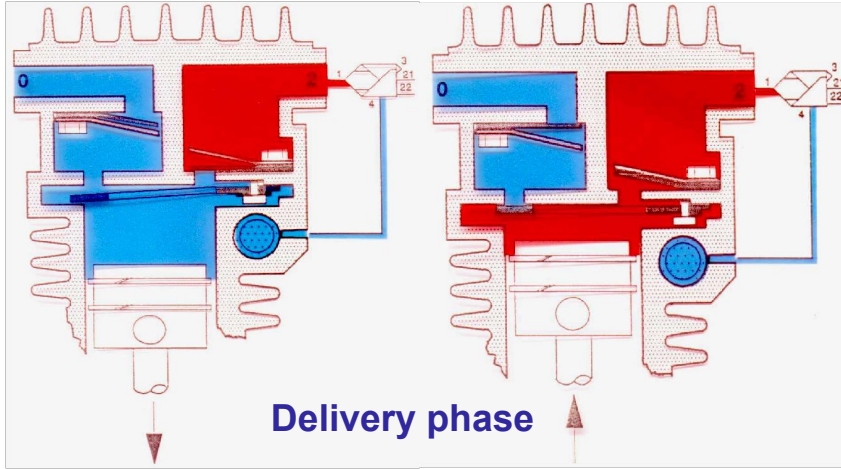

Change of cylinder head pressure in idle phase

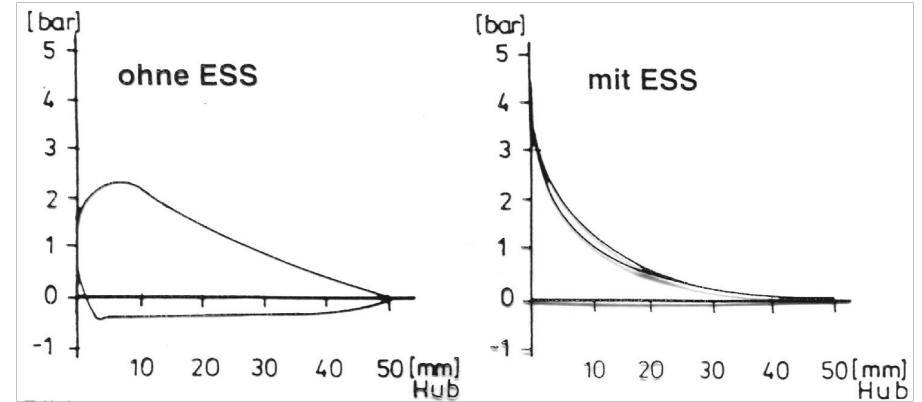

Power consumption of a 600 cc compressor in idle phase

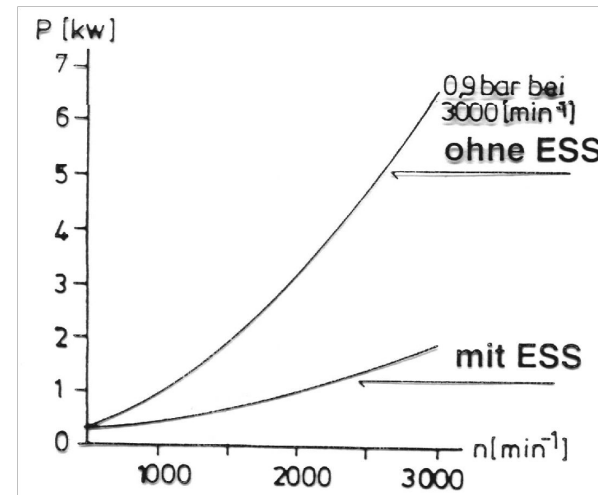

Air treatment system

New ESS structure

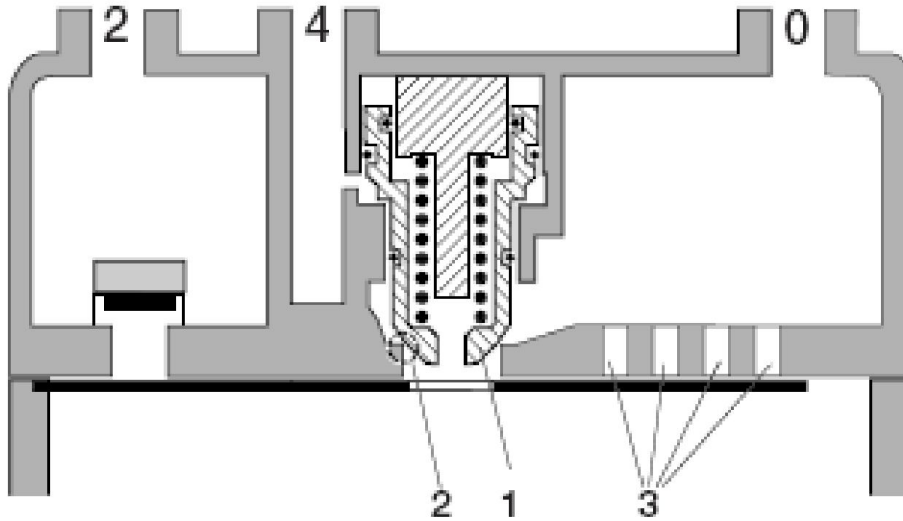

ESS is not active

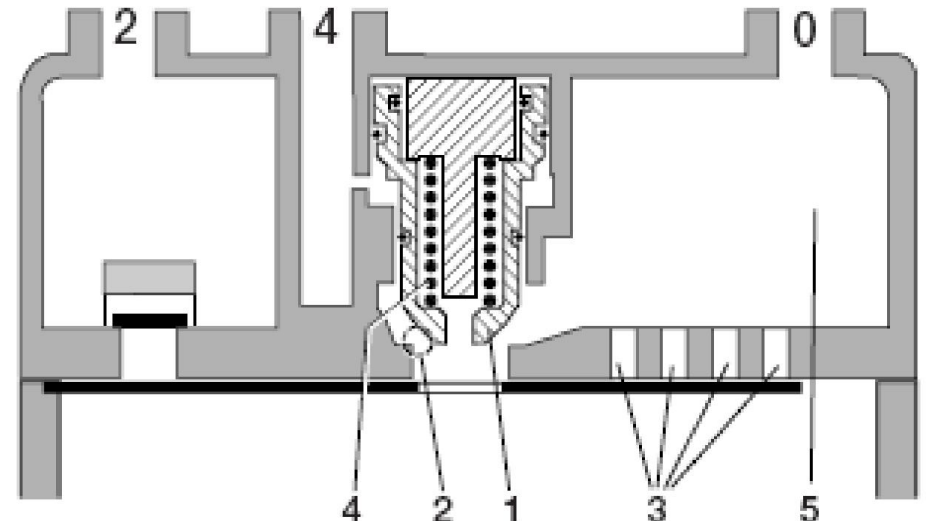

ESS function is active

- | | |
|-----------------------|-----------------------|
| 1. Valve piston | <u>Connectors:</u> |
| 2. Valve seat | 0 - Intake manifold |
| 3. Suction hole | 2 – Exhaust manifold |
| 4. Compression spring | 4 – Control connector |
| 5. Suction space | |

In the ESS phase the amount of air delivered through the exhaust manifold is reduced to about 15% of the original amount.

Air treatment system

ESS structure in the case of 1 and 2-cylinder compressors

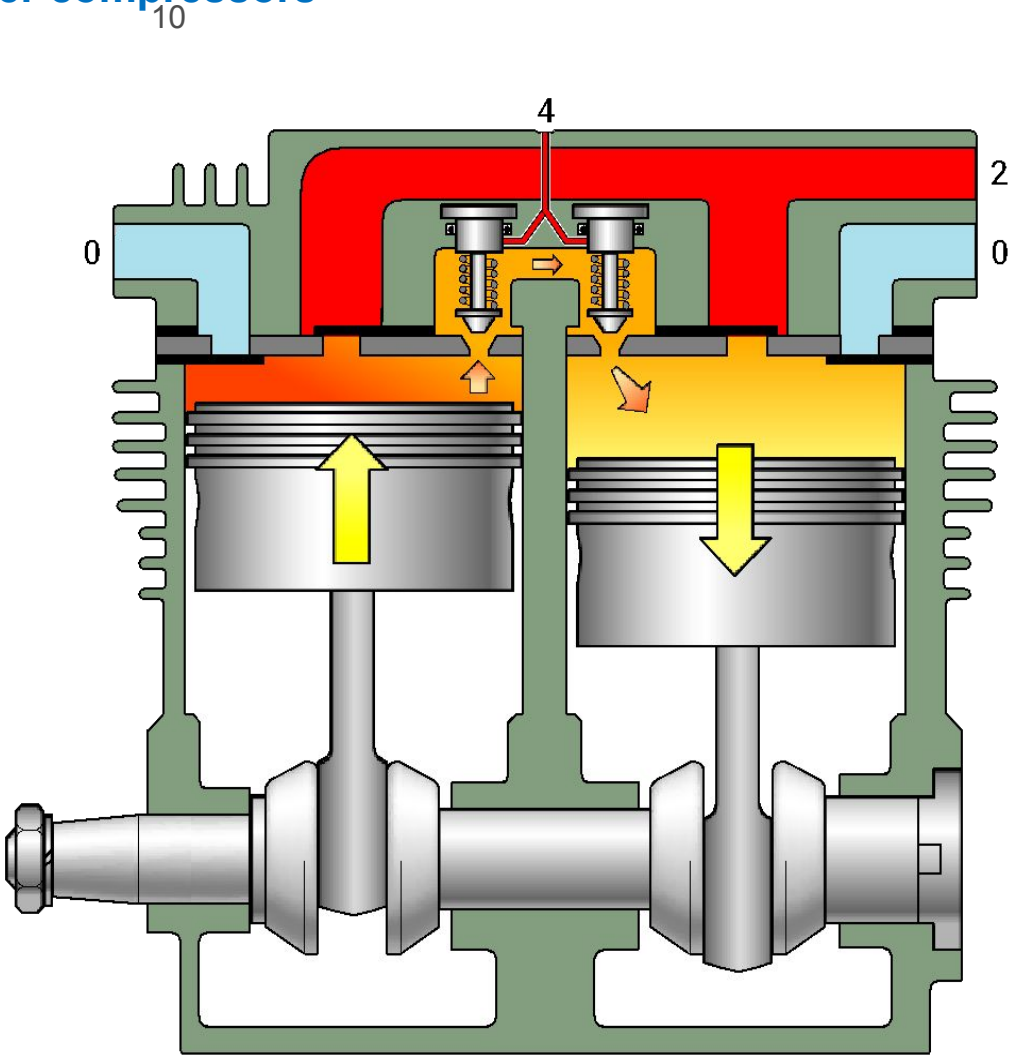
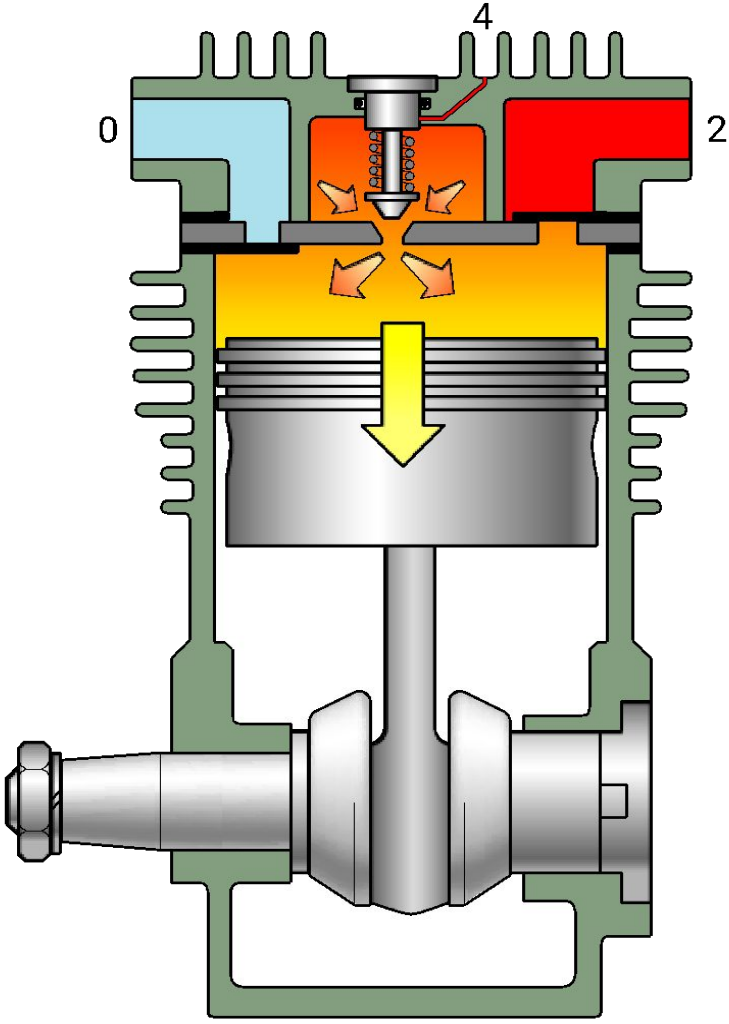

Air treatment system

Development of the cylinder head structure – Reduction of the temperature of exhausted air

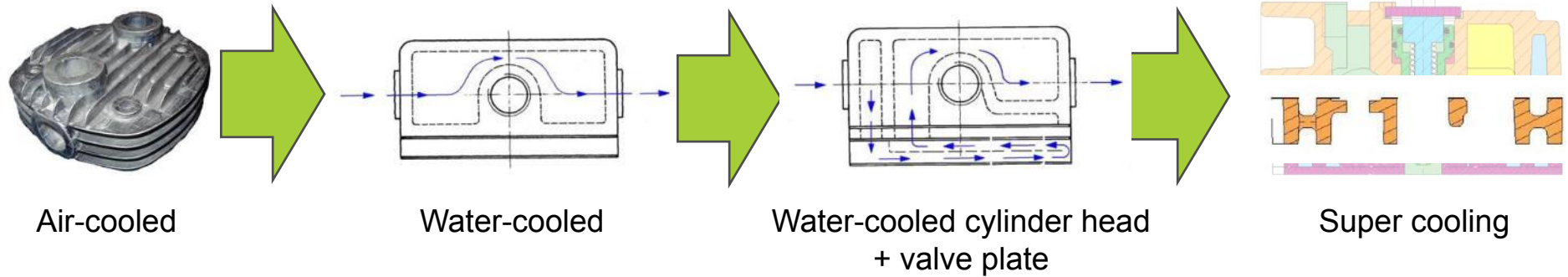

Temperature of supplied air

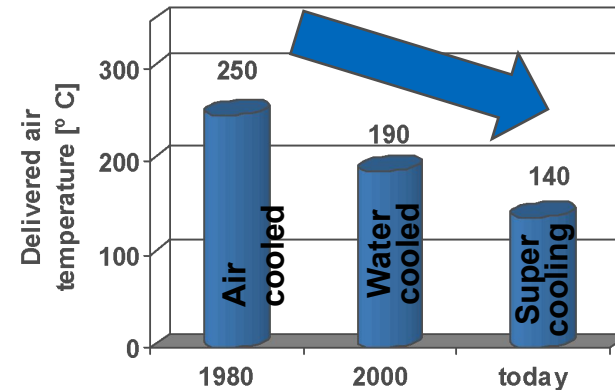

Air treatment system

Development of the crankcase – Reduction of oil carry-over

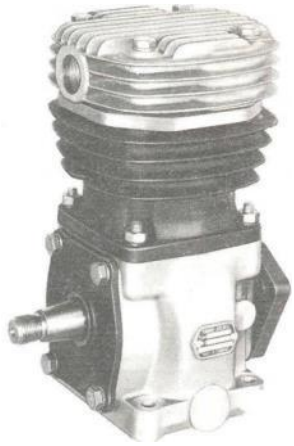

**Split-case structure,
air-cooling**

**Split-case structure,
water-cooling**

**Monoblock
design**

**Monoblock design
and cooling jacket**

**Monoblock
structure, cooling
jacket and
integrated switching**

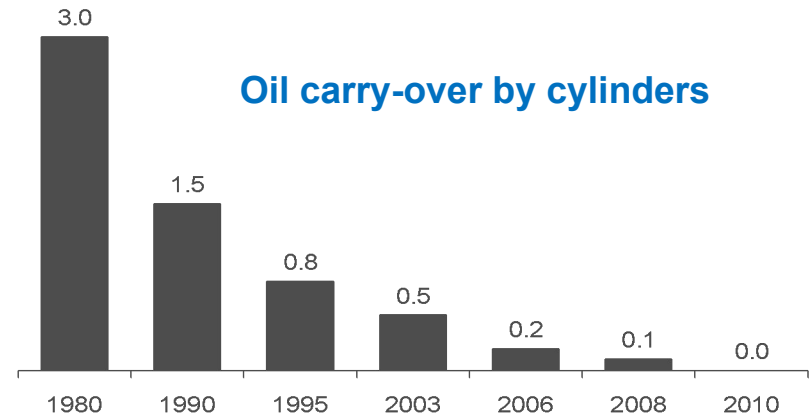
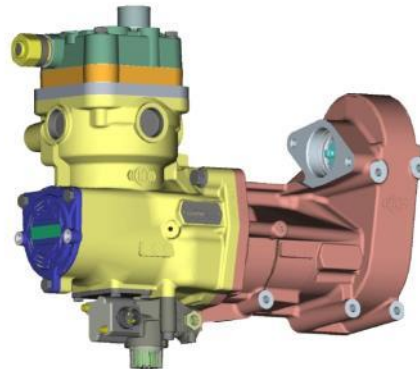

Air treatment system

Power consumption

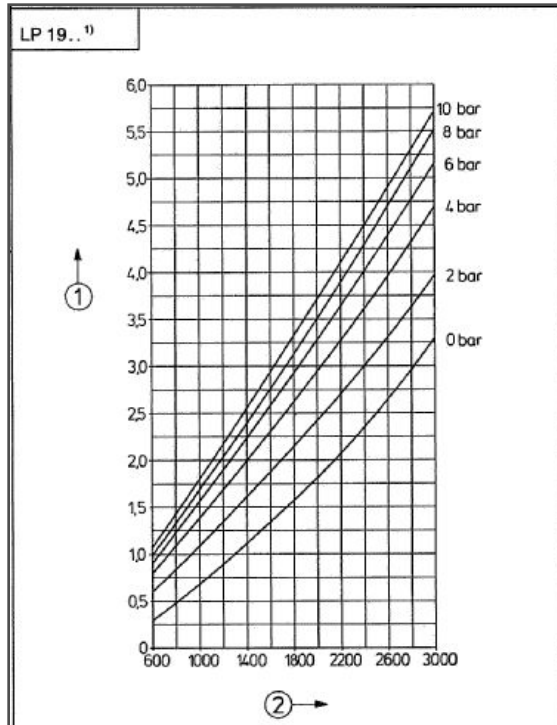

Delivery performance

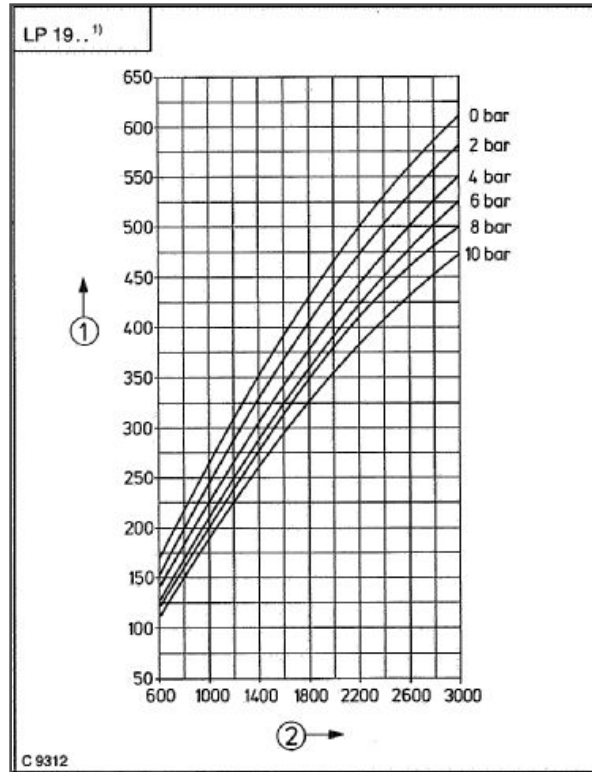

Tester for oil carry-over

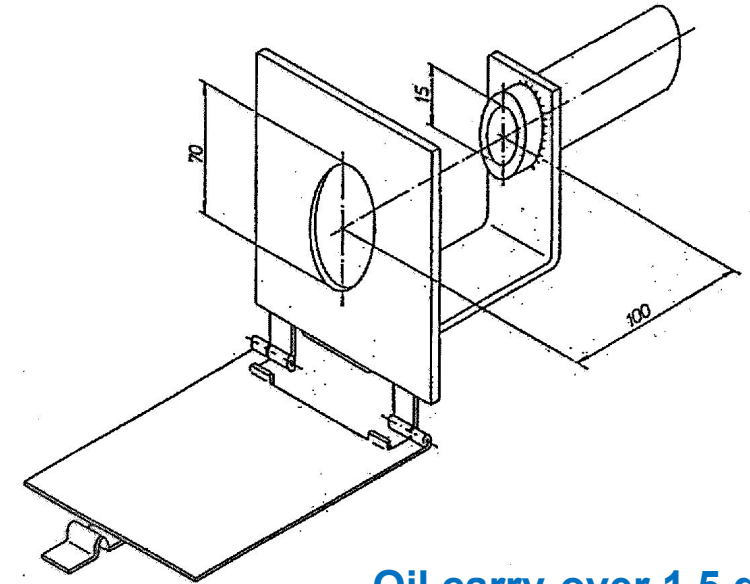

**Oil carry-over 1.5 g/h
at an engine revolution speed of
approx. 1,500 1/min**

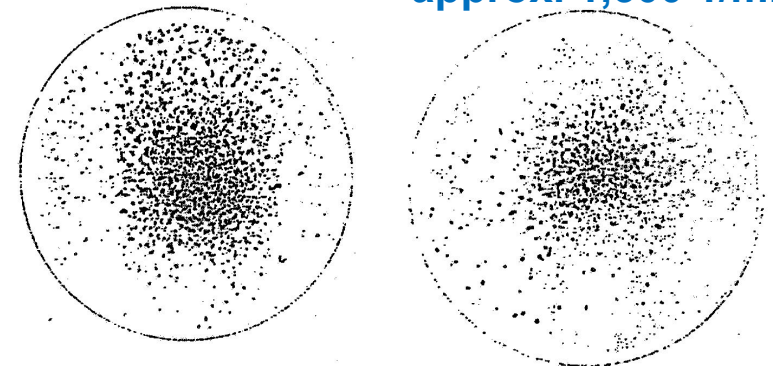

Maintenance need:

- In the case of replacing the V-belt, the V-belt must be retightened after 10 minutes of operation
- After a mileage of 10,000 km or 200 hours is reached, the pre-tensioning of the screws must be checked (cylinder head 26 Nm; cylinder 10 Nm; V-belt pulley 80 Nm)
- Increase of charging time – checking of plate valve

Air treatment system

Installation sample for switchable compressor

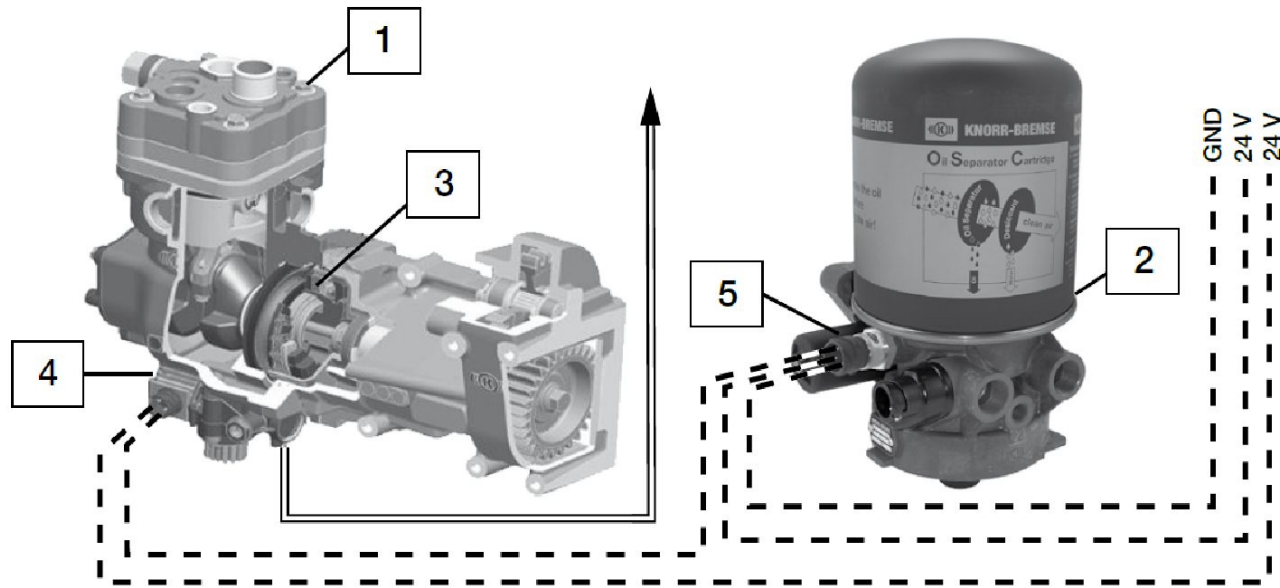

1. Switchable compressor
2. Air dryer
3. Switching device
4. Solenoid valve
5. Sensor

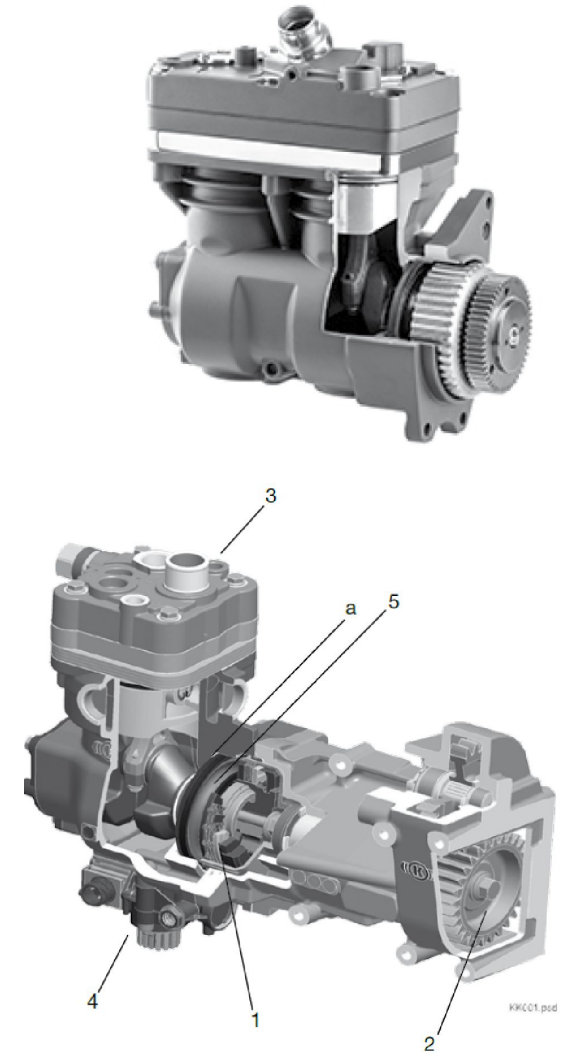

1. Switching device
2. Drive
3. Compressor
4. Solenoid valve
5. Piston

Benefits

Compressor Service Strategy

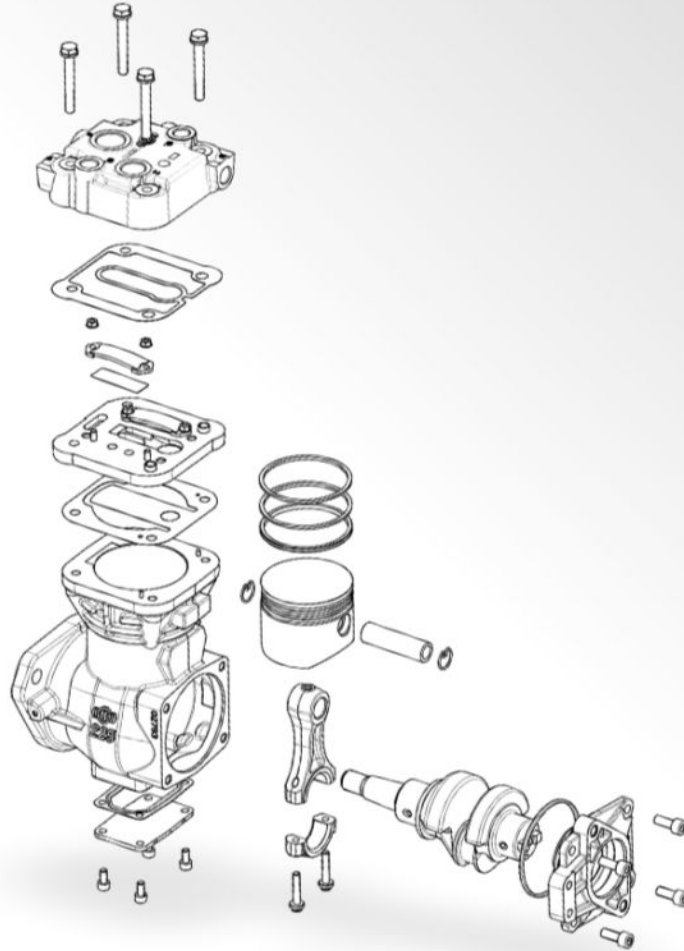

General Maintenance Kit



Cylinder Head Kit



Valve Plate Kit



Piston Kit



TRUCKSERVICES



Air treatment system

Compressors – Current service information



Air treatment system

Automatic alcohol injector (LA41..; 0 484 451 002 - 018):

Suggestions for application:

- Devices without a control connector (connector No. 4) have to be installed before the unloader valve .

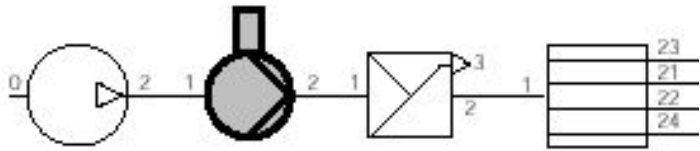

- Devices with a control connector have to be installed after the unloader valve .

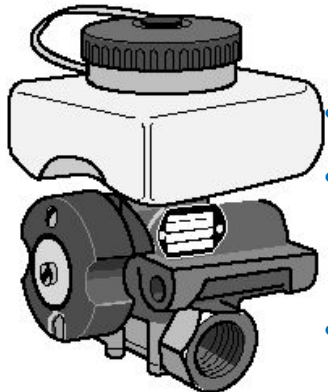
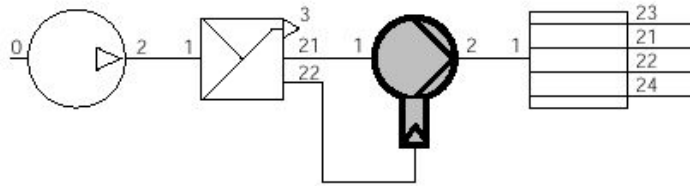

Suggestions for operation:

- Air reservoirs have to be drained regularly
- The reservoirs of the alcohol injector have to be filled up at all times (it has to contain the minimum level even in the summertime position)
- Suggested defrosting material: PAPAN SOFRO (out of KB portfolio)

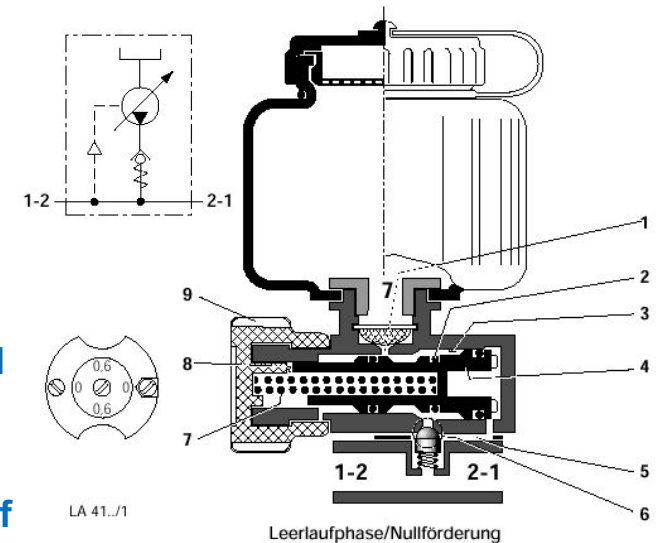
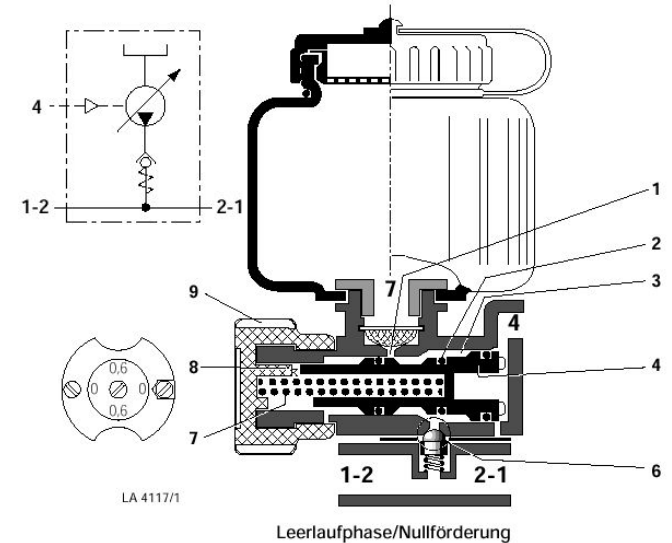

Air treatment system

Unloader valves (DR35..; AC135..; 0 481 039 ...; 0 481 042 ...)

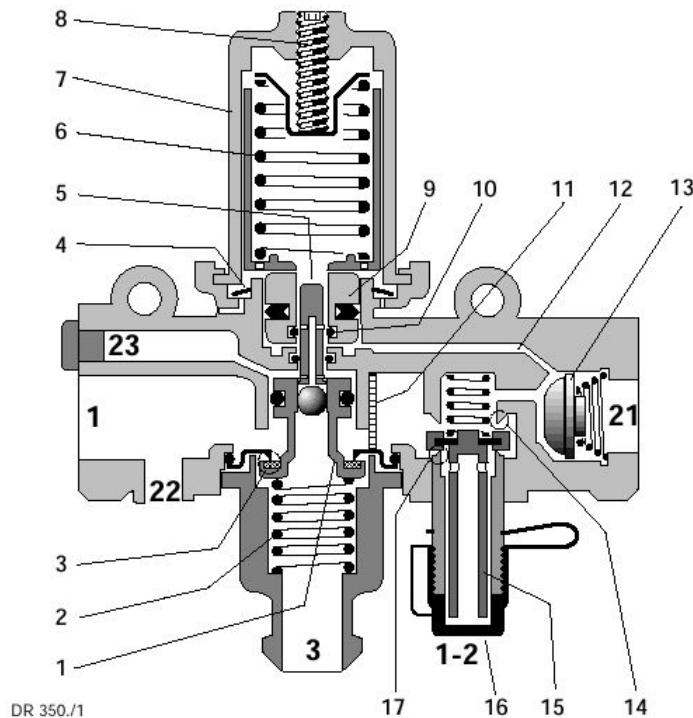

DR 350./1

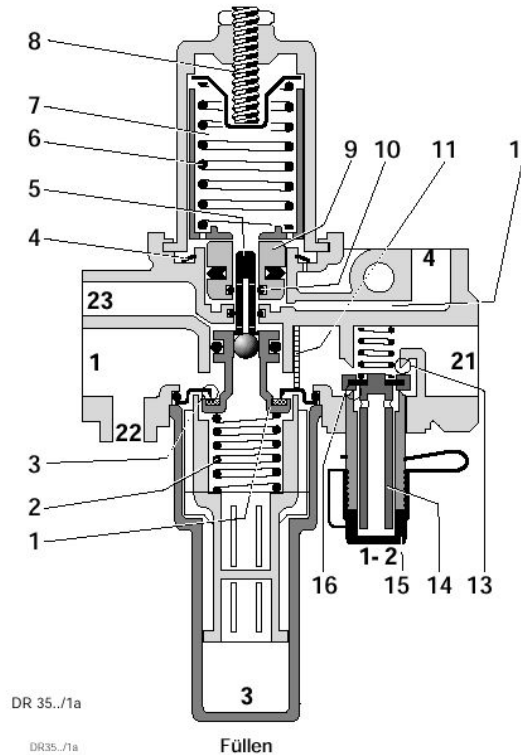

DR 35../1a

DR35../1a

Füllen

Functions:

- Delivery phase
- Exhaust phase
- Tyre inflation
- External charging
- Safety valve

Characteristics:

- Switch-off pressure (e.g.: 8.1 bar)
- Switch-on pressure (e.g.: 0.9*8.1 bar)
- Switching interval (0.8 bar)

Suggestions for installation:

- Preferably, the exhaust port should look downwards, in general the maximum offset can be 45 degrees.
- For the output connector the use of a pipe the size of 18x1.5 is recommended.

Suggestions for servicing:

- After a longer operation period, the switch-off pressure has to be checked, if there is difference, the switch-off pressure has to be adjusted by changing the pre-tensioning of the compression spring No. 6 through the screw No. 8.

Air treatment system

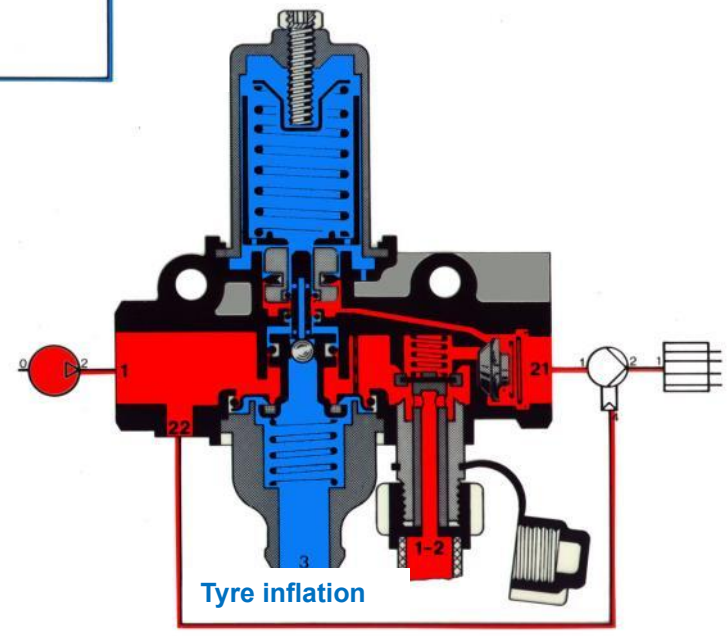
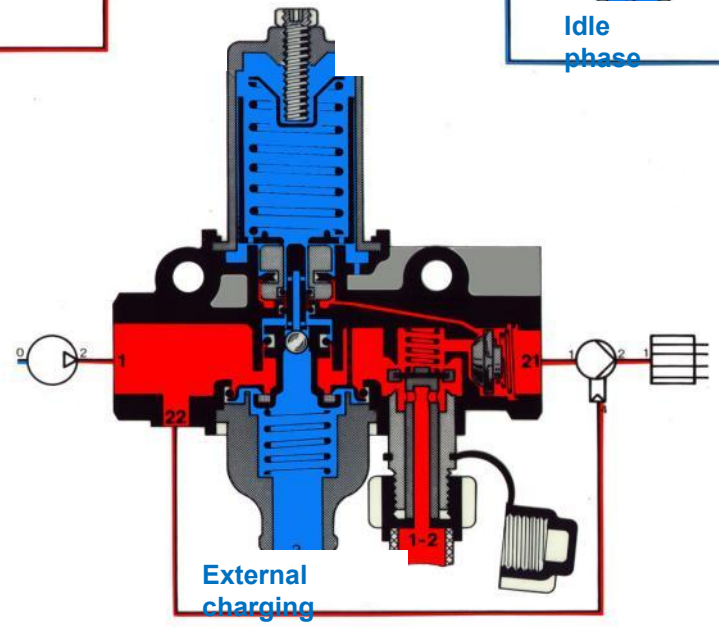
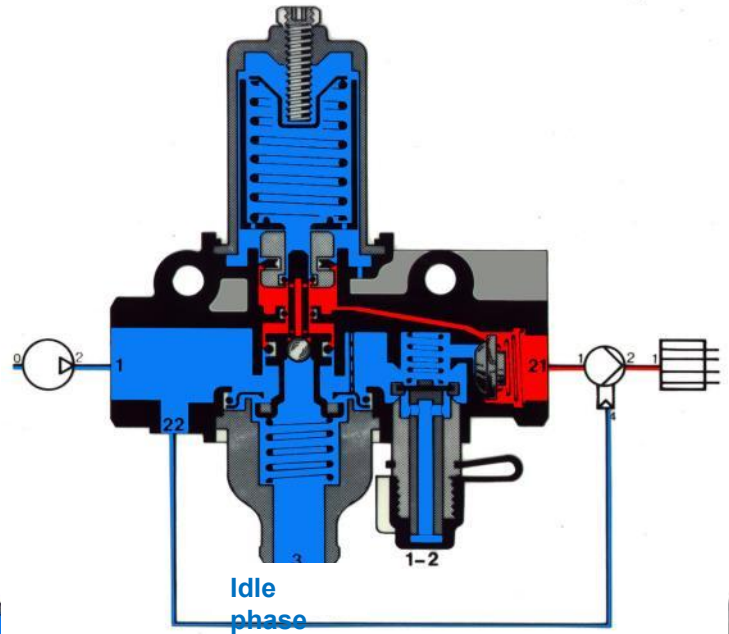
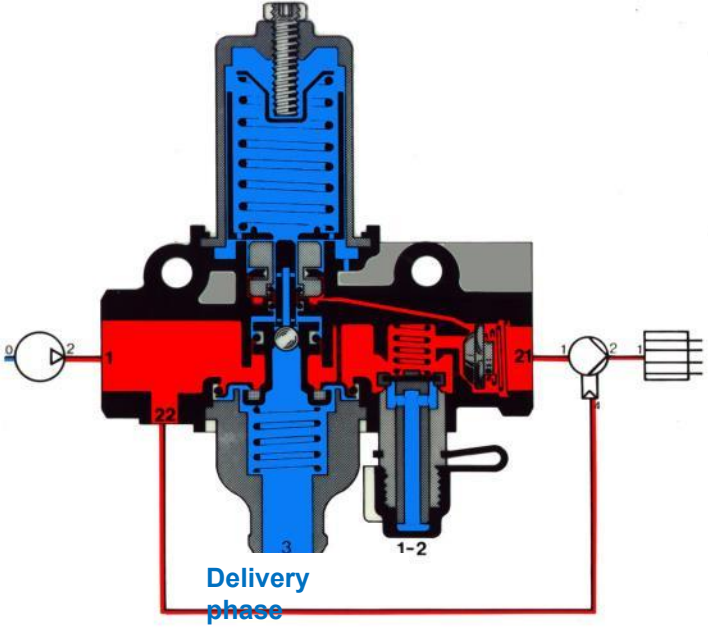

Air treatment system

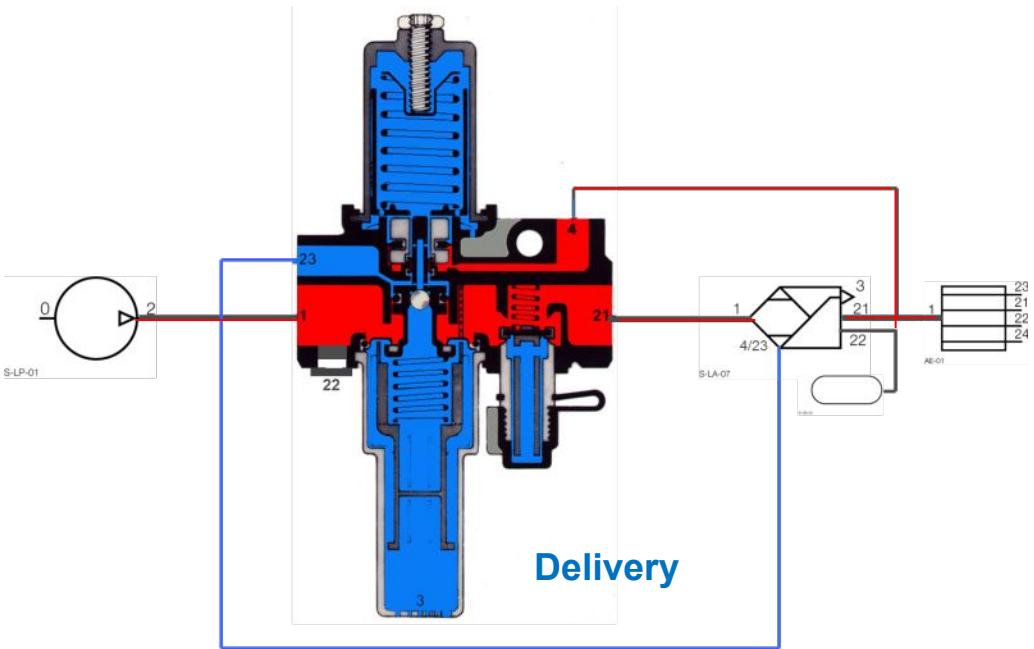

Using a unloader valve in the case of an air dryer without a unloader valve (LA67.. or LA87..)

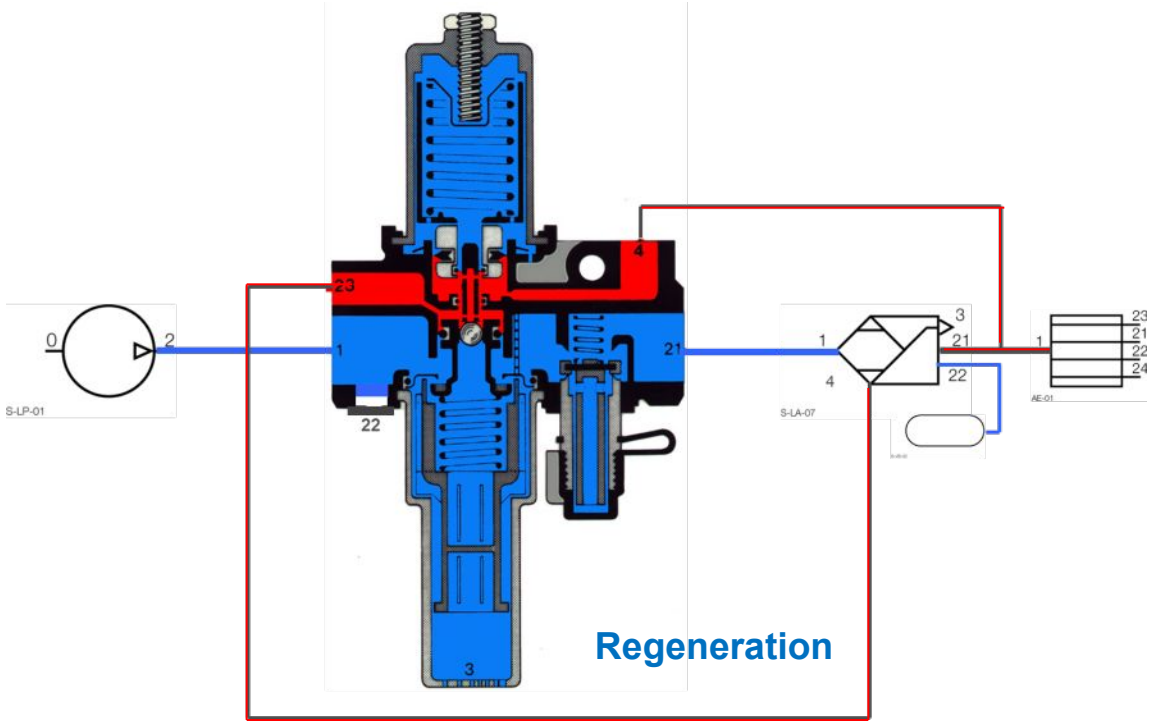

Governor:

A special version of unloader valves that is used mostly on vehicles manufactured in Scandinavia (Volvo, Scania).

In most cases it is used to control the compressors that have an ESS function and less often for controlling air dryers.

Characteristics:

- Switch-off pressure, switch-on pressure, switching interval
- e.g. 295 201 (Volvo F12, F16)

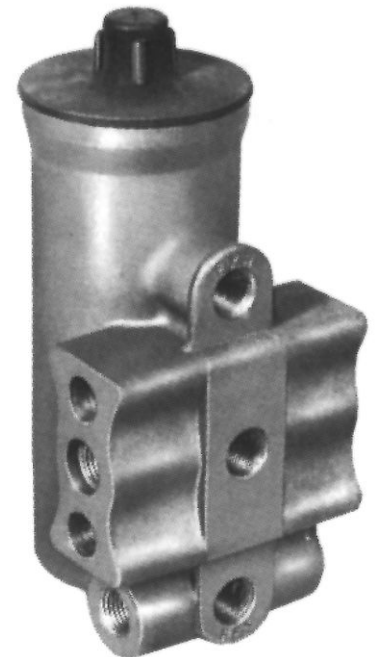
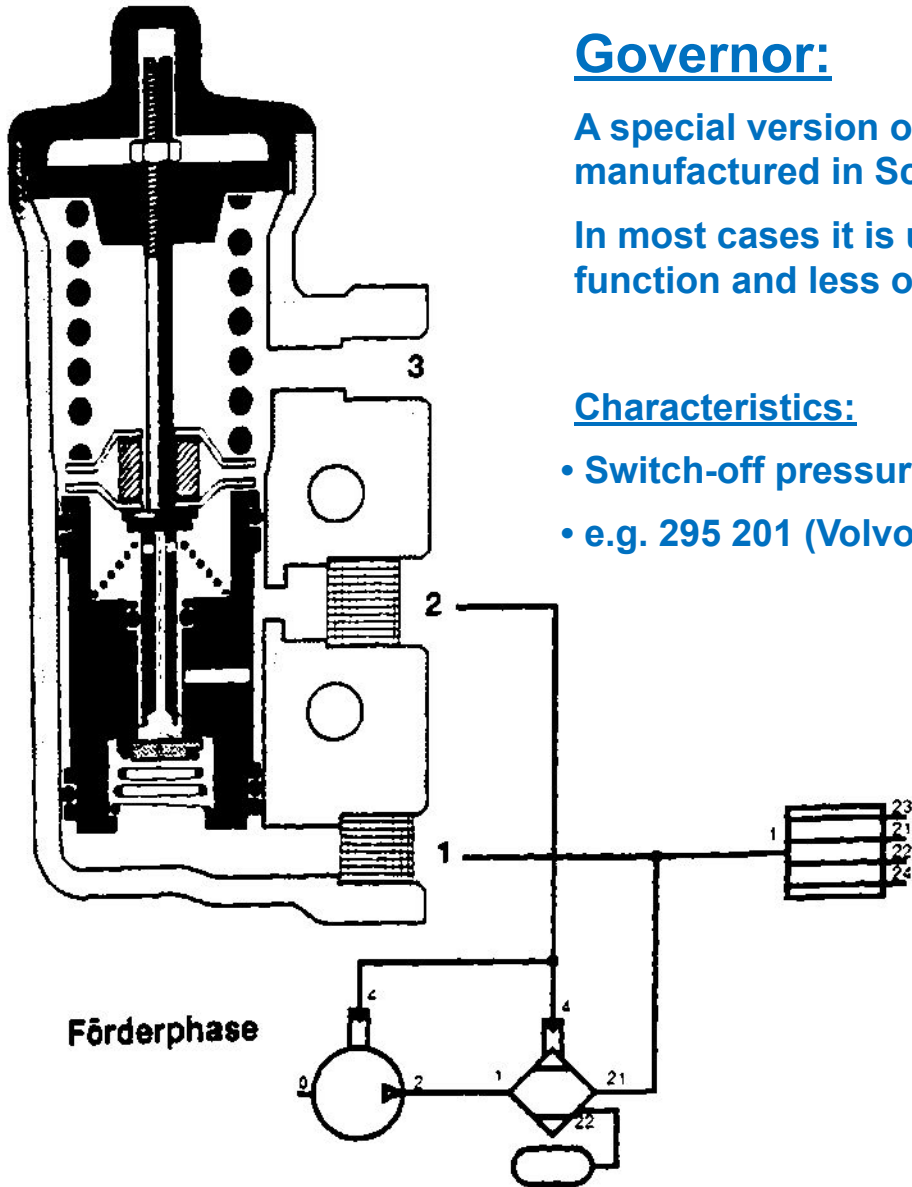

Air treatment system

Air dryer (LA60..; LA62..; LA67..; LA80..; LA82..; LA9...):

Advantages:

- Reduced extent of corrosion due to condensate
- Inappropriate defrosting materials and condensate do not reduce the lubricant film layer in further fittings.
- Pressure regulation is performed where the air is already cleaned, thus the risk of failure is lower.

Suggestions for installation:

- In the case of models with a regeneration reservoir, the charging time may be 3-7% longer.
- It must be ensured that the switch-on time of the compressor does not increase above 50-55%. (Above 60% the use of an air dryer is not recommended.)
- Do not use an alcohol injector together with it.

The selection of the regeneration reservoir depends on:

- Total volume of container
- Switching interval of the unloader valve
- Switch-off pressure level
- Switch-on duration of the compressor

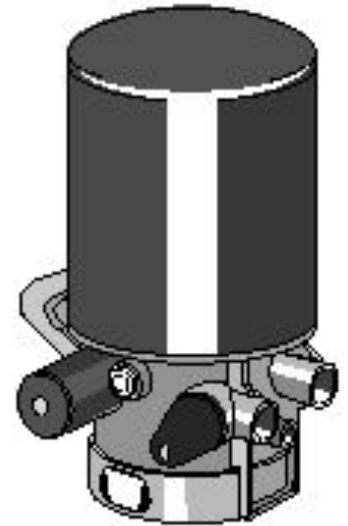

Förderphase

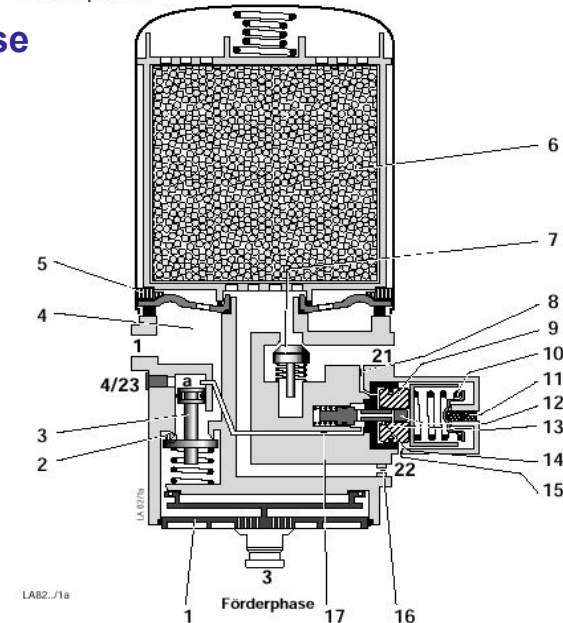

Air treatment system

② \ ①	7,35	8,1	10,0	12,5
80				
100			③	
120			④	
160	⑤			
200	⑥	⑤		

Choosing the reservoir size:

- 1 Switch-off pressure
- 2 Total volume of container
- 3 The size of the regeneration reservoir is 4 L
- 4 The size of the regeneration reservoir is 5 L
- 5 The size of the regeneration reservoir is 7 L
- 6 The size of the regeneration reservoir is 9 L

Ensure that the maximum temperature of the air entering the air dryer is 65°C and that a damper tank of 1-1.5 L is used before the air dryer.

Recommended size of connecting pipes: 18x1.5; its length between the compressor and the air dryer has to be between 4 and 6 meters.

It must be ensured upon installation that during the regeneration phase the remaining pressure at the inlet connector is less than 0.25 bar.

Types and operation of air dryers:

Types:

- With time switch (LA60.. and LA80..) or with regeneration reservoir (LA62.. and LA82..)
- With integrated unloader valve (LA6... and LA8...) or without unloader valve (LA67..)
- Models that can be integrated with protection valves of four or more circuits (LA9...; LA81..).

Air treatment system

Development of air treatment systems

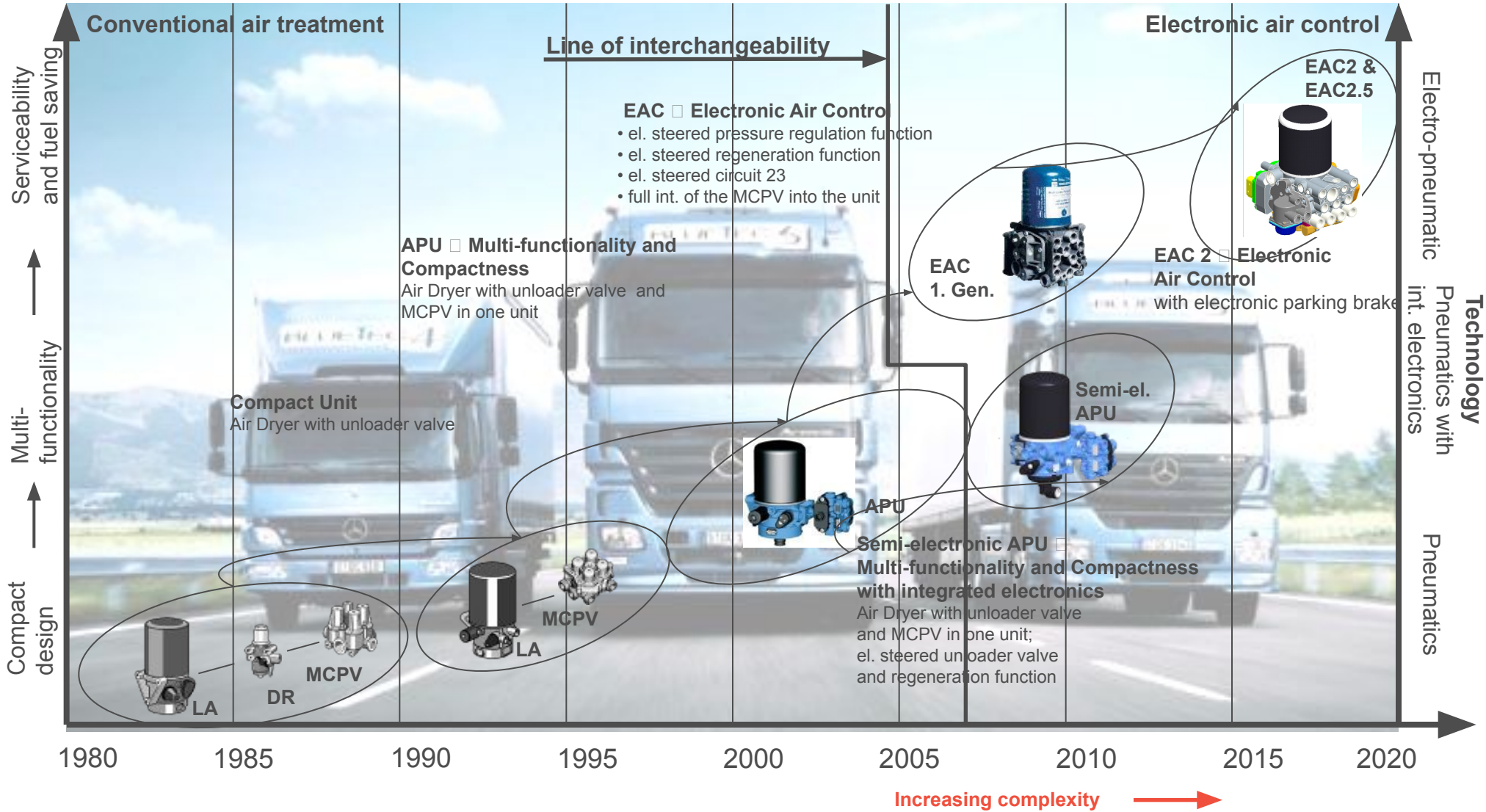

Air treatment system

Overview of air dryers



LA82 /
LA80

Independent air dryer
with integrated
unloader valve and
heater (with optional
“time switch”)

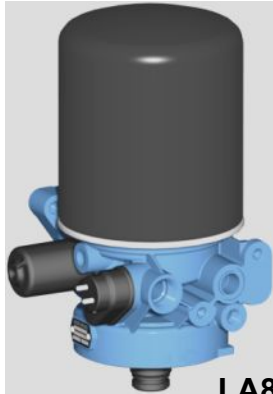

LA87

Independent air dryer
without integrated
unloader valve / heater



LA86

Model that can be
installed in an air
treatment unit with
integrated unloader
valve /
“time switch” / heater /
level control output



LA90

Model that can be installed in
an air treatment unit with
integrated unloader valve /
tyre inflation / heater / level
control output and external
charging



LA81

Model that can be installed in
an air treatment unit with
integrated unloader valve /
relay function / tyre inflation /
heater / level control output
and external charging

Air treatment system

LA67.. or LA87.. Structure of the air dryer

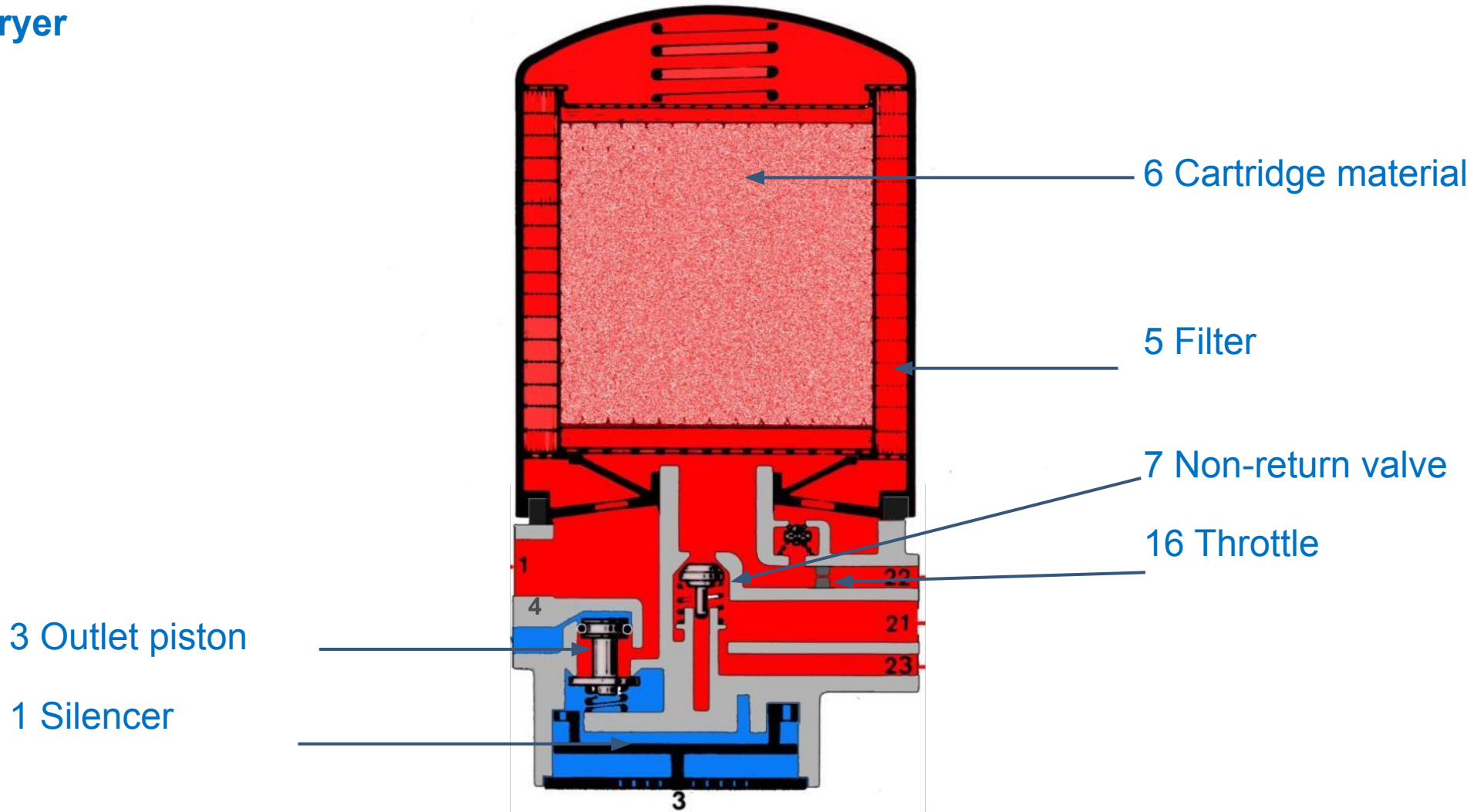

Air treatment system

Operation of air dryer LA67.. or LA87..

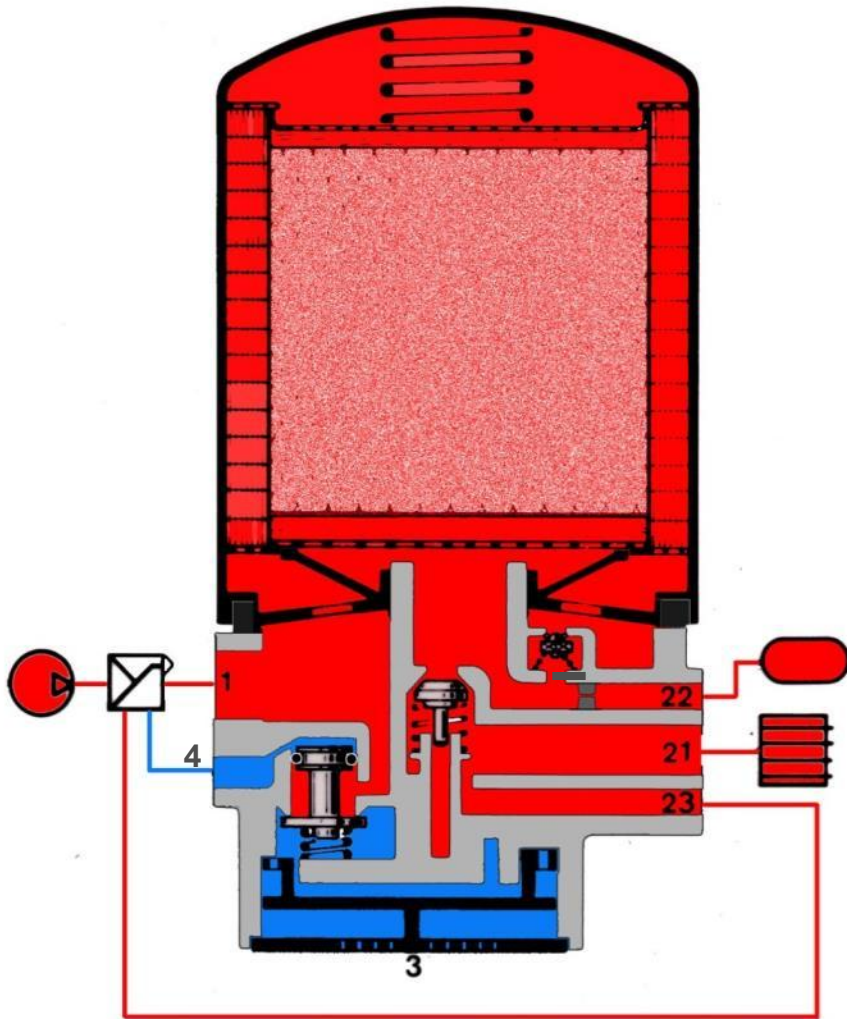

Delivery
phase

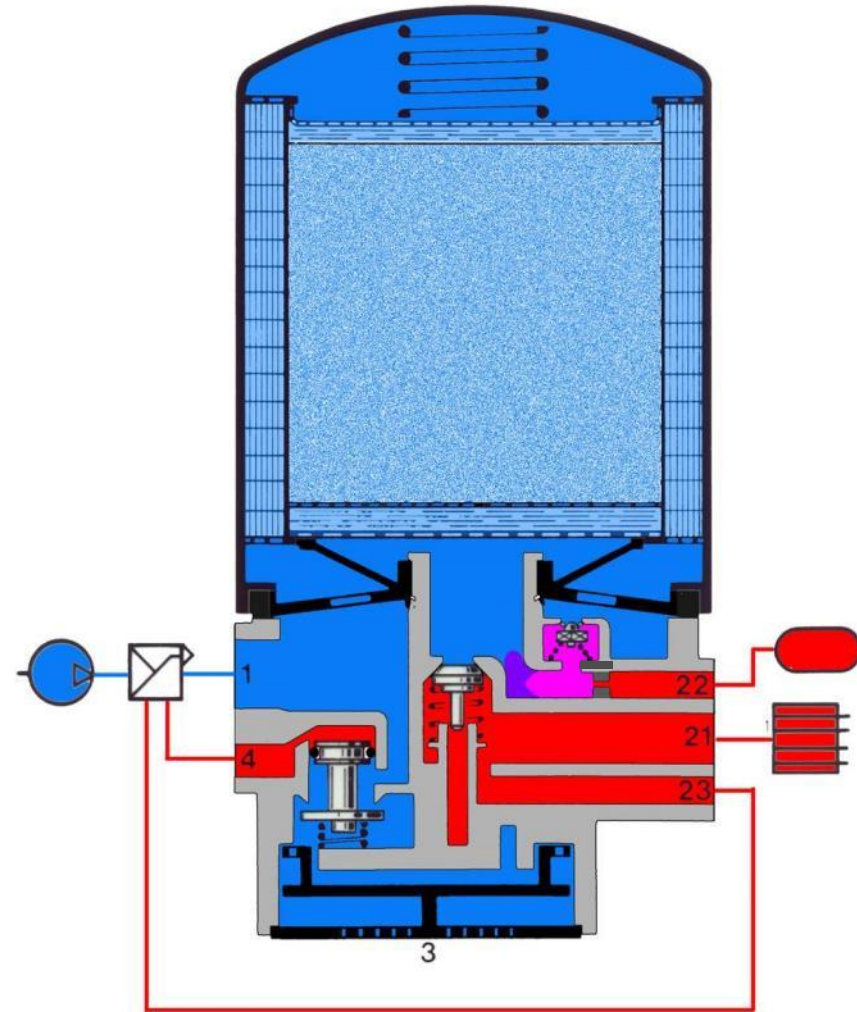

Regeneratio
n

Air treatment system

Structure of air dryer LA82..

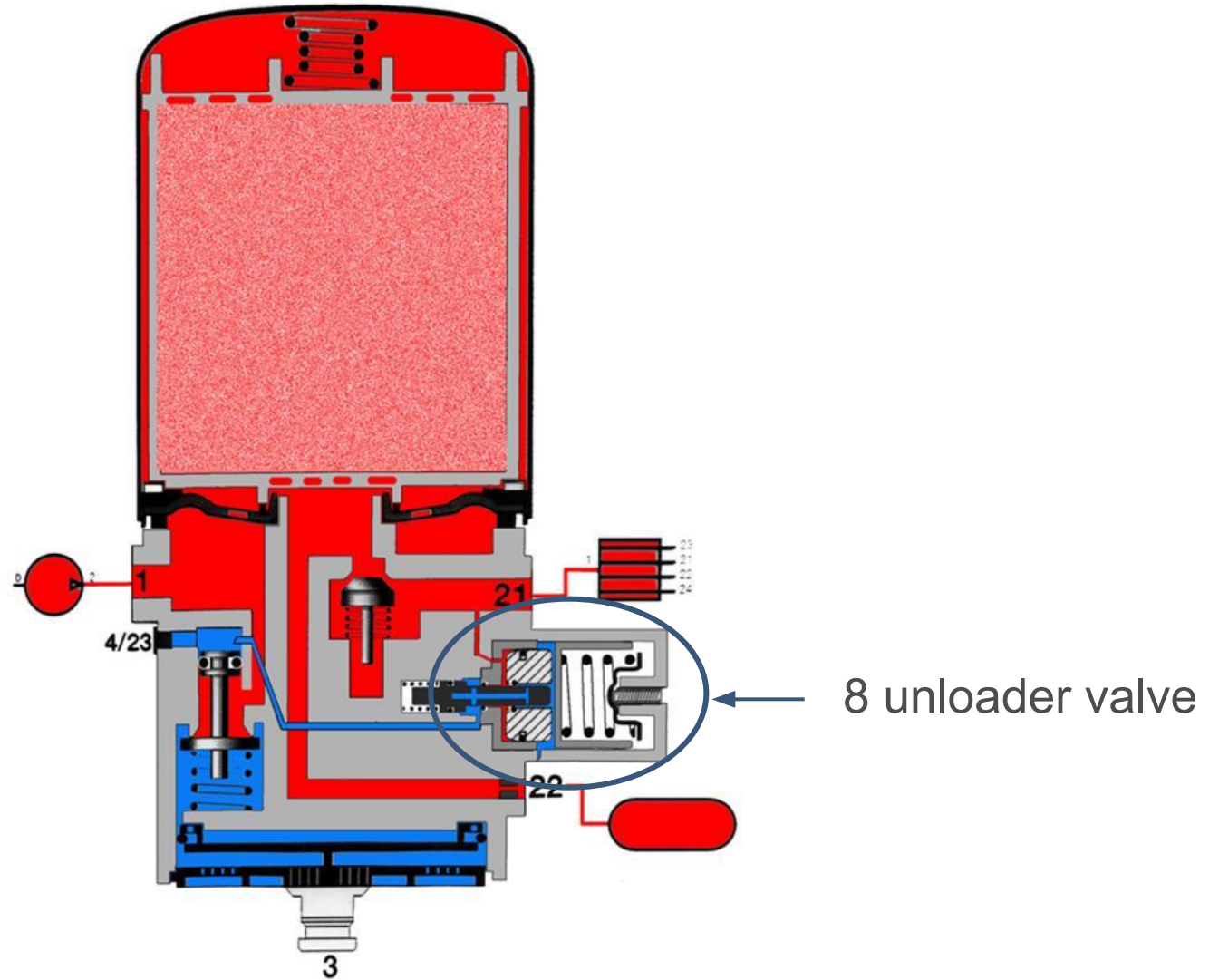

Air treatment system

Operation of air dryer LA82..

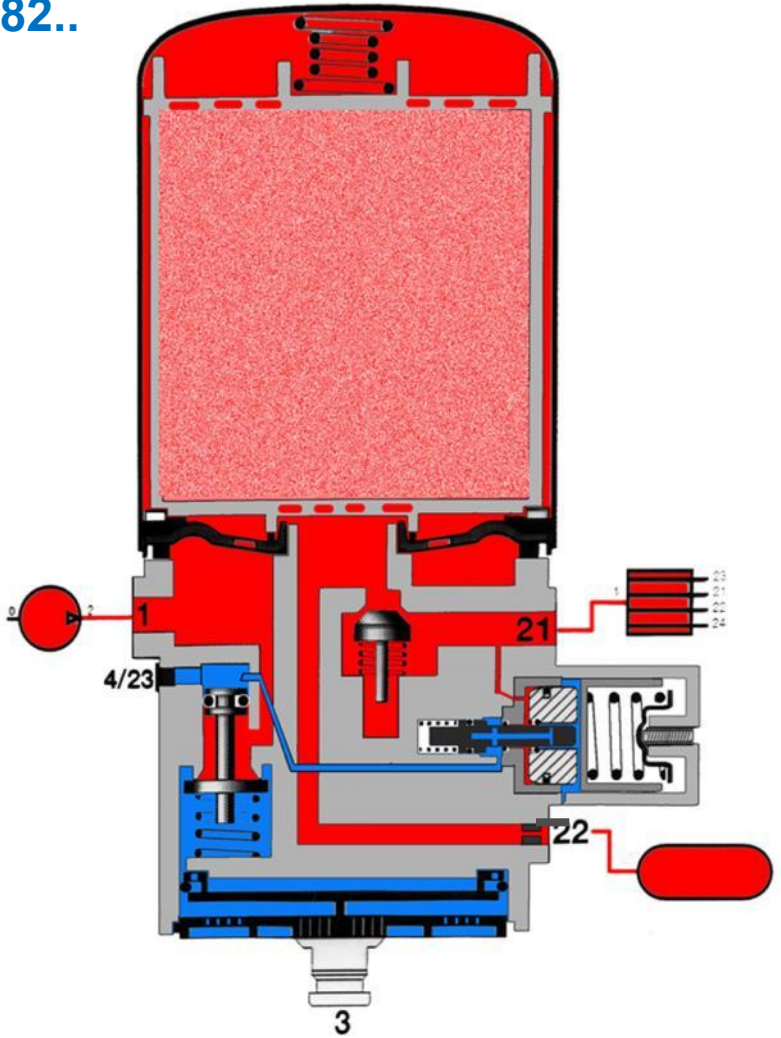

Delivery phase

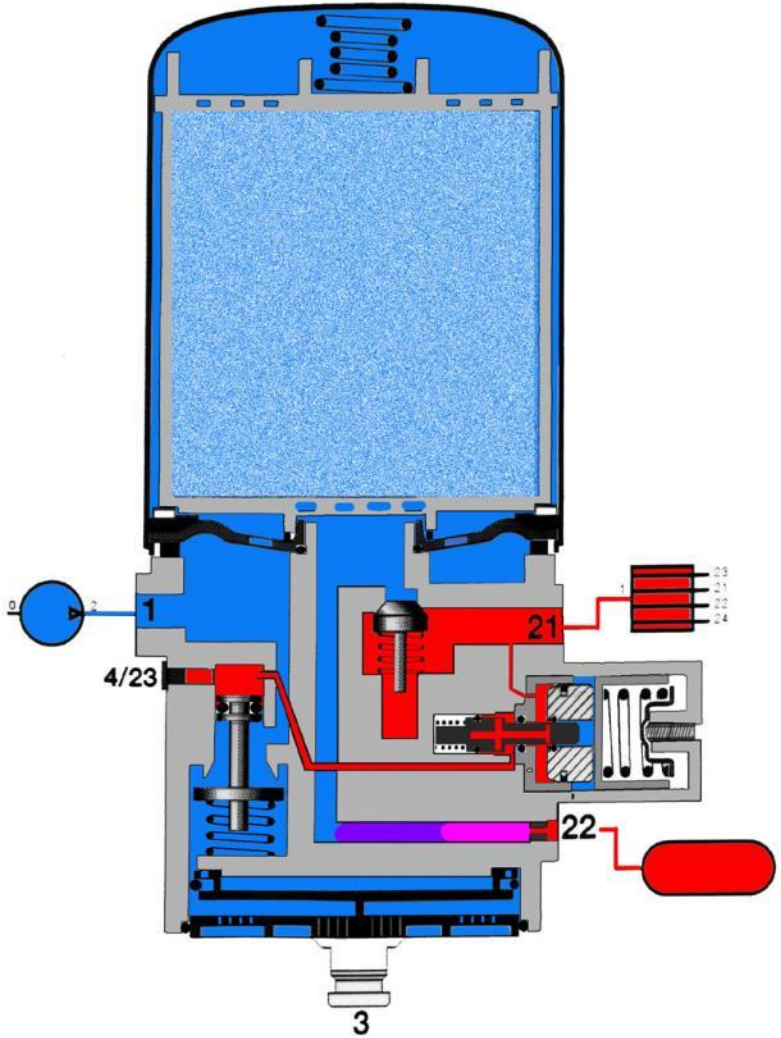

Regeneration

Air treatment system

Structure of air dryer LA80..

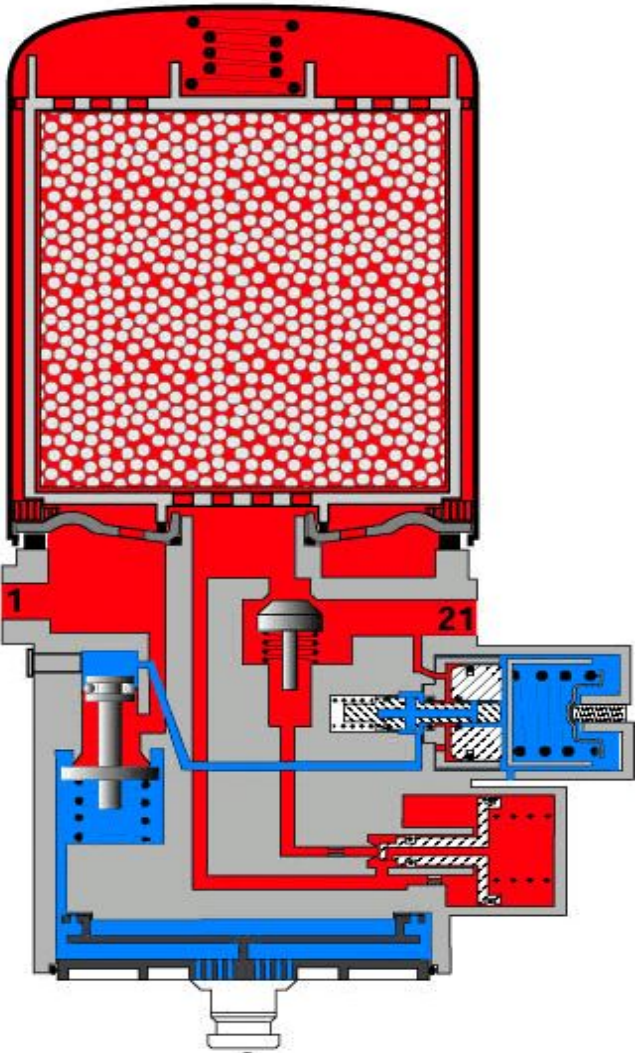

Delivery phase

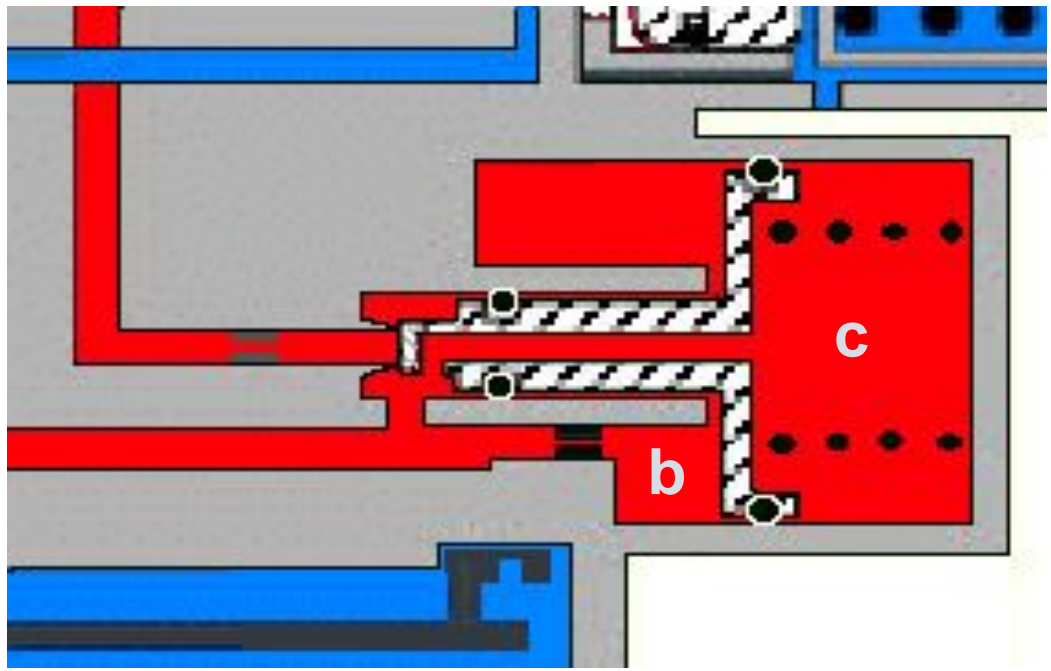

Air treatment system

Structure of air dryer LA80..

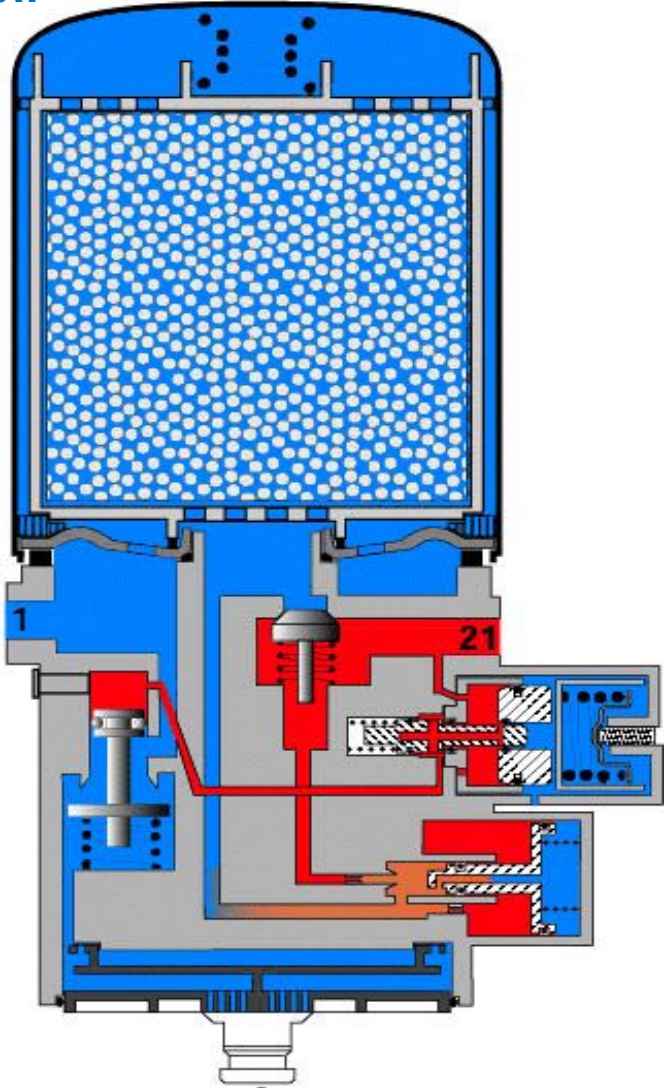

Regeneratio n

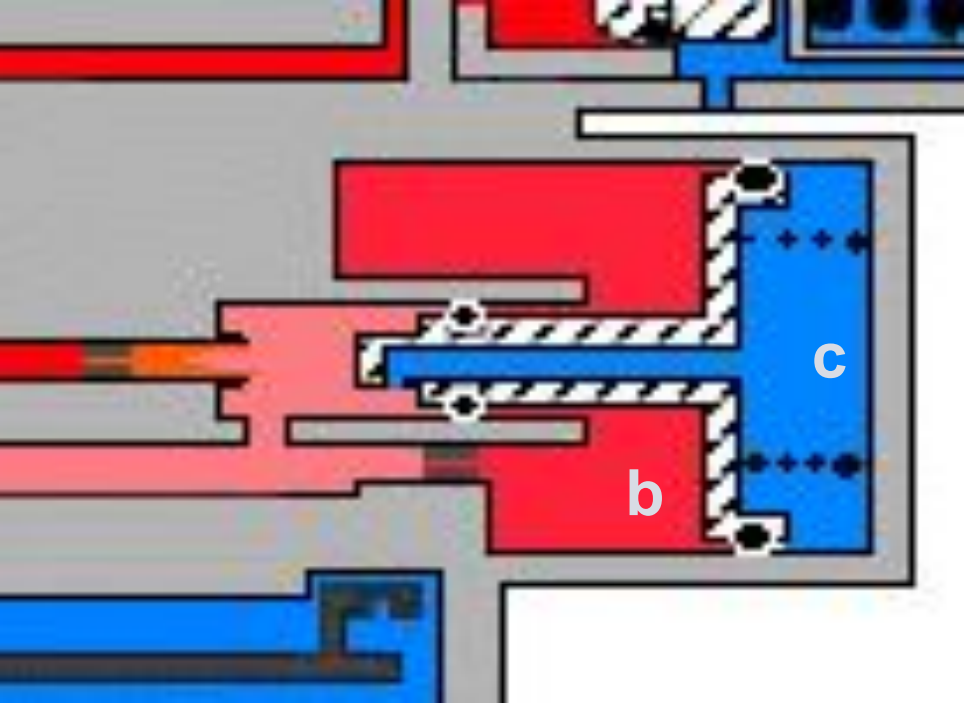

Air treatment system

Air dryer LA9... and LA81.. for the complex air processing units APU (ZB45..; ZB47..)

LA9...

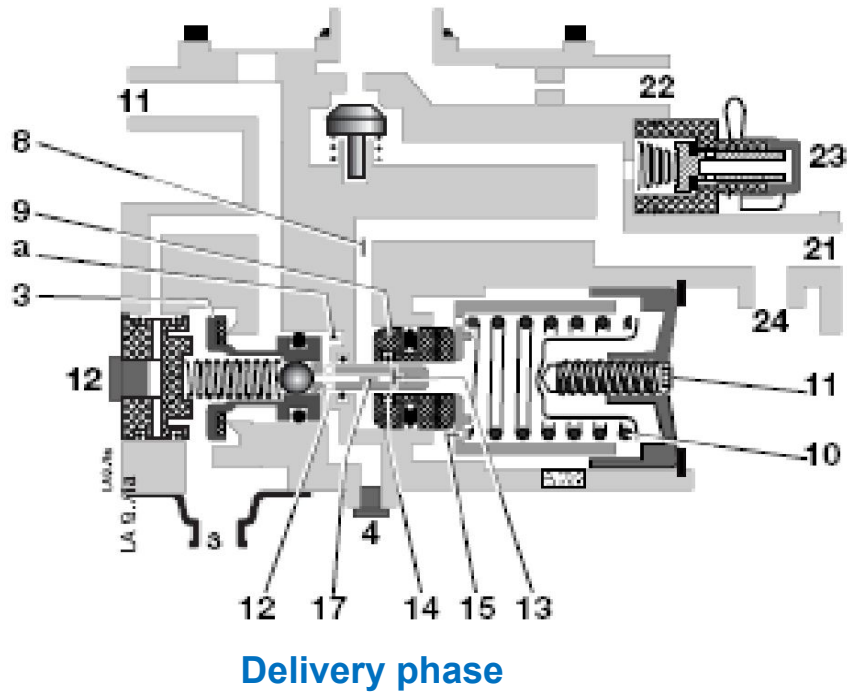

LA81..

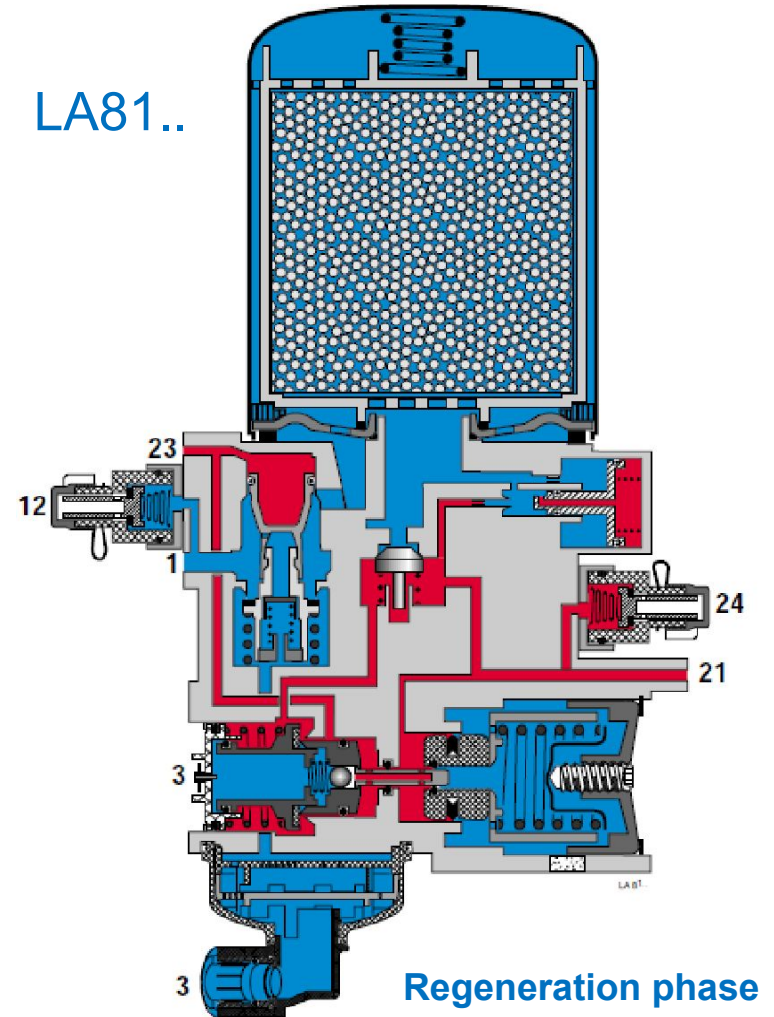

Air treatment system

Semi-electronic air dryer (EL9...)

- Intelligent pressure regulation and regeneration control by the central electronics of the vehicle,
- It performs the commands of the vehicle electronics with the help of two electromagnets,
- It is a model that can be installed in a complex air processing unit (ZE45../ ZE46..).

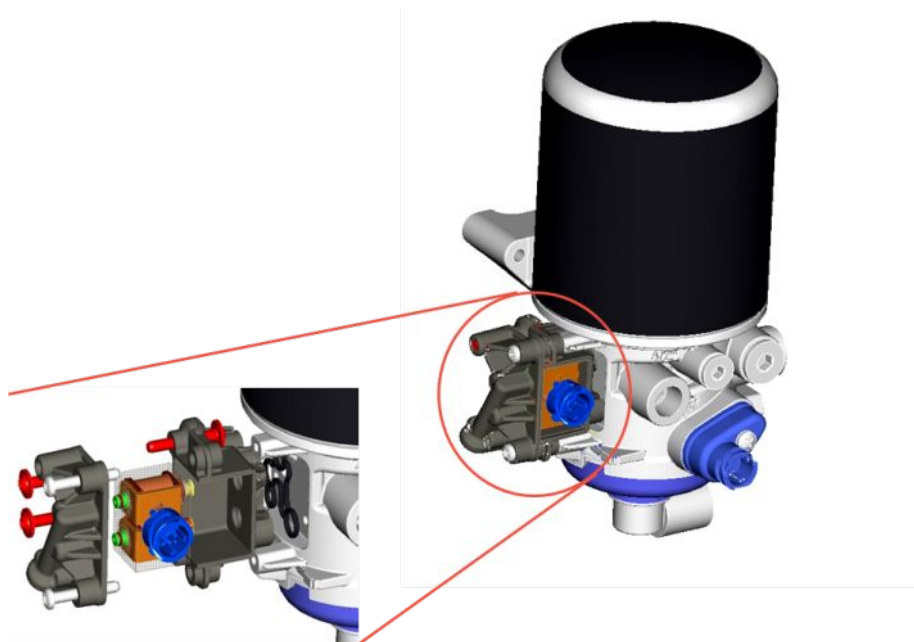

Cartridges and heaters

- Cartridges can have left or right thread,
- Cartridges can have different sizes,
- They can have a traditional or an oil separation structure.



Heater connectors can have different electric connectors. They have a performance of 100 W, switching on below 5°C and switching off above 27°C.



Air treatment system

Auxiliary equipment:

Silencers

Threaded design

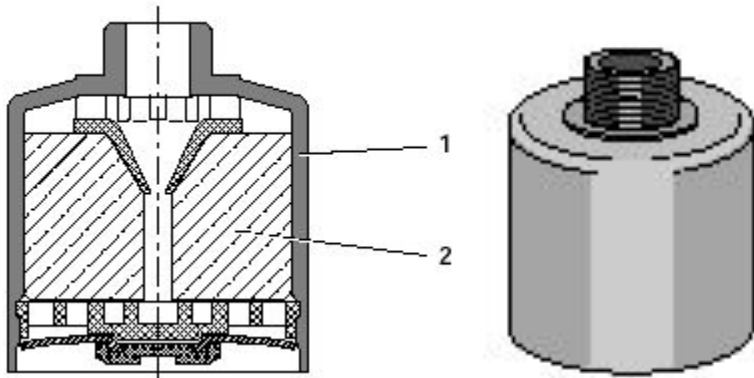

Snap catch design

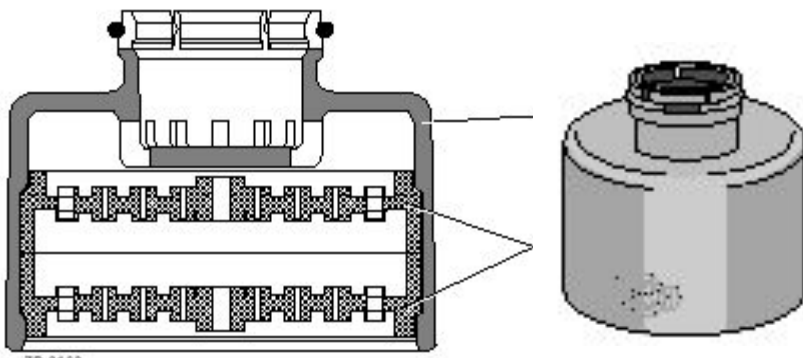

Drain valve

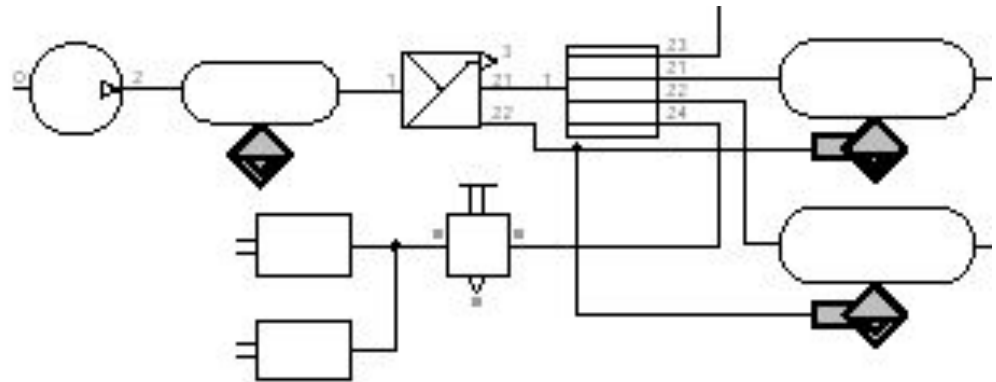
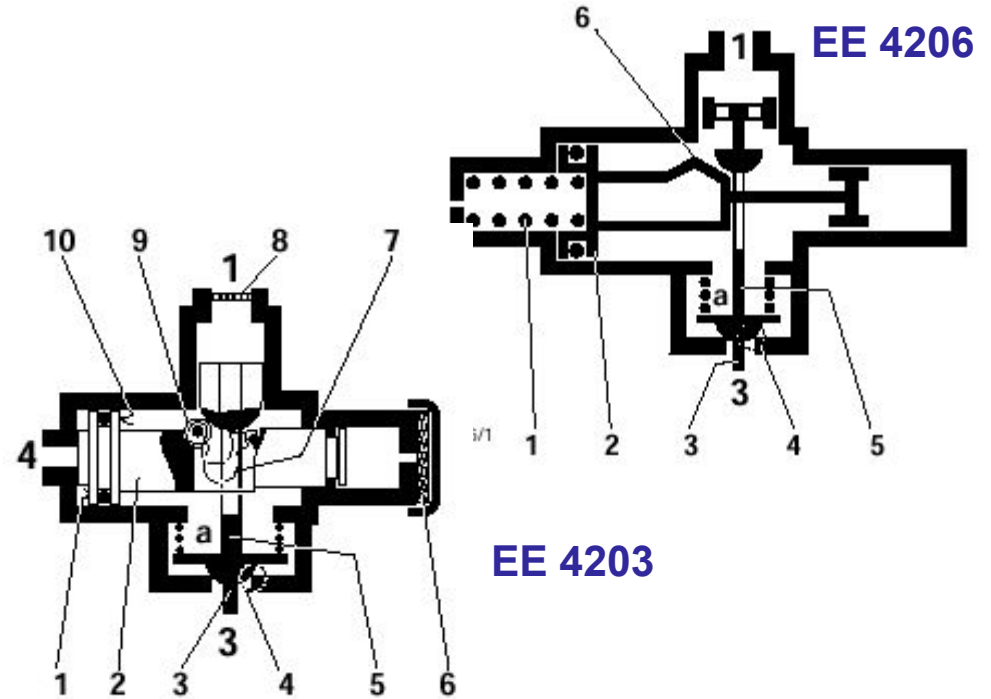

Air treatment system

Service Strategy

Complete Product



AM LA (1)
with cartridge

Cartridge



Cartridge (2)

OE Product



Silencer (3)

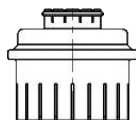

Heater (4)



Repair Sets

Service Kit
time switch
(5)

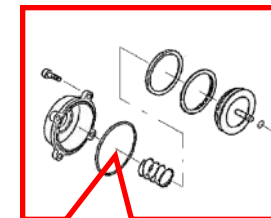

Service Kit
complete
(6)

Service Manual / Film and Documentation

For a quick replacement and service of subassemblies and components in accordance with high safety requirements.

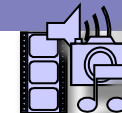

Air treatment system

Service Strategy

Complete Product



IAM LA (1)
Rationalised
with sealings



2a

IAM MCPV (2)
with sealings



2b

Cartridge and Sensor



Cartridge (4)

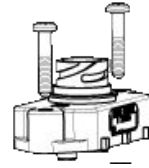

Double
Pressure
Sensor (5)

OE Product

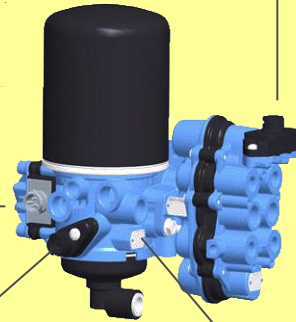

Heater (7)

Silencer (6)

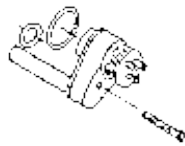

Repair Sets

Tyre Inflator Valve (8)



Solenoid Unit (9)

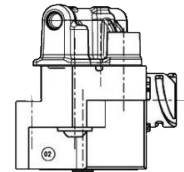

Service Manual / Film and Documentation

For a quick replacement and service of subassemblies and components in accordance with high safety requirements.

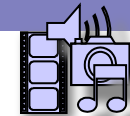

Air treatment system

Air dryer units – Current service information



Air treatment system

Charging valves:

Characteristics:

- Opening pressure, closing or secured pressure
- When installing, care must be taken to install the valve in the correct flow direction.
- The opening pressure has to be checked and if there is a difference, it has to be adjusted with the pre-tensioning screw.



With backflow

DR41..

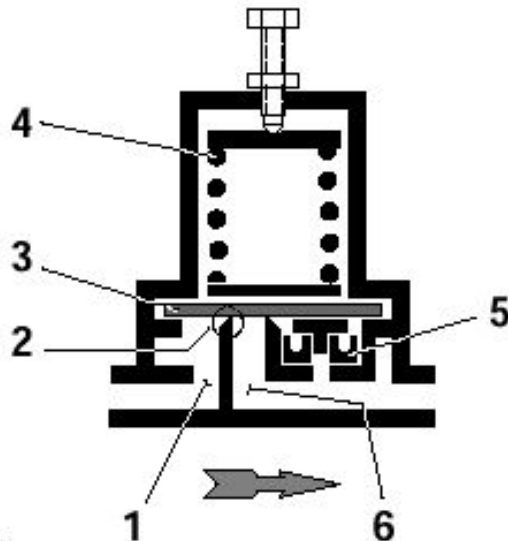

DR 41../1

With limited backflow

DR42..

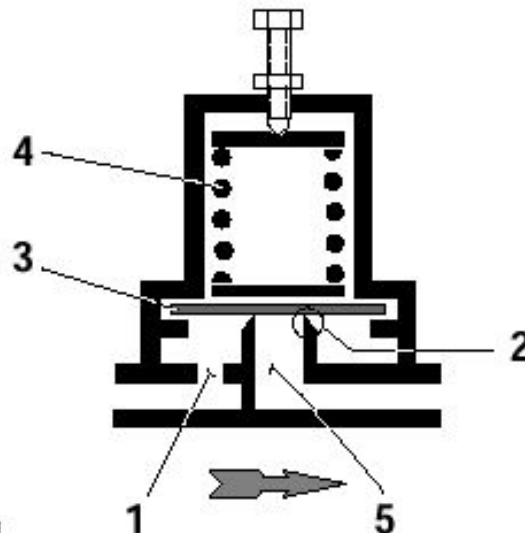

DR 42../1

Without backflow

DR43..

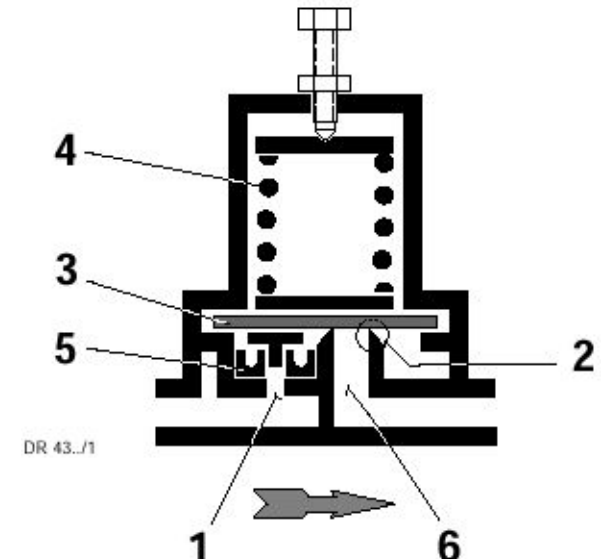

DR 43../1

Air treatment system

Charging valve with limited backflow (DR42..)

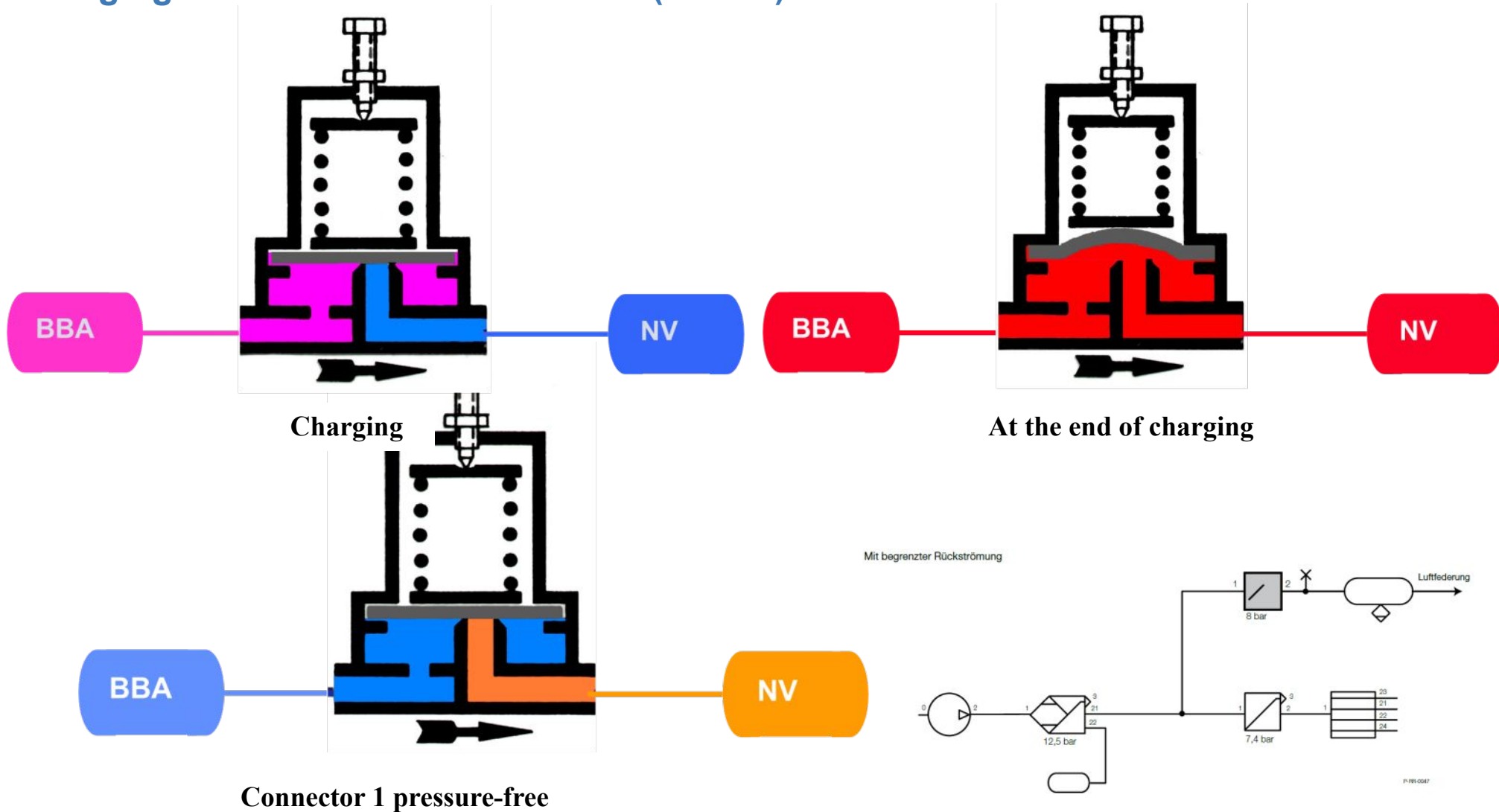

Air treatment system

Charging valve without backflow (DR43..)

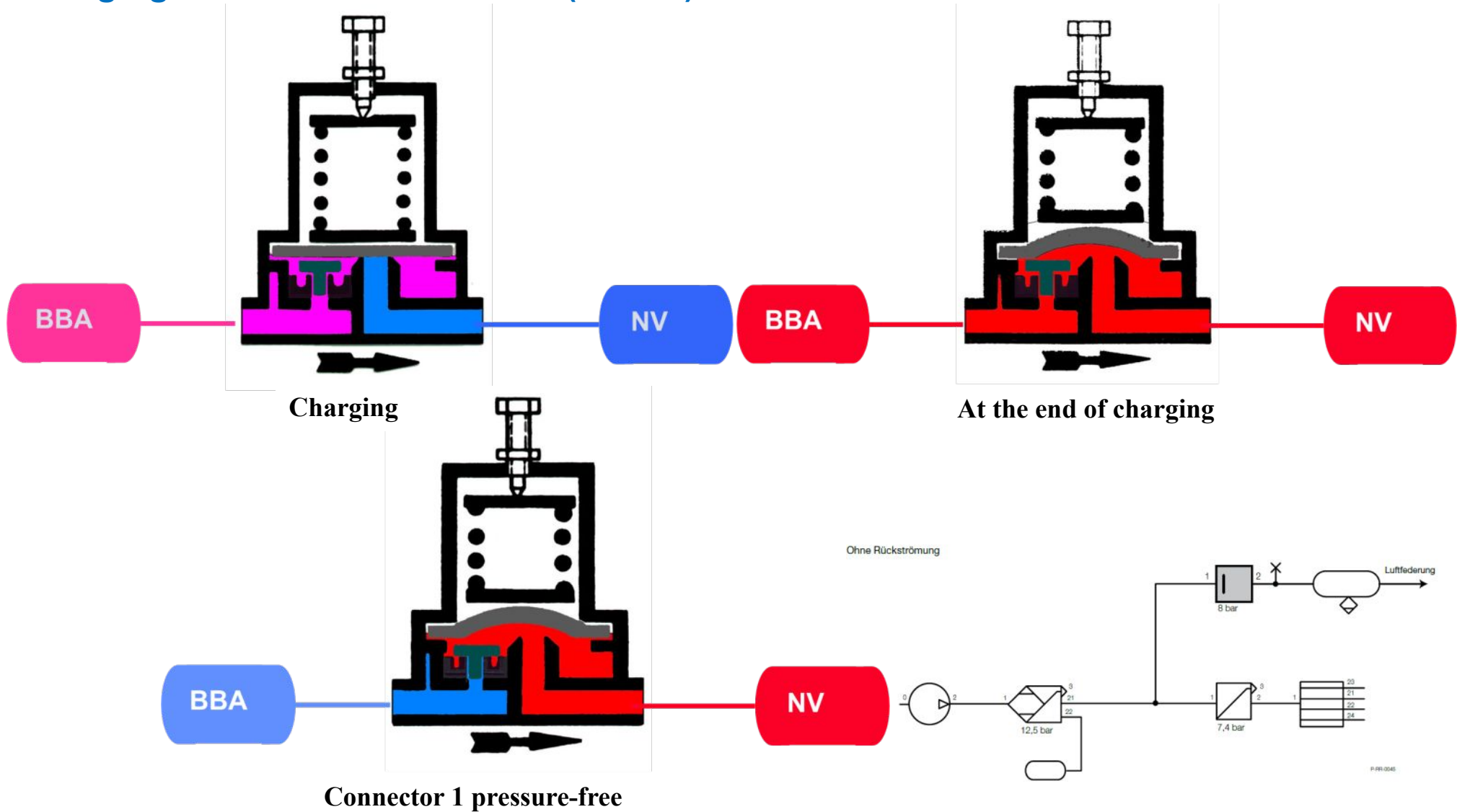

Air treatment system

Charging valve with backflow (DR41..)

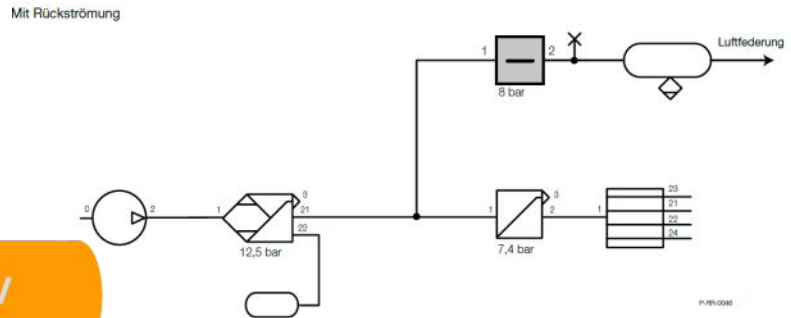
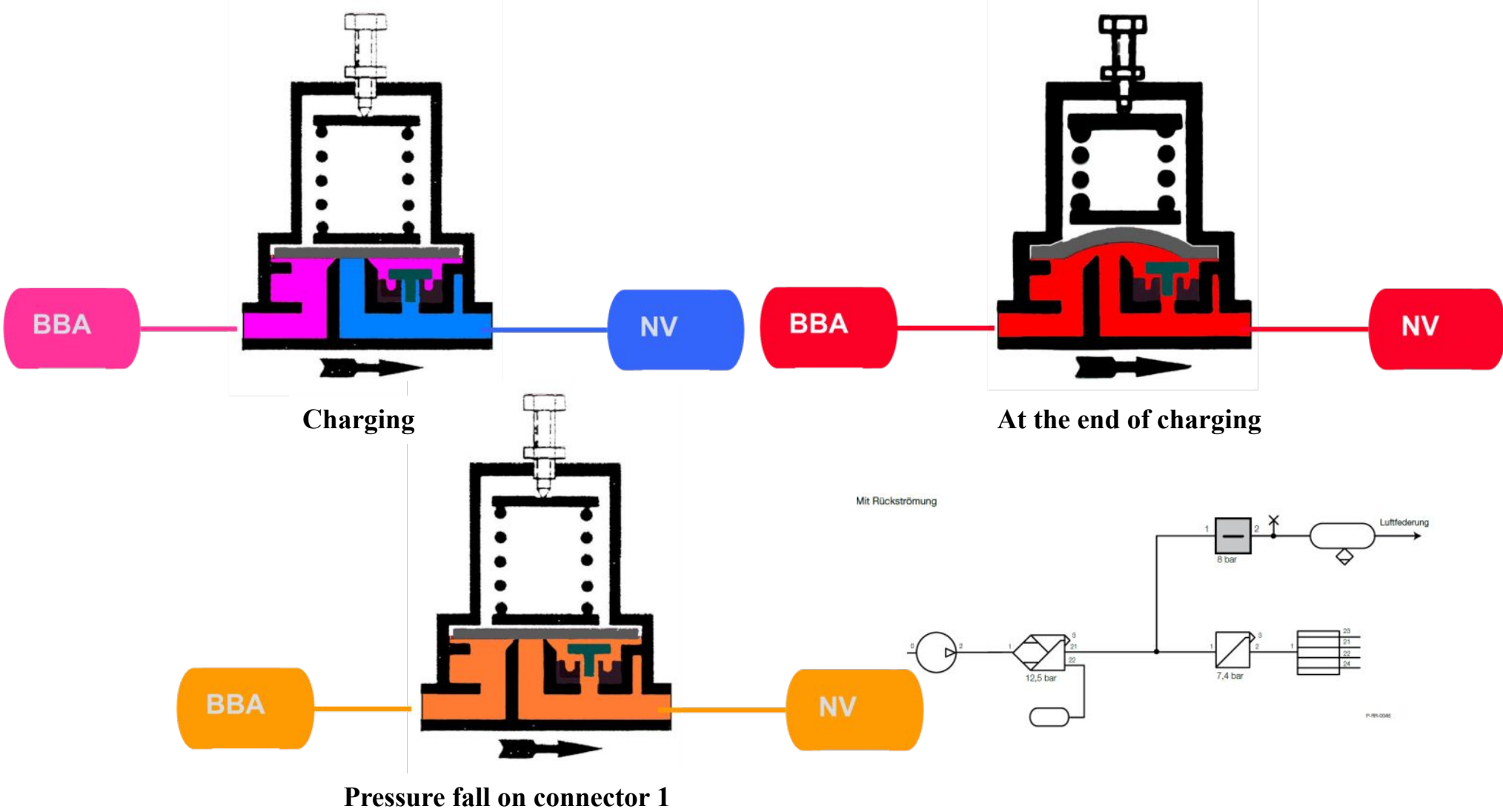

Air treatment system

Pressure limiting valve: AC15.. and DB11..

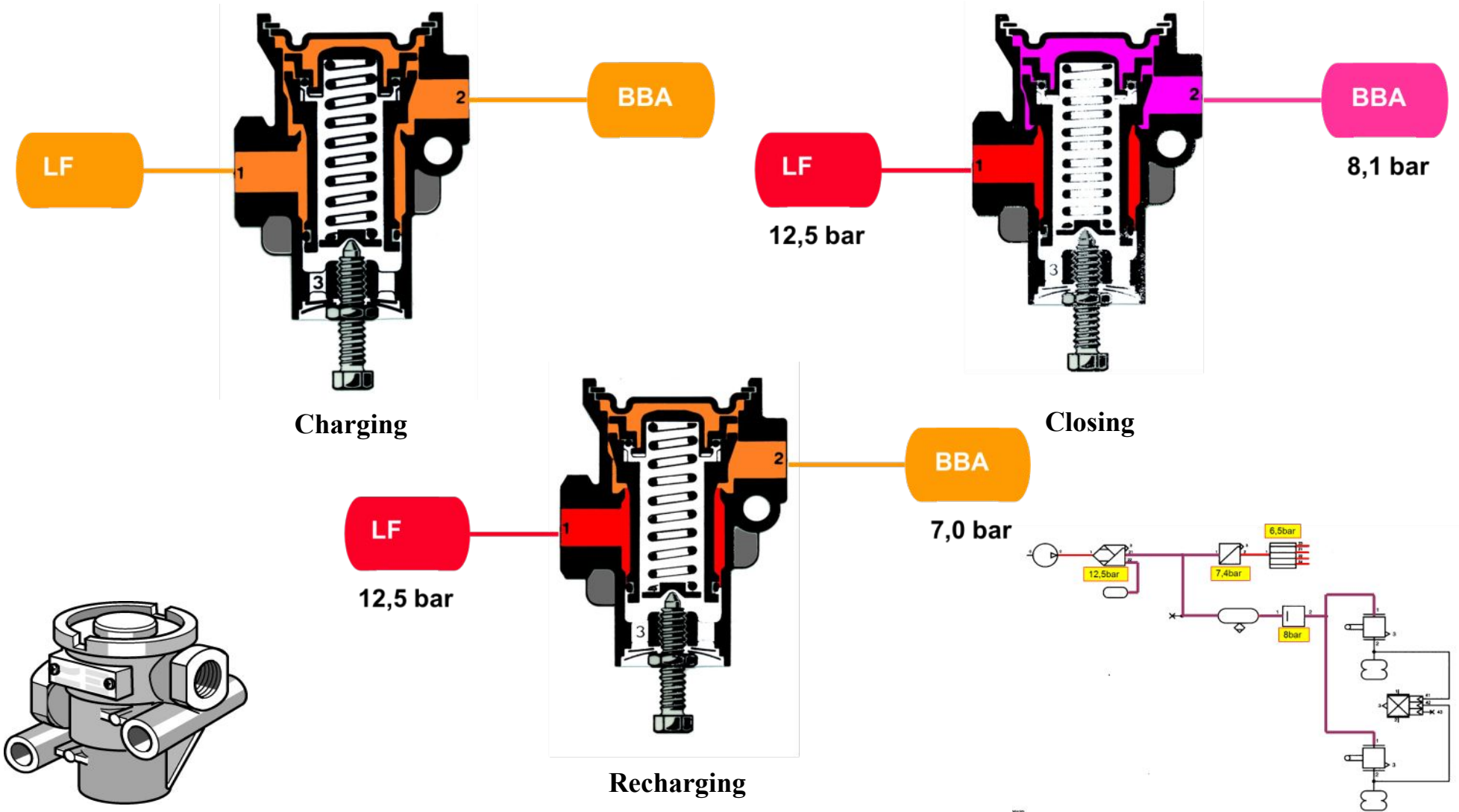

The four-circuit protection valve (AE41...; AE44...; AE45...; AE46...; AE48...):

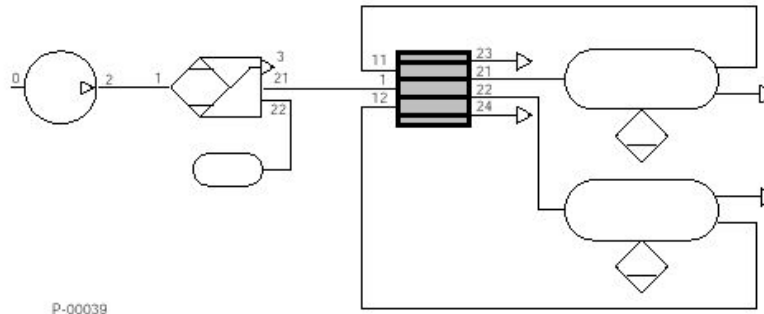

Its function:

Ensuring the so-called priority order during the charging of the air system.

If a circuit is damaged, ensuring the separation of the damaged circuit from the undamaged circuits.

Characteristics:

- Opening pressures of the circuits (order of opening)
- Static closing pressure (dynamic closing pressure): The pressure level at which the damaged circuit closes (the diaphragm valves close), if the compressor is not delivering.
- The secured pressure: The pressure level that is present in the undamaged circuits when the compressor is delivering continuously, which is the same as the opening pressure of the damaged circuit.

Air treatment system

Types of the four-circuit protection valves:

Line

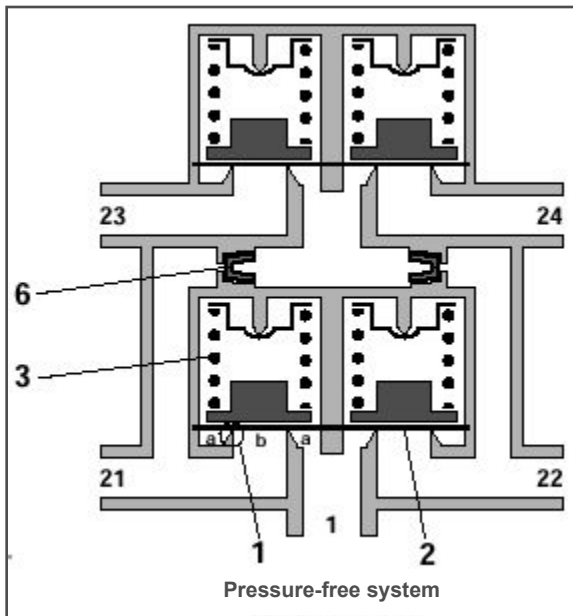

Parallel

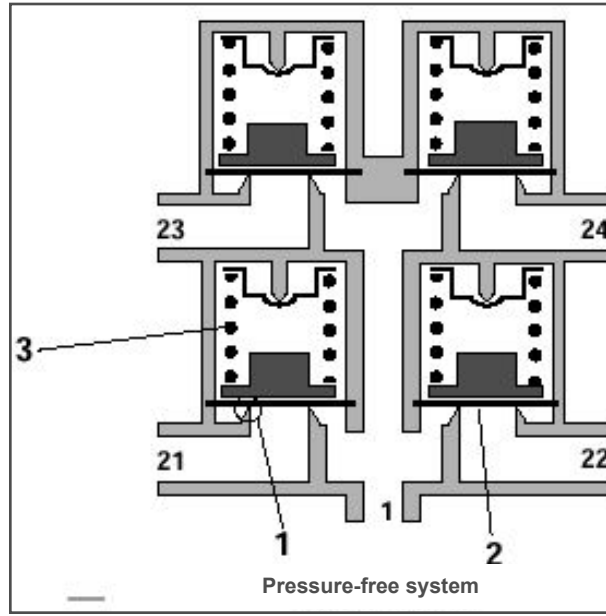

With auxiliary function

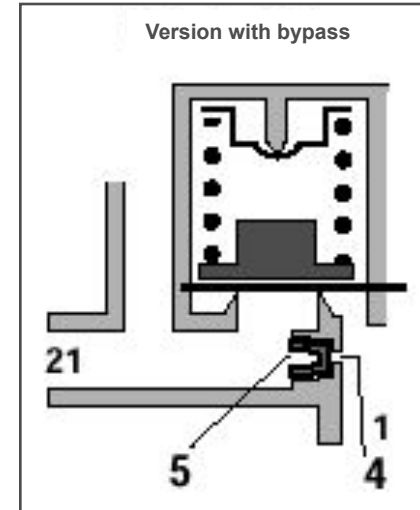

When installing, take care to install it with the spring case facing downwards.

During servicing activities care must be taken that the connections of the connectors are not interchangeable.

In the case of the circuit with a higher air consumption, where there is no air reservoir in the given circuit, short circuit closures can happen.

Air treatment system

Parallel four-circuit protection valve (AE4170) without priority

Pressure-free system

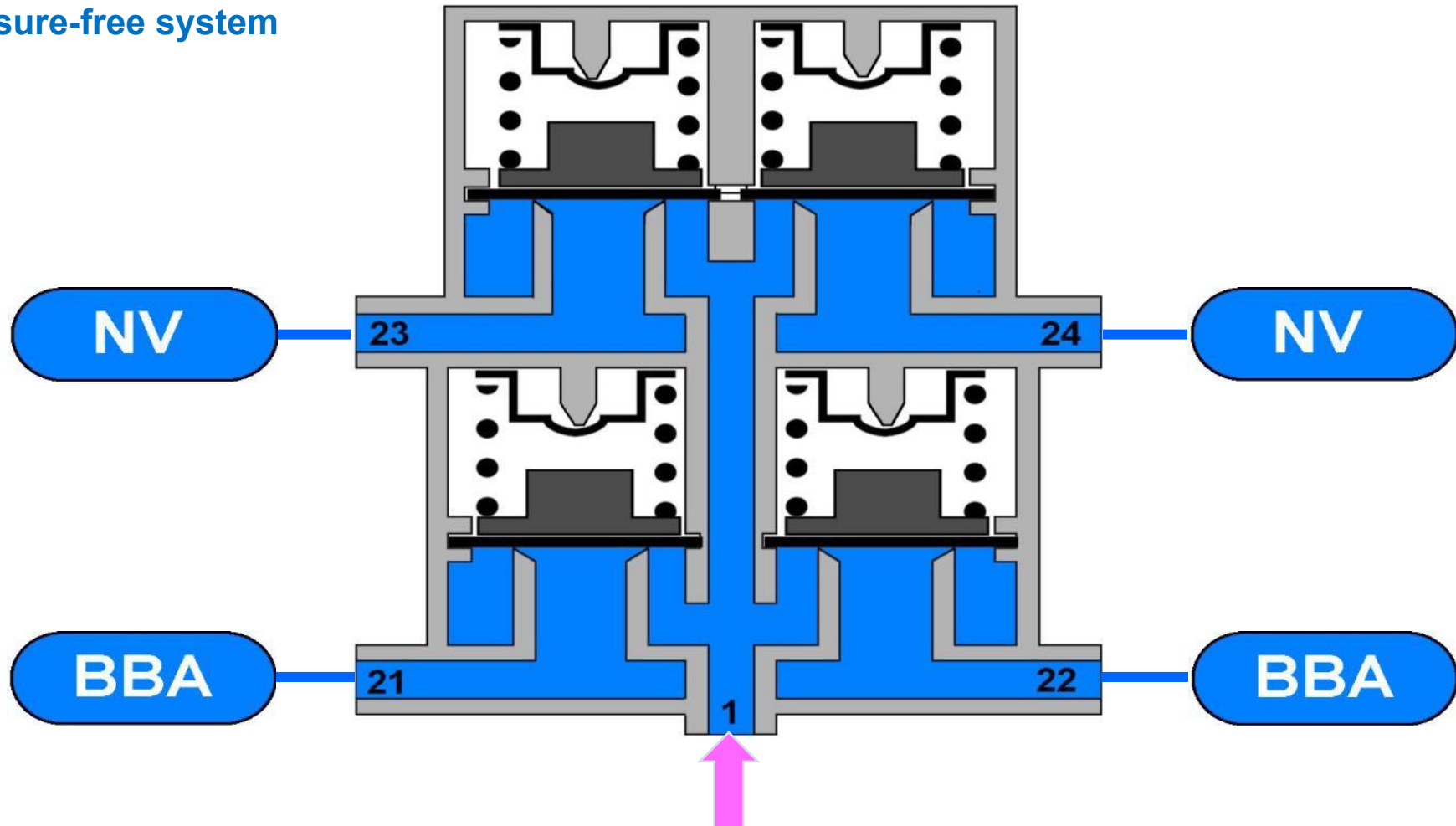

Air treatment system

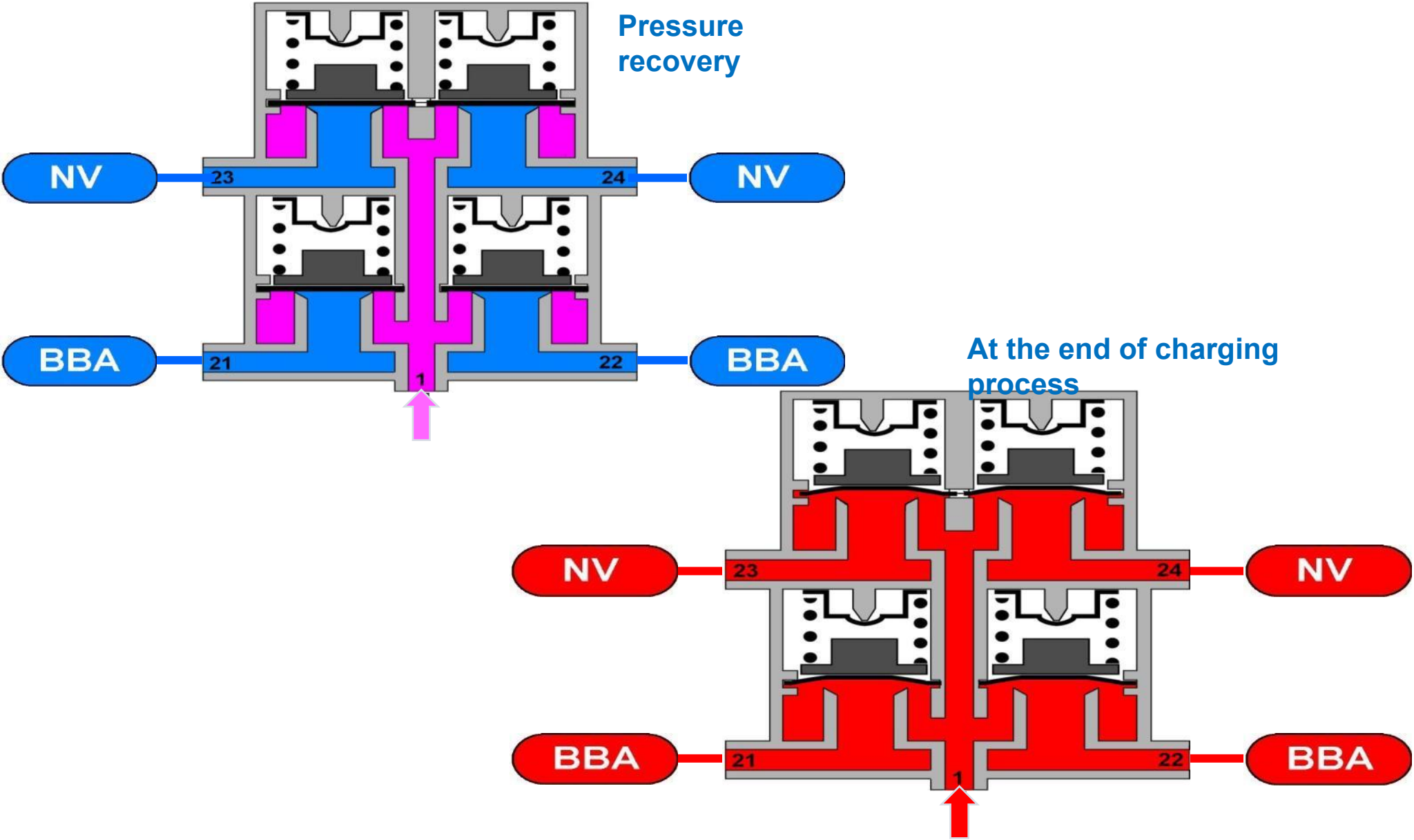

Air treatment system

In the case of circuit damage, without recharge

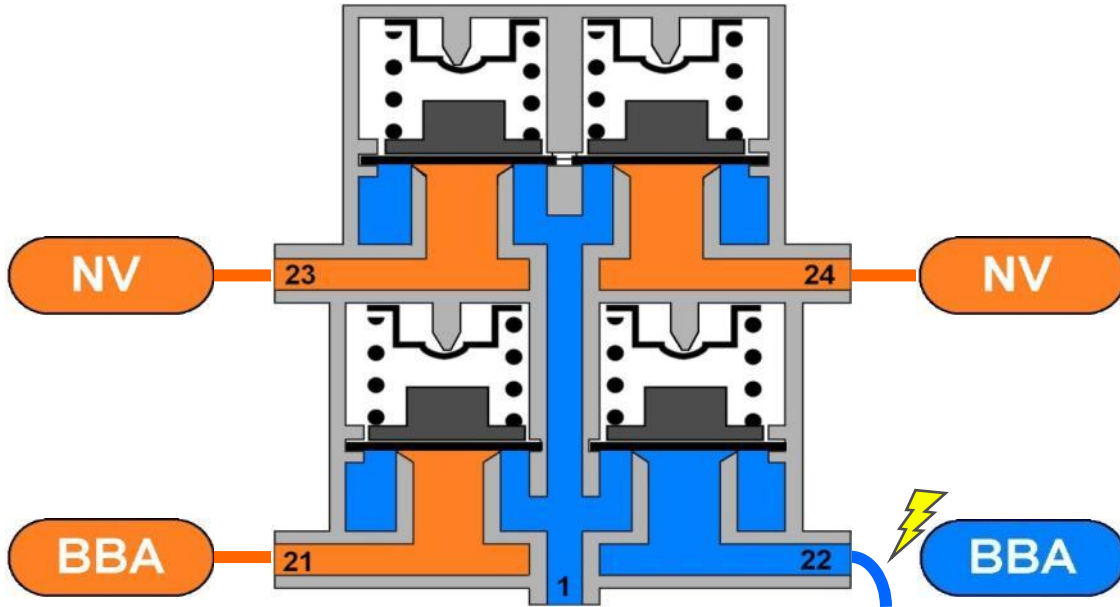

In the case of circuit damage, with recharge

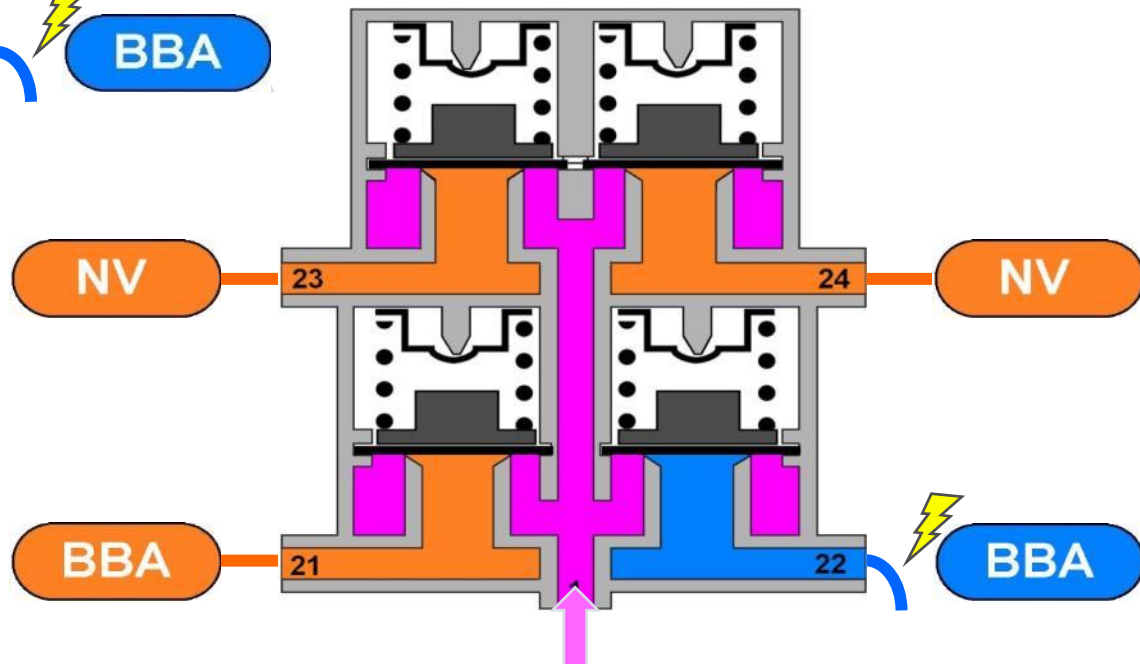

Air treatment system

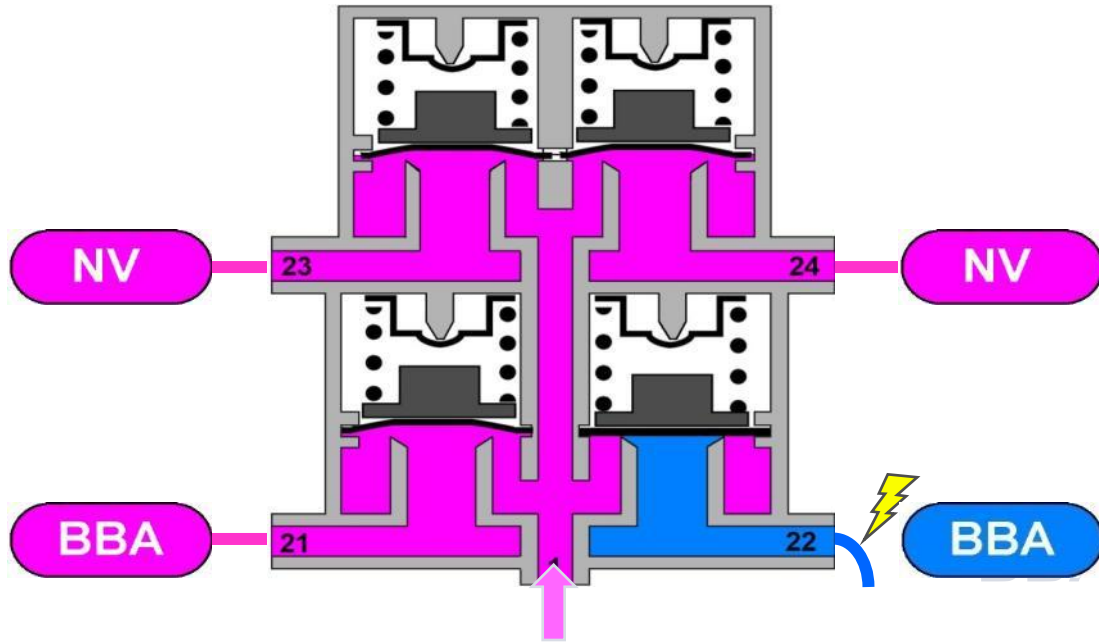

- In the case of recharge, the pressure of undamaged circuits can increase up to the opening pressure of the damaged circuit.
- This is called secured pressure.

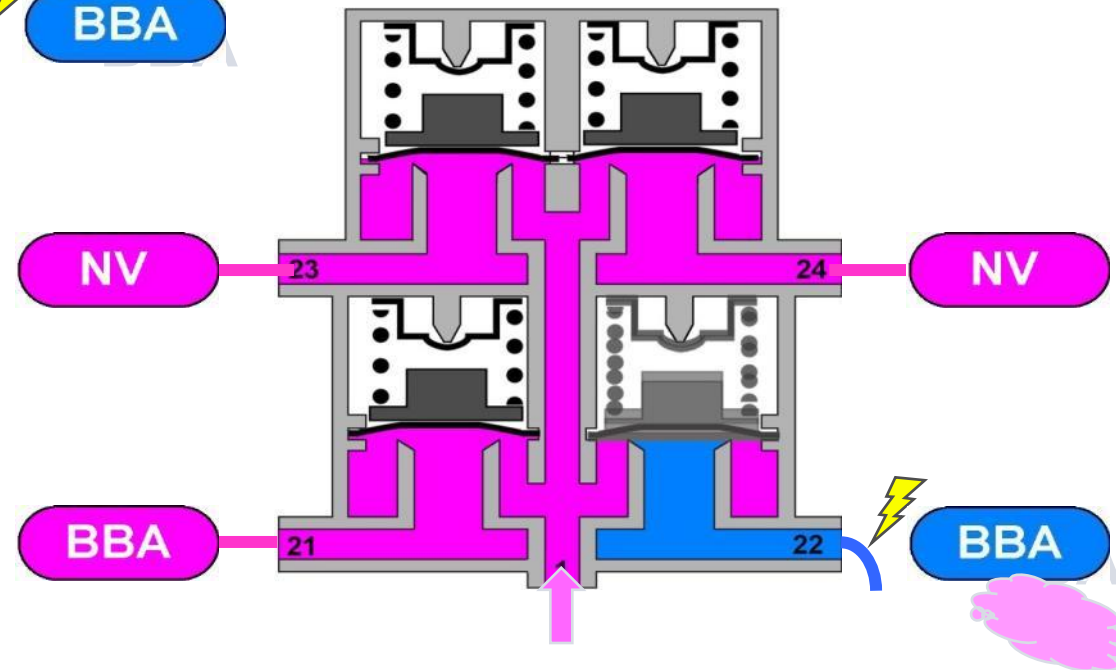

Air treatment system

Line four-circuit protection valve (AE4158)

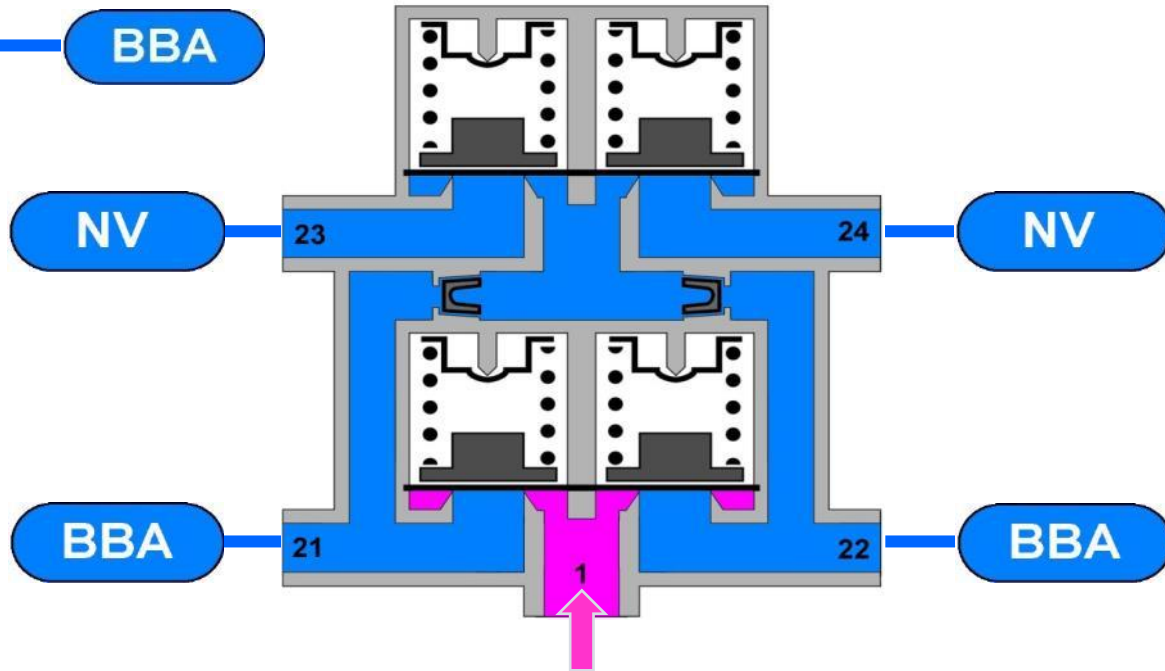
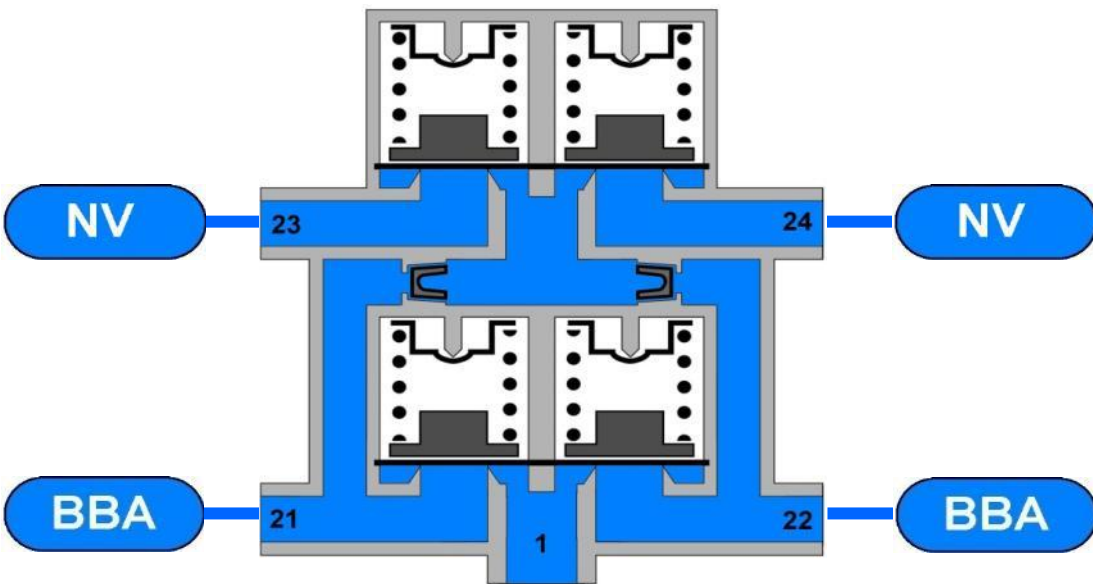

Air treatment system

Partially charged circuit II with which the residual braking performance (

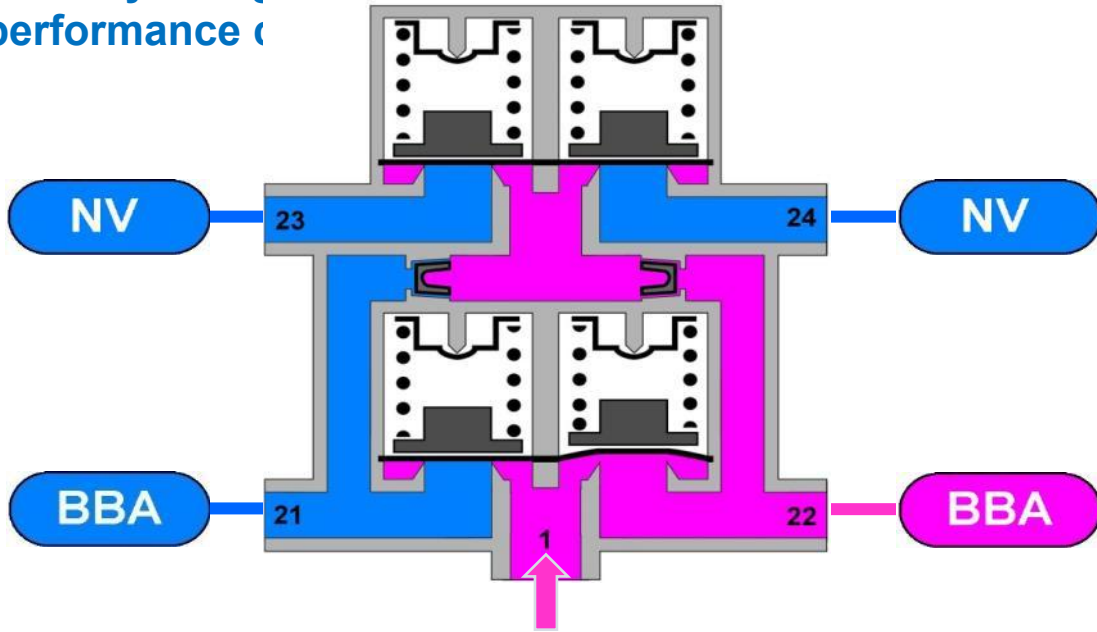

Ring "K" ensures the two independent operating circuits

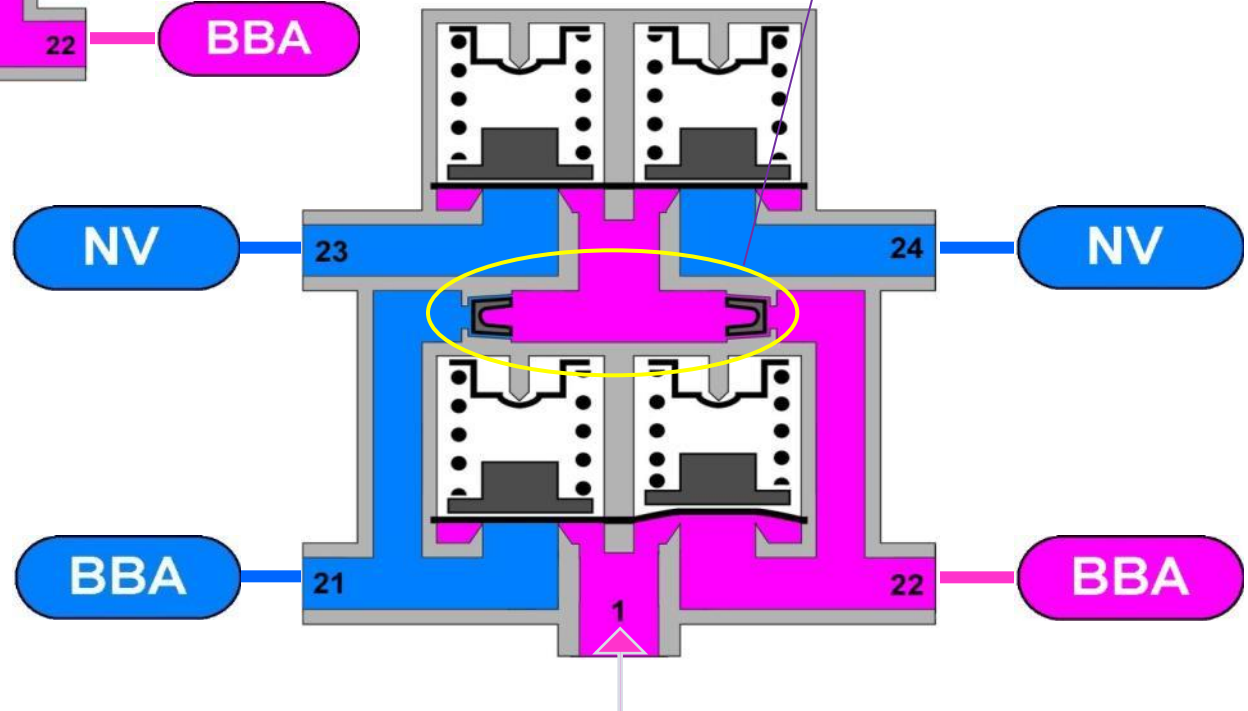

Air treatment system

Charged operating circuits

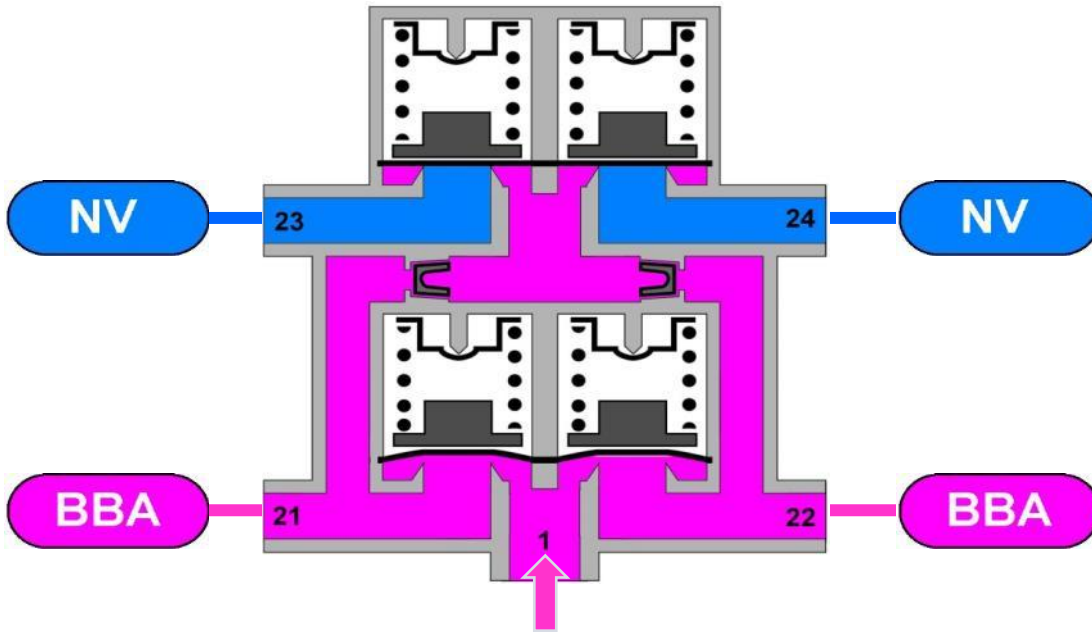

Fully charged system

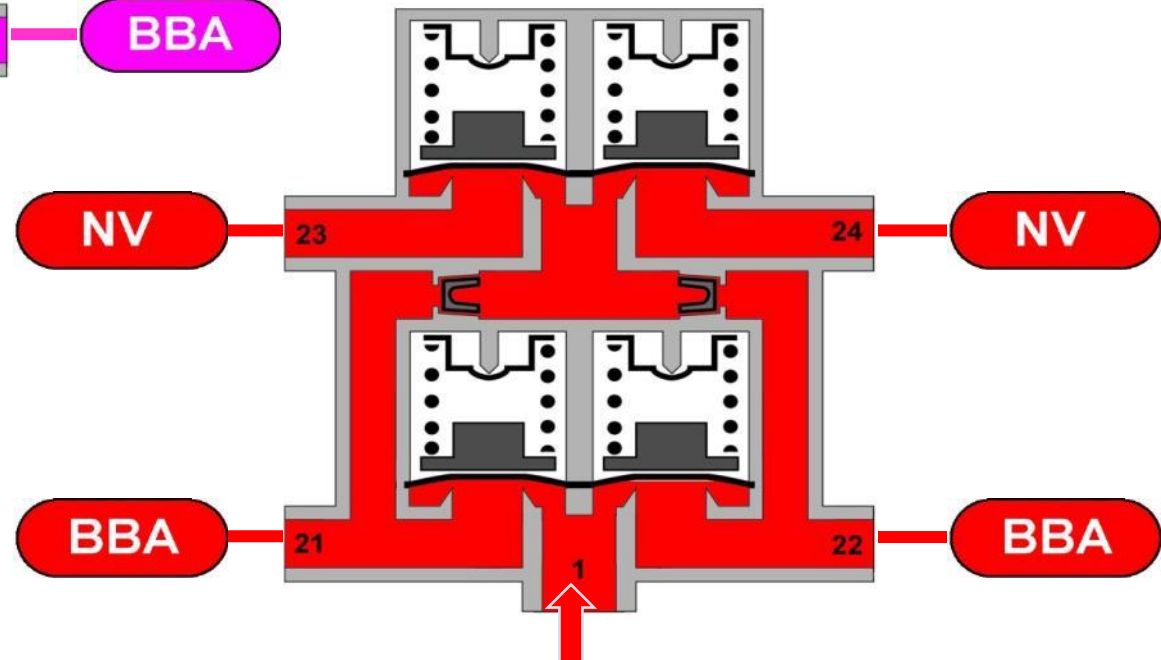

Air treatment system

Circuit 22 is damaged and there is no recharge

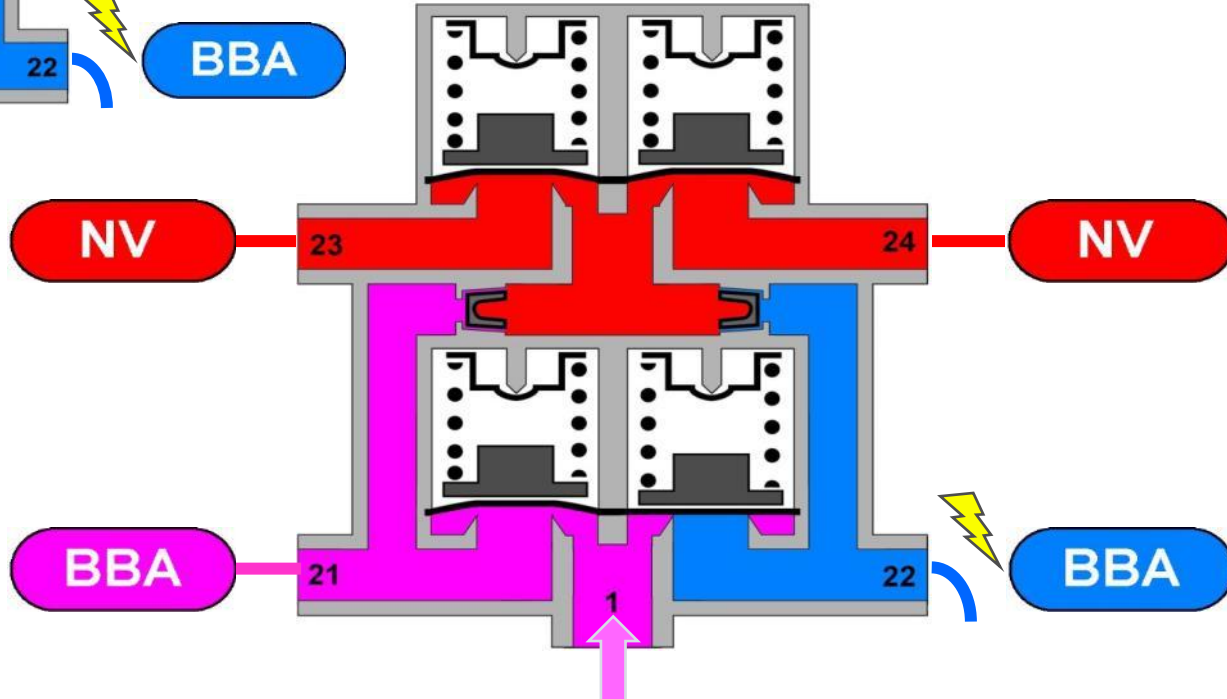
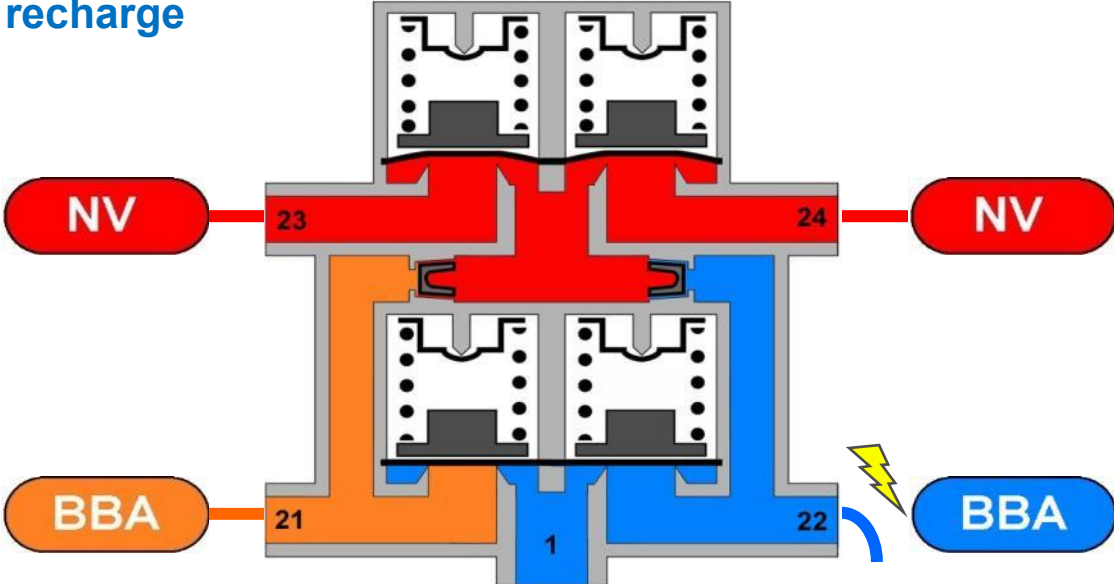

Air treatment system

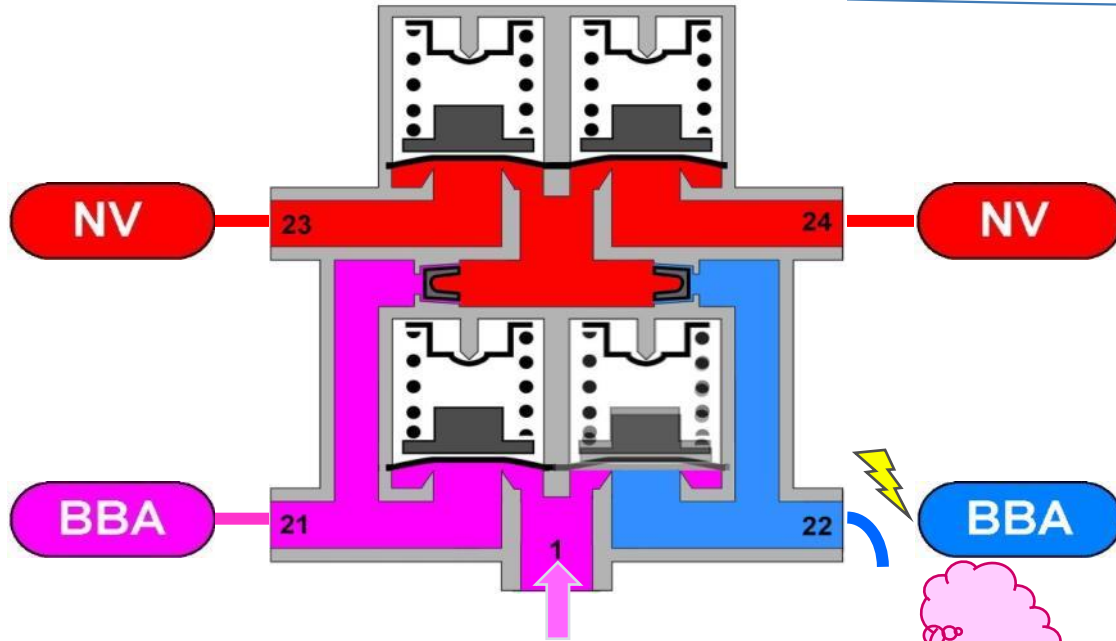

- The undamaged circuit can be charged up to the opening pressure of the damaged circuit
- This is called secured pressure level.

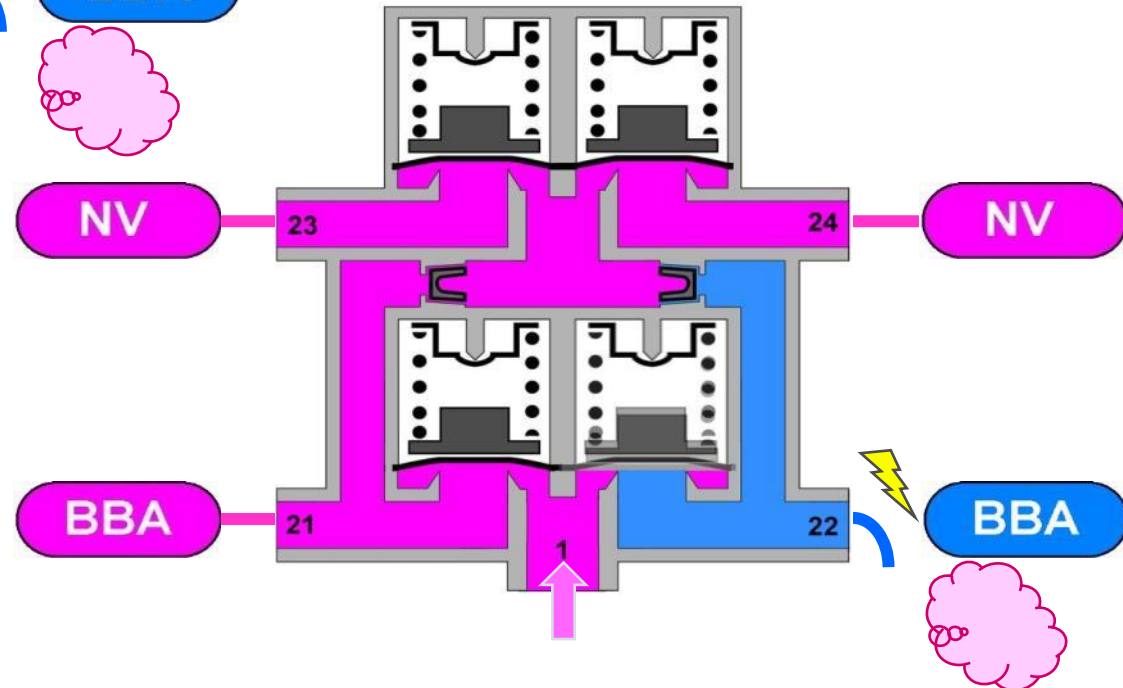

Air treatment system

With a damaged operating circuit, the system cannot be charged if the opening pressure of the damaged circuit is low

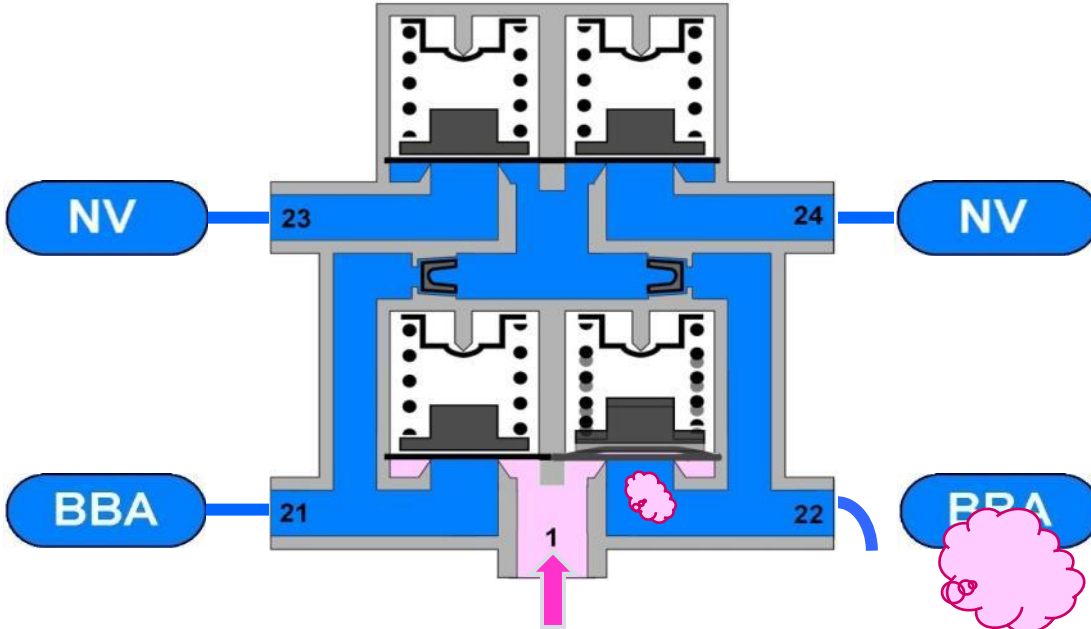

The system can be charged with the help of a bypass

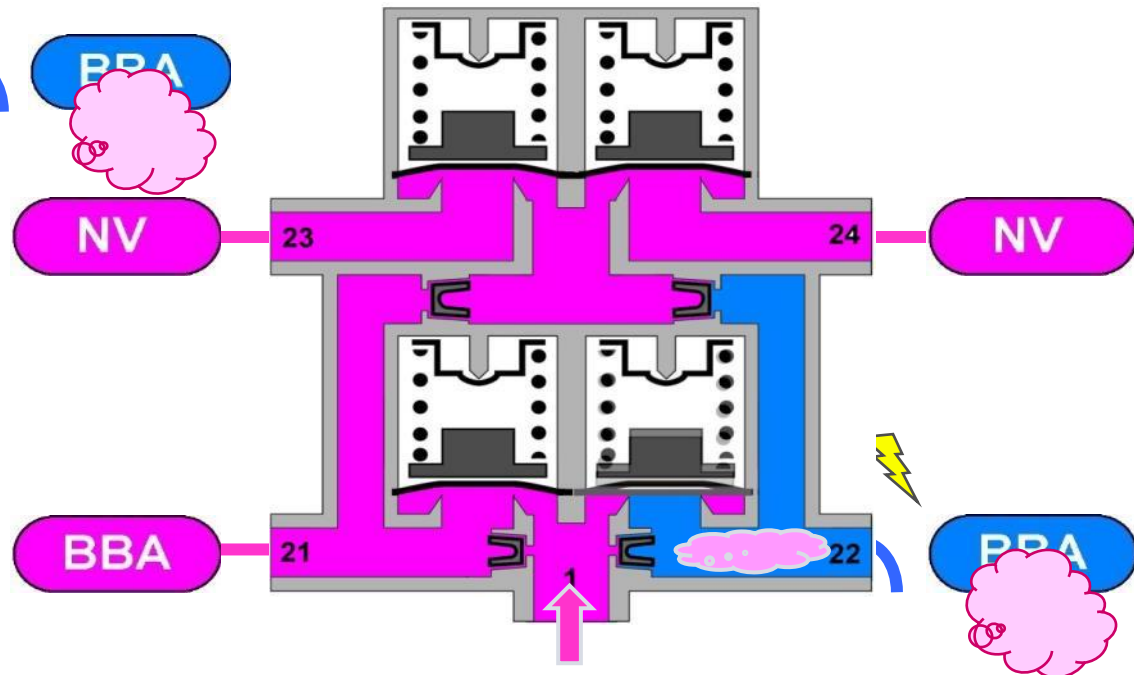

New four-circuit protection valves according to EG-R 98/12 (AE46..; AE48..)

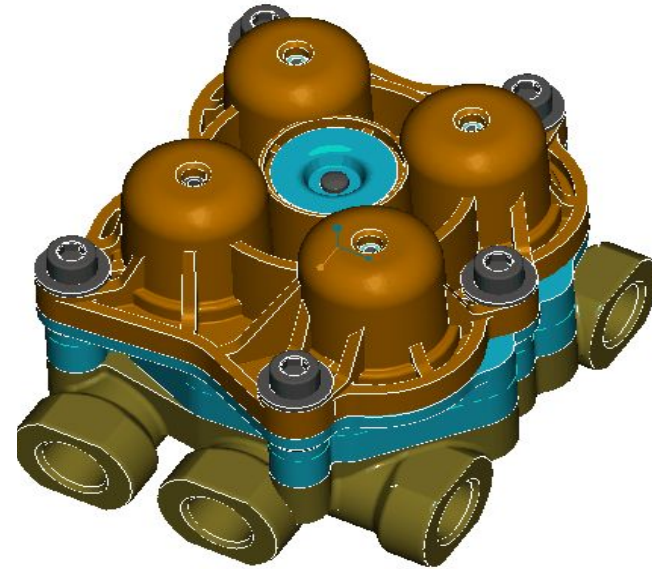
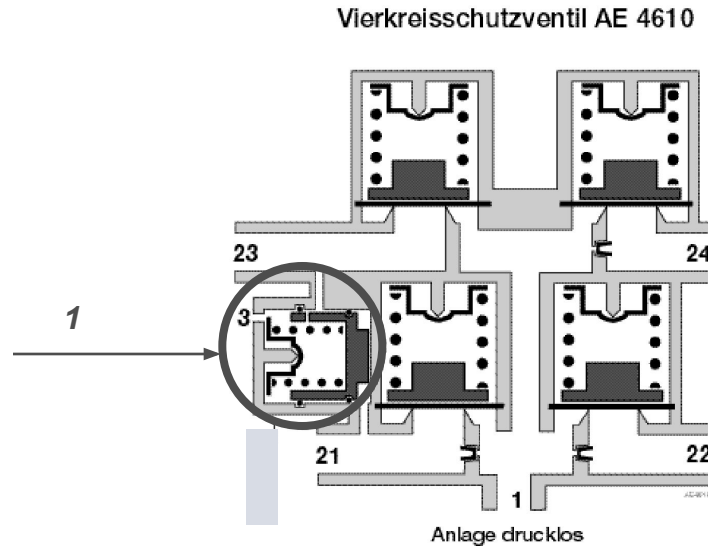

In the case of a damaged operating brake circuit, an operated parking brake system can only be released if the pressure in the operating brake system will once again reach the level of the residual braking performance (13%) (RREG 98/12).

This is ensured with the help of a throttle valve (see Arrow 1) that releases the pressure from the operating brake circuit into the open through Connector 3 (see Arrow 2). This can be clearly heard, it is not a malfunction of the valve.

Thus, as a prerequisite, there should be a pressure reduction in the operating brake circuit.

The throttle valve can be controlled from both operating brake circuits No. 1 and 2.

Air treatment system

Charging of the system

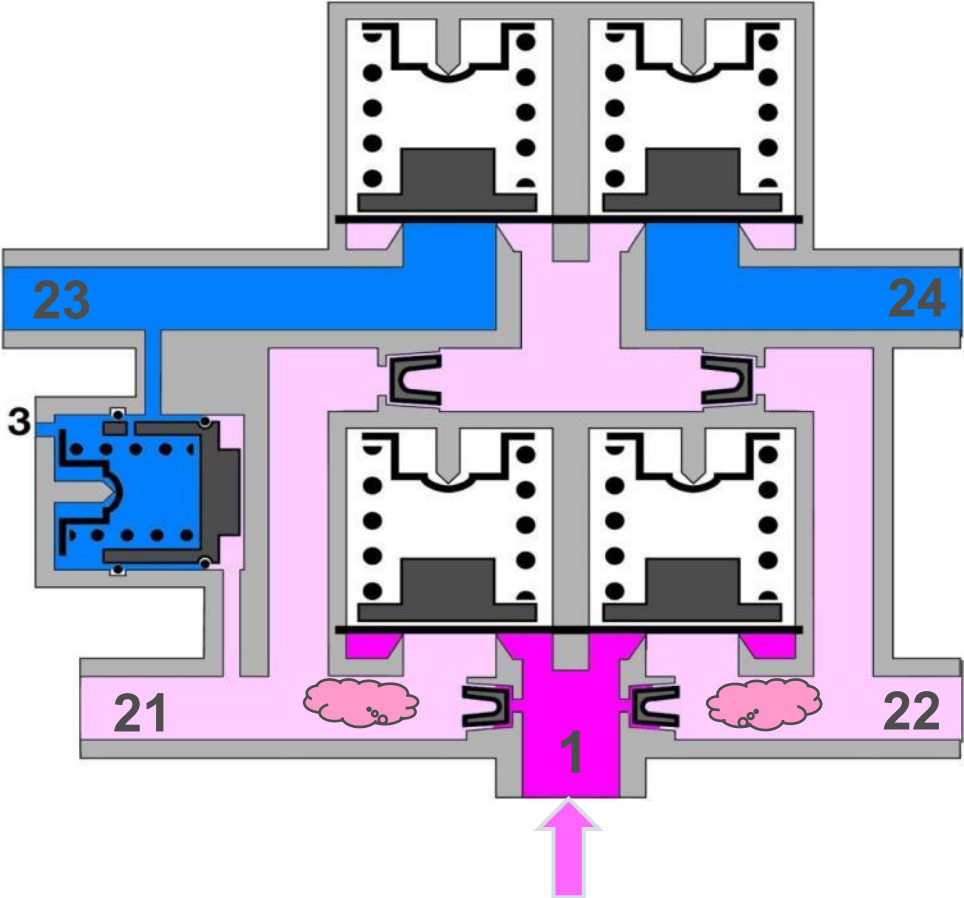
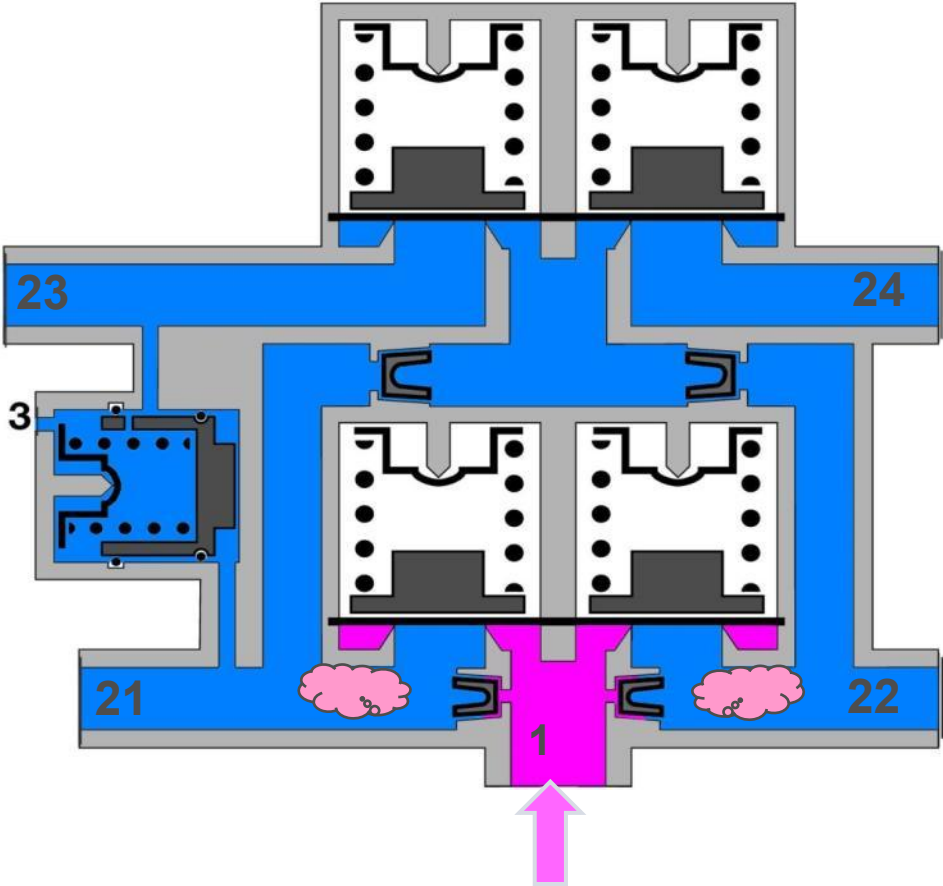

Air treatment system

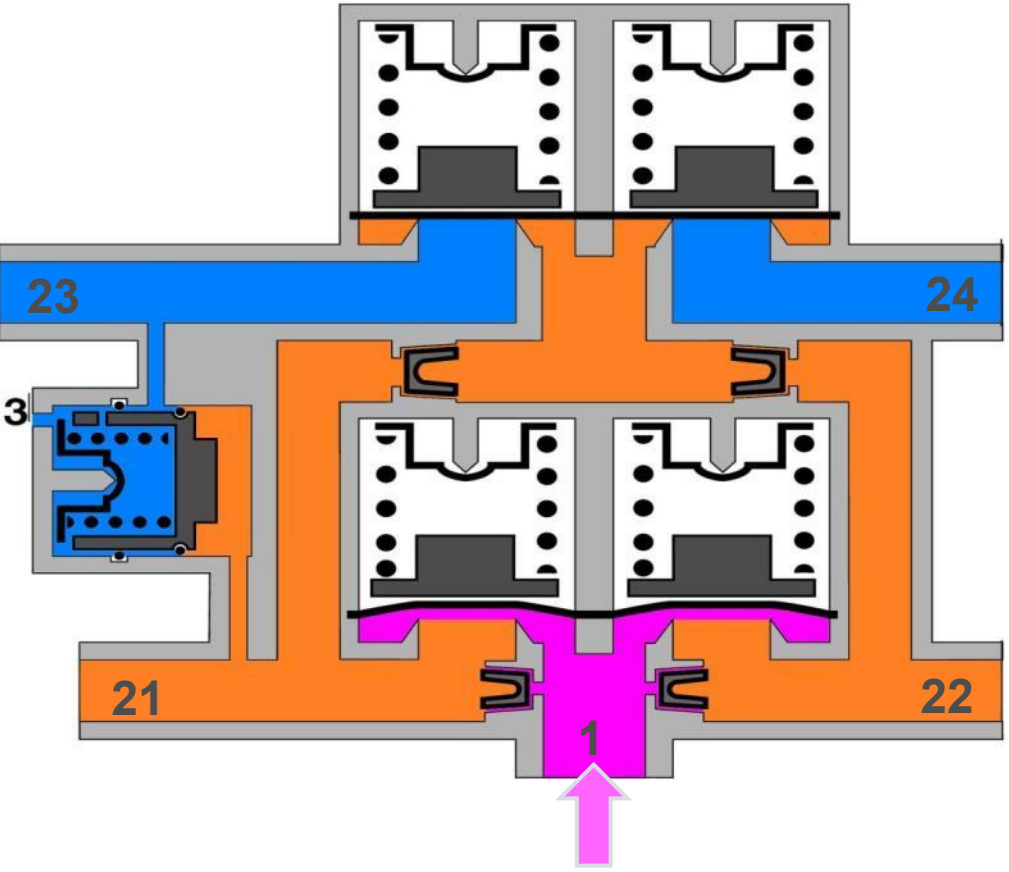

Full charging of the system

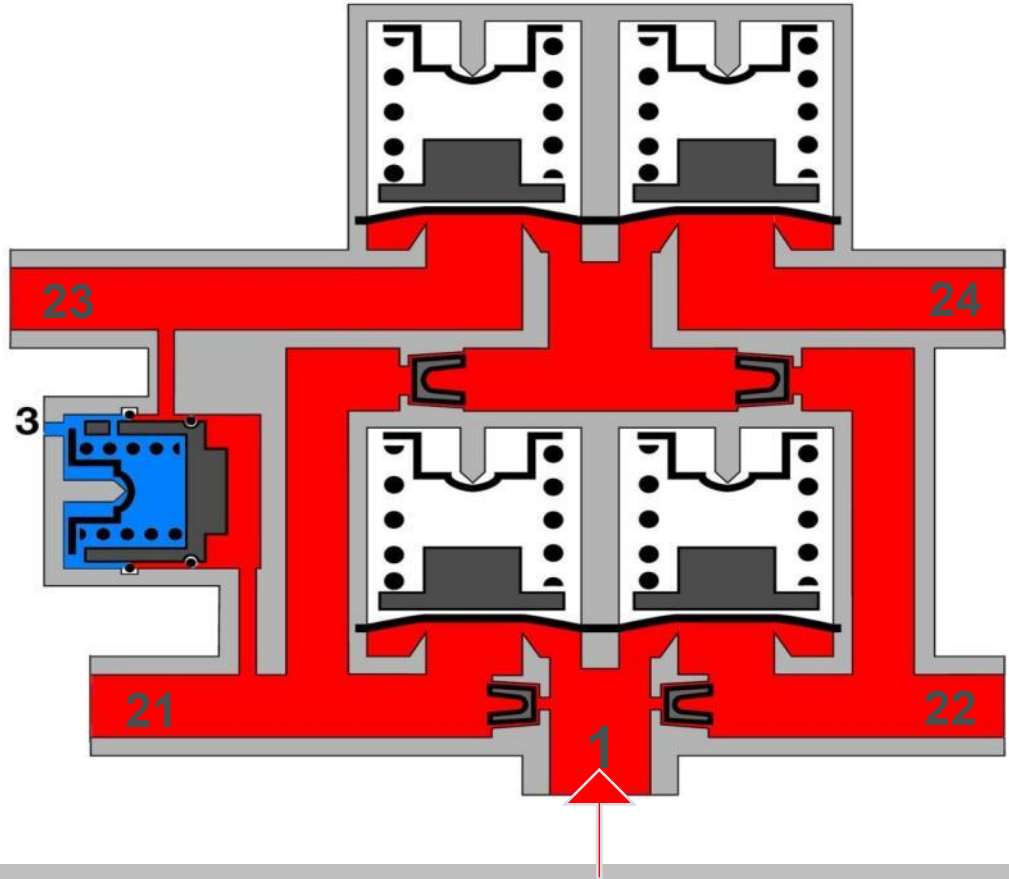

Air treatment system

Operating the brake circuit in the case of “failure”, without charging

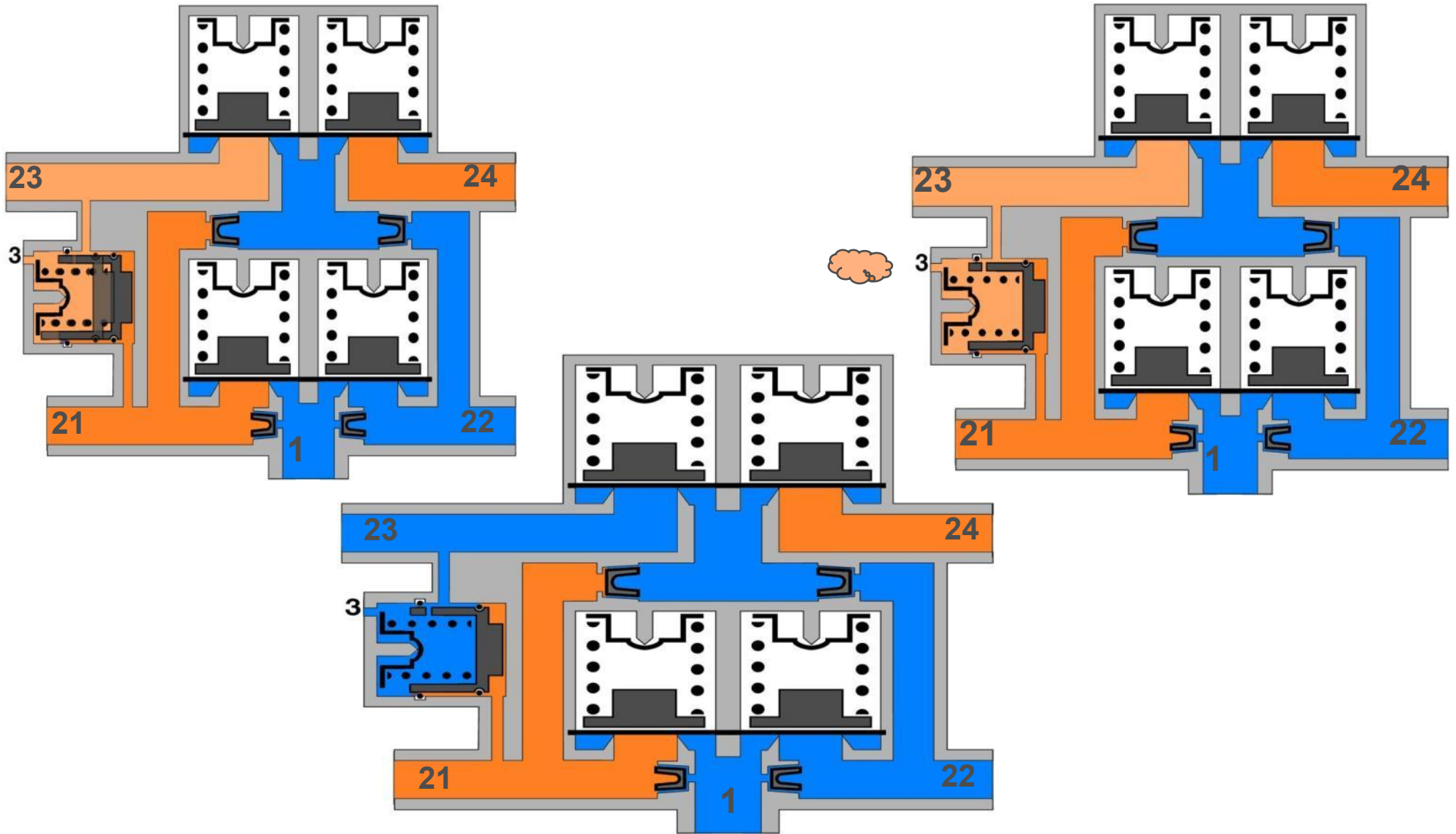

Multi-circuit protection valves



AE46

Independent or can be installed in an air treatment unit with integrated exhaust valve

- 4 outlet connectors
- Optionally: Dual pressure sensor



AE48

Independent or can be installed in an air treatment unit with integrated exhaust valve

- 8 outlet connectors
- With a pressure limiting valve for back circuits
- Optionally: Dual pressure sensor



AE45 /47

Independent or can be installed in an air treatment unit with integrated exhaust valve

- Max. 9 outlet connectors
- Max. two pressure limiting options for the front and back circuits
- Optionally: Dual pressure sensor

Air treatment system

Operation of AE45..

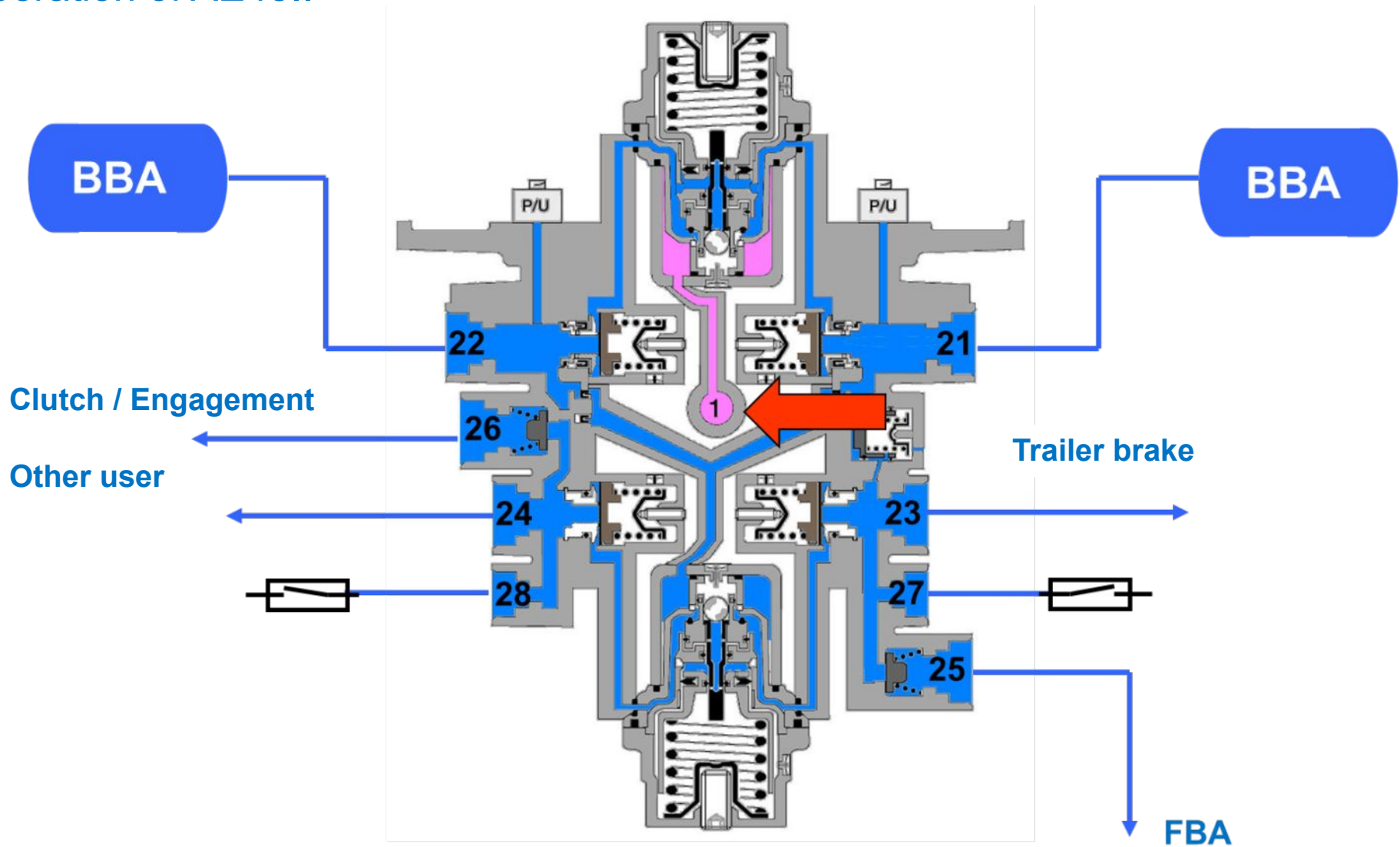

Air treatment system

Operating circuits are open

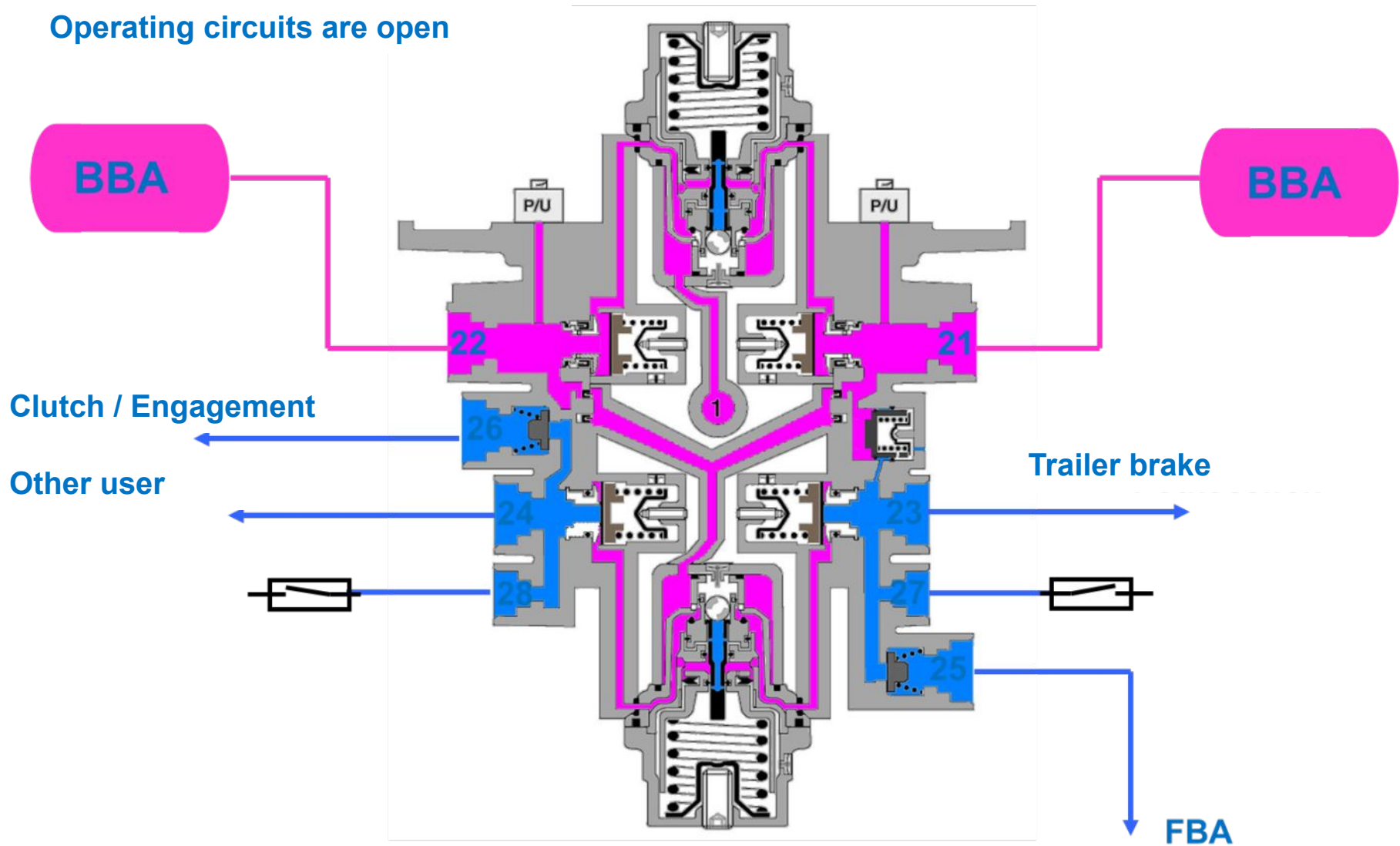

Air treatment system

The pressure limiting valve starts operation at a pressure of 8.5 bars.

The pressure does not increase any more in auxiliary circuits.

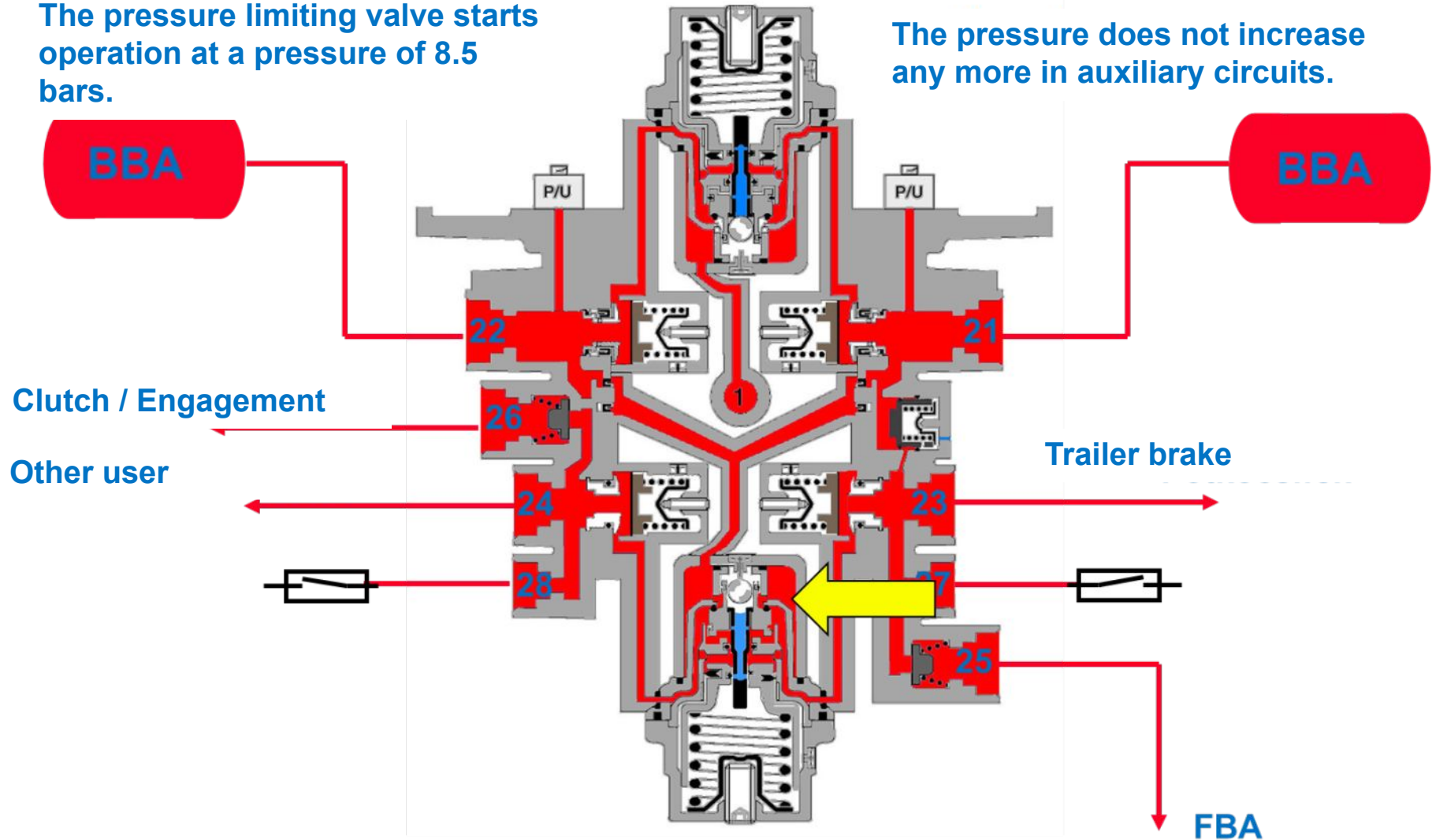

Air treatment system

At a pressure of 10 bars the pressure limiting valve of operating circuits close.

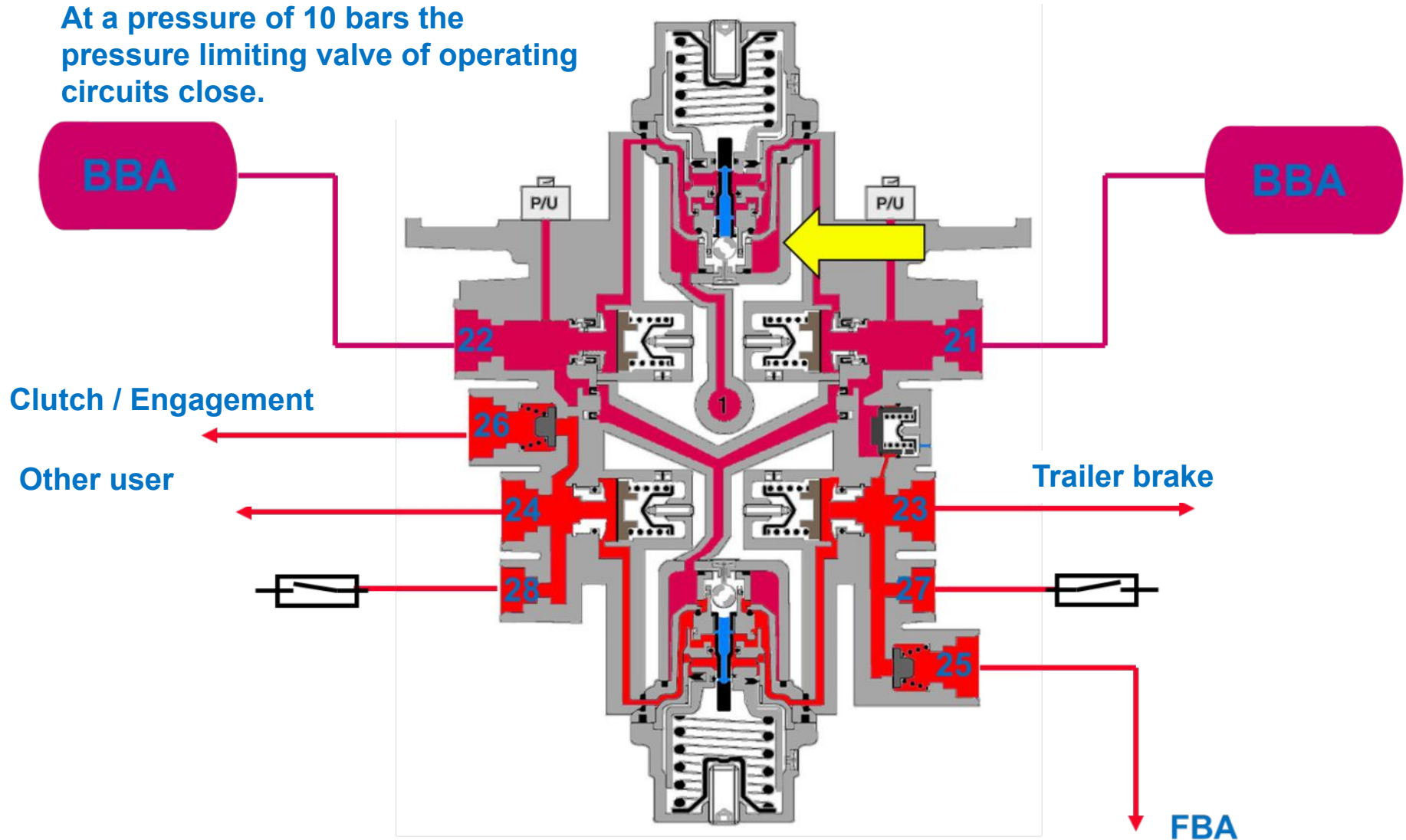

Air treatment system

Pressure level of inlet connector reaches 12.5 bars.

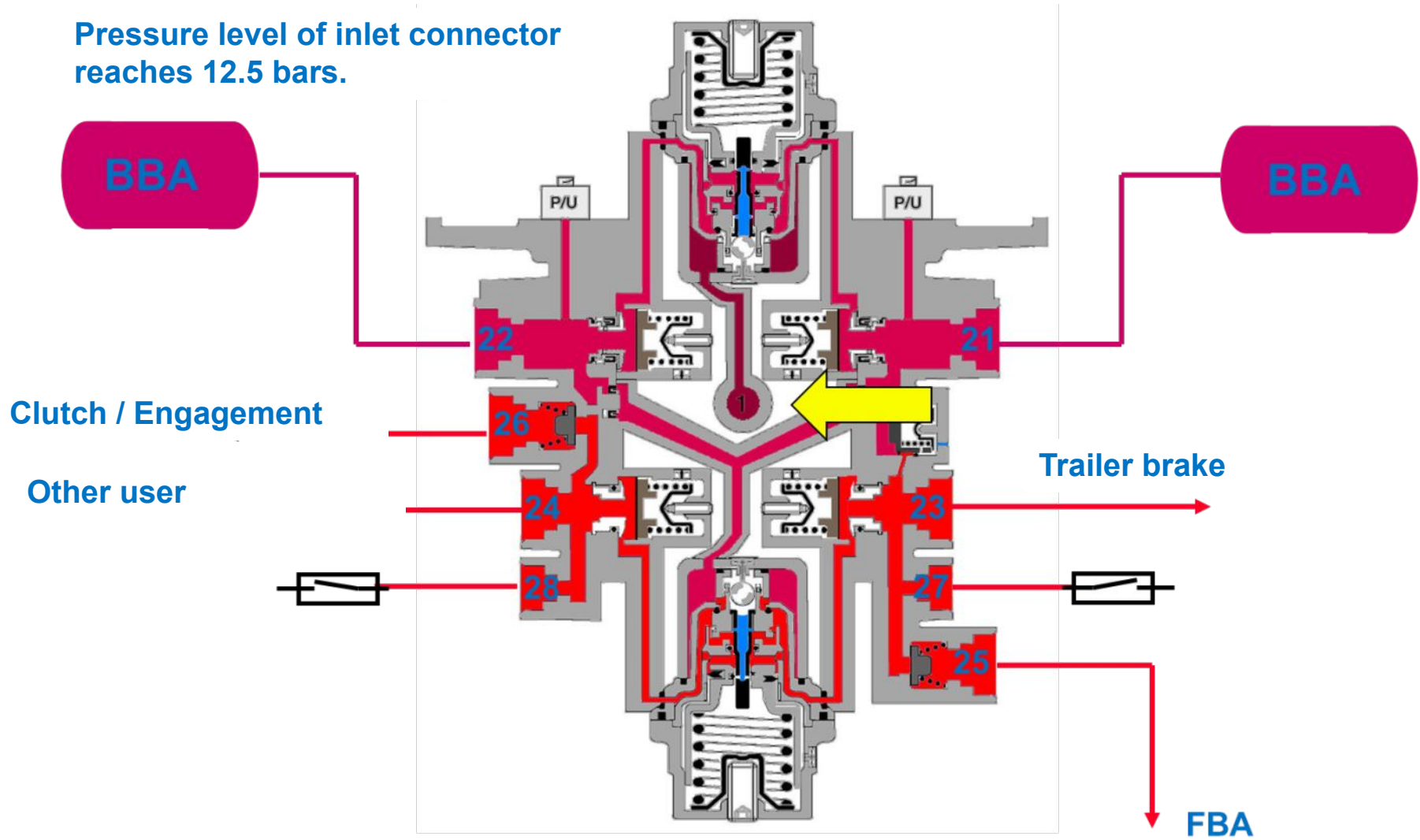

Air treatment system

Four-circuit protection valves – Current service information



Air treatment system

Overview table of air treatment units (ZB45.., ZB46.., ZB47..; ZB48..; ZB44)

ZB46..



1 pressure level

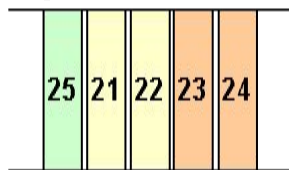

ZB48



2 pressure levels

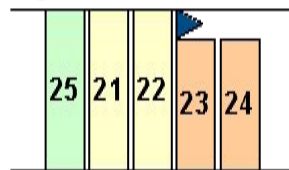

ZB45/47



3 or 2 pressure levels

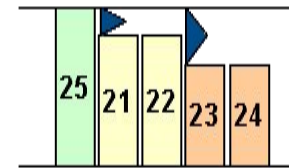

ZB44



1 pressure level

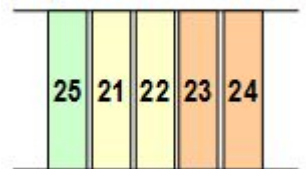

Air treatment system

Complex air treatment units – Current service information



Air treatment system

Summary of necessary service activities:

Compressor:

- condition of air filter
- condition of suction pipe
- tension of V-belt
- condition of pressure tube
- air delivery
- oil carry-on
- exhausted air temperature

unloader valve

- Controlling the switch-off pressure
- Controlling the switching interval

Air dryer:

- Quantity of condensate in air reservoirs
- Condition of the cartridge
- Controlling the switch-off pressure
- Controlling the switching interval
- Percentage of delivery and regeneration phases
- In the case of cartridge replacement, the cartridges of appropriate thread size and thread direction must be used