



LONWIL

НАДЕЖНЫЙ ПРОИЗВОДИТЕЛЬ И
СЕРЬЕЗНЫЙ ДЕЛОВОЙ ПАРТНЕР

L



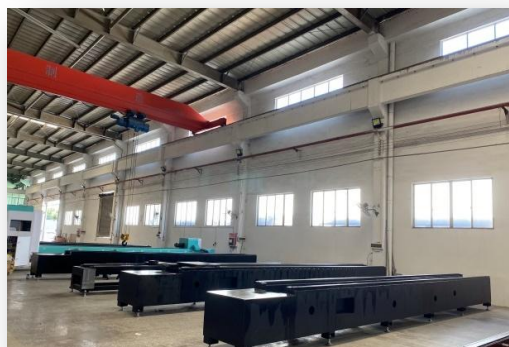

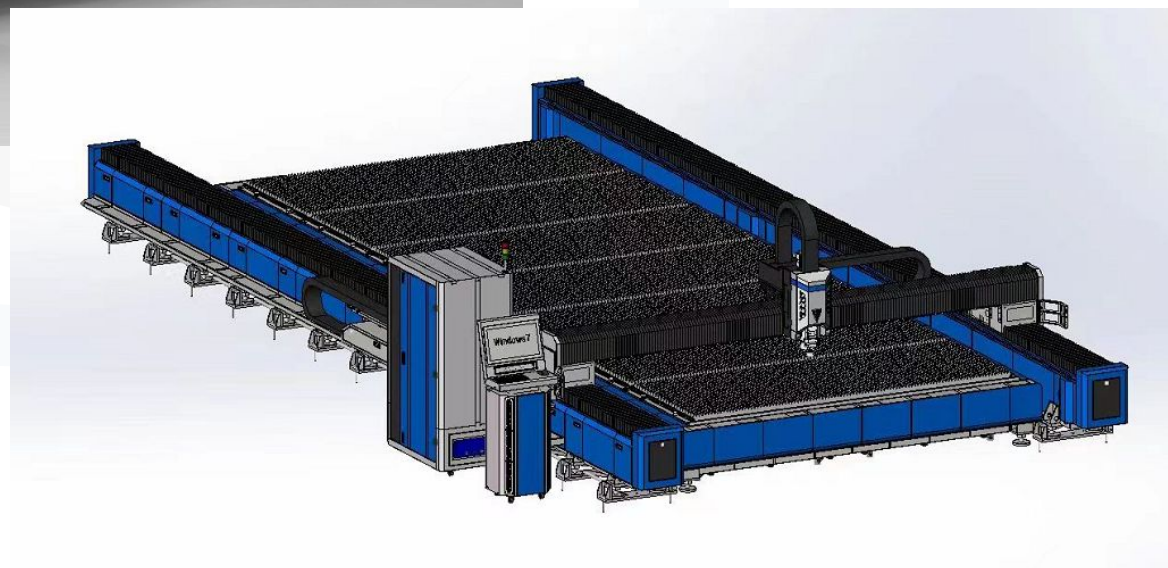

Станок для резки толстолистового металла BIG FORMAT-BIG POWER

[Redacted text block]

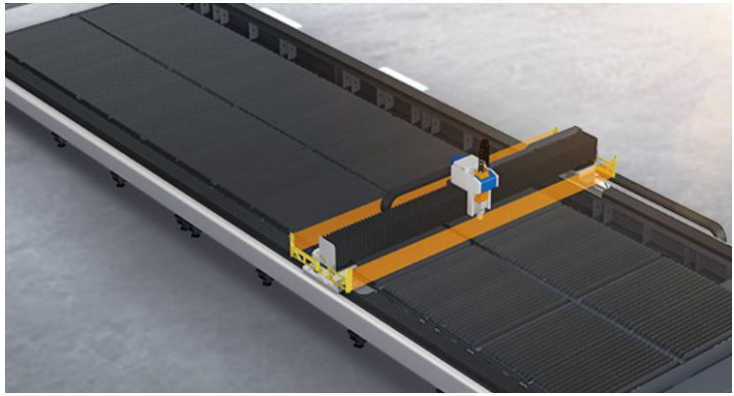
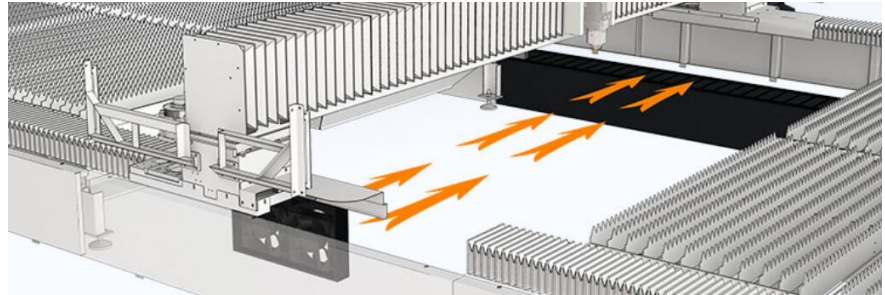

[Redacted text block]

[Redacted text block]





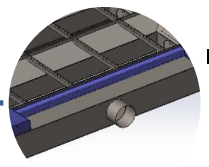
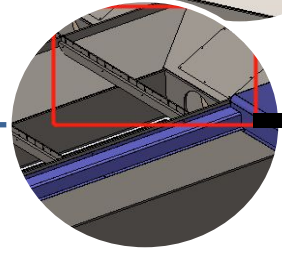
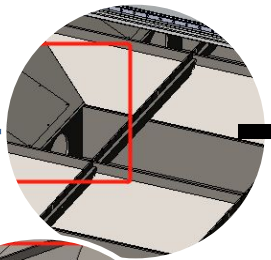
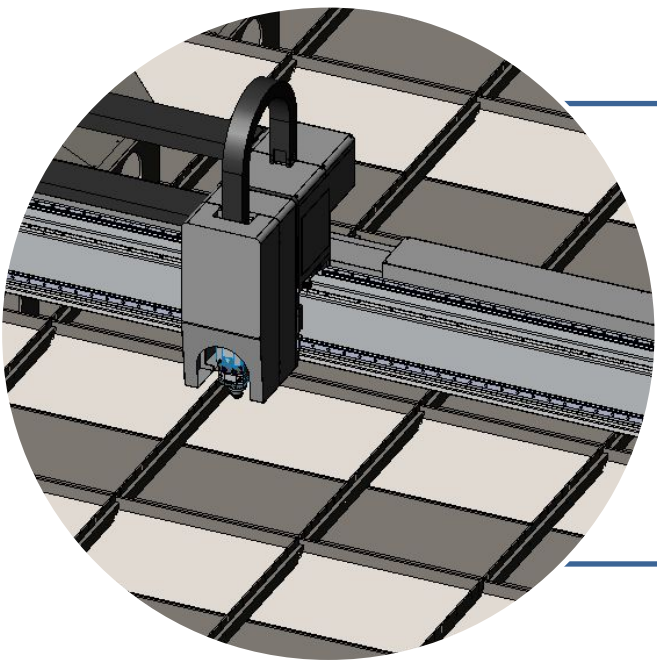

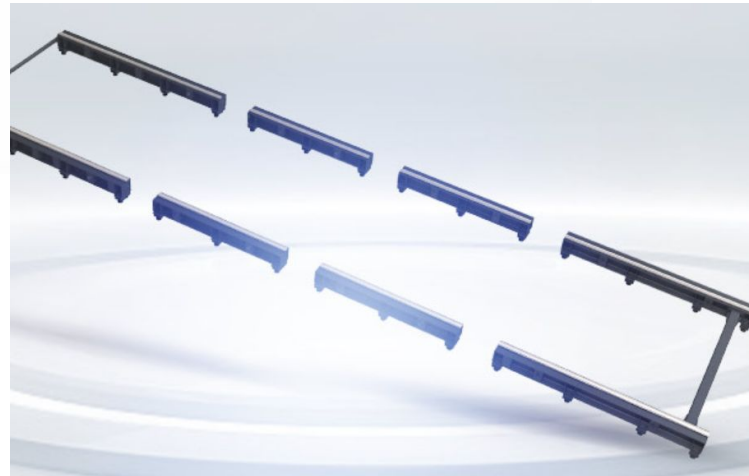
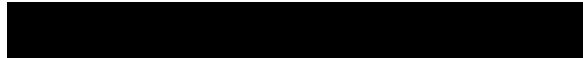
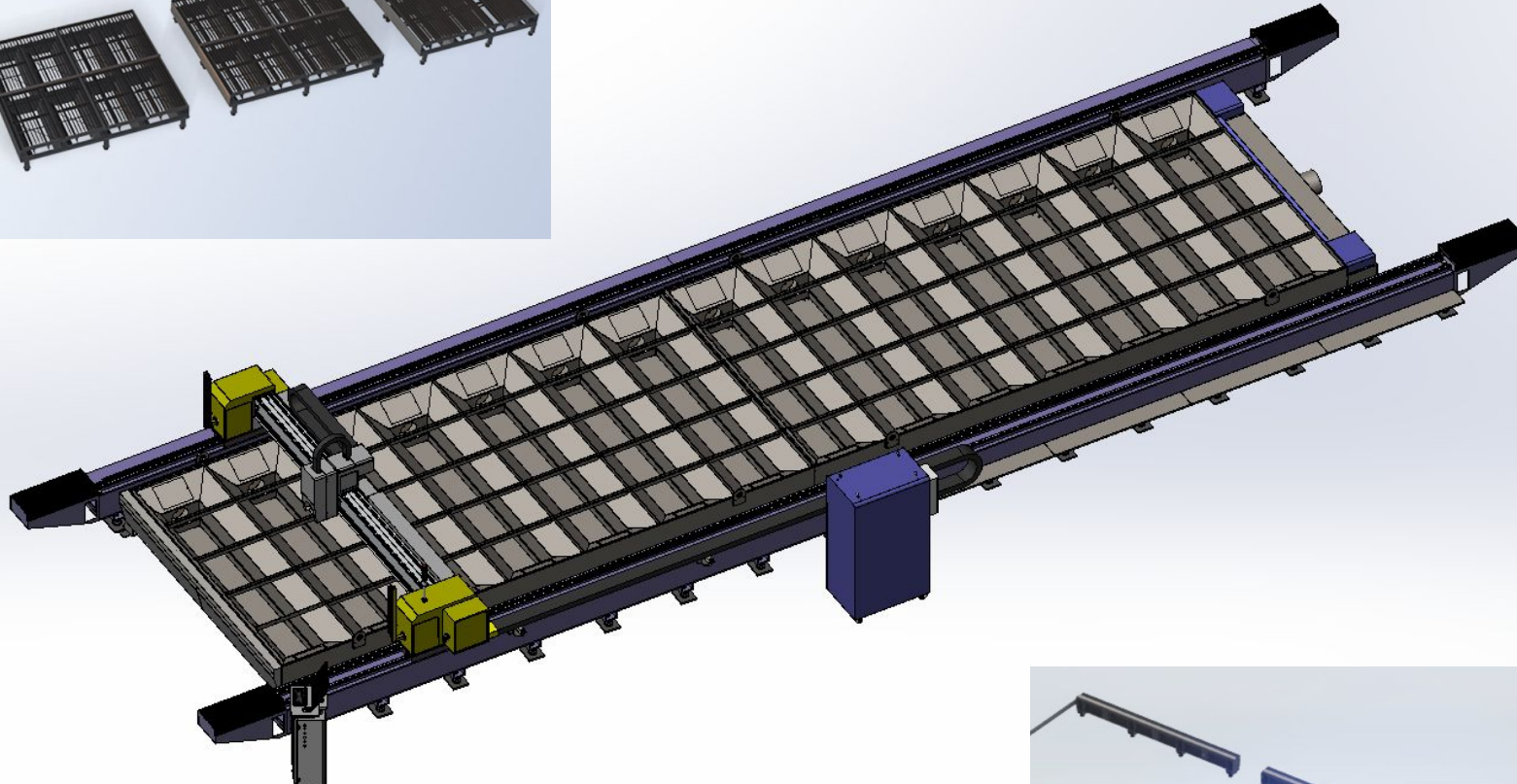

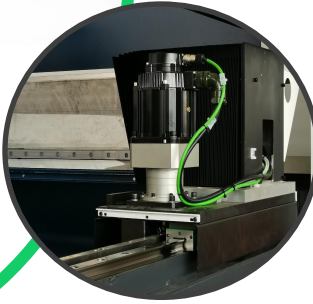
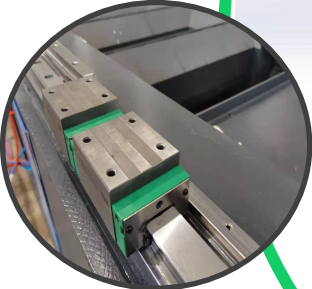
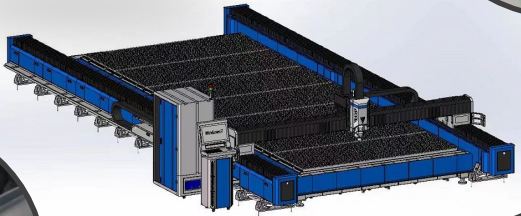
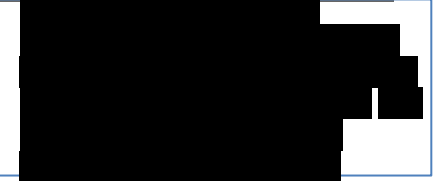
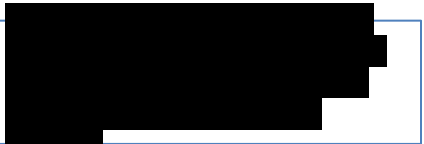
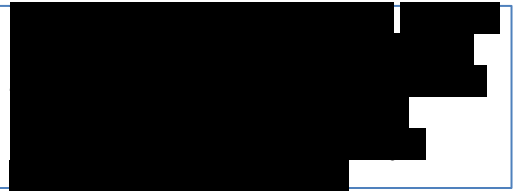



Примечание: сварные соединения без отжига быстро разрушаются со временем и не обеспечивают высокой прочности при работе 24 часа в сутки, 7 дней в неделю.

[REDACTED]



[REDACTED]



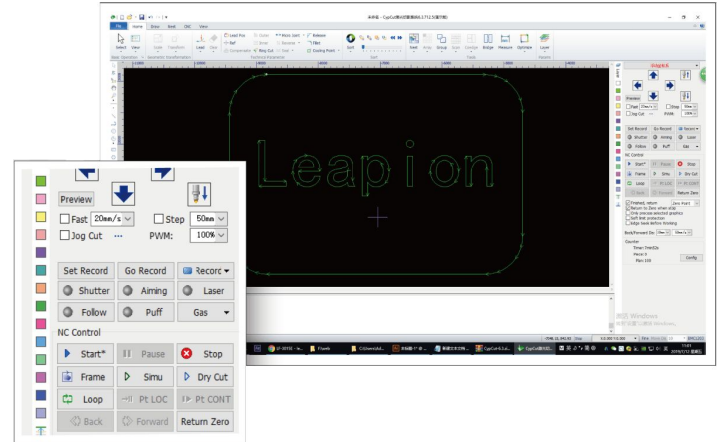

Усовершенствованная версия--

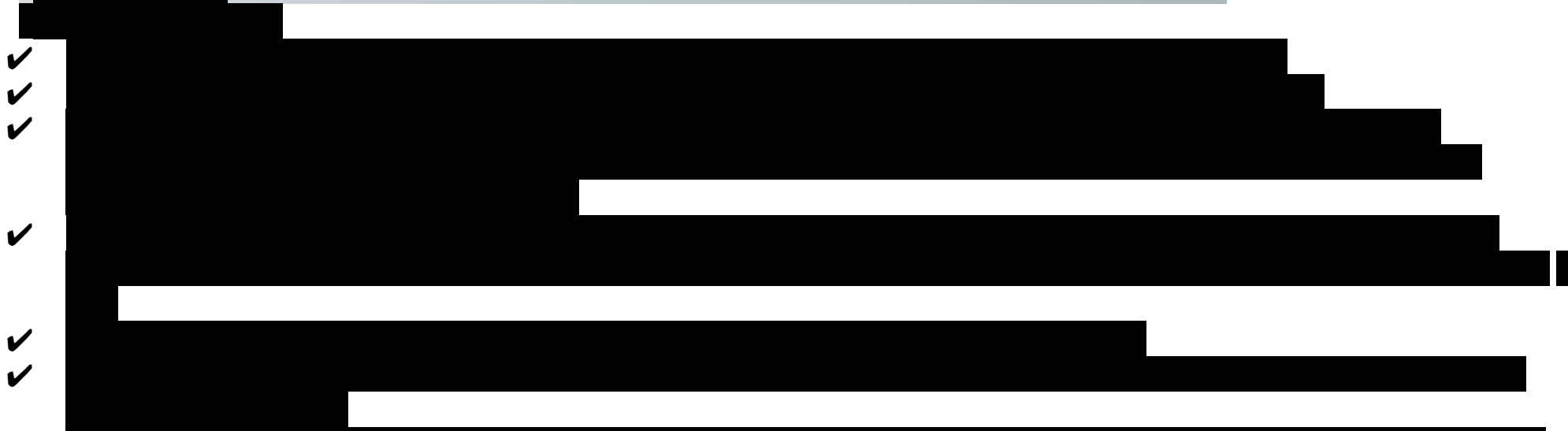

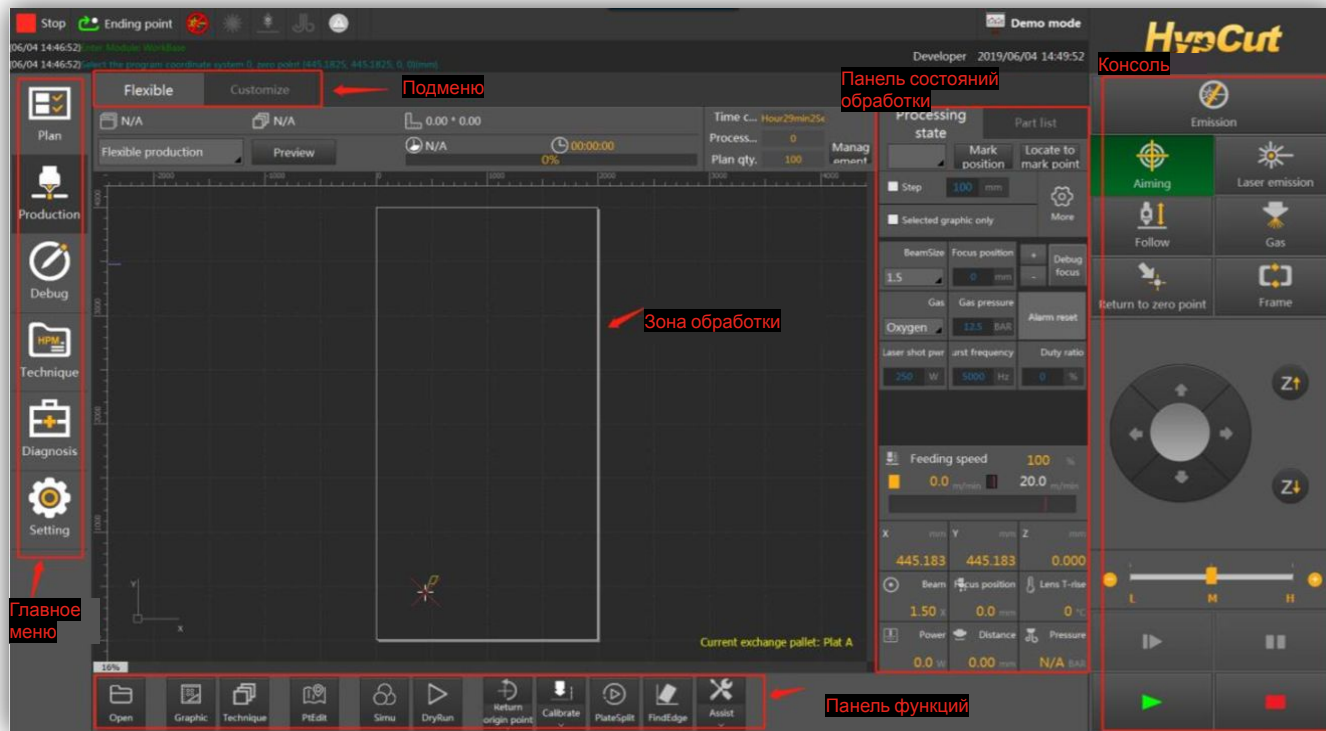

- **Интеллектуальная диагностика:** Контроль, запись состояния станка и отображение стандартных инструкций по устранению неисправностей упрощают удаленную диагностику.

- **Удобство технического обслуживания** Обеспечивает удобные для пользователя функции, облегчающие техническое обслуживание станка - выполнение калибровки емкостного датчика, точечной коллимации, замены сопла, очистки и прочих операций нажатием одной кнопки.



<p>Machine</p> <p>Rigid grade: 17 Firmware version: 1</p> <p>Feedback coordinate X: 0.000mm Feedback coordinate Y: 0.000mm Double drive axis error: 0.000mm</p>	<p>Input and output</p> <p>Number of IO modules: 0 Number of Input ports: 0 Number of Output ports: 0</p>	<p>BCS100</p> <p>Hardware Version: 0.00 Software version: 0 Following level: 18 Calibration range: 25.00mm Stability: Excellent Smoothness: Excellent Difference value: 0.00 DIF: 0.00 Last calibration date: 21-06-17</p>
<p>Cutting head</p> <p>Type: Focus range: -15.00~5.00mm sensor: Already opened</p> <p>Current focus: 0.00mm Current spot: 0.00X</p>	<p>Laser</p> <p>Type: Raycus Rated power: 1000.00W</p> <p>Current peak power: 50.00% Current frequency: 5000.00Hz Current duty cycle: 10.00% Current average power: 50.00W</p>	<p>Gas</p> <p>Upper limit of gas pressure: 0.00BAR Regulating range of proportional valve: 0~0.00V Gas type: 0</p> <p>Current gas: * Current gas pressure: 0.00BAR</p>
<p>Vision</p> <p>CCD: HikVision Number of cameras: 1</p>	<p>Water chiller</p> <p>Type: Demo Waterway: Double temperature Water temperature: 25°C Flow: 200ml/s</p>	<p>Alarm record</p>

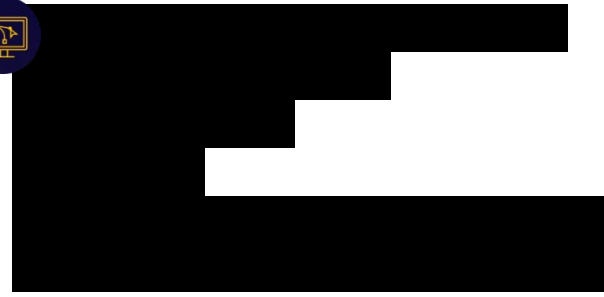

Где бы вы ни находились, всё будет под контролем

✓ 4-8 кВт



✓ 12-20 кВт



✓ 10-12 кВт



Модульная конструкция, устранение неполадок за 5 минут, низкие затраты на техническое обслуживание.



Все линзы готовы к работе сразу после установки, не требуется ремонт на заводе-изготовителе, что упрощает послепродажное обслуживание.

Дополнительное уплотнение, предотвращающее попадание пыли

Система двойных уплотнений класса защиты IP65, успешно прошедших испытание на пыленепроницаемость.

Интеллектуальная полнофункциональная режущая головка, обладающая исключительным соотношением стоимость/производительность и укомплектованная различными датчиками, анализирующими ее состояние.



□

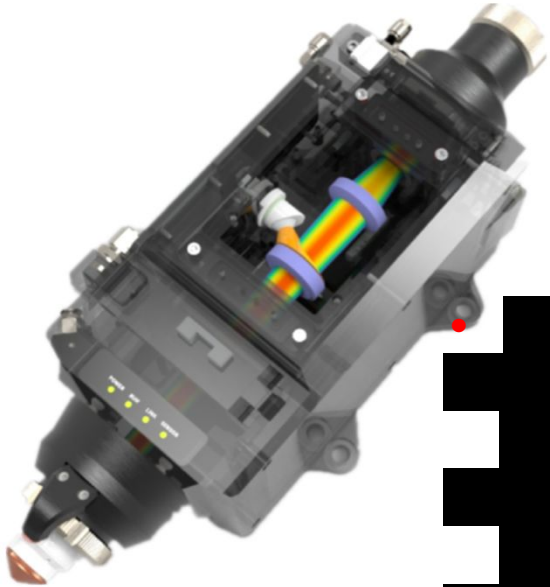

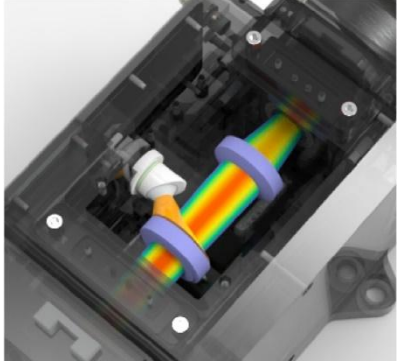
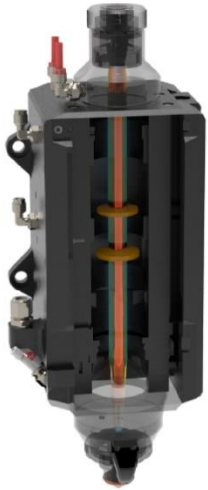



[Redacted text]

[Redacted text]

[Redacted text]

[Redacted text]

[Redacted text]

[Redacted text]

[Redacted text]

[Redacted text]

[Redacted text]

[Redacted text]

[Redacted text]

[Redacted text]

[Redacted text]

[Redacted text]

[Redacted text]

[Redacted text]

[Redacted text]

[Redacted text]

[Redacted text]

[Redacted text]

[Redacted text]

[Redacted text]

[Redacted text]

[Redacted text]

[Redacted text]

Производительность резки при мощности 3-20 кВт

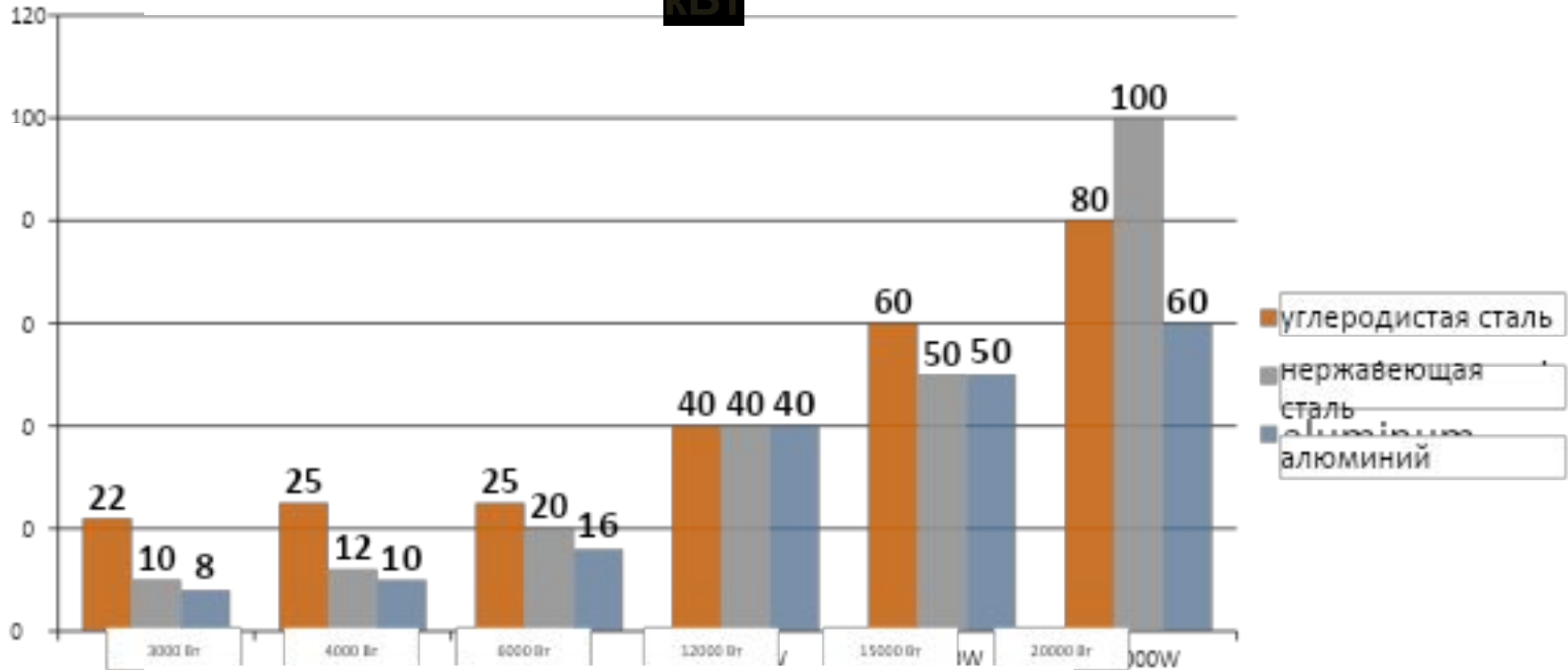

Модульная конструкция станка позволяет его загрузить в стандартные контейнеры.



Значительное снижение затрат на транспортировку



[Redacted text block]



[Redacted text block]



[Redacted text block]



Круглосуточная служба поддержки. Наши специалисты поддержки работают в две смены, чтобы обслуживать заказчиков в разных часовых поясах.



Обслуживание на месте установки. Мы всегда готовы выехать на ваш объект по запросу и предложить разумные цены.



Обучение на нашем заводе. Мы всегда рады провести обучение ваших сотрудников на нашем заводе.

