

Price request
Even Table

Additional information:

- VERY IMPORTANT – please try to reach the target price of €75 including packaging on pallets – EXW
- Tubes – find a standard dimension for the tubes, to minimize costs and state the size in the offer
- Alternative 1 – price like drawings
- Alternative 2 – Weld bottom plate with the tubes – 1 colli and the top screwed/assembled by the end customer
- Alternative 3 – fully assembled
- Price if we extend the bottom plate to 50 cm to get it more stable
- Surface needs to be smooth
- MOQ 50 – 100
- PLEASE FEEL FREE TO COME WITH ALTERNATIVE SUGGESTIONS



Title Date
EVEN Cafe tables 03/Apr/2019

Season Rev Units
SS19 B mm

Dimensions
 - ROUND 70: Ø:700 x H:740
 - SQUARE 65: W:650 x D:650 x H: 740

Materials
 - Electro-galvanized steel with outdoor powder coating
 - Stainless steel HEX screws
 - PTFE tape
 - Protective felt (black)
 - Plastic disc

Colours/Print
 SUITABLE FOR OUTDOOR:
 - Black: RAL 9005 Tiefschwarz, Gloss level 25%

Packaging
 One table is packed in 2 gift boxes:
 1 - Base Foot (Same for all design, Flat packed)
 1 - Table top (Round Ø70 or Square 65)

Logo
 - 45x25mm BRAS/BRASS PLATED LOGO PLATE, WITH 32mm PRINTED LOGO. GLUED ON THE BOTTOM SIDE OF EACH TABLE TOP.

Specific requirements
 - 6 countersunk screw M6x8
 - 8 countersunk screw M8x25
 - 1 corresponding Allen key for mounting
 - 1m of "Thread seal tape" (PTFE tape) to securised the screws.
 - 1 Black adhesive disc of protective felt (Ø420mm) for indoor uses
 - 1 perforated disc of plastic

ROUND 70 TABLE _ EXPLODED VIEW

Ø700 TOP (4mm THICK) WITH A PLATE (Ø320mm, 8mm THICK, WITH 6 THREADED HOLES) WELDED ON THE BOTTOM SIDE. MATERIAL: ELECTRO-GALVANIZED STEEL WITH OUTDOOR POWDER COATING.

WE PROBABLY NEED A PLASTIC/RUBBER/NYLON DISC IN BETWEEN BOTH PARTS TO IMPROVE THE SCREWED UNION. PLEASE ADVISE ON THIS.

CONNECTING PLATE (6mm THICK, WITH 10 CONTERSUNK HOLES: 6 FROM THE BOTTOM AND 4 FROM THE TOP)

2 X L PROFILES WELDED IN THE TUBE (EACH L PROFIL HAVE 2 THREADED HOLES)

2 X Ø85 TUBE (LENGTH 712mm, WALL THICKNESS 2mm) MATERIAL: ELECTRO-GALVANIZED STEEL WITH OUTDOOR POWDER COATING.

2 X L PROFILES WELDED IN THE TUBE (EACH L PROFIL HAVE 2 THREADED HOLES)

Ø420 BASE (10mm THICK WITH 4 CONTERSUNK HOLES) SCREWED TO THE TWO TUBES FEET FROM UNDERNEATH. MATERIAL: ELECTRO-GALVANIZED STEEL WITH OUTDOOR POWDER COATING.

PLEASE INCLUDE AN ADHESIVE DISC (Ø420mm) OF FELT (BLACK) TO PROTECT THE FLOOR IN CASE OF

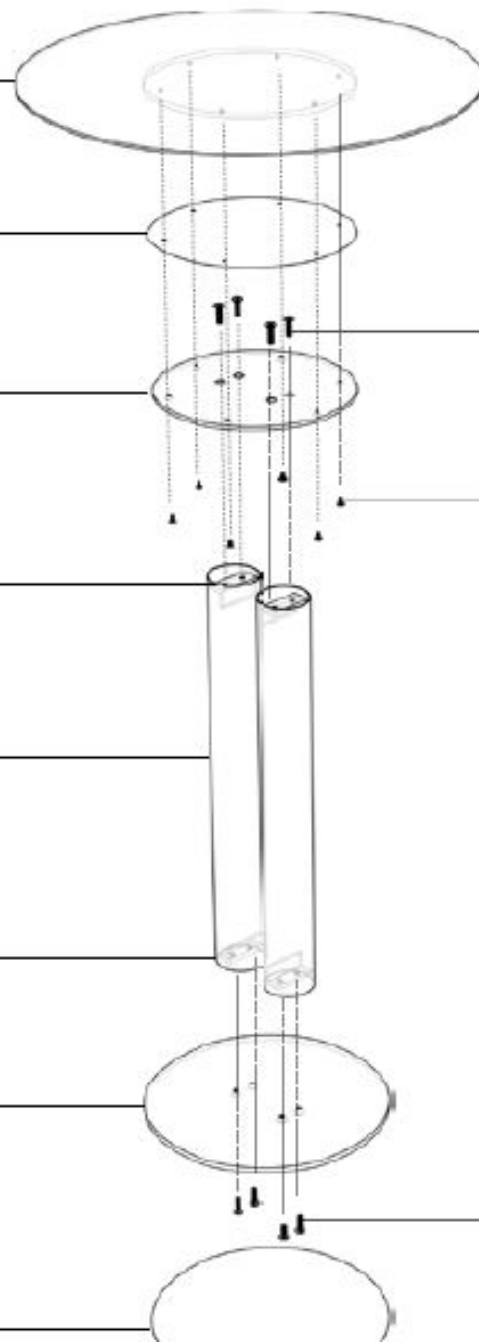

PLEASE NOTE:

IF YOU HAVE ANY BETTER SUGGESTIONS FOR THE CONSTRUCTION AND ASSEMBLY, WE WILL BE HAPPY TO HEAR ABOUT THEM. BUT PLEASE NOTE IT IS IMPORTANT FOR US THAT THE TABLE TOP KEEPS A FLAT, THIN EDGE. THANKS.

6 X COUNTERSUNK SCREWS ISO_10642_M6X8:

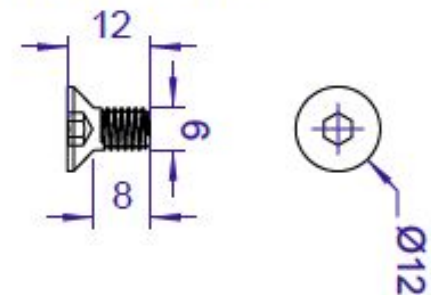

8 X COUNTERSUNK SCREWS ISO_10642_M8X25:

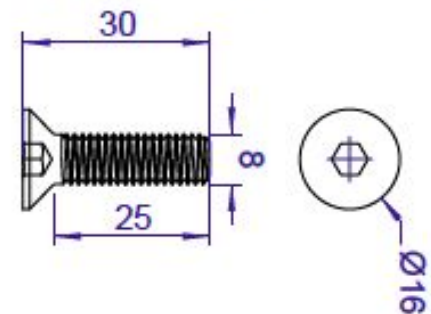

ROUND 70 CAFE TABLE _ GENERAL MEASUREMENTS

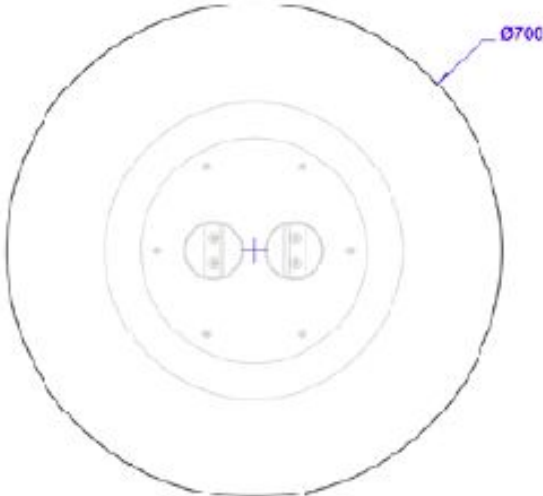

TOP VIEW



PERSPECTIVE

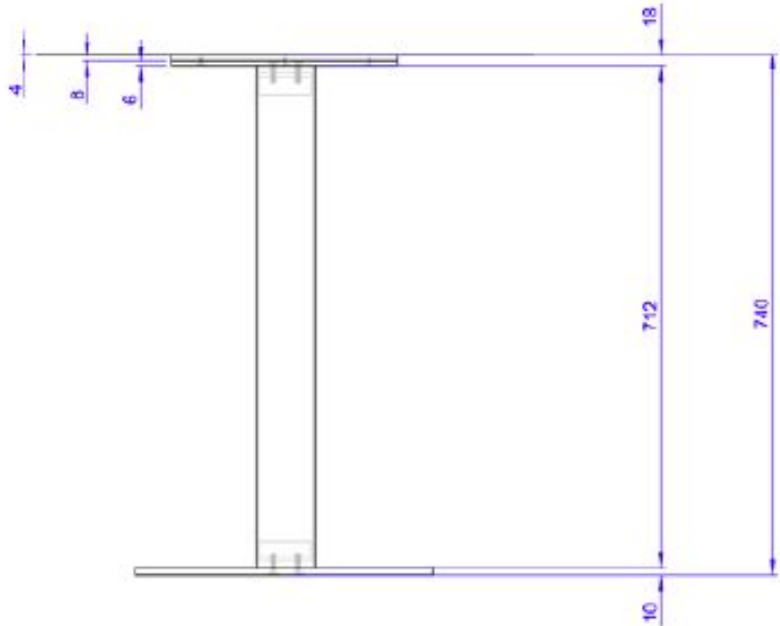
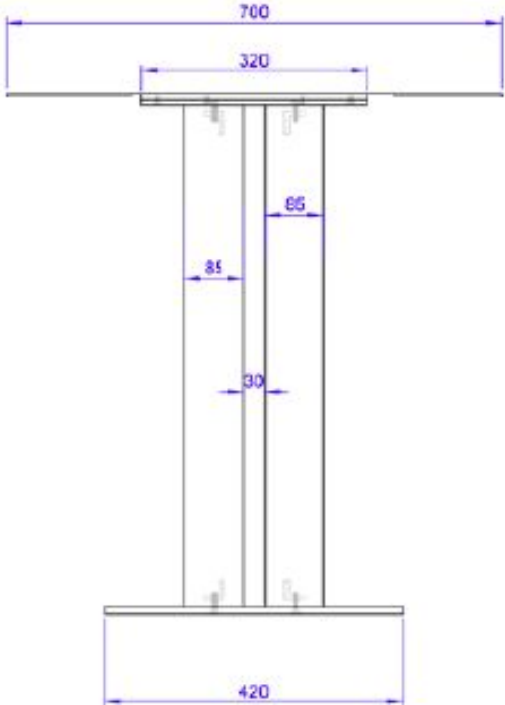

SQUARE 65 CAFE TABLE _ GENERAL MEASUREMENTS

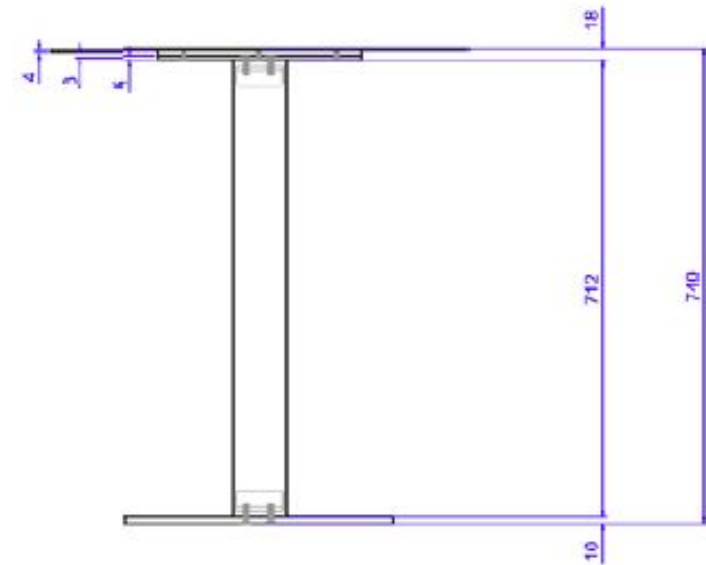
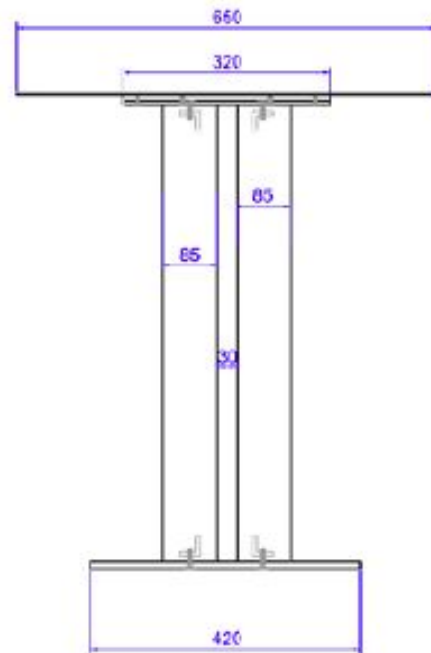
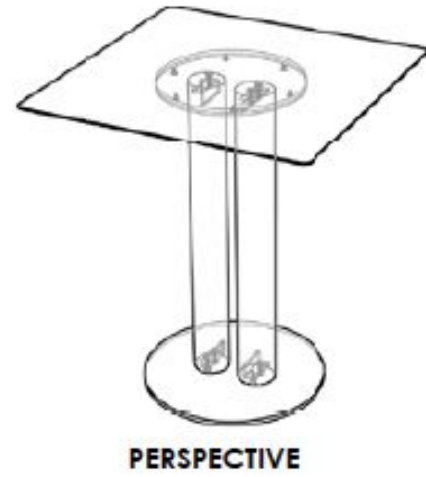
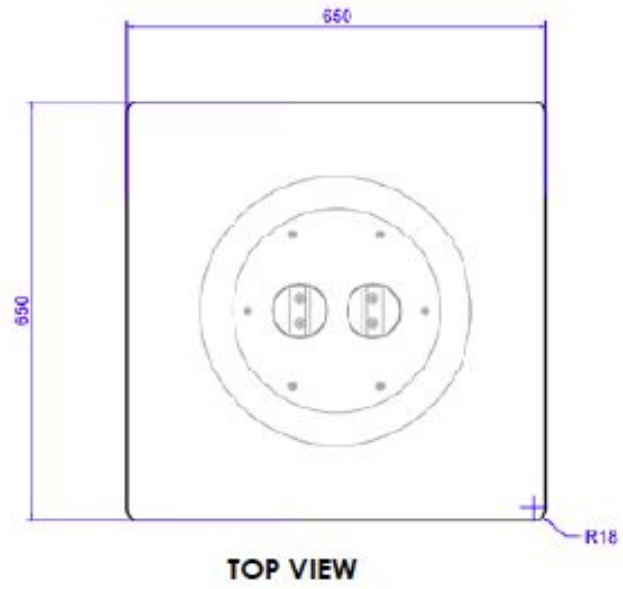

**TABLE TOP "ROUND 70" _ ELECTRO-GALVANISED STEEL
(PACKED IN "TABLE TOP GIFT BOX")**

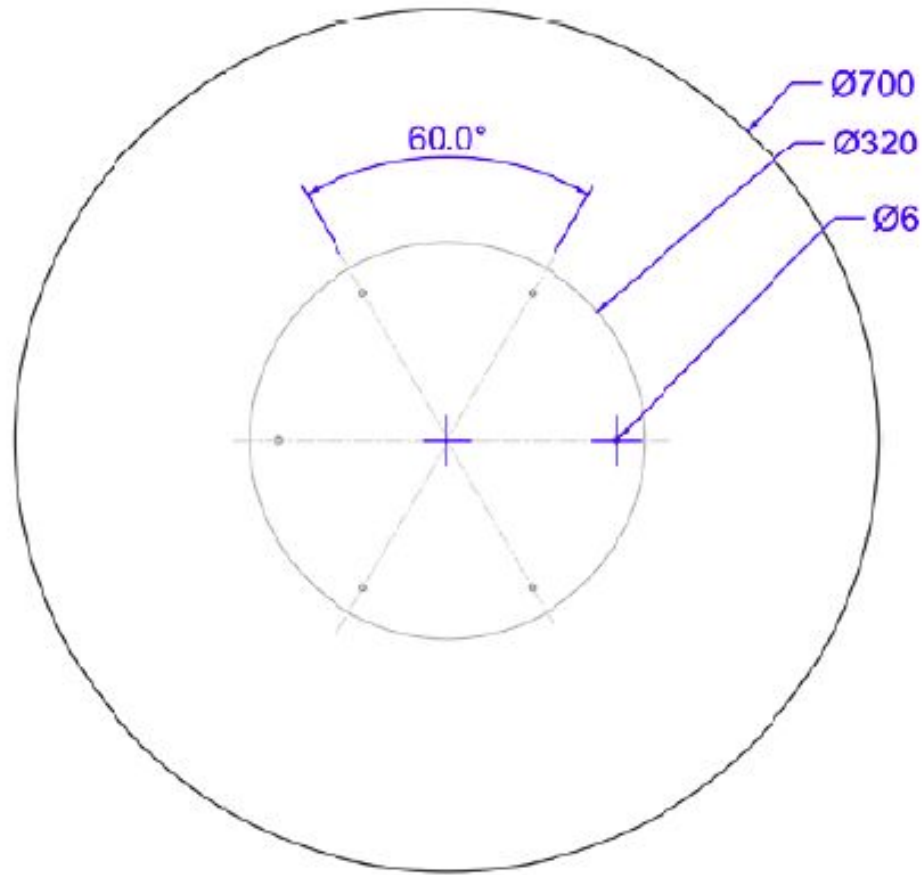

TOP VIEW

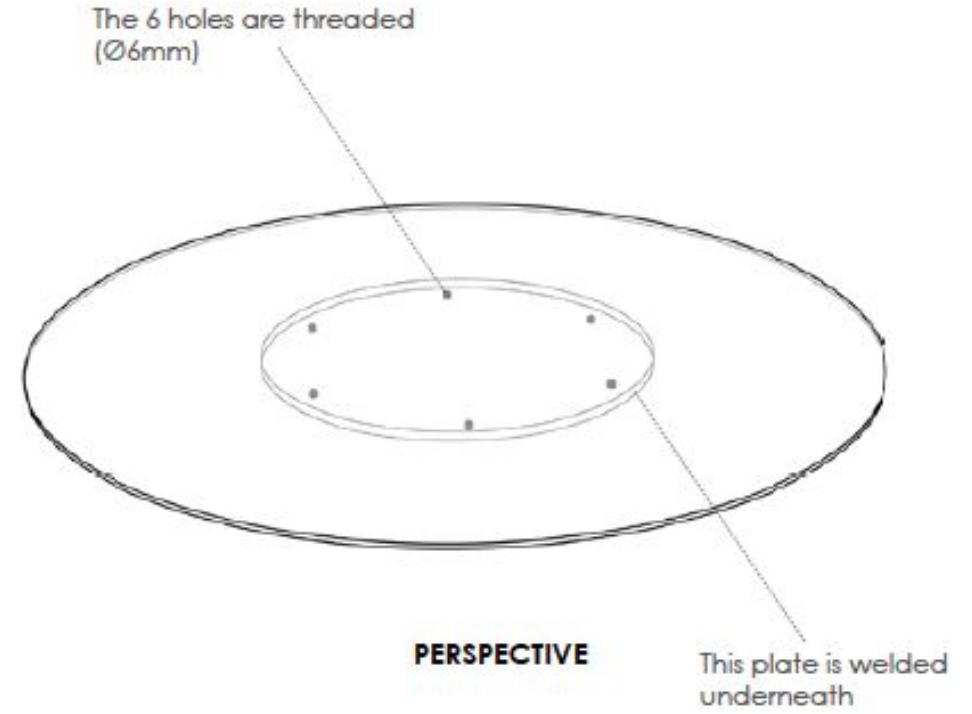

PERSPECTIVE

This plate is welded underneath



FRONT VIEW

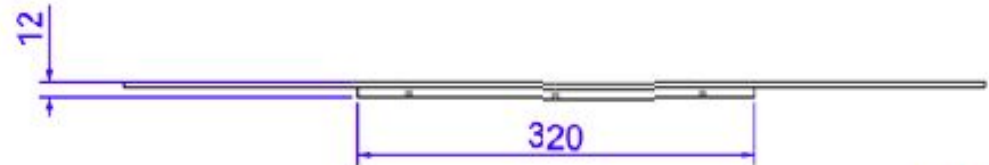

SIDE VIEW

**TABLE TOP "SQUARE 65" _ ELECTRO-GALVANISED STEEL
(PACKED IN "TABLE TOP GIFT BOX")**

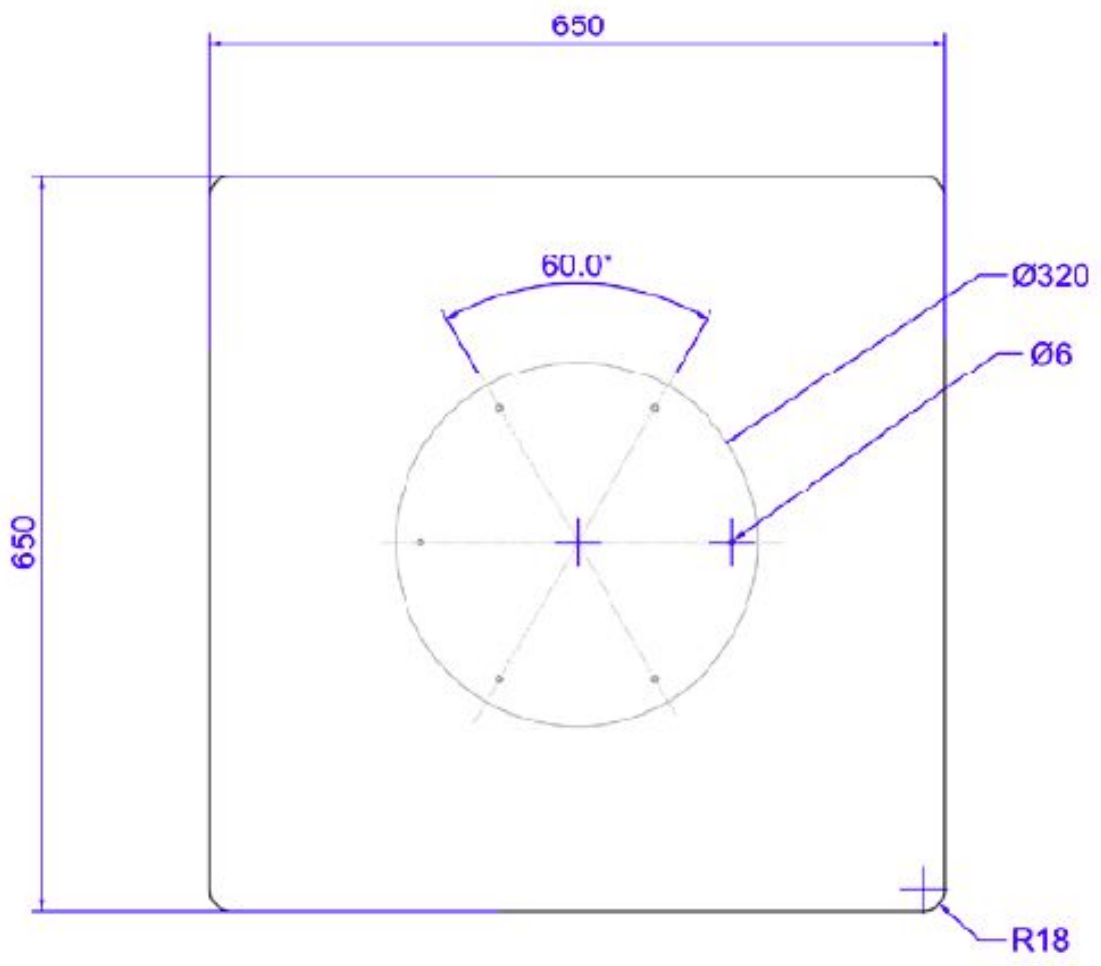

TOP VIEW

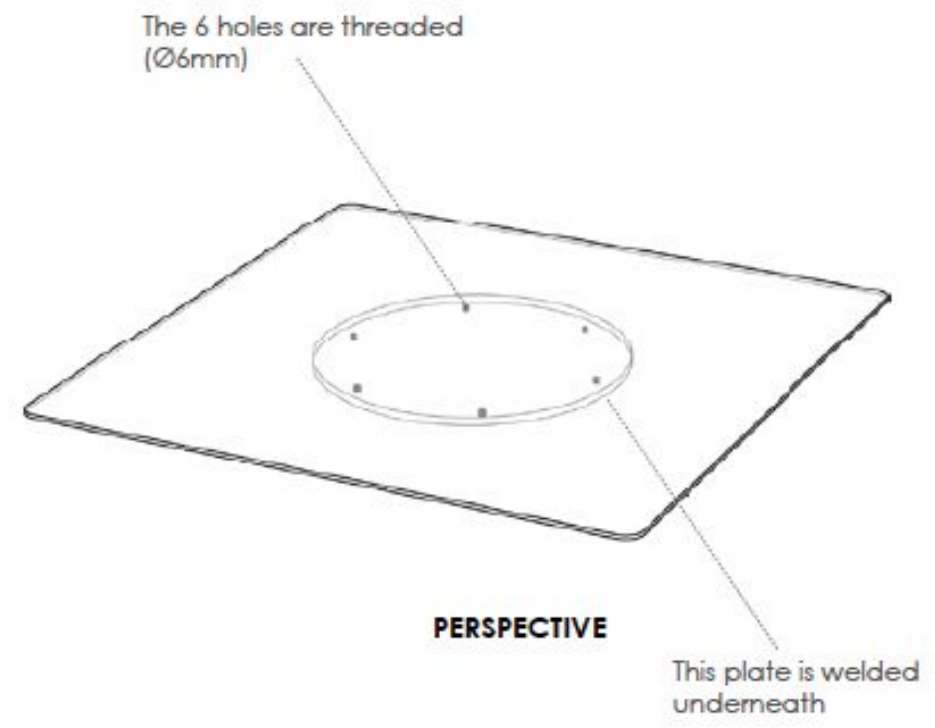

PERSPECTIVE



FRONT VIEW

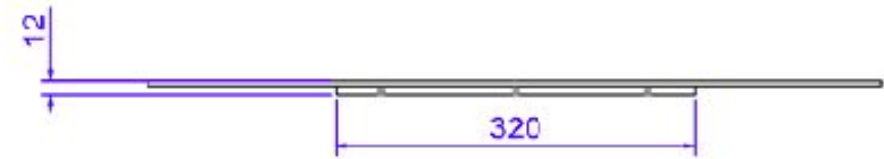

SIDE VIEW

**CONNECTING PLATE Ø320 _ ELECTRO-GALVANISED STEEL
(PACKED IN "FOOT GIFT BOX")**

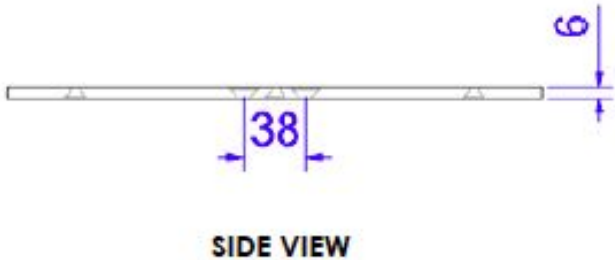
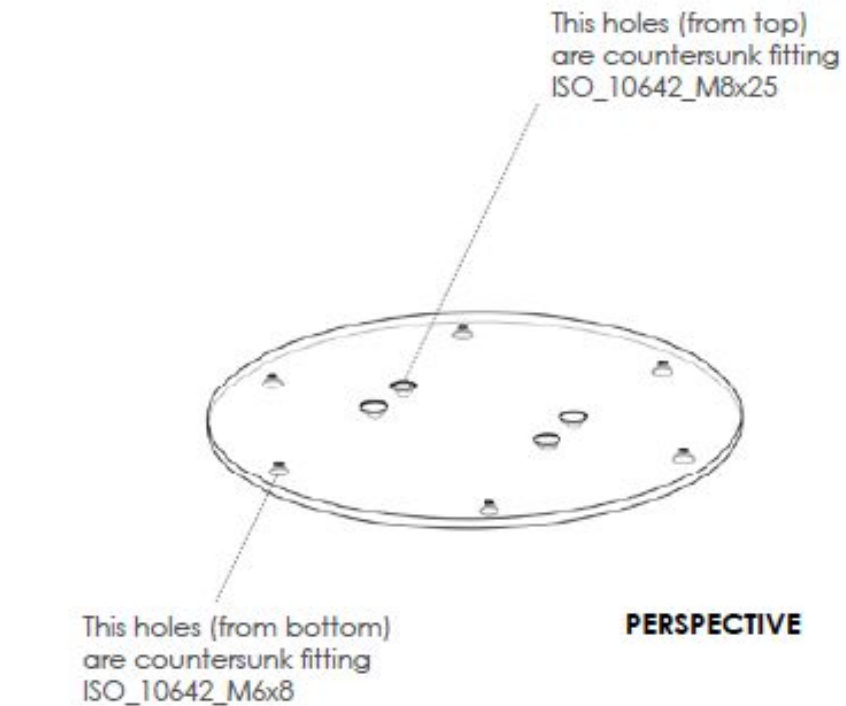
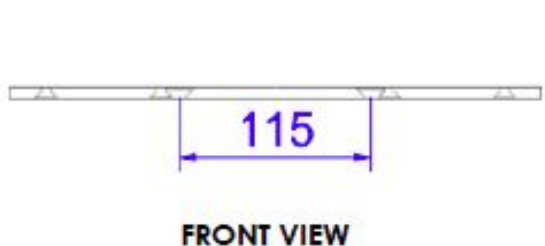
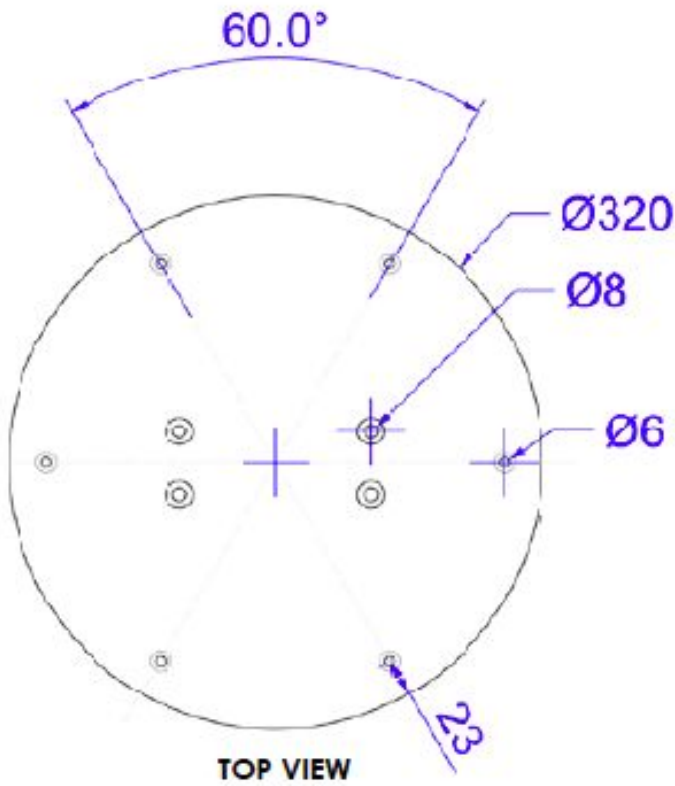

**FOOT TUBE (X2)_ ELECTRO-GALVANISED
(PACKED IN "FOOT GIFT BOX")**

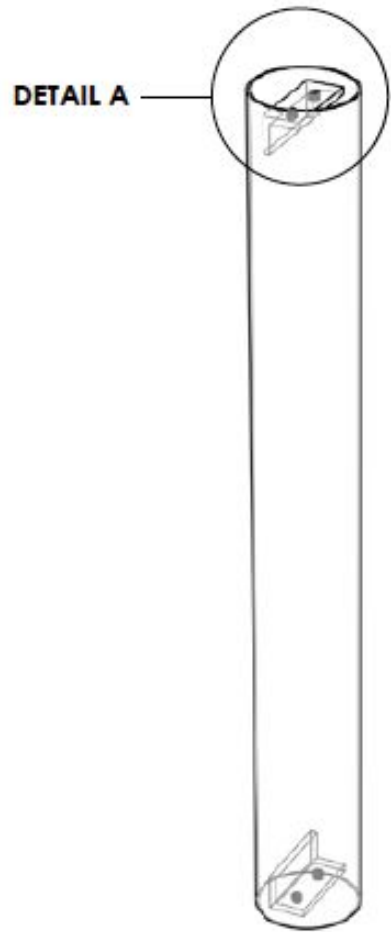

PERSPECTIVE

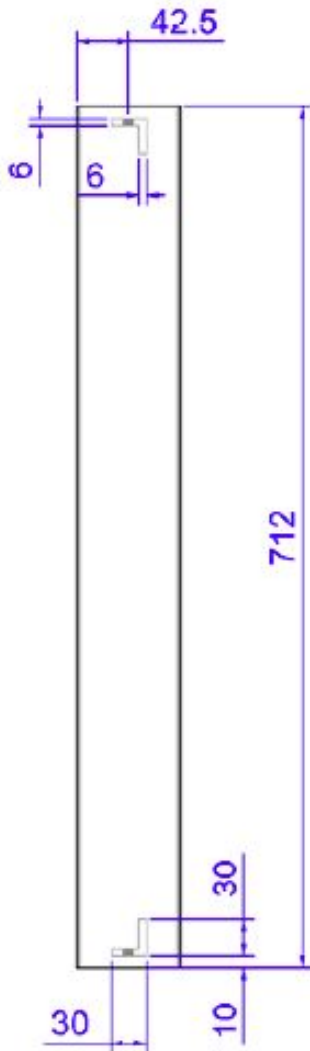

SIDE VIEW



FRONT VIEW

The L brackets are welded
10mm far from the edges

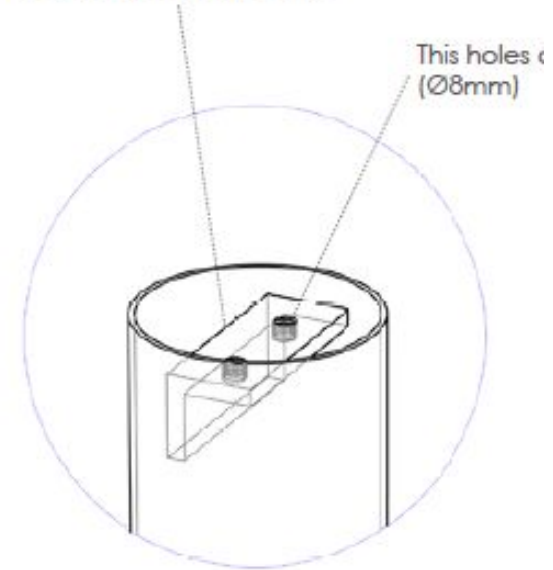

DETAIL A

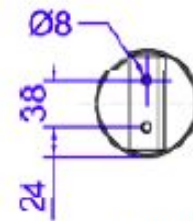

TOP VIEW

Important – tube must be standard dimension – so change if necessary for example 89 mm – to save costs

Wall thickness of the tube is 2mm but you can advise us on this.

**BASE Ø420 _ ELECTRO-GALVANISED STEEL
(PACKED IN "FOOT GIFT BOX")**

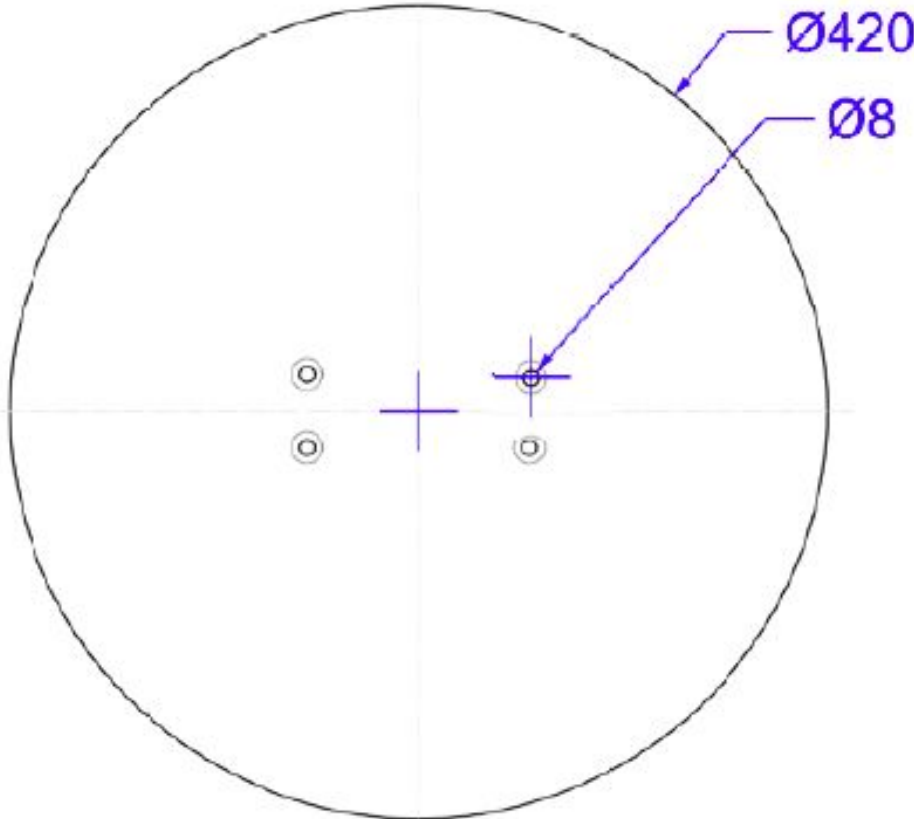

TOP VIEW

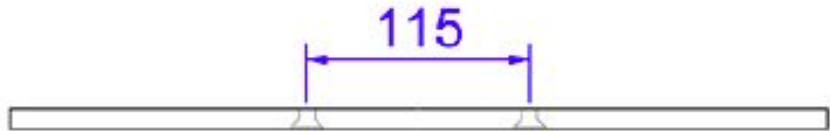

FRONT VIEW

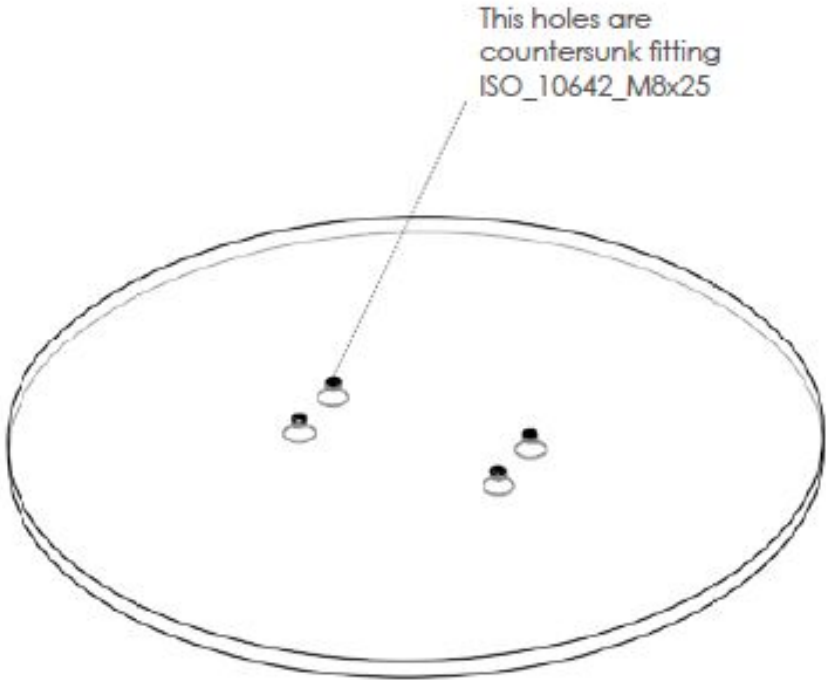

PERSPECTIVE

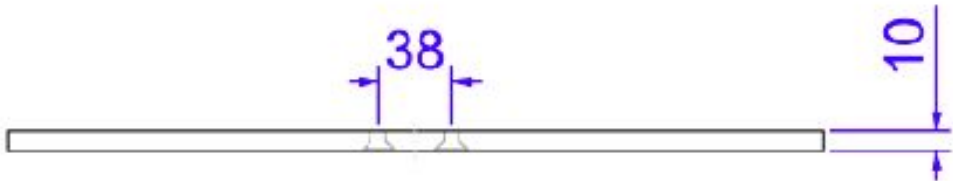

SIDE VIEW

INCLUDED WITH THE FOOT:

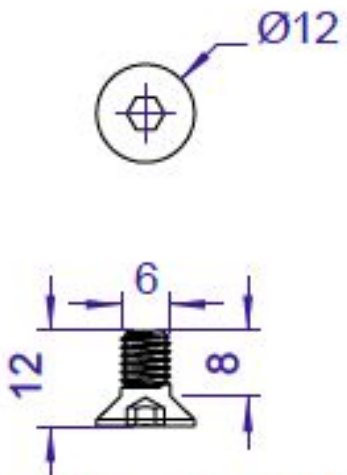

6 X COUNTERSUNK SCREWS
ISO_10642_M6X8
(HEX SCREWS, STAINLESS STEEL)

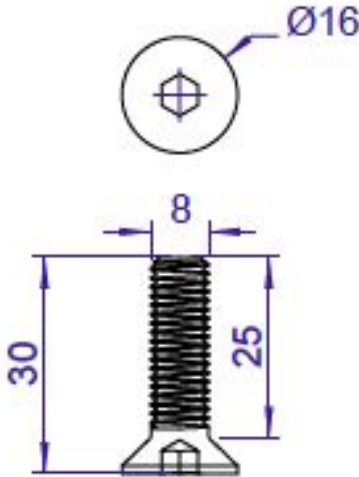

8 X COUNTERSUNK SCREWS
ISO_10642_M8X25
(HEX SCREWS, STAINLESS STEEL)



CORRESPONDING ALLEN KEY



1 METER OF PTFE TAPE



1 ADHESIVE DISC (Ø420mm)
OF PROTECTIVE FELT
(BLACK)

+ 1 PERFORATED PLASTIC DISC

