

System Description of BL ABS

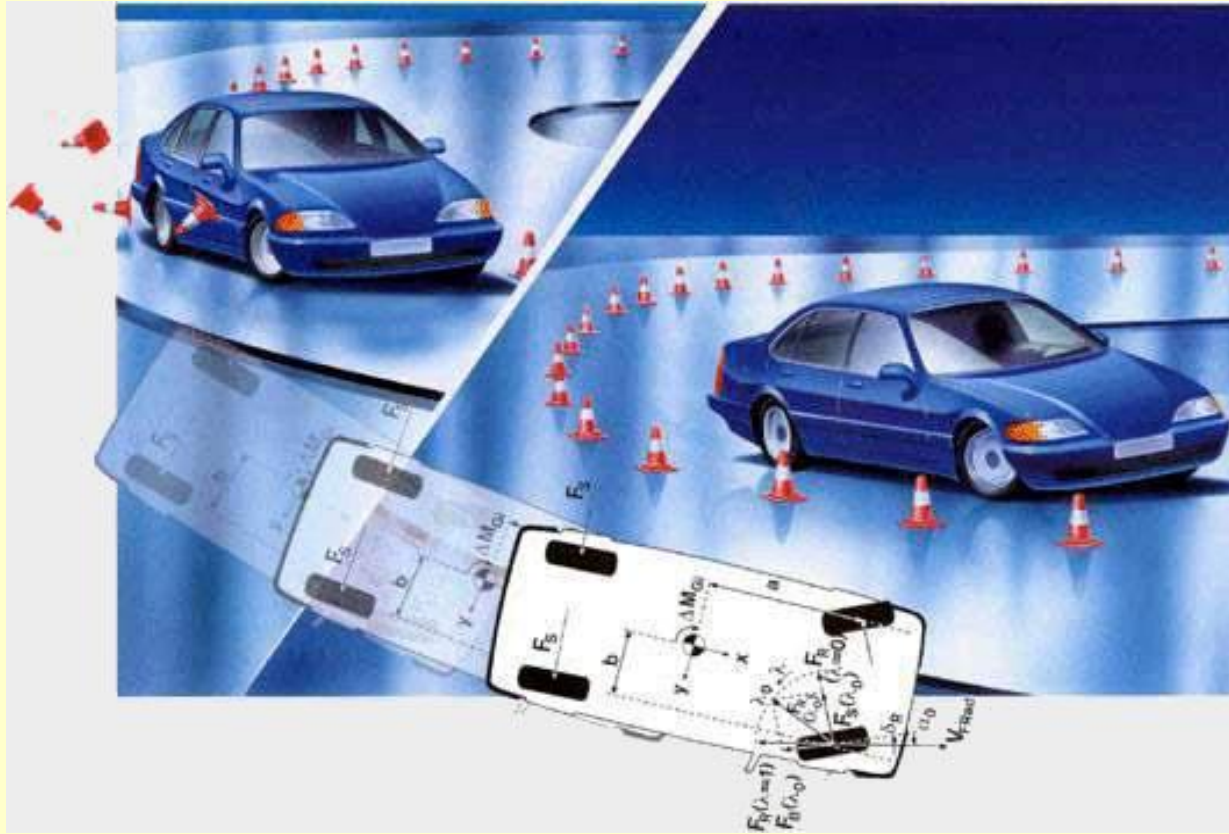

BL BOSCH 5.3 ABS

BL ABS Specification

▶ System

- BOSCH ABS 5.3
- 4Sensor 4Channel
- BRAKE Line : X Split
- ABS with EBD Control

▶ Hydro-Electronic Control Unit (HECU)

- Hydraulic Modulator : Size(84 X 118 X 170mm), Weight(2.6Kg)
- Motor : Large Size(180W)
- Solenoid Valve : Sol-Sol Type(Inlet/Outlet)
- ECU : Attached ECU

▶ Wheel Speed Sensor



- Inductive Sensor(Passive Type)
- Minimum P-P voltage : 120mV (2.75KPH)

▶ Acceleration Sensor

- Offset Voltage : 2.5V
- Operating voltage : 4.5V ~ 5.5V

BL BOSCH 5.3 ABS

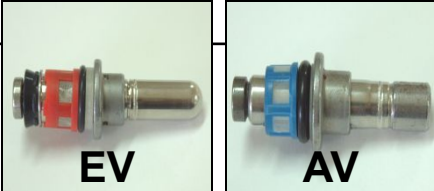
BL ABS Specification

ECU	Operating volt.	8 ~ 16V	
	Operating Temp.	-40°C ~ 120 °C	
	Reverse volt.	-13.5V	
HECU (HU+ECU)	Weight	2.7 Kg	
	Pump capacity	4.8 cc/sec	
	Power consum.	230W	
Solenoid Valve	Resistance	Inlet Valve (EV) : $8.54\Omega \pm 0.5\Omega$	
		Outlet Valve (AV) : $4.29\Omega \pm 0.25\Omega$	
Return Pump Motor	Operating current	45A or less ($10.5V \pm 0.5V$, $23\text{ °C} \pm 5\text{ °C}$)	
	Max. current	145A or less ($16V \pm 0.1V$, $23\text{ °C} \pm 5\text{ °C}$)	
Wheel Speed Sensor	Coil resistance	$1600\Omega \pm 10\%$	- Air Gap Front : 0.3~1.2 mm Rear : 0.3~1.2 mm
	Insulation resist.	1M Ω	
	Tone wheel	48 EA	

BL BOSCH 5.3 ABS

HECU

►ABS5.3 model

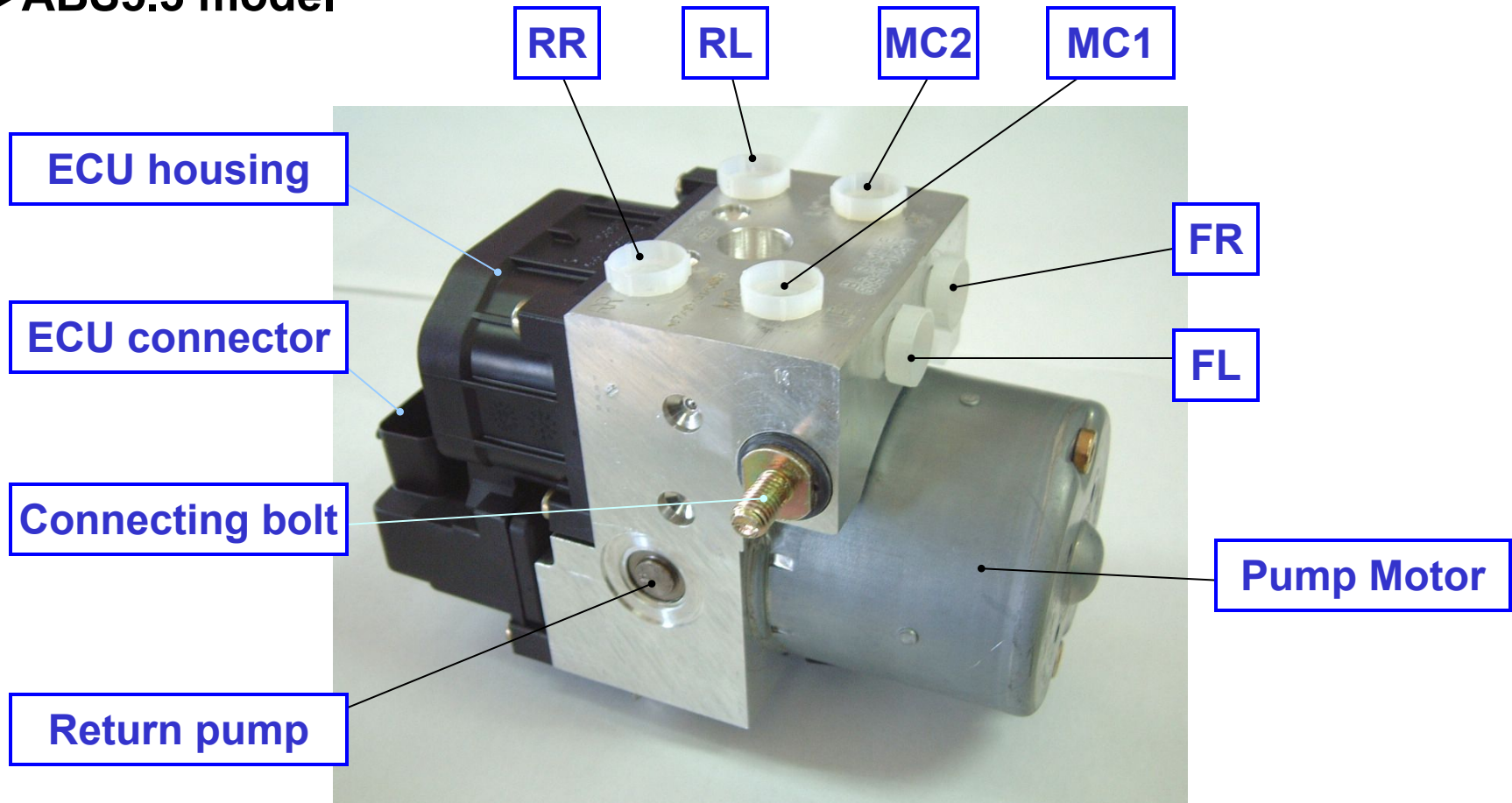

BL BOSCH 5.3 ABS

HECU Location



BL BOSCH 5.3 ABS

HECU Appearance

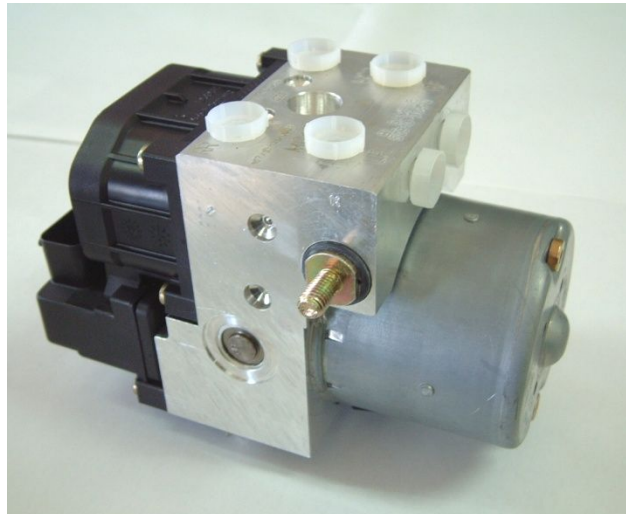

▶ABS 5.3

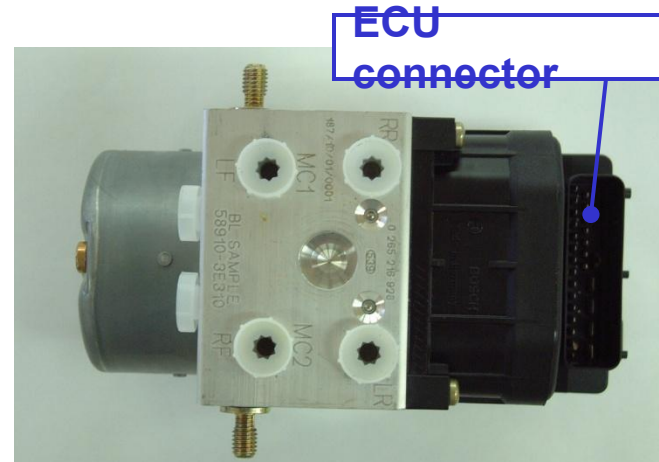

▶Top view

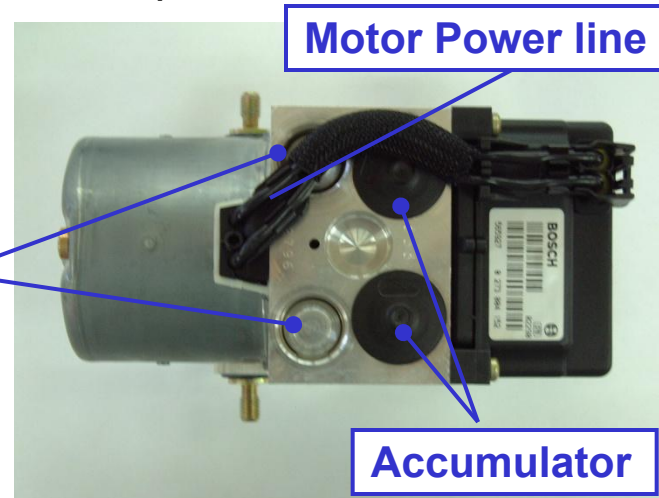

▶Bottom view

BL BOSCH 5.3 ABS

ABSCM Housing

- ▶ Never Disassemble HECU

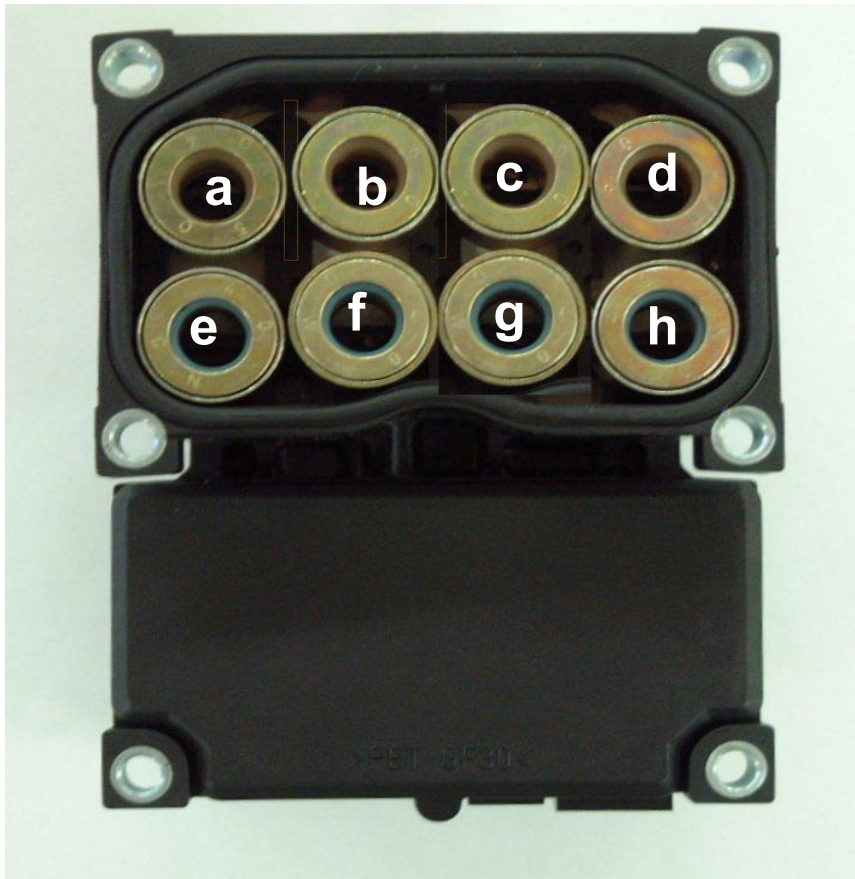

- ▶ valve seat coil assembly

a	Inlet valve (RR)
b	Inlet valve (FL)
c	Inlet valve (FR)
d	Inlet valve (RL)
e	Outlet valve (RR)
f	Outlet valve (FL)
g	Outlet valve (FR)
h	Outlet valve (RL)

BL BOSCH 5.3 ABS

ABSCM Input & Output

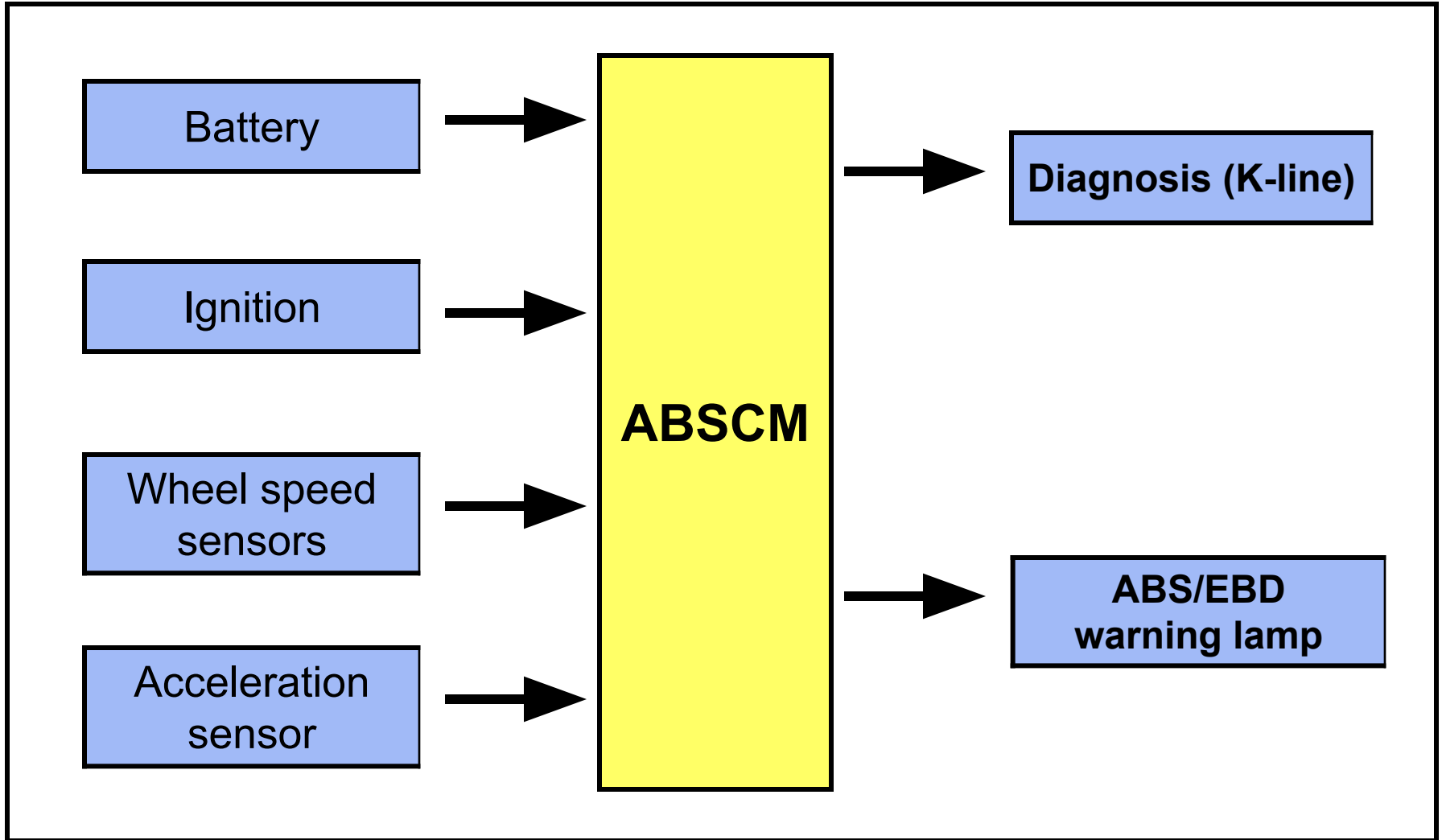

BL BOSCH 5.3 ABS

Valve/Pump motor relay fuse



VALVE, MOTOR RELAY FUSE

BL BOSCH 5.3 ABS

Acceleration Sensor

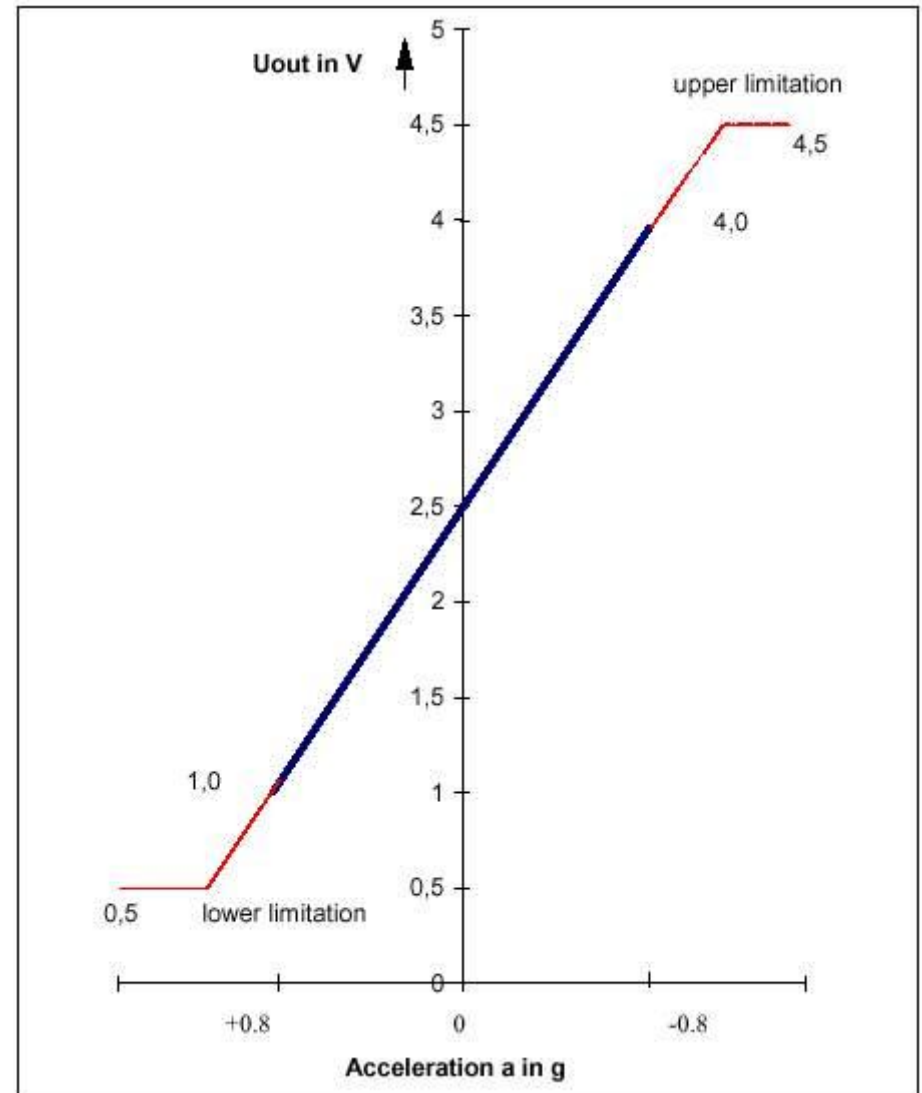

BL BOSCH 5.3 ABS

Diagonal Circuit of BL ABS5.3

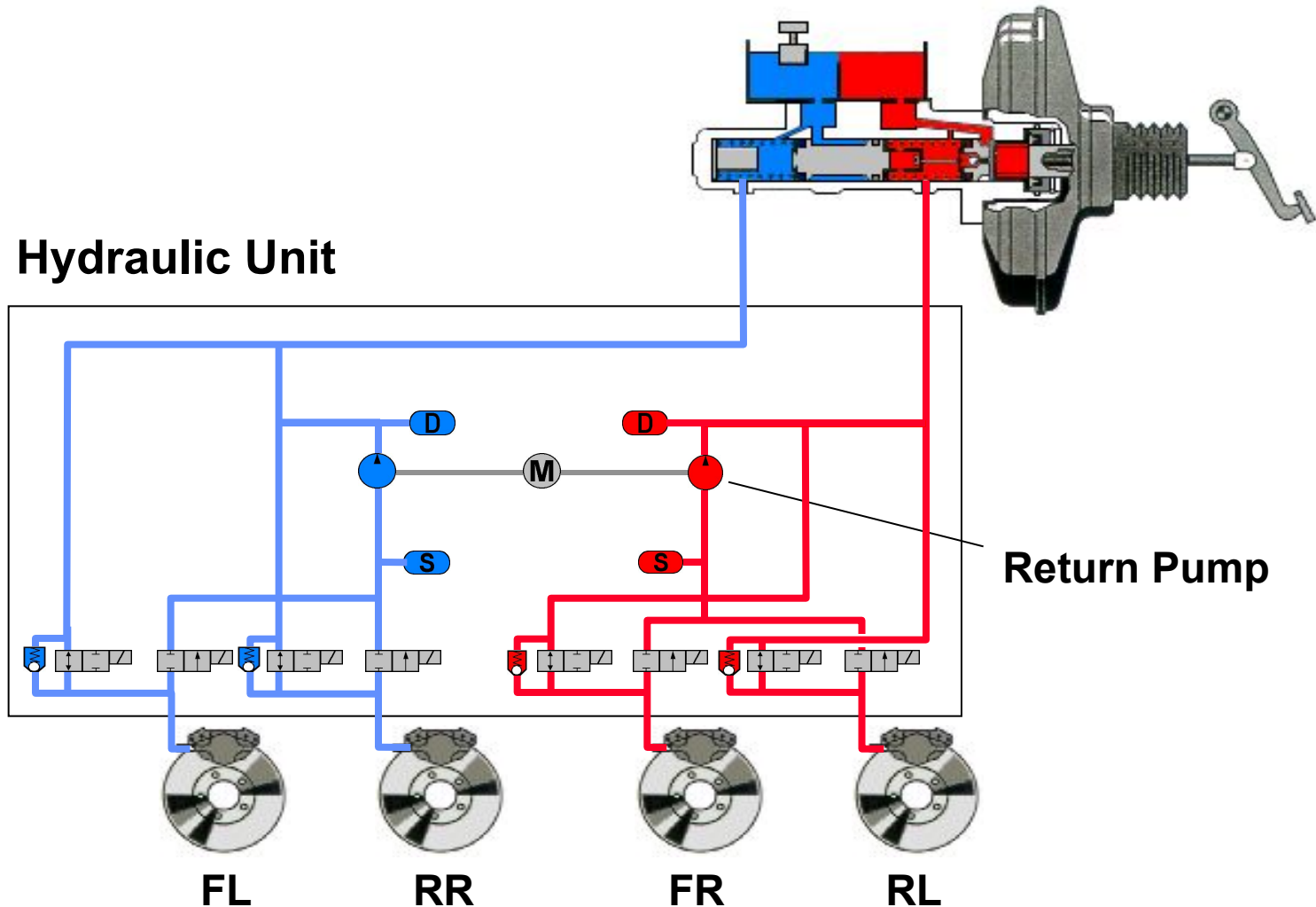

BL BOSCH 5.3 ABS

Hydraulic Unit (Modulator)

▣ Normal Condition

Solenoid Valve	LFEV/RFEV/LREV/RREV	NO
	LFAV/RFAV/LRAV/RAV	NC
Pump Motor	OFF	

LF : LEFT WHEEL OF FRONT
RF : RIGHTWHEEL OF FRONT

LR : LEFT WHEEL OF REAR
RR : RIGHT WHEEL OF REAR

EV : INLET VALVE
AV : OUTLET VALVE

NO : NORMAL OPEN
NC : NORMAL CLOSE

BL BOSCH 5.3 ABS

Normal condition

- Brake pressure from the M/C directly delivers to wheel cylinders
- ABS/SCM does not operate
- Normal braking without the operation of NO, NC valves

Solenoid valve	EV	OPEN (OFF)
	AV	CLOSE (OFF)
PUMP MOTOR	OFF	

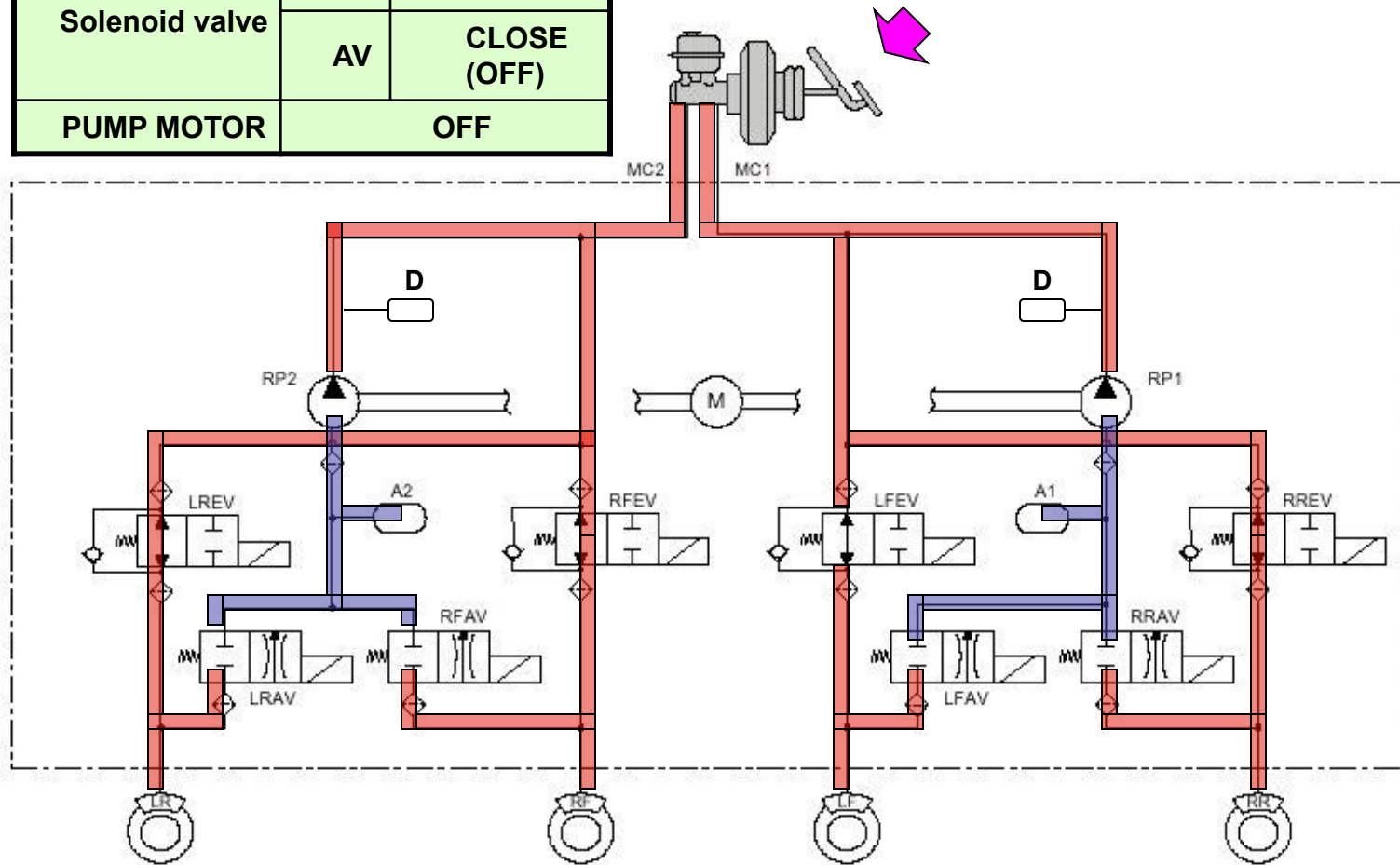

BL BOSCH 5.3 ABS

Pressure Dump

- Stiff braking pressure → reduced friction, Wheel Lock-up tendency
- ABS/CM reduces the brake pressure of corresponding wheels
- Pump Motor dumps brake pressure to the M/C side

Solenoid valve	EV	CLOSE (ON)
	AV	OPEN (ON)
PUMP MOTOR		ON

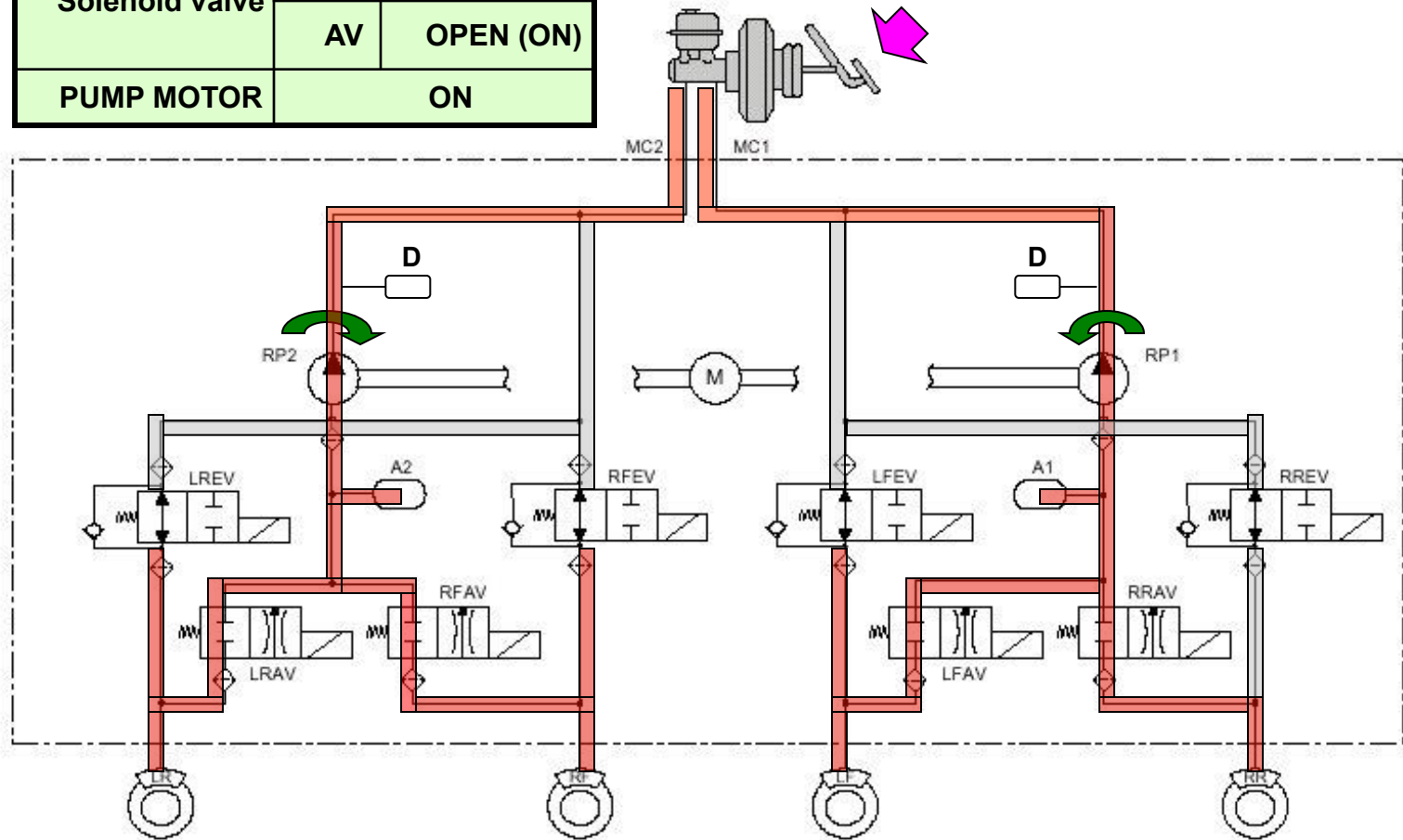

BL BOSCH 5.3 ABS

- Pressure Hold**
- To make a proper decision of wheel rotation while pressure dump or pressure increase mode
 - To hold the brake pressure of wheel cylinder

Solenoid valve	EV	CLOSE (ON)
	AV	CLOSE (OFF)
PUMP MOTOR	ON	

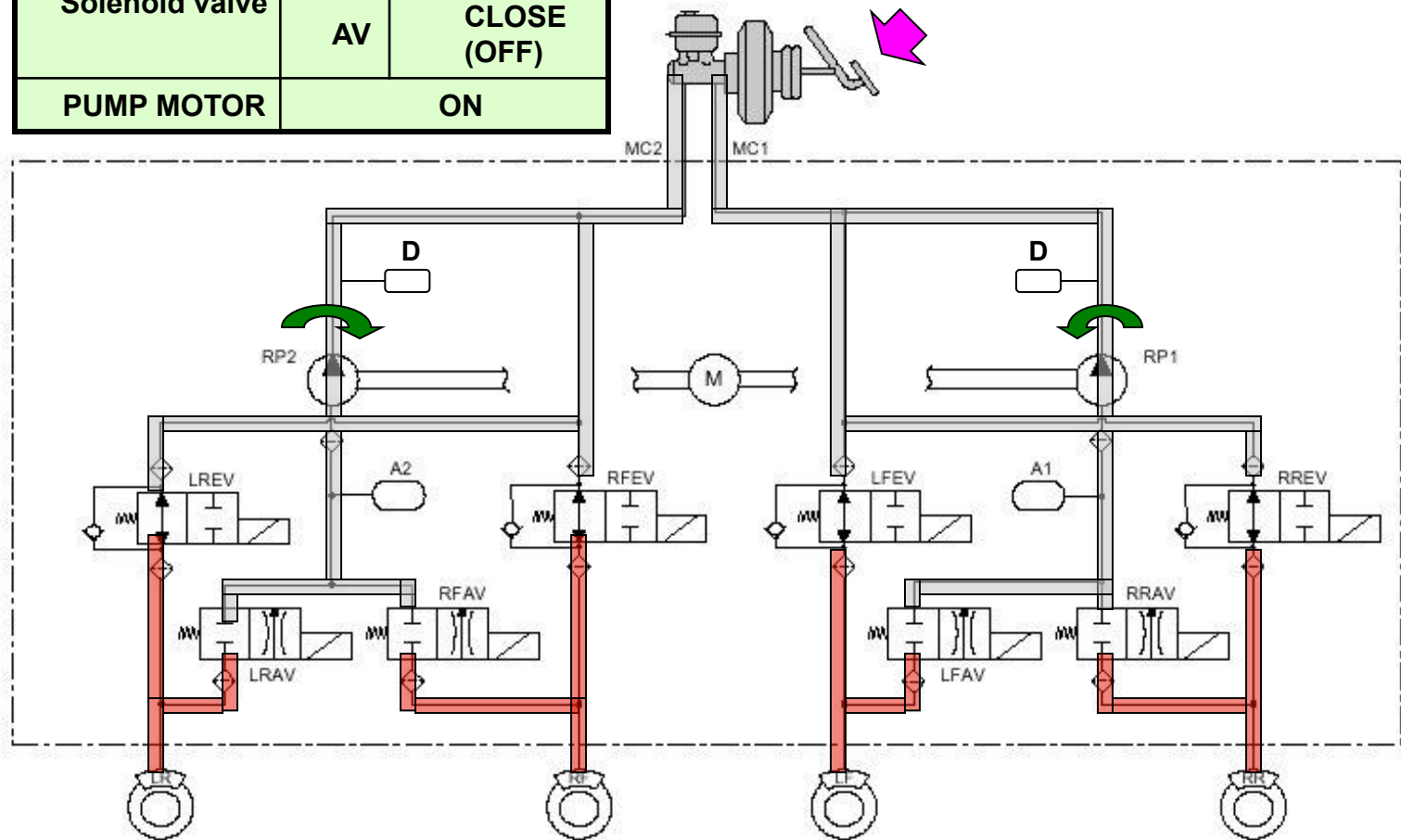

BL BOSCH 5.3 ABS

Pressure Increase

- If a frictional force between tire and road surface increases, ABSCM increases brake pressure again

Solenoid valve	EV	OPEN (OFF)
	AV	CLOSE (OFF)
PUMP MOTOR	ON	

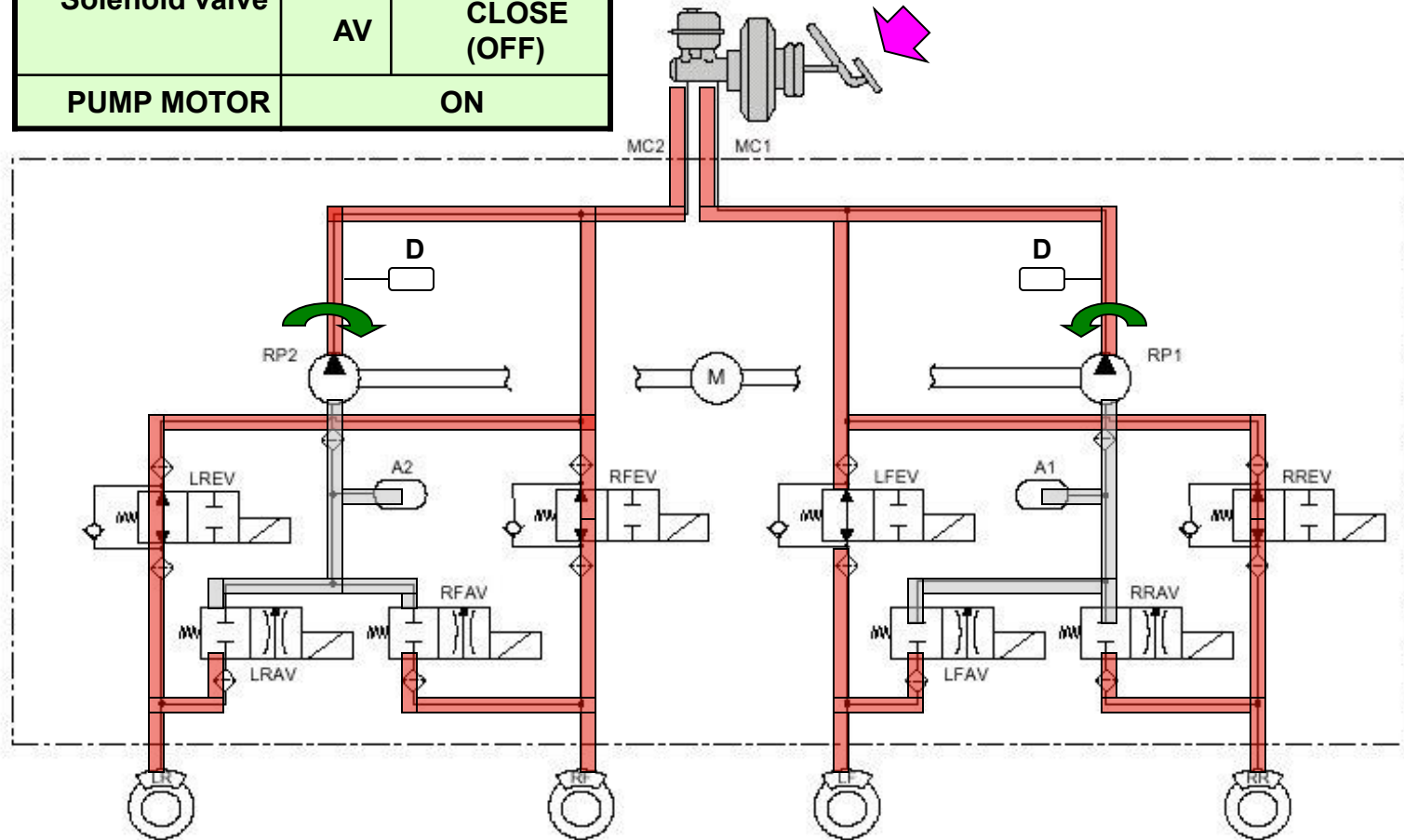

EBD(Electronic Brake-force Distribution)

1. EBD Modulation

2. Advantage of EBD

3. EBD Failure Matrix(Rev. 4)

BL BOSCH 5.3 ABS

EBD Modulation

* EBD control example

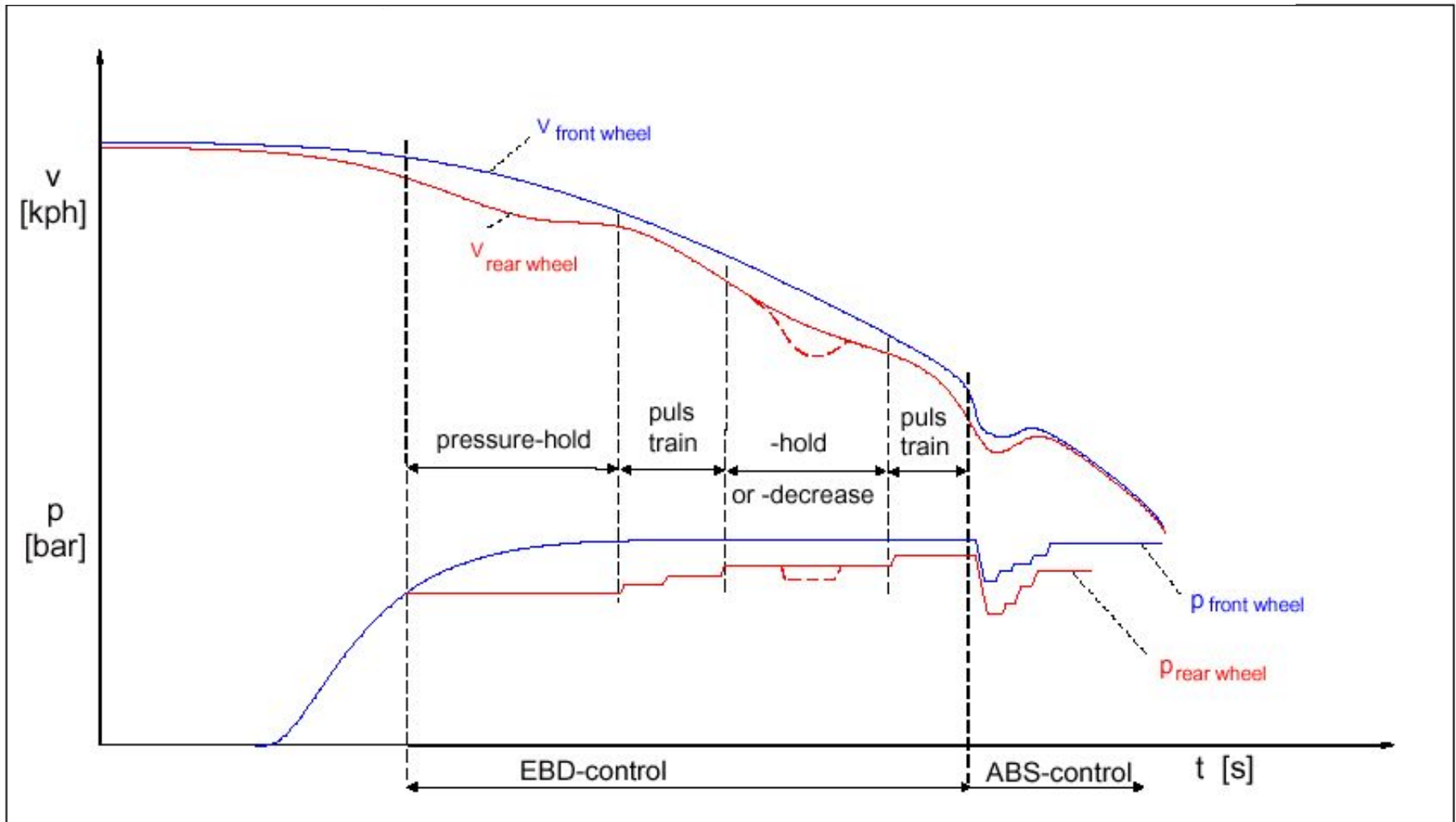

BL BOSCH 5.3 ABS

EBD Curve

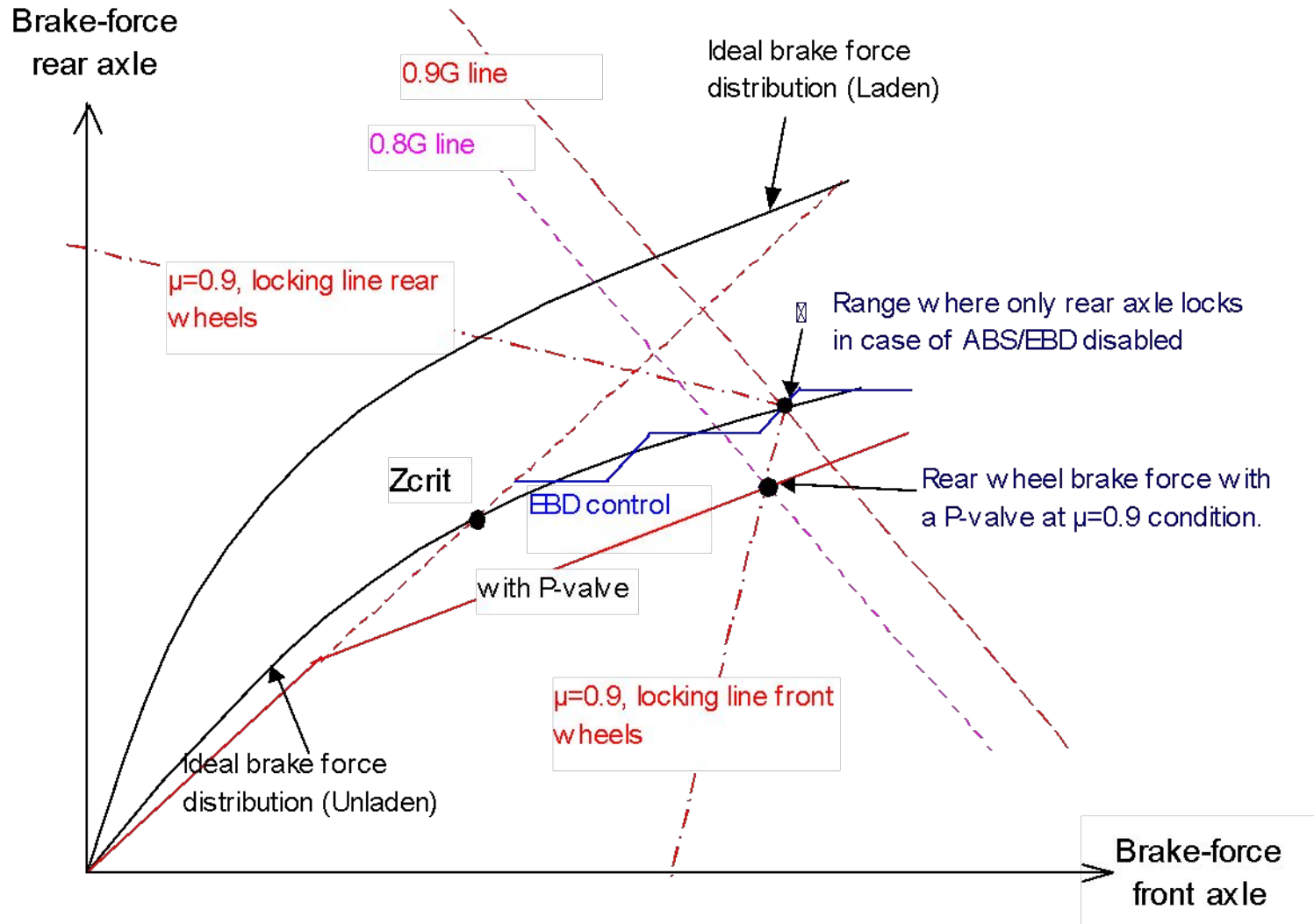

Advantages of EBD

- (load sensitive) proportioning valve may be omitted
- increase of rear axle contribution to brake-force
- Approach to ideal brake-force distribution
(straight-ahead and bend driving)
- Adaptive to different loading conditions
- Constant brake-force distribution during vehicle live time
- Monitoring of EBD-function
- Minimal extension of ABS hardware required

BL BOSCH 5.3 ABS

Failure Matrix of EBD Rev.4

- ABS disabled, EBD enabled(Keep Alive Function)
- ABS and EBD disabled
- ABS and EBD enabled
- X not possible

		low voltage 9,4V > Uz > 6,9V	low voltage <6,9 V <- reversibl *1)	over-voltage >17,4 V	WSS-failure ohm	WSS-failure non-ohm (FDFP)	WSS-failure high-frequency	WSS-failure low-frequency (FFZ)	2 WSS-failures	BLS-Failure	BLS	PM	MR	VR	G-Switch
Power-supply	reversible -> low voltage 9,4V > Uz >	X	X	X											
WSS	wheel speed sensor ohm														
	non-ohm (FDFP)														
	2 WSS-failures														
	reversible -> high-frequency														
BLS	brake light switch									X					
PM	pump motor failure											X	X		
MR	motor relay failure											X	X		
VR	ventil relay sticking													X	X
G-Switch	sensor failure														X

first failure that always leads to keep alive function

second failure

Power-supply *1) thresholds hard-ware depended

WSS WSS-failure high-frequency <- reversible

WSS-failure low-frequency (FFZ)

BLS

PM

MR

VR

G-Switch

BL BOSCH 5.3 ABS

ABS & EBD Warning Lamp



EBD & Parking brake lamp

Illuminate for 3 seconds after IG key ON

ABS Warning Lamp

- ECU Failure
- Solenoid Valve Failure
- Parking Brake
- Lacking of Brake Oil
- Short ' G Bar failure

- Wheels sensor failure (Open or short)
- Pump Motor & Valve Fuse Open
- Low / High Voltage
- While diagnosis
- Short ' G Bar failure

BL BOSCH 5.3 ABS

Function of ABS & EBD Warning Lamp Relay

1. ABS & EBD Warning Lamp(Passive Type)

2. ABS External Wiring Diagram

3. ABSCM Connector

4. Pin Assignment

BL BOSCH 5.3 ABS

Wiring Diagram

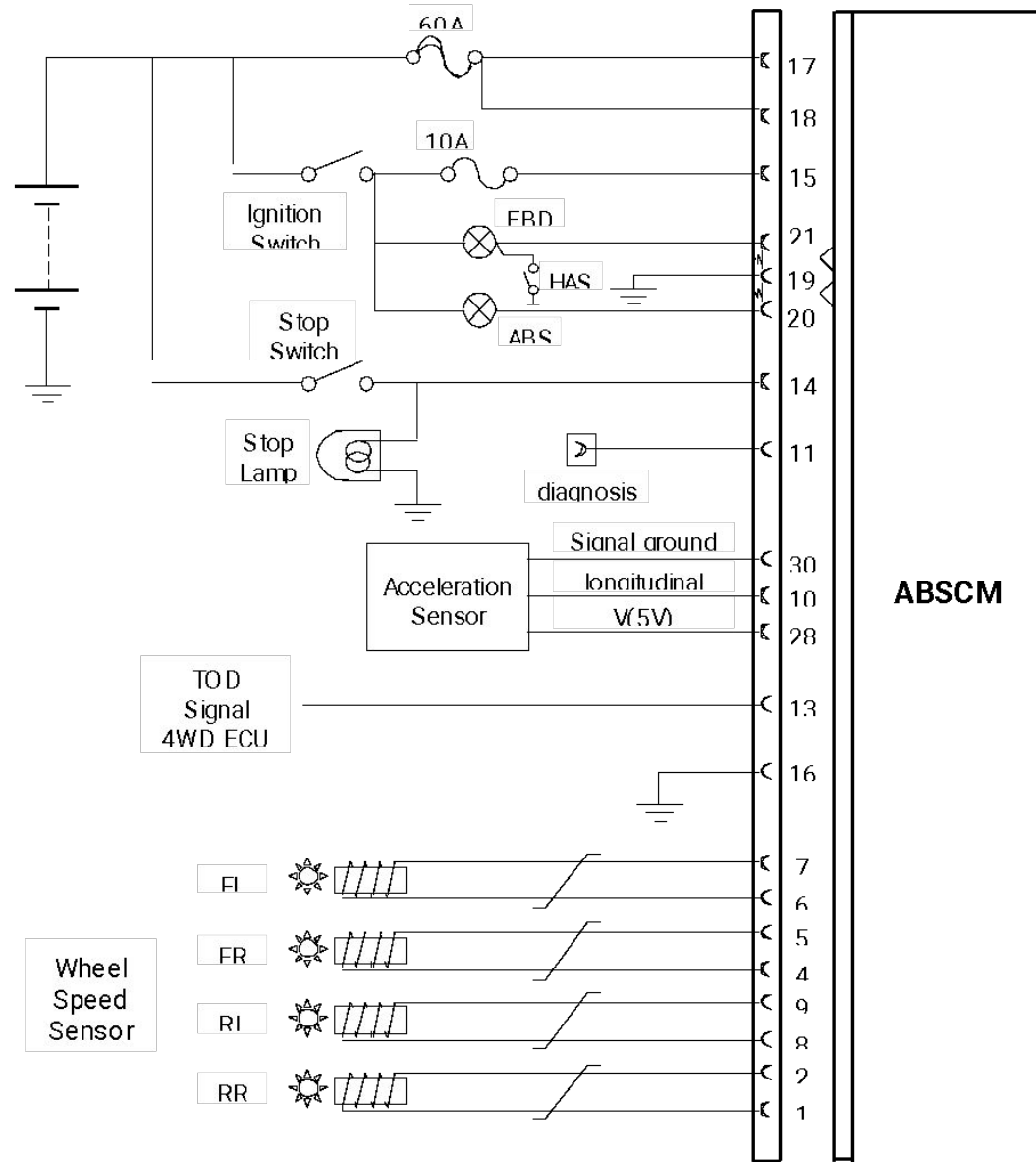

BL BOSCH 5.3 ABS

ABSCM Connector

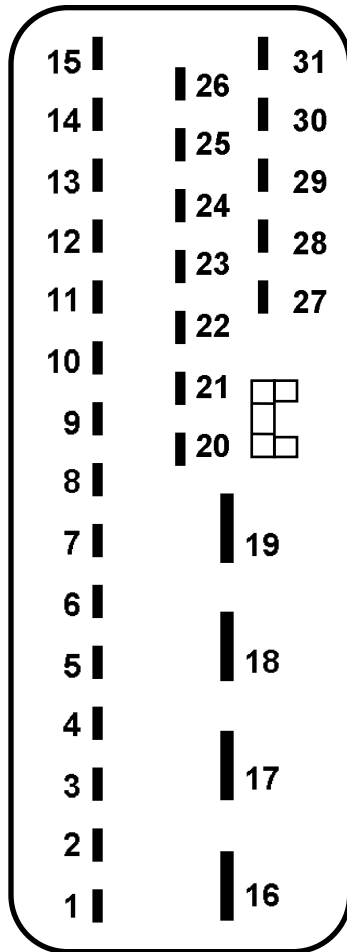

15	UZ
14	BLS
13	TOD
12	---
11	DIAGK
10	AL
9	DFRL
8	MDFRL
7	DFFL
6	MDFFL
5	DFFR
4	MDFFR
3	---
2	DFRR
1	MDFRR

26	---
25	---
24	---
23	---
22	---
21	EBVSILA
20	ABSSILA
19	SGND
18	UB-VR
17	UB-MR
16	MGND

31	---
30	AGND
29	---
28	UST
27	---



BL BOSCH 5.3 ABS

Pin Assignment

1	WSS - RR(-)
2	WSS - RR(+)
3	
4	WSS - FR(-)
5	WSS - FR(+)
6	WSS - FL(-)
7	WSS - FL(+)
8	WSS - RL(-)
9	WSS - RL(+)
10	AL sensor output
11	Diagnosis - K line
12	
13	TOD

14	Brake lamp switch
15	ECU power (IG)
16	Ground - motor
17	Power - relay
18	Power - relay
19	Ground - ECU
20	ABS warning lamp
21	EBD warning lamp
28	AL - input voltage
30	AL - ground

BL BOSCH 5.3 ABS

Troubleshooting

1. DTC list

2. System failure diagnosis

3. Air Bleeding

4. Hi-Scan Pro

BL BOSCH 5.3 ABS

Troubleshooting

DTC list

DTC	Description	W/L	Check point
C0800	High voltage (over 16V)	O	Battery voltage, Wire, Fuse
C0800	Low voltage (8V or less)	O	Battery voltage, Wire, Fuse
C0035	WSS FL - Continuity	O	WSS, Conn., Wire Harness
C0035	WSS FL - Plausibility	O	Wire check, Short, Air gap, Tooth
C0040	WSS FR - Continuity	O	WSS, Conn., Wire Harness
C0040	WSS FR - Plausibility	O	Wire check, Short, Air gap, Tooth
C0045	WSS RL - Continuity	O	WSS, Conn., Wire Harness
C0045	WSS RL - Plausibility	O	Wire check, Short, Air gap, Tooth
C0050	WSS RR - Continuity	O	WSS, Conn., Wire Harness
C0050	WSS RR - Plausibility	O	Wire check, Short, Air gap, Tooth

BL BOSCH 5.3 ABS

Troubleshooting

DTC list

DTC	Description	W/L	Check point
C0930	Acceleration sensor	O	Plug Conn., Sensor failure, Wire open
C0060	Solenoid Valve - LF(AV)	O	Short, MV line open
C0065	Solenoid Valve - LF(EV)	O	Short, MV line open
C0070	Solenoid Valve - RF(AV)	O	Short, MV line open
C0075	Solenoid Valve - RF(EV)	O	Short, MV line open
C0080	Solenoid Valve - RL(AV)	O	Short, MV line open
C0085	Solenoid Valve - RL(EV)	O	Short, MV line open
C0090	Solenoid Valve - RR(AV)	O	Short, MV line open
C0095	Solenoid Valve - RR(EV)	O	Short, MV line open
C0110	Motor pump	O	Motor or Relay circuit failure
C0121	Valve Relay	O	Valve relay failure

BL BOSCH 5.3 ABS

Troubleshooting

DTC list

DTC	Description	W/L	Check Point
C0161	Brake Switch	X	SW failure, Brake lamp
C0245	WSS frequency error	O	Poor Tooth Gear or damage
C0550	ECU malfunction	O	ECU failure

BL BOSCH 5.3 ABS

Troubleshooting

System failure diagnosis

Detection period
A: Initial check
B: No ABS control
C: ABS in operation
D: Diagnostic state
E: Error state

Failure detection
+: Failure detection is possible
-: Failure detection is not possible

Troubleshooting

System failure diagnosis

Failsafe after detecting failure

a) System down, ABS/EBD W/L, valve relay/solenoid valve OFF

B) ABS inhibition, EBD available, ABS W/L ON, EBD W/L OFF

c) Sensor failure in no ABS operation

d) Sensor failure in ABS operation

e) Low voltage

f) Motor in ABS operation

BL BOSCH 5.3 ABS

Troubleshooting

System failure diagnosis

DTC	DTC NO	DTC Description				
		A	B	C	D	E
Line Fault	FL:C0035	+	+	+	+	+
	FR:C0040	+	+	+	+	+
	RL:C0045	+	+	+	+	+
	RR:C0050	+	+	+	+	+
Plausibility Fault	FL:C0035	-	+	+	+	+
	FR:C0040	-	+	+	+	+
	RL:C0045	-	+	+	+	+
	RR:C0050	-	+	+	+	+

☞ 나머지 조건들은 “Failure List of Self Diagnose” 참조

Troubleshooting

System Air-bleeding

1. Same procedure as CBS air-bleeding
2. When air remains inside brake pipe
 - Normal air bleeding procedure
 - Air bleeding with Hi-scan
3. When replacing a new HU(Hydraulic unit, Wet Type):
 - Normal air bleeding procedure

BL BOSCH 5.3 ABS

Troubleshooting



Menu control:

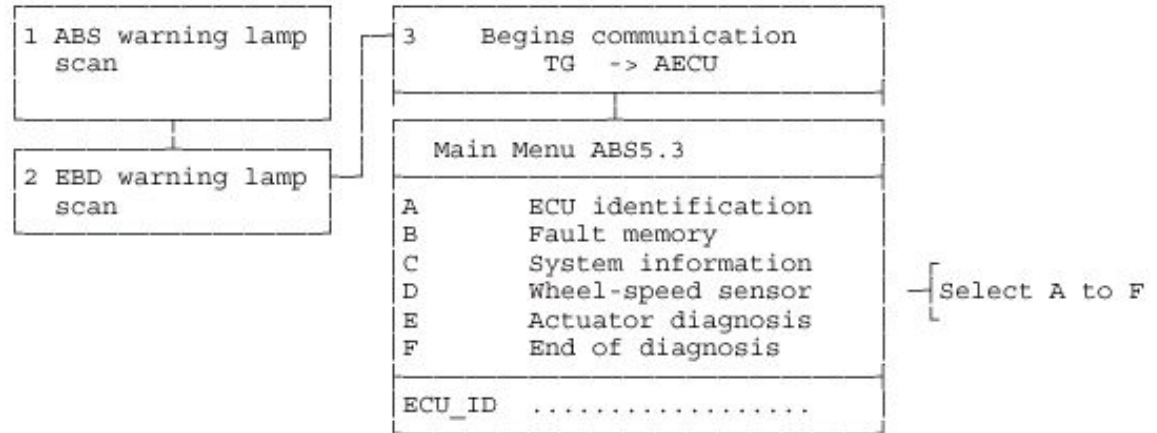

On selection of:

