



Электрическое оборудование ВАГОНОВ

81-765/766/767

Альбом фотографий электрического оборудования вагонов для сдачи
экзамена по профессии «Машинист электропоезда».

Составитель Кулецкий А.Н. V.10-23.



Подвагонное оборудование вагона 81-766.

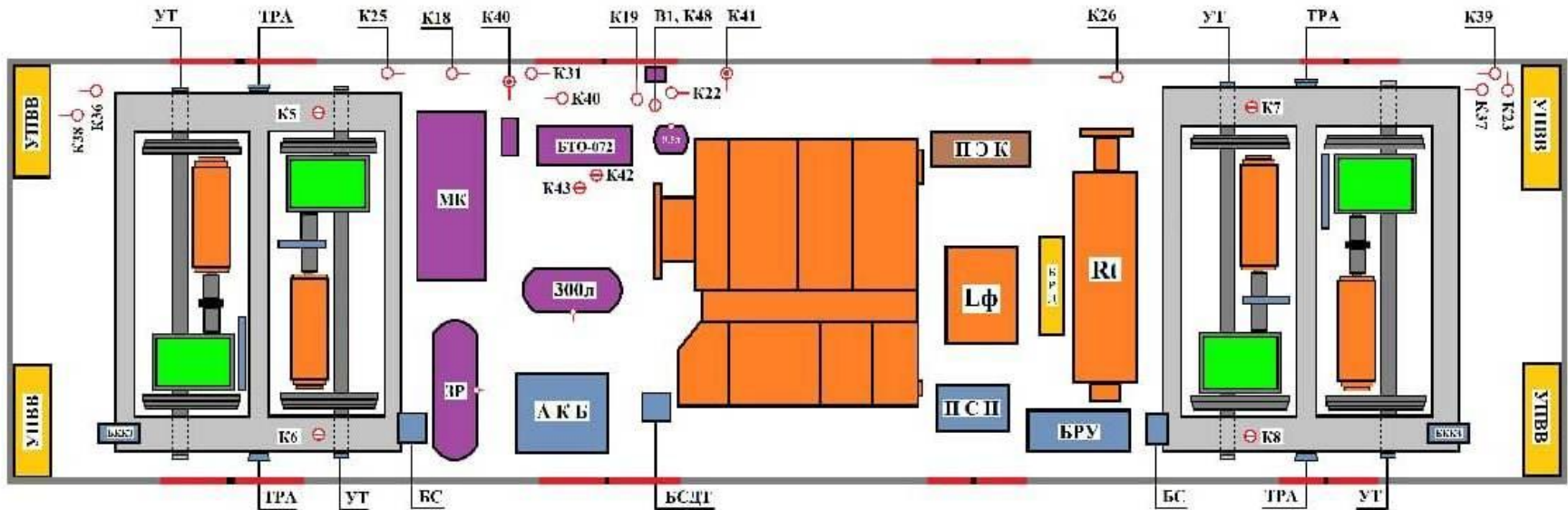
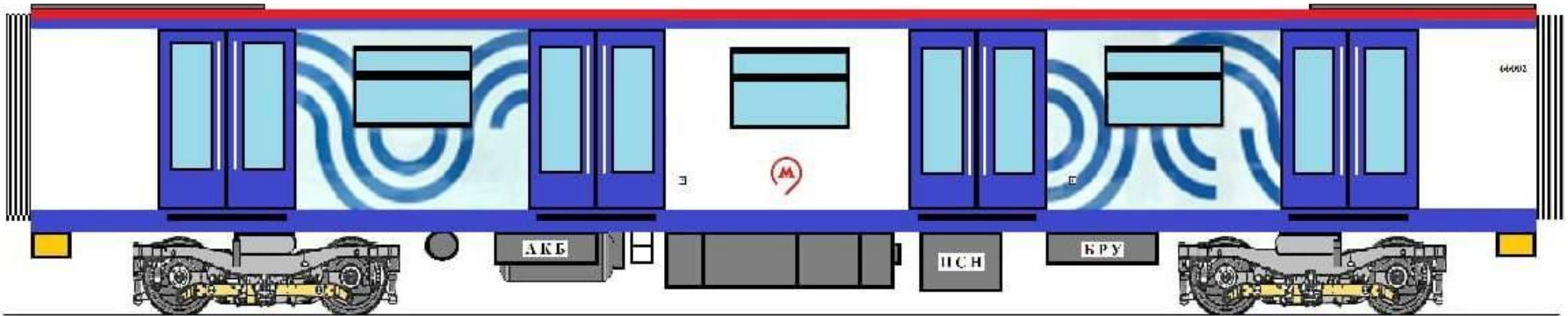

Подвагонное оборудование вагона 81-767.

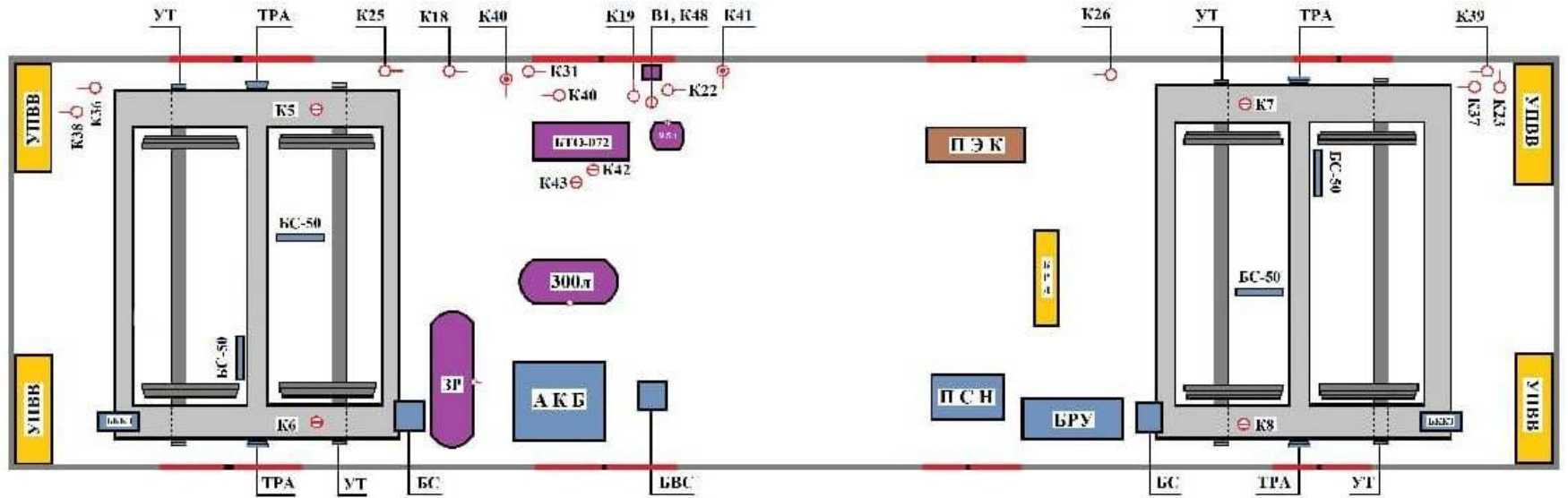
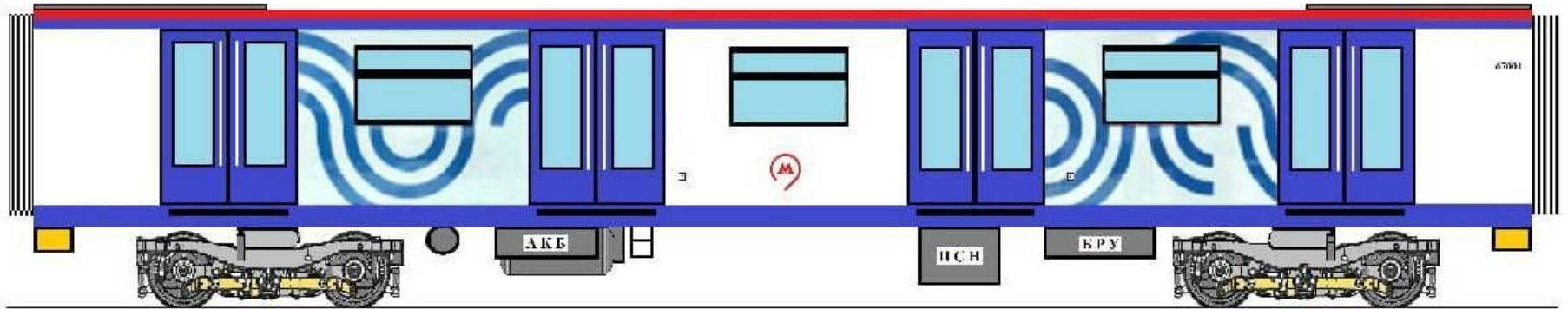

Кабина управления.

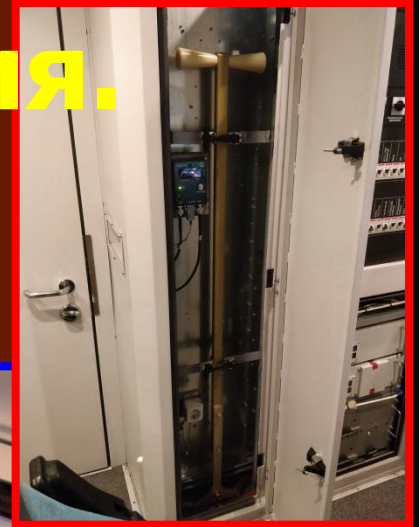

Пульт машиниста основной.

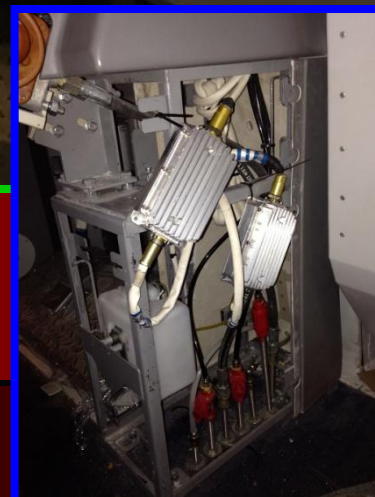

Пульт машиниста вспомогательный.

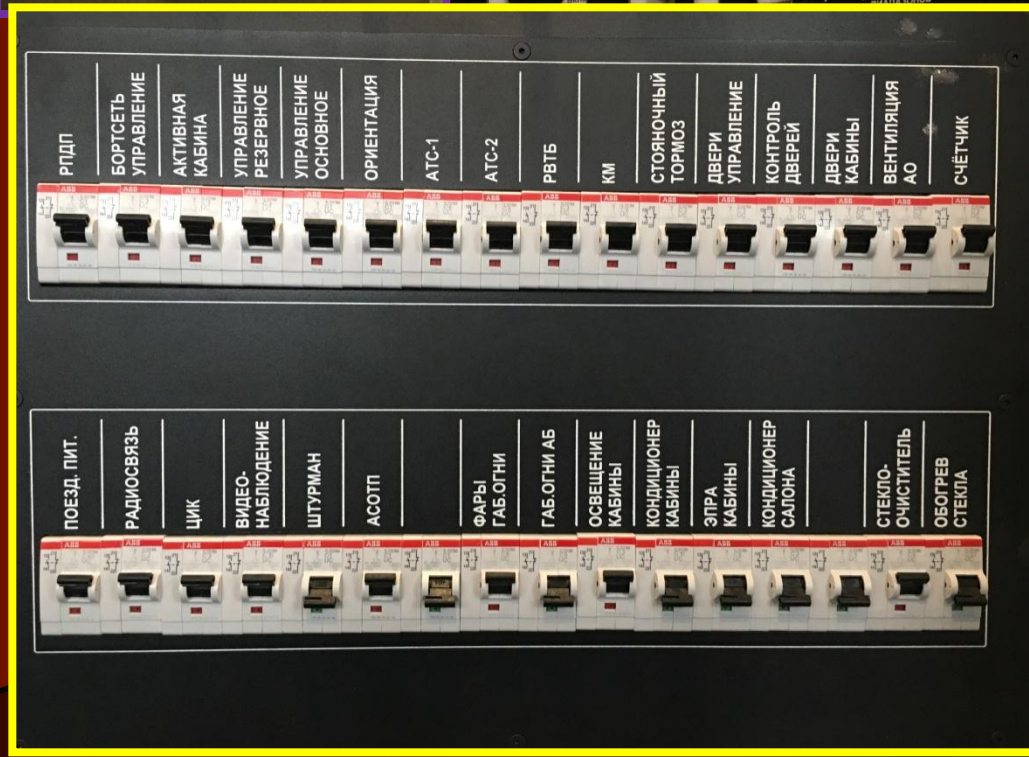
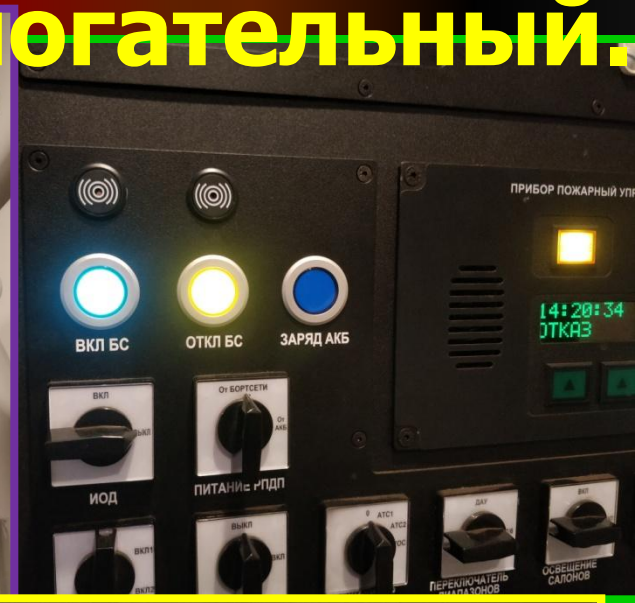
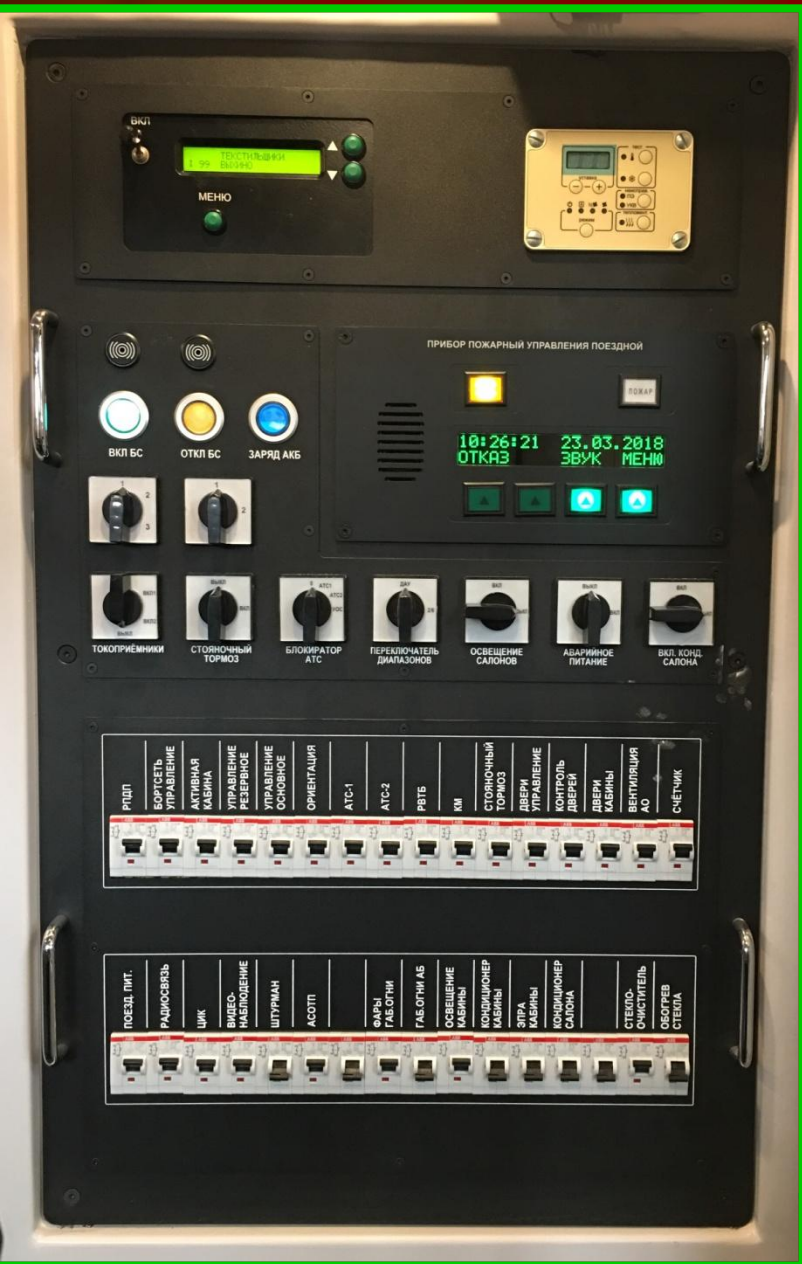

Контроллер машиниста.



Контроллер машиниста «Alfa Union».

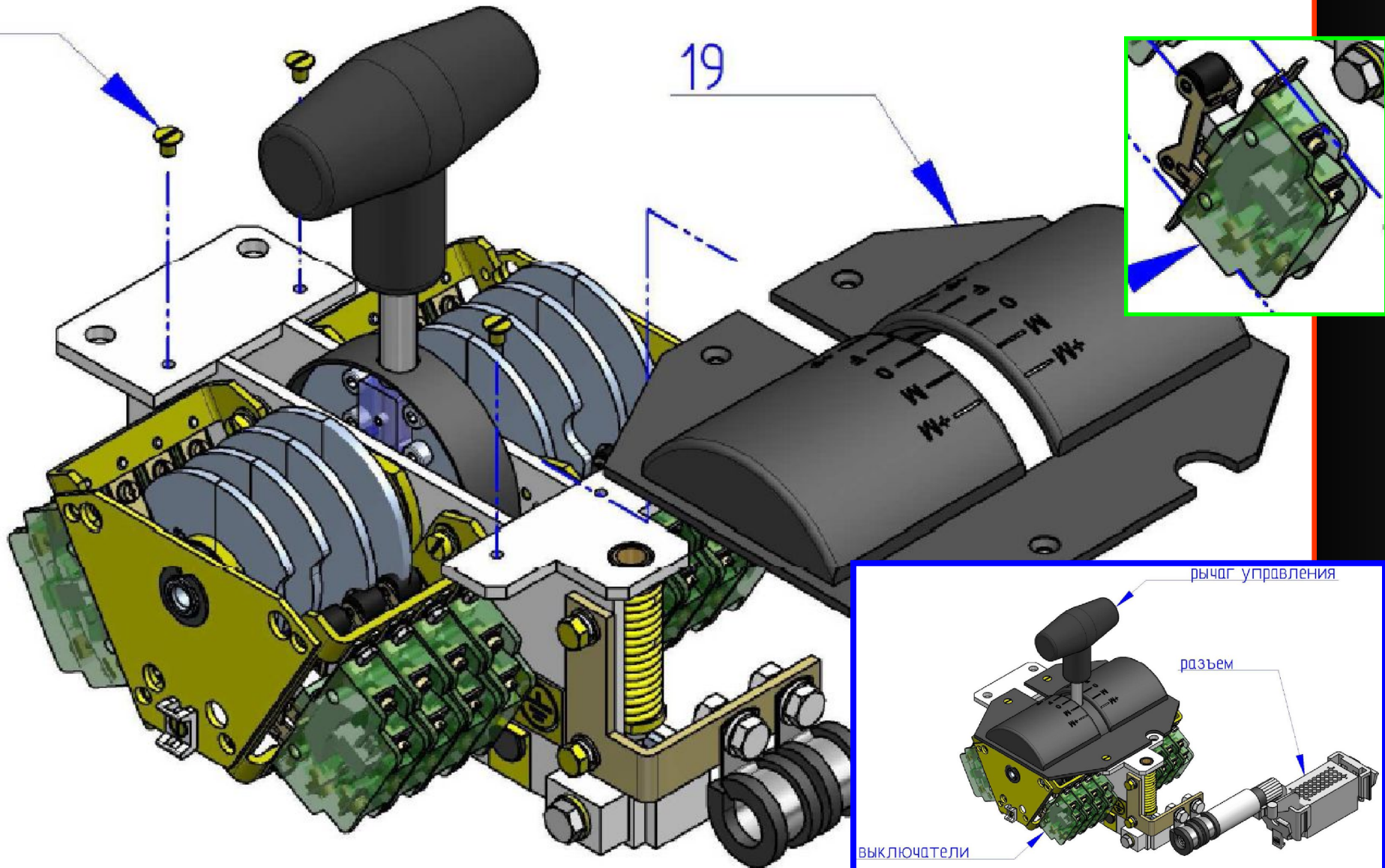

Аппаратный отсек.

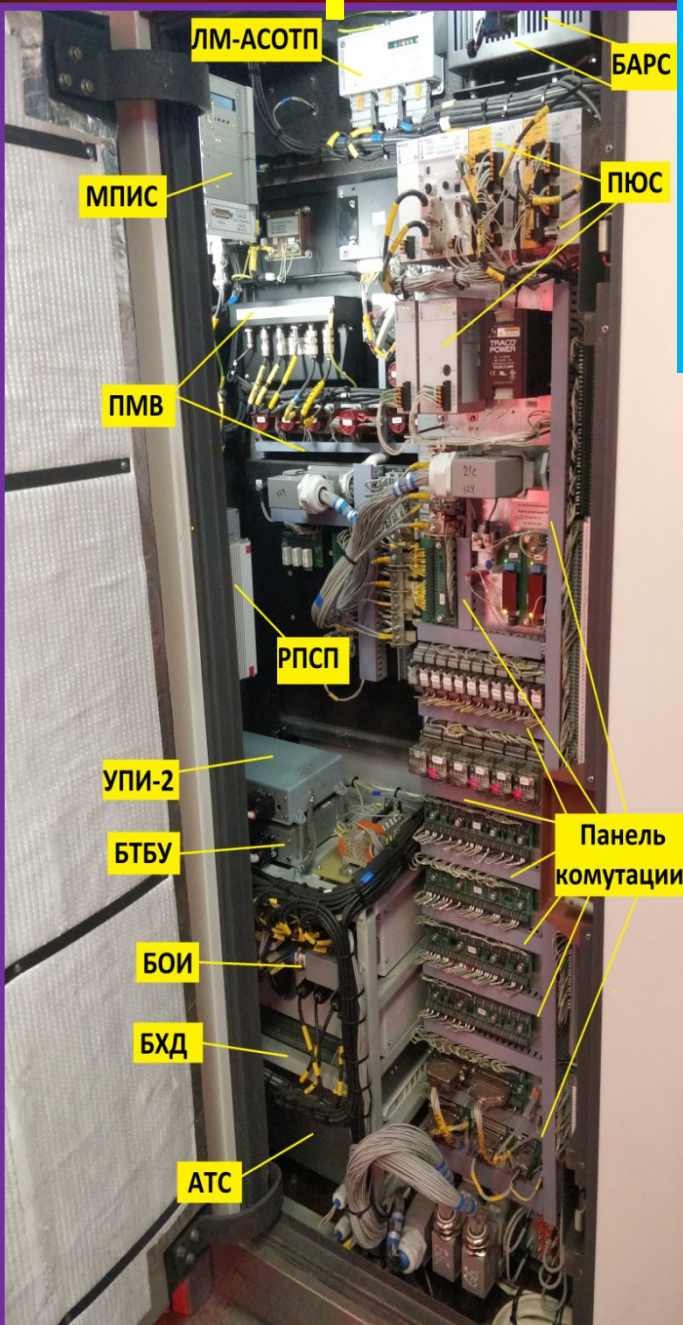

Аппаратный отсек МПИС, РПДП, МУГС, РЛСМ БПФ, РПСР.

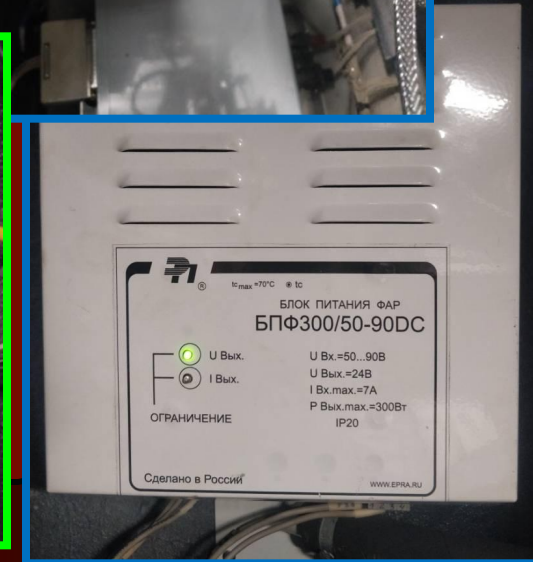

Панель коммутации.



Противоюзная защита.

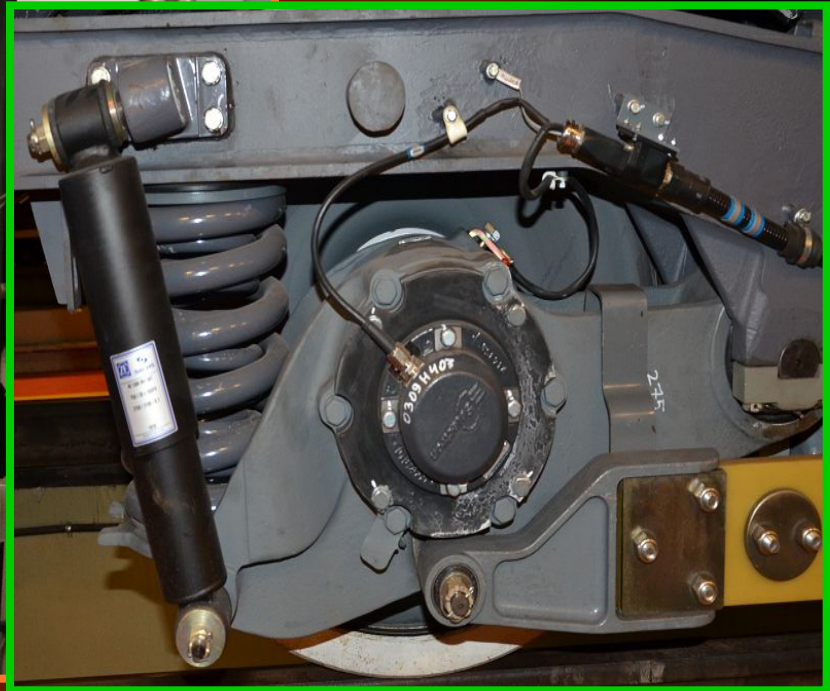
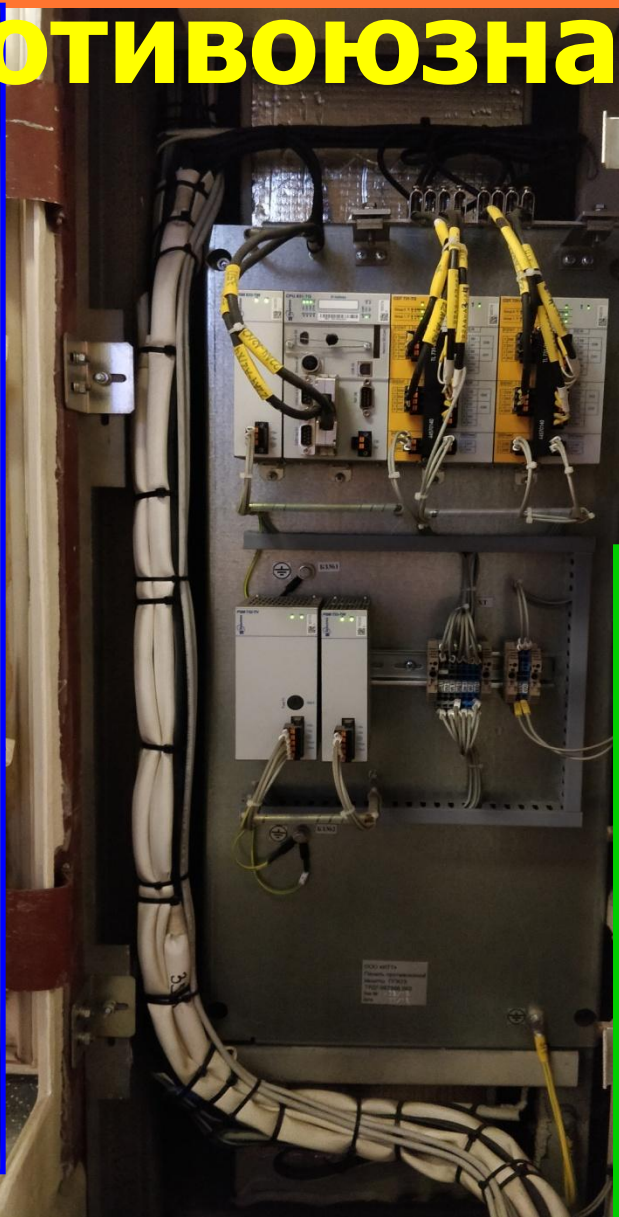

Панель управления вагоном, БУВ-С.

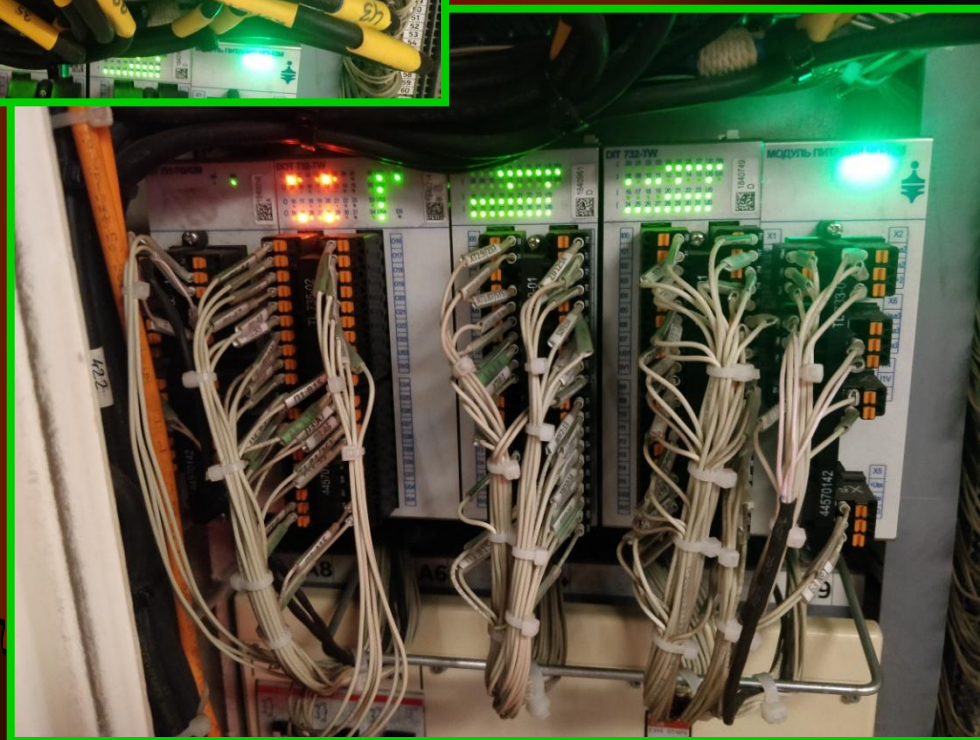
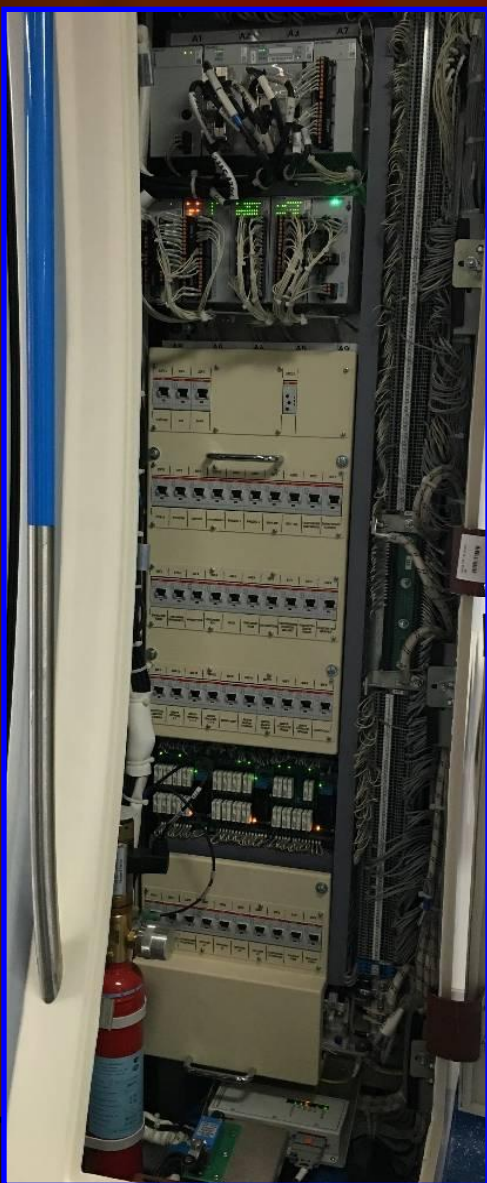

Панель вагонная.

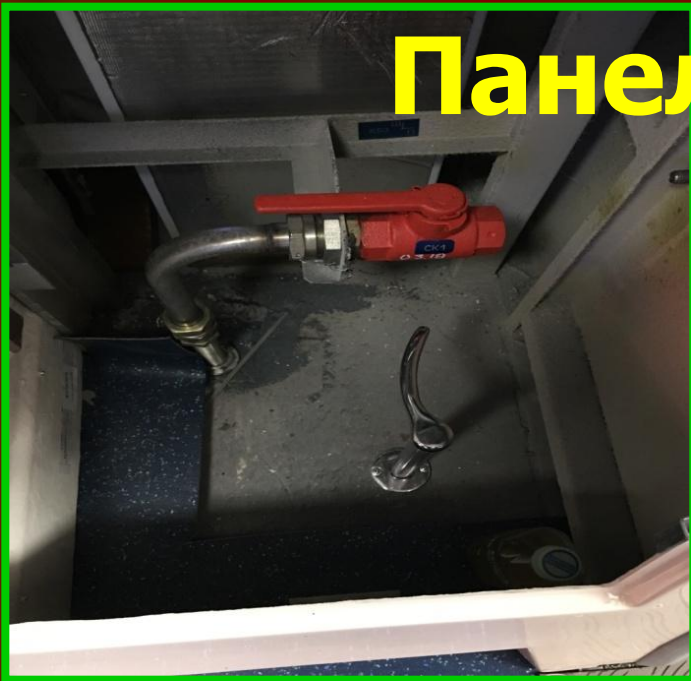

Шкаф пневматический



Фары и габаритные огни.



Система обеспечения климата (СОК-ВМ).

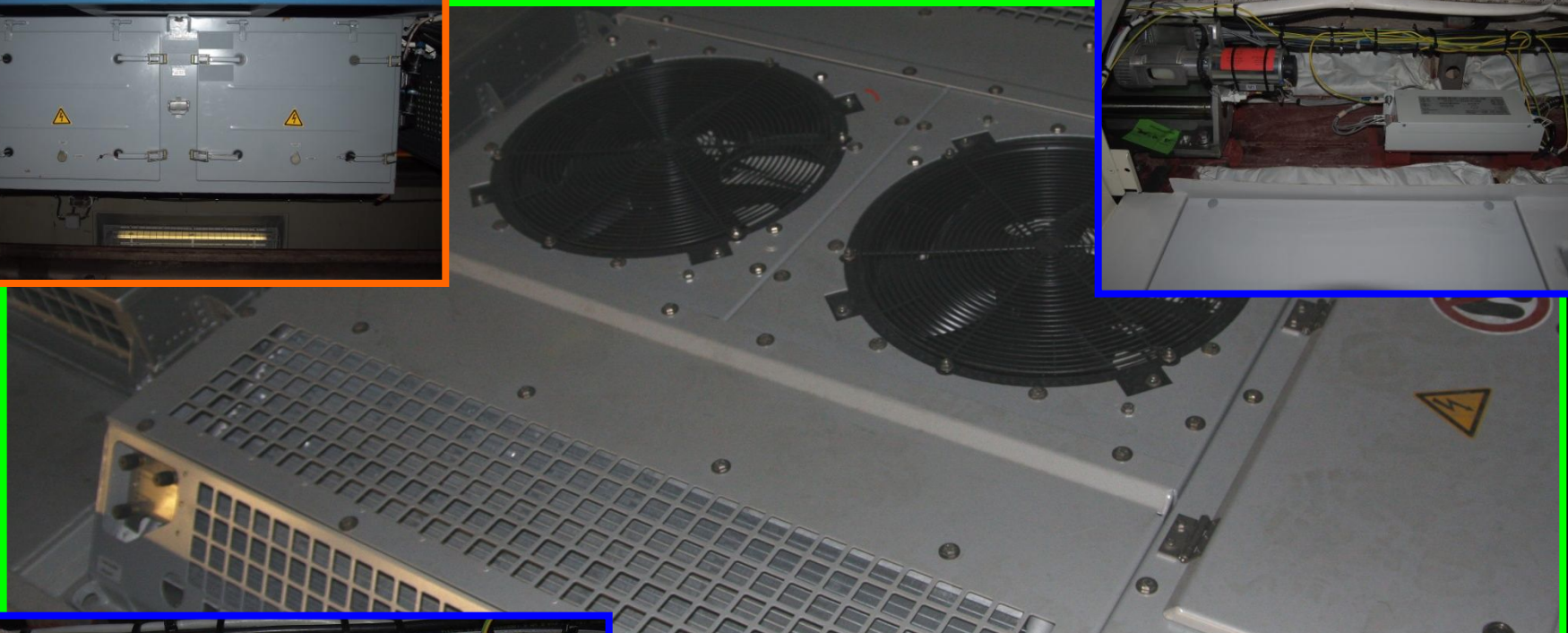

Освещение салона.



Контейнер тягового инвертора.

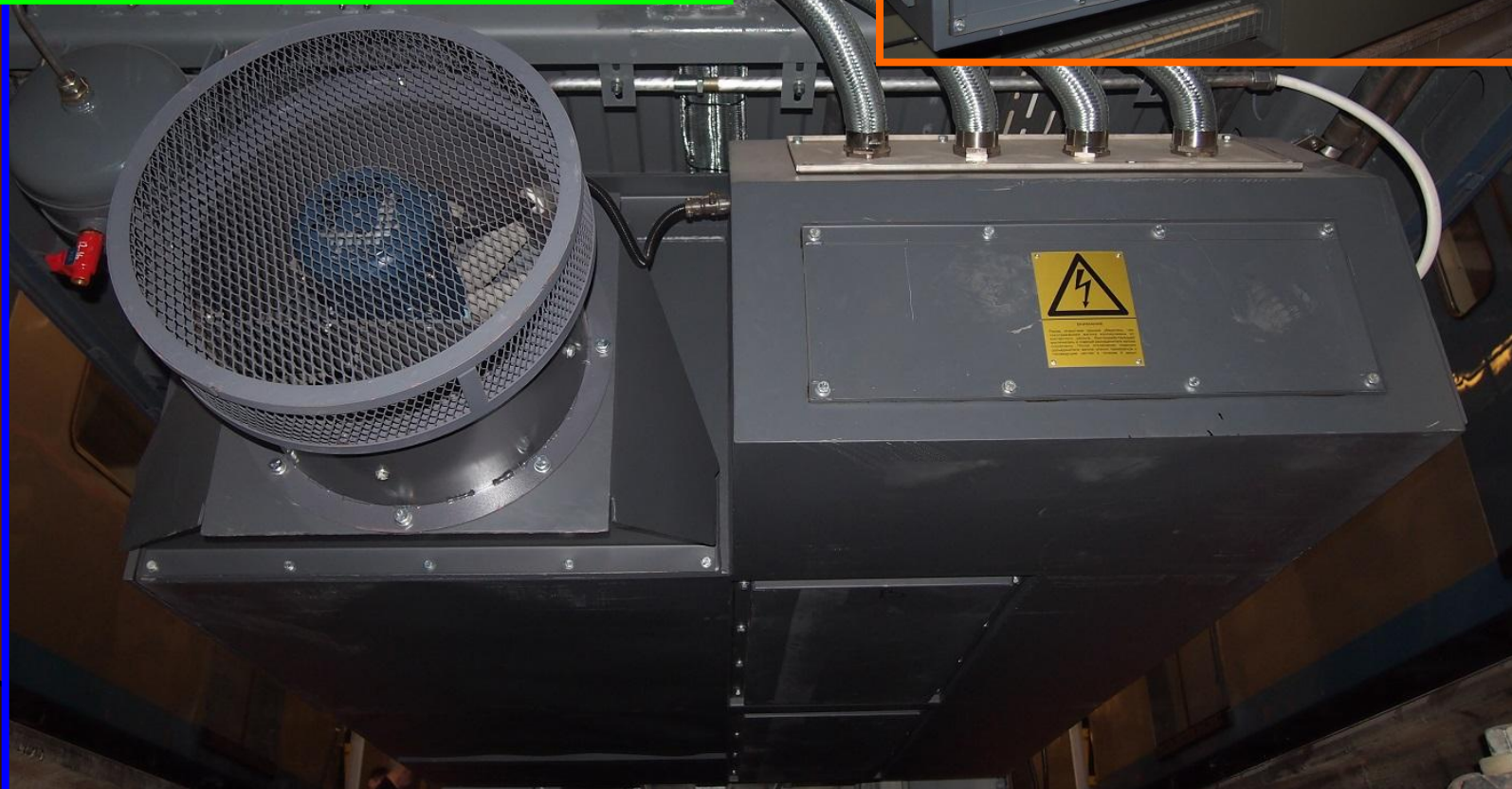

КТИ 3 открытые отсеки.

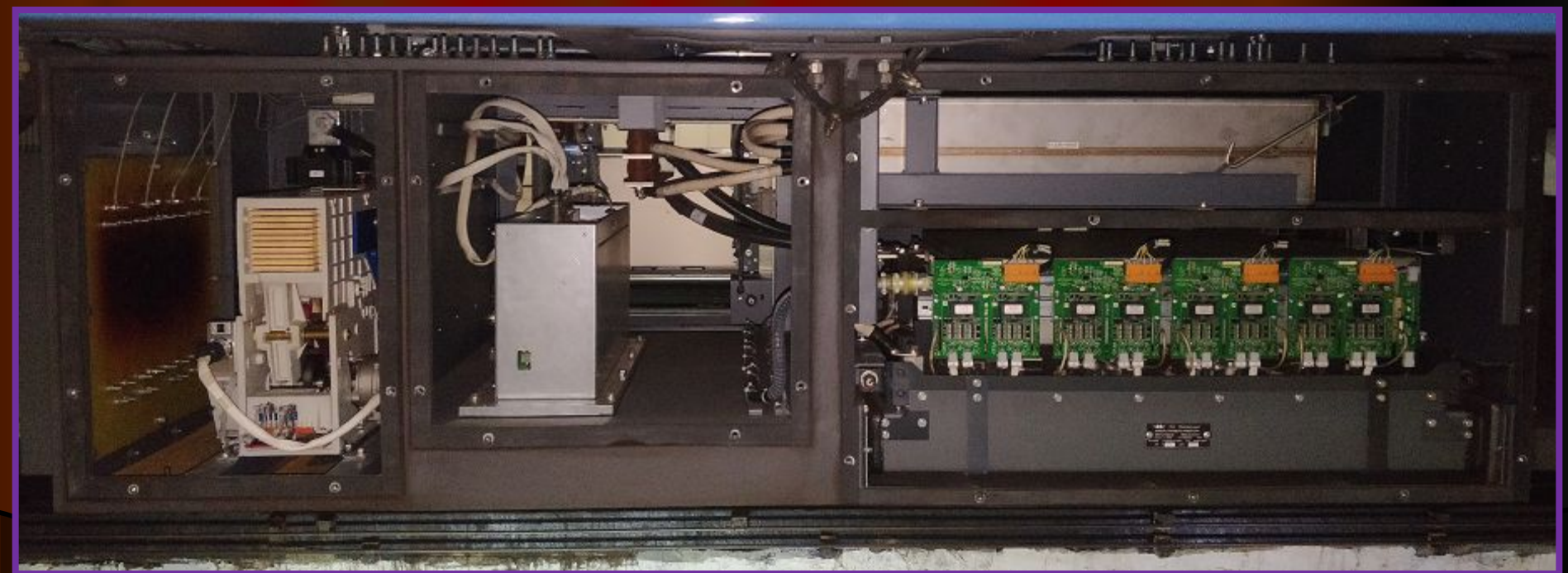
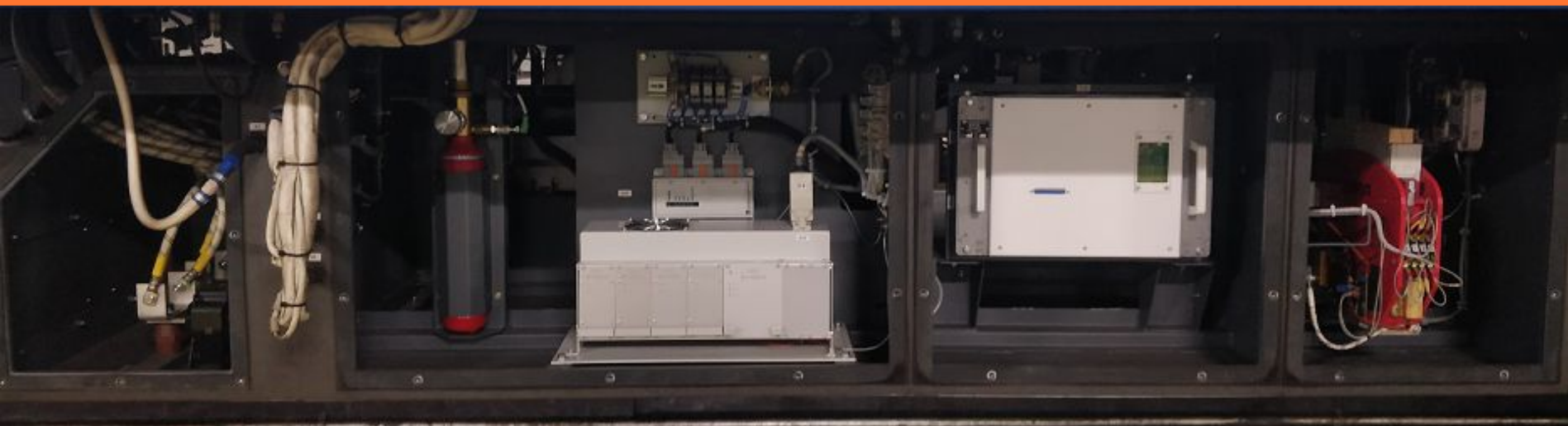

Отсек №1. Контакторов.



Зарядный контактор LTC-250.



Зарядный резистор.

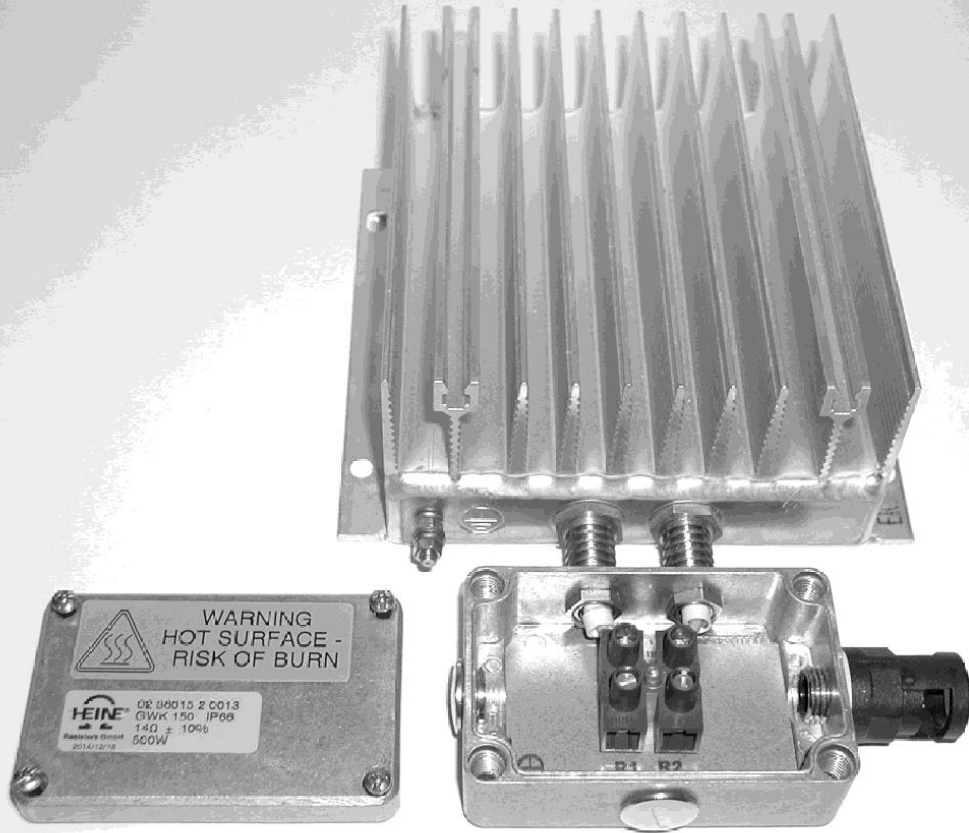

Отсек №2. Блока управления ТЯГОВЫМ ПРИВОДОМ.

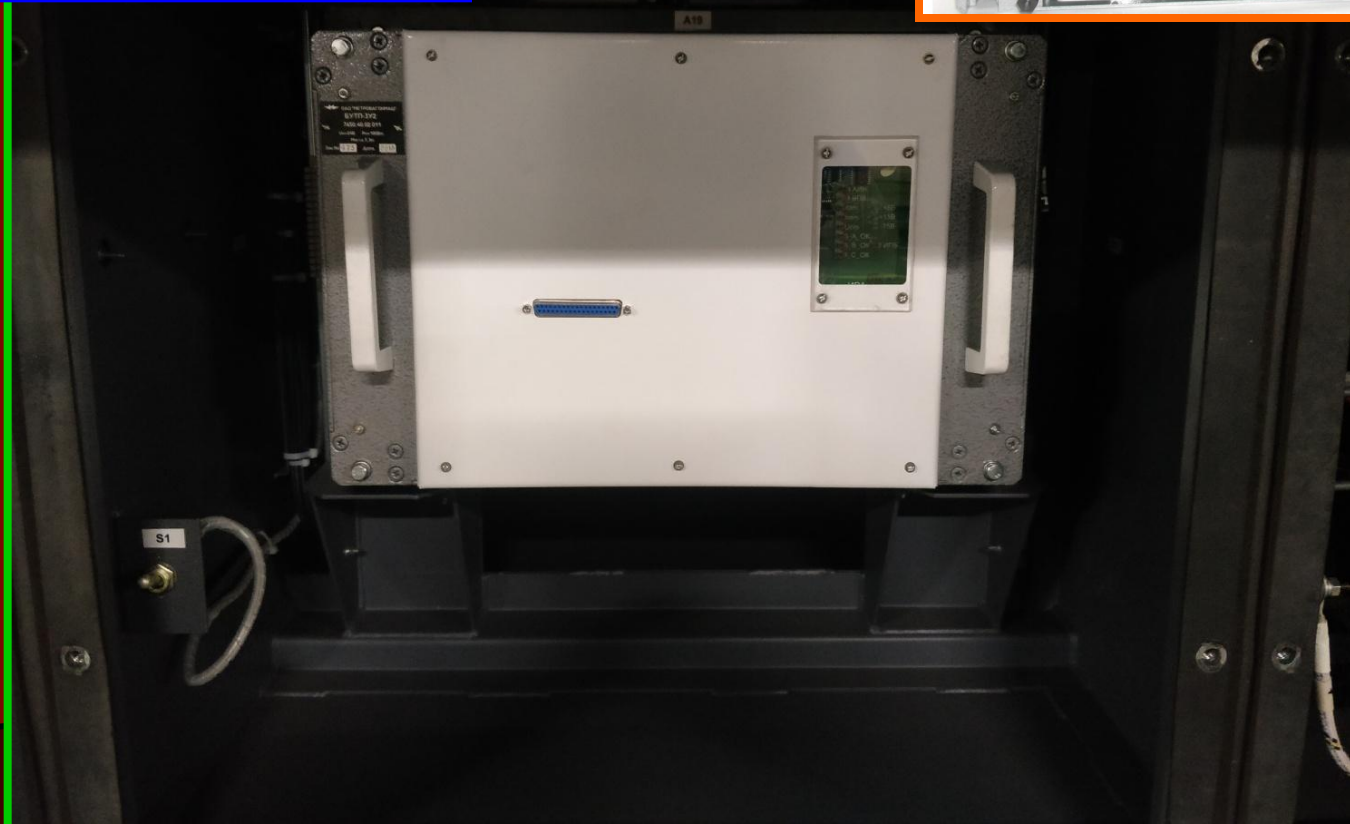
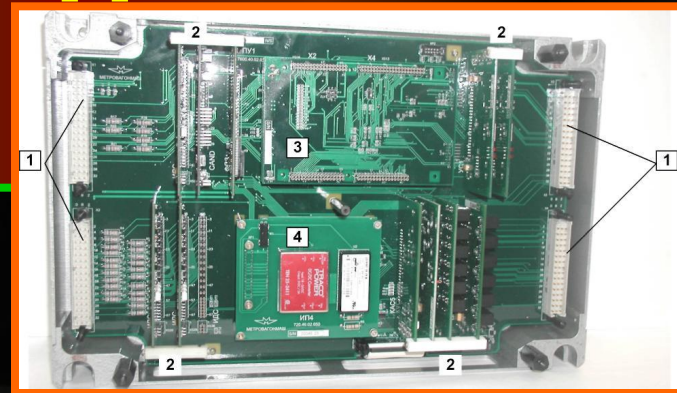

Отсек №3. Вторичного электропитания.

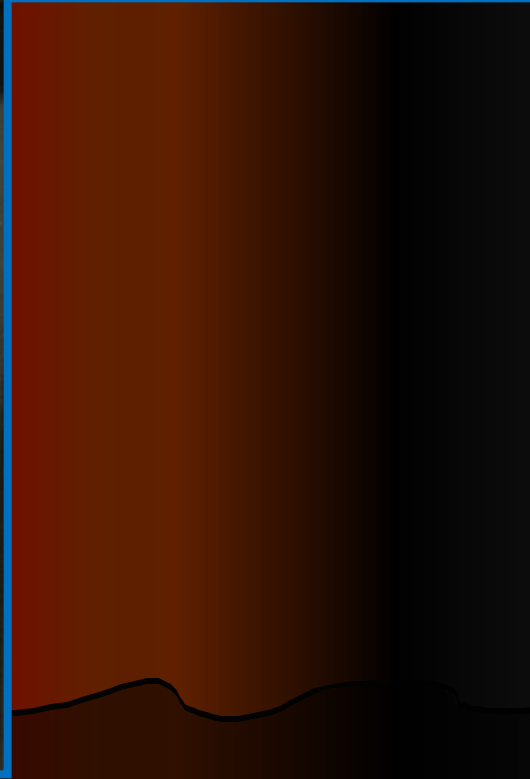
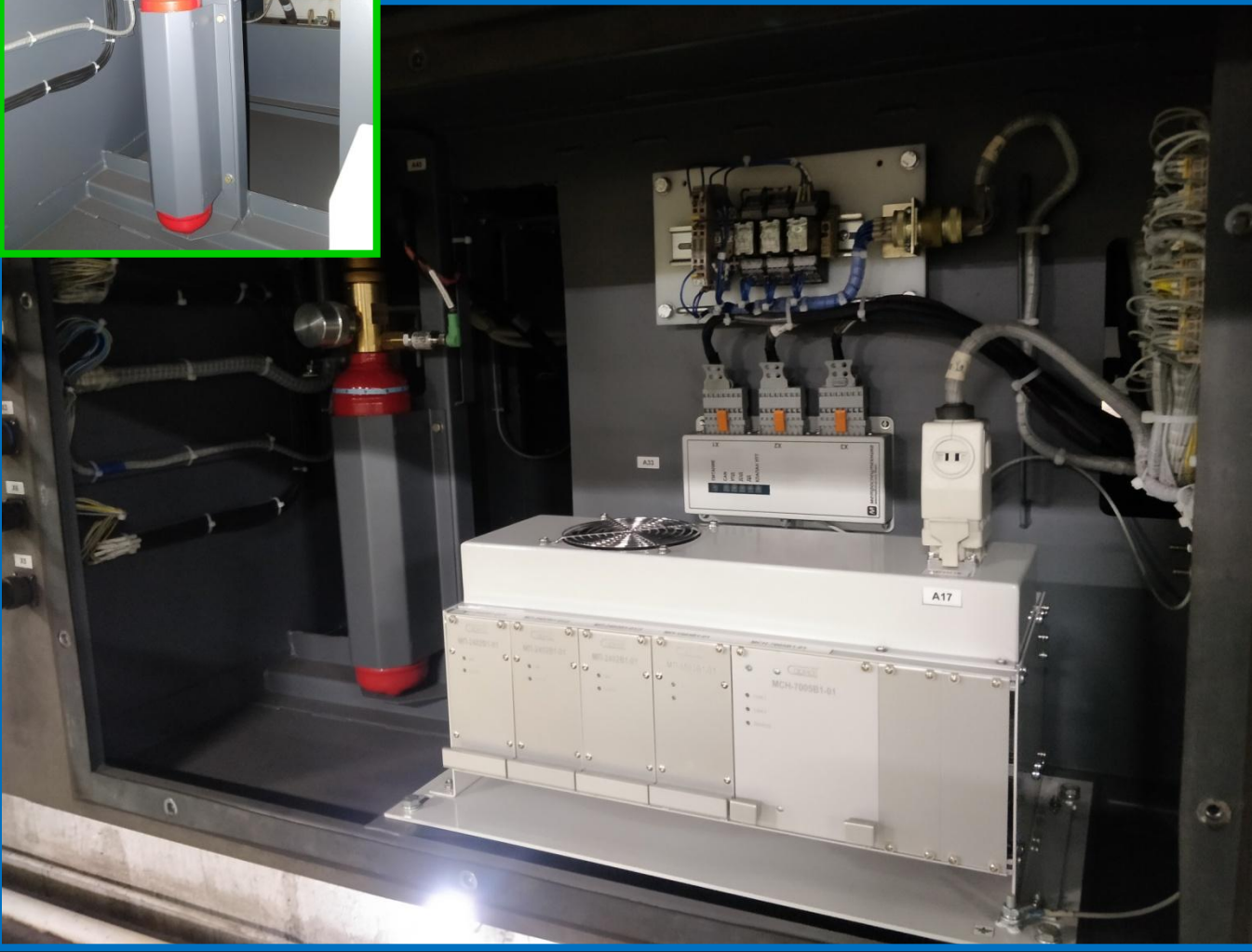

Отсек №4. Датчиков тока.



Отсек №5. Модуля силового инвертора.



12/12/2016

06/23/2016

Отсек №6. Блока инверторов питания вентиляторов (БИПВ).

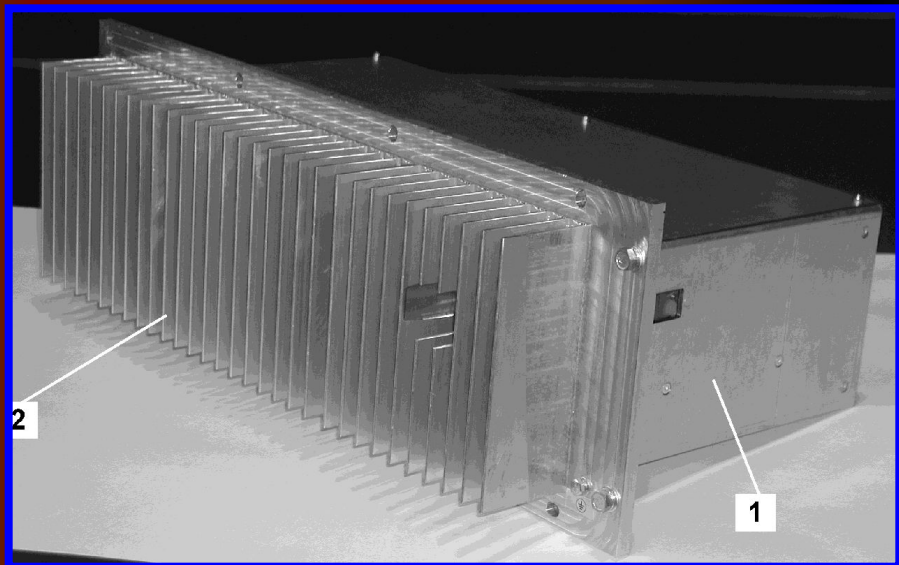
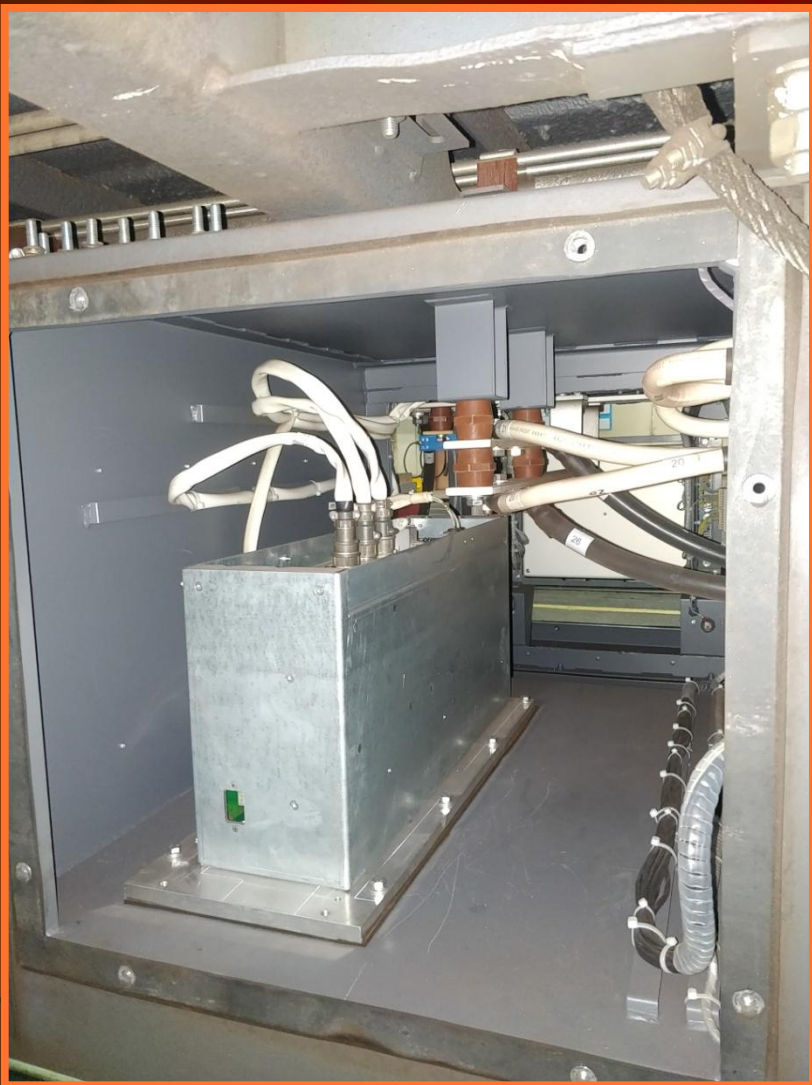

Отсек №7. Быстродействующего. Выключателя.

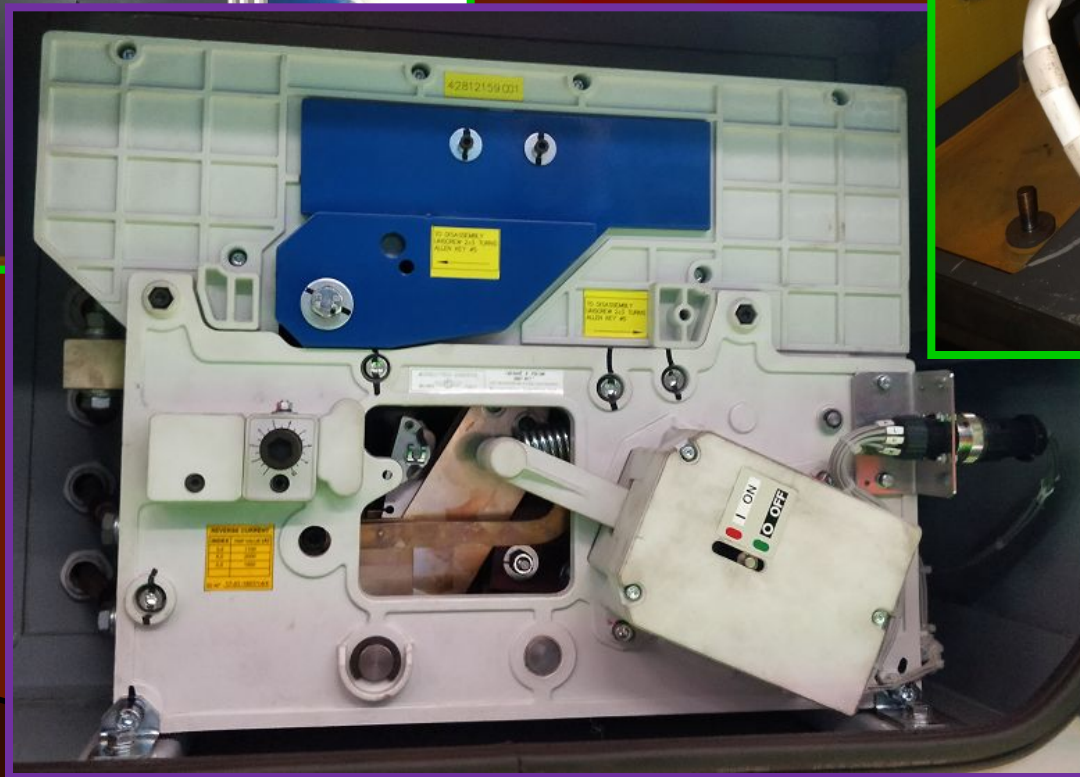
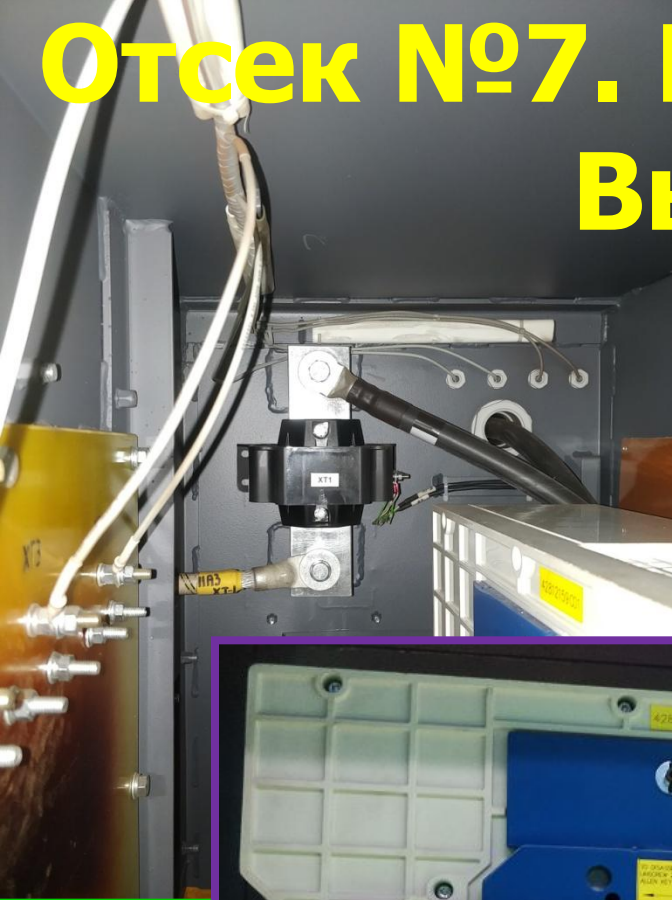

Разрядный резистор.



Отсек №8. Центральный.

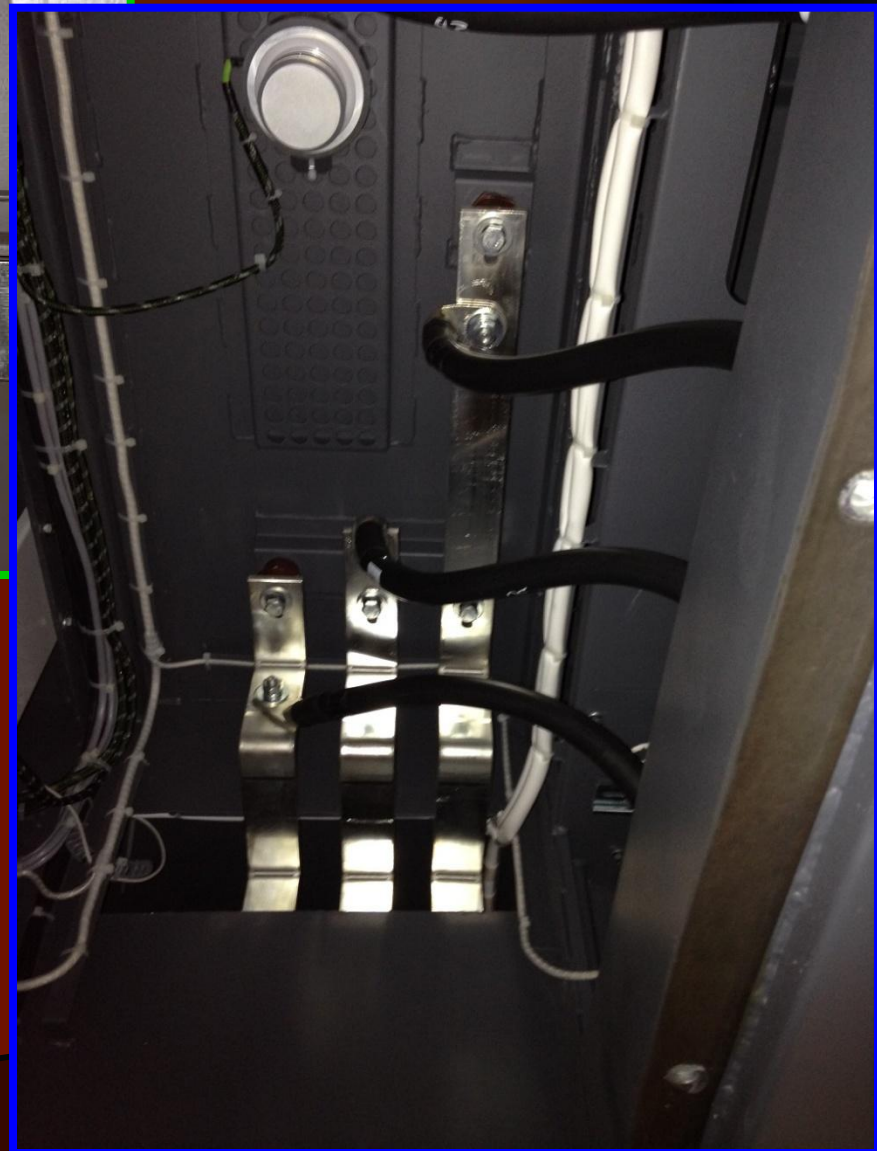

Дроссель сетевого фильтра.

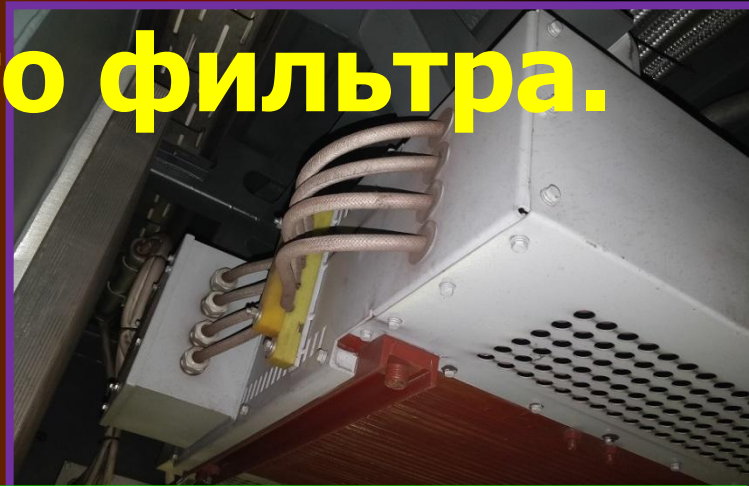

Тормозной резистор.

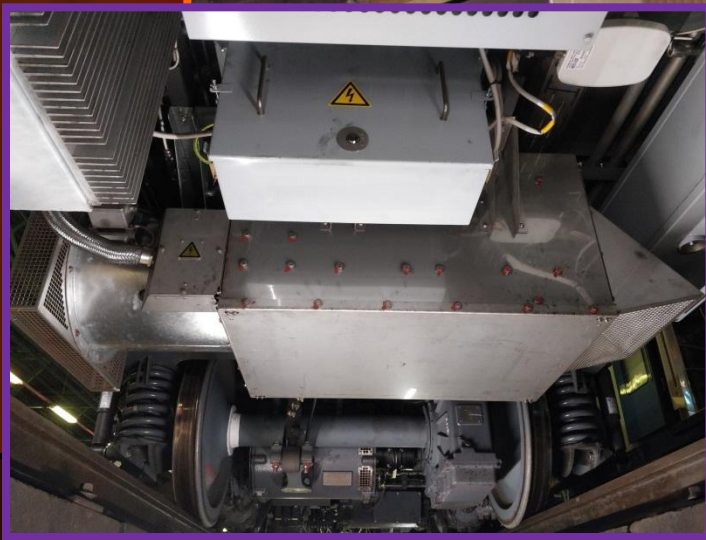
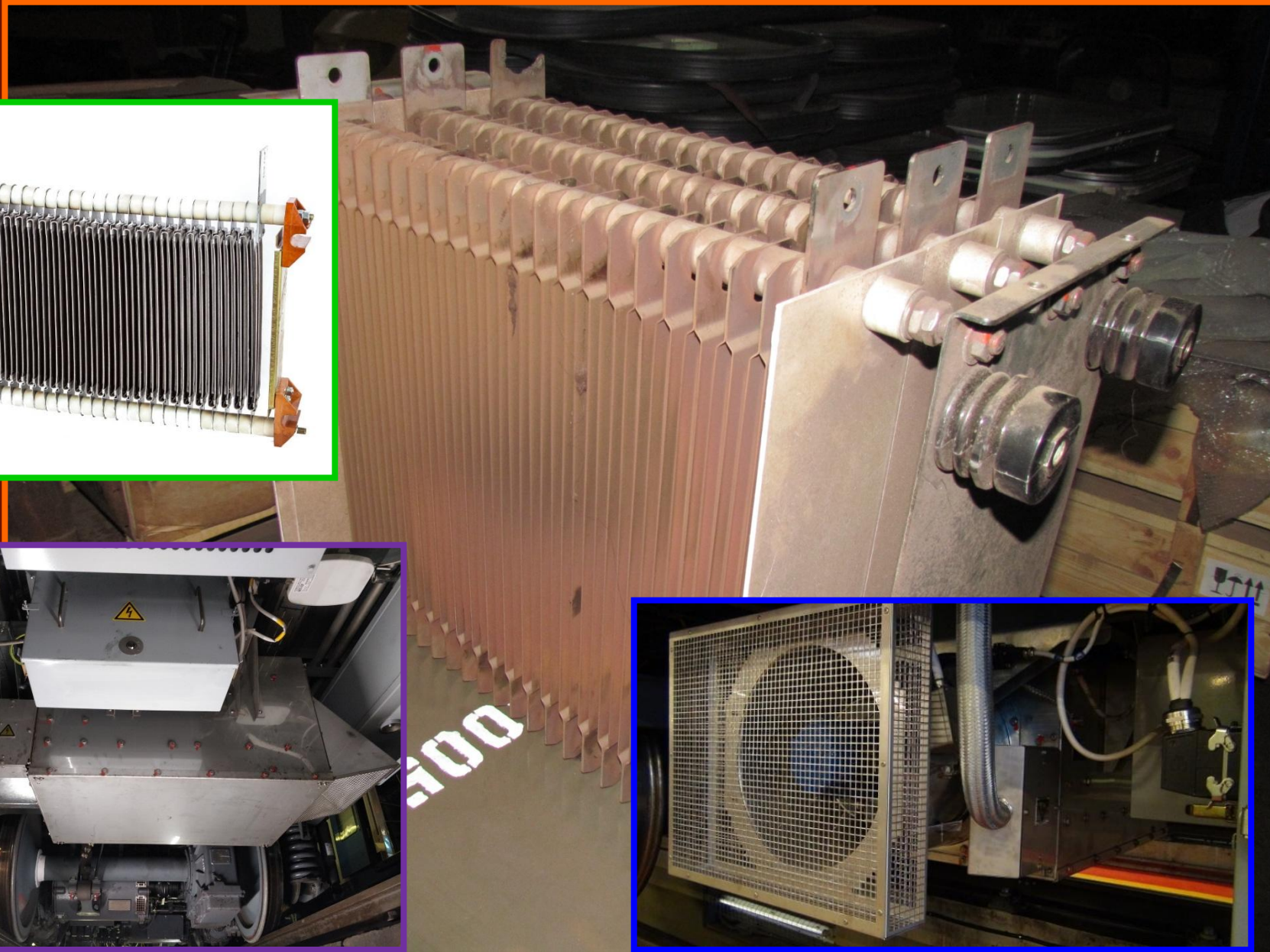

Тяговый двигатель ТАДВМ-280, датчик частоты вращения ДЧВ.

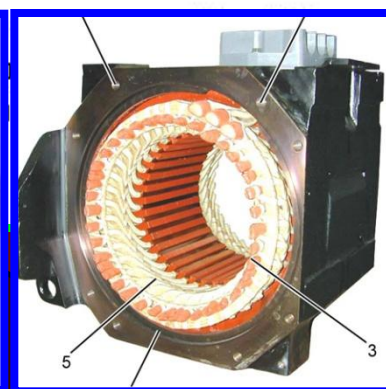
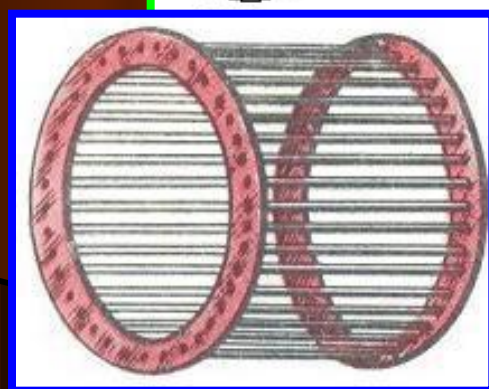
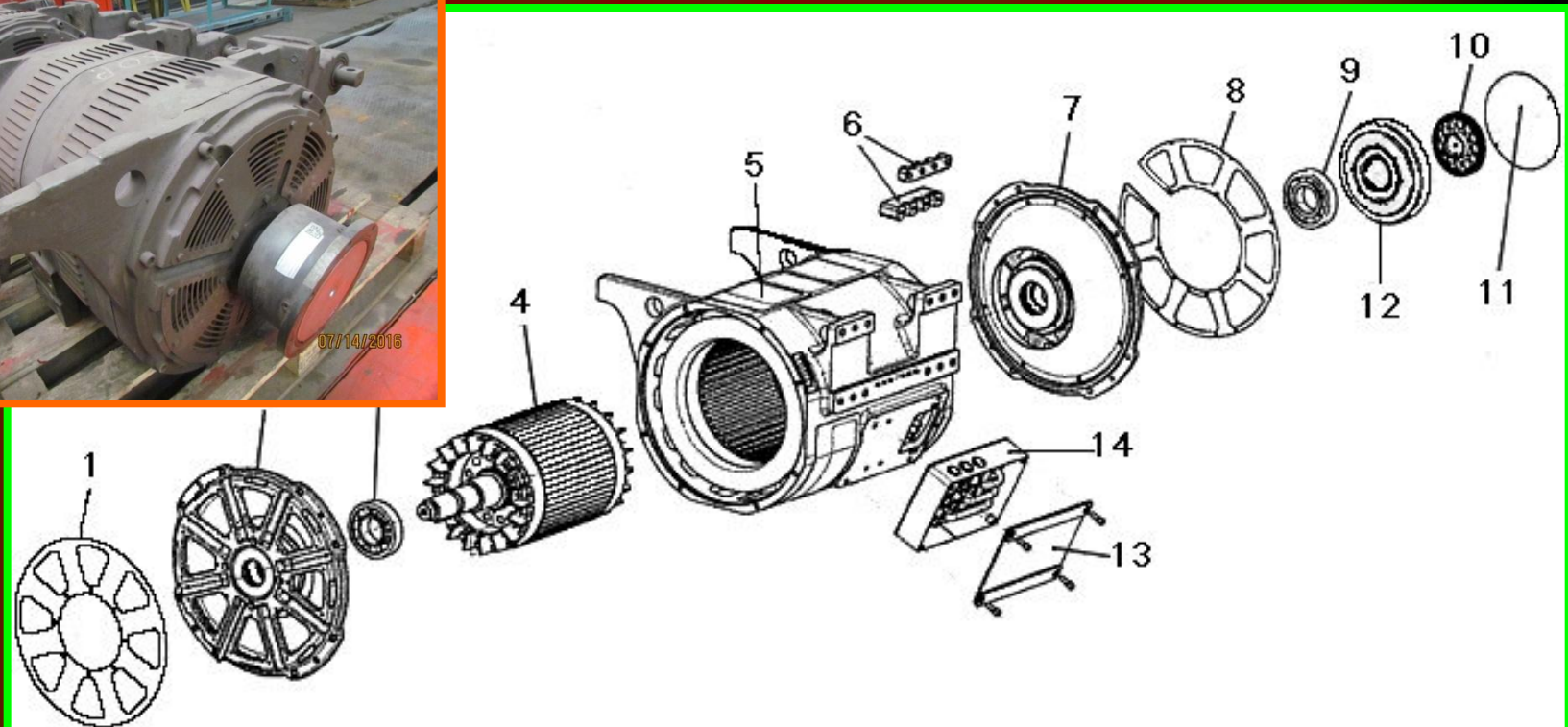

Токоприемник рельсовый ТРА-02.

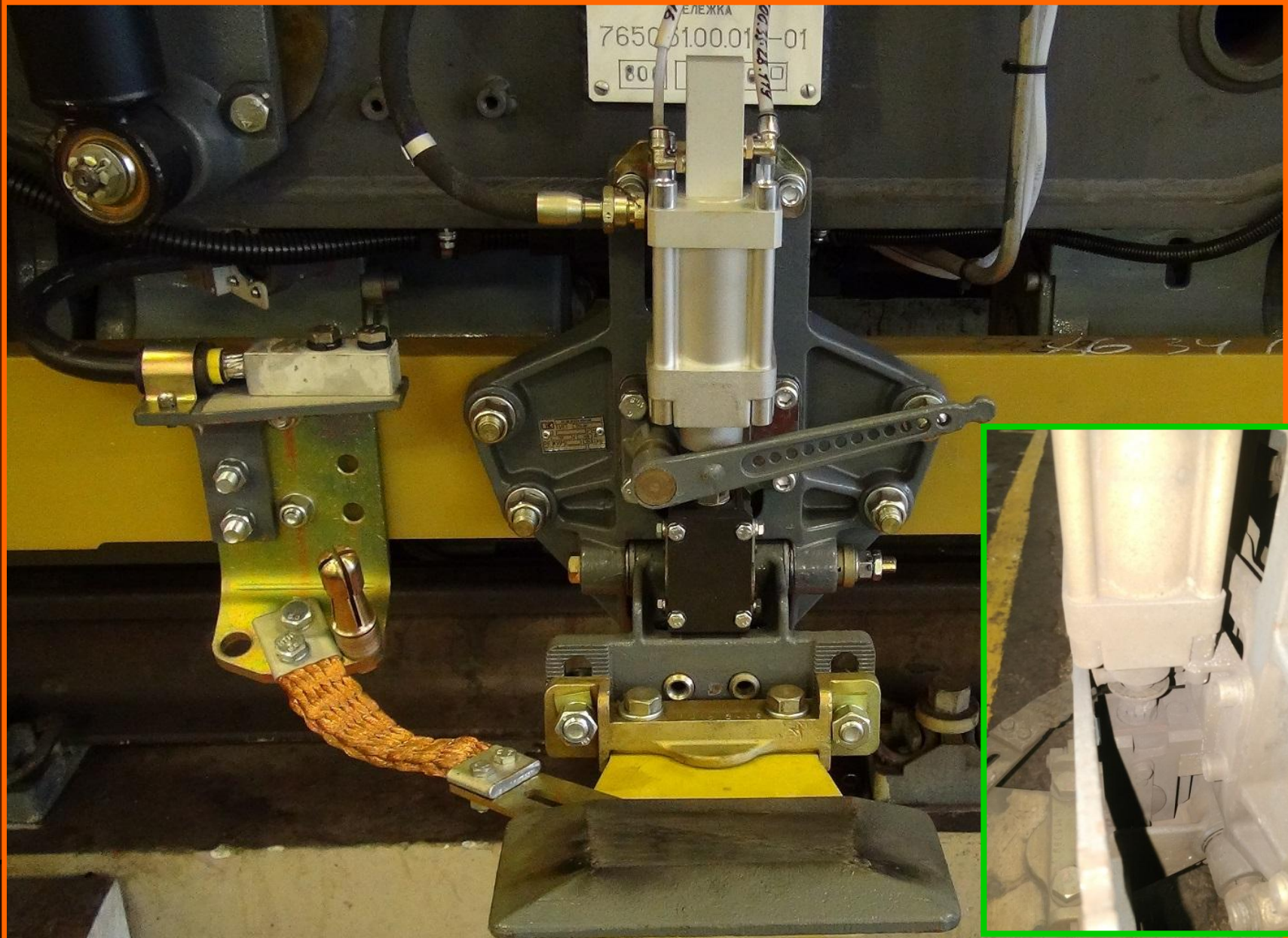

Батарея аккумуляторная A510/55A «Sonnenschein».

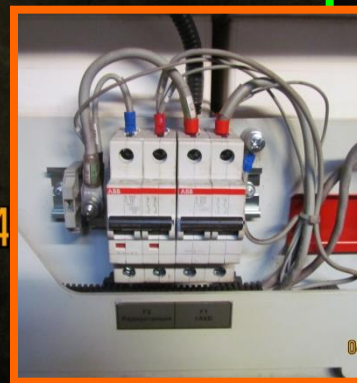

Батарея аккумуляторная А510/55А «Sonnen Schein». внешняя крышка.

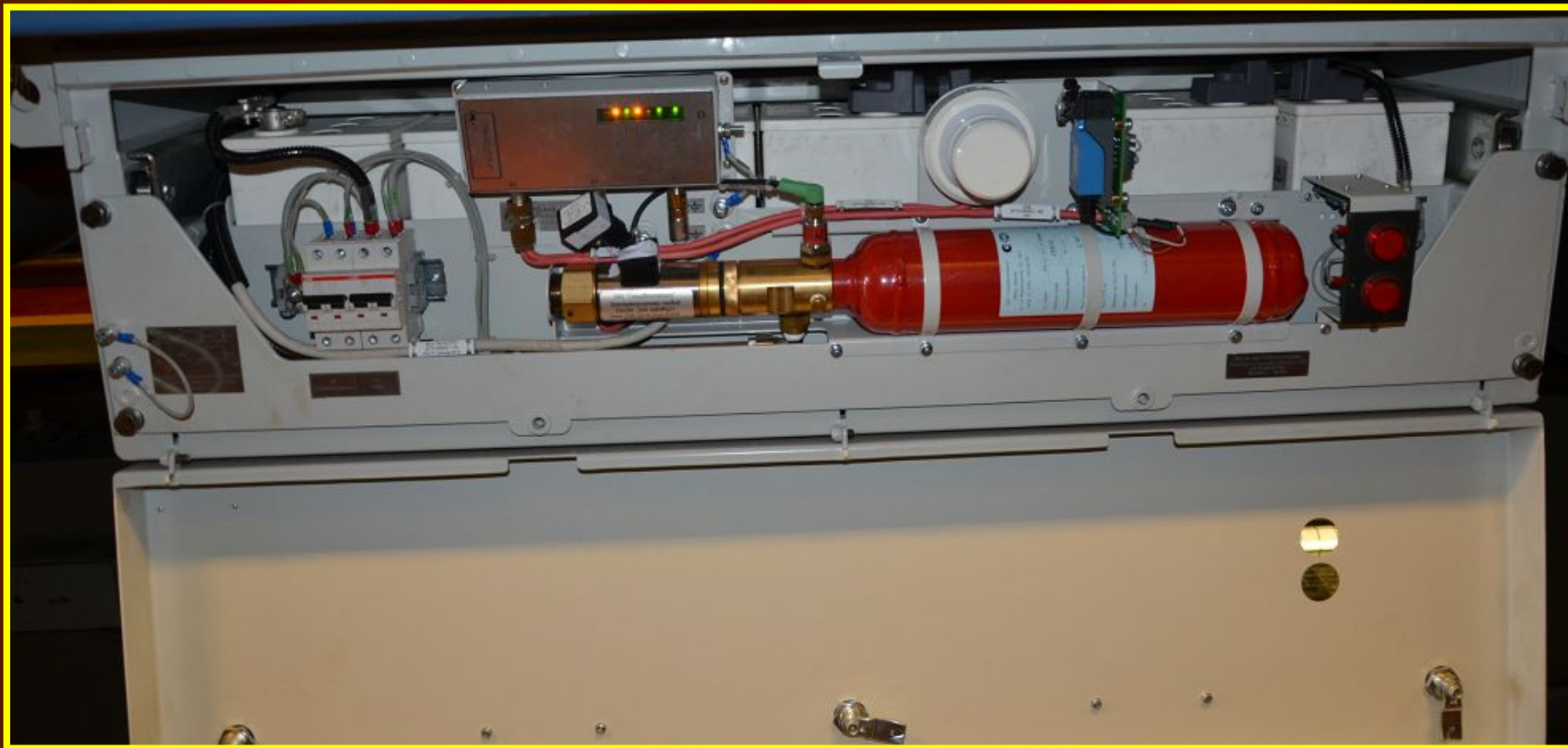

Блоки соединительные: БС «Земляная коробка», БСДТ, БВС.

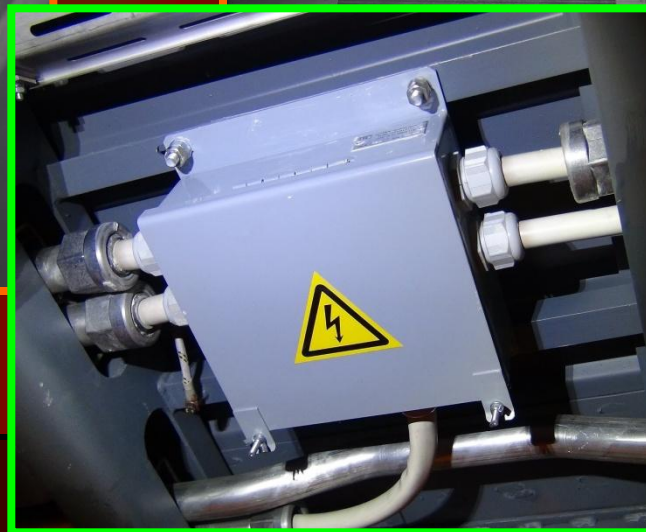
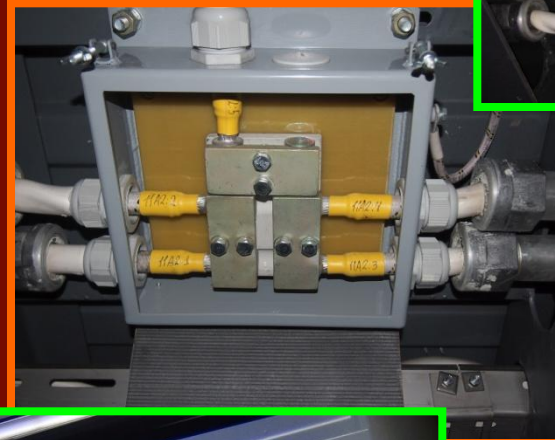

БС 120, БС 50.



Блок распределительного устройства БРУ.



Межвагонные соединения (МВС)



БДН и Вольтметры



Блок разделительных диодов. БРД.

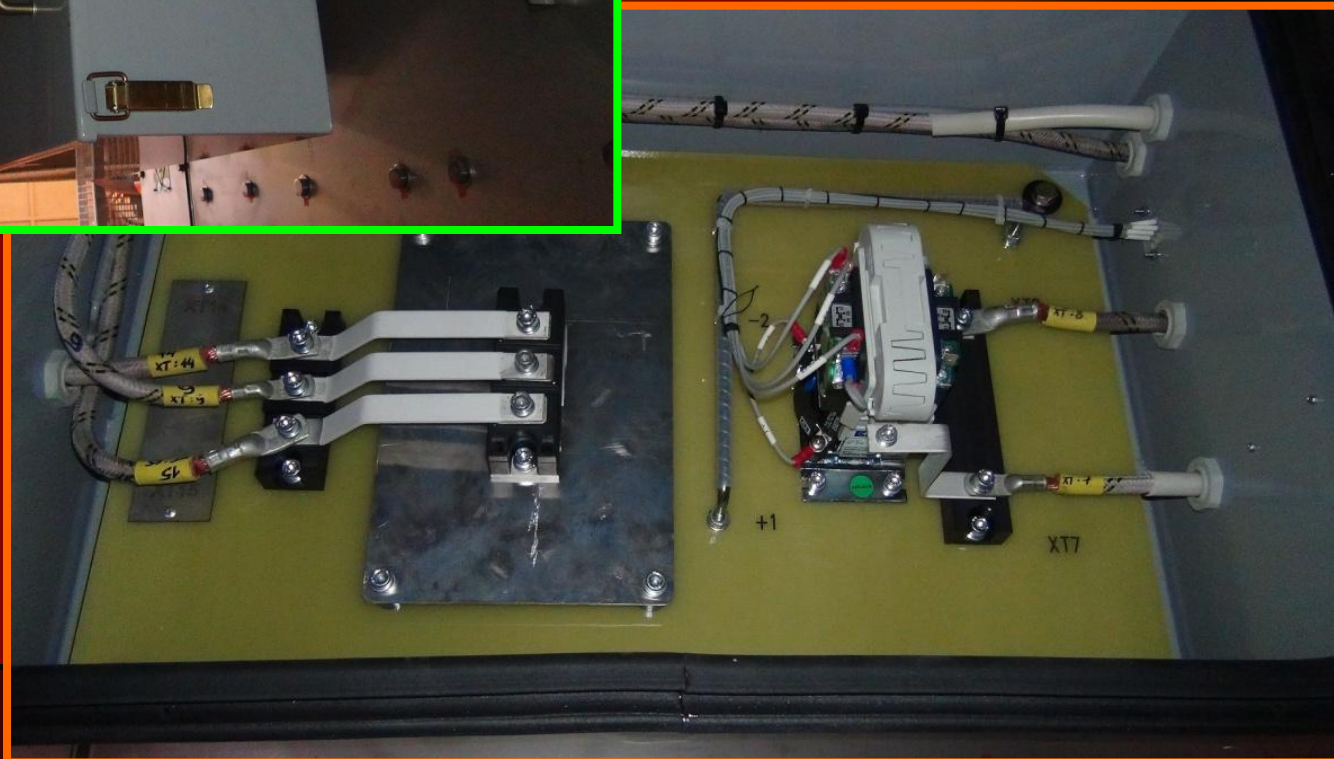

ПСН 765.



Универсальный токоотвод.

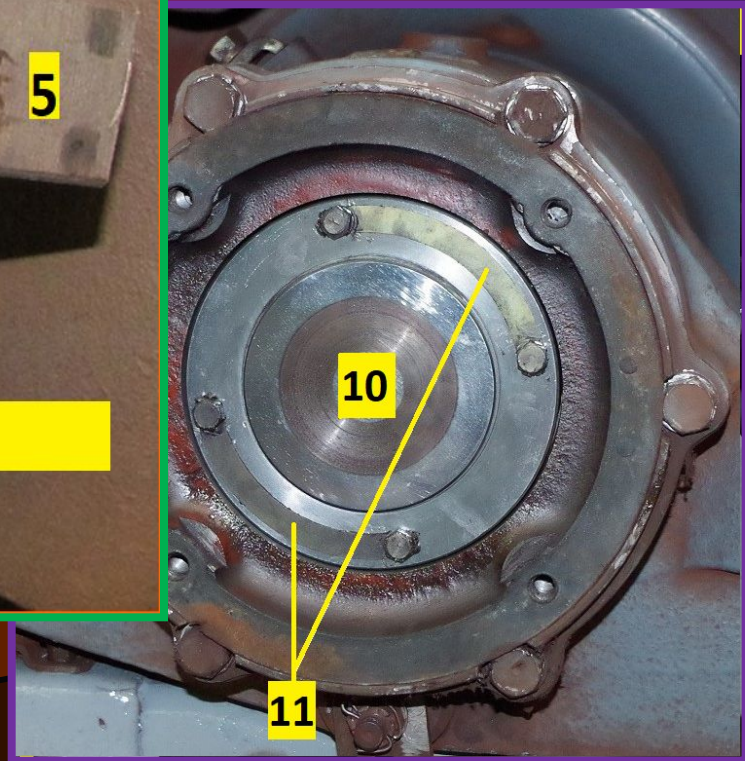

БККЗ и ДКЗ.

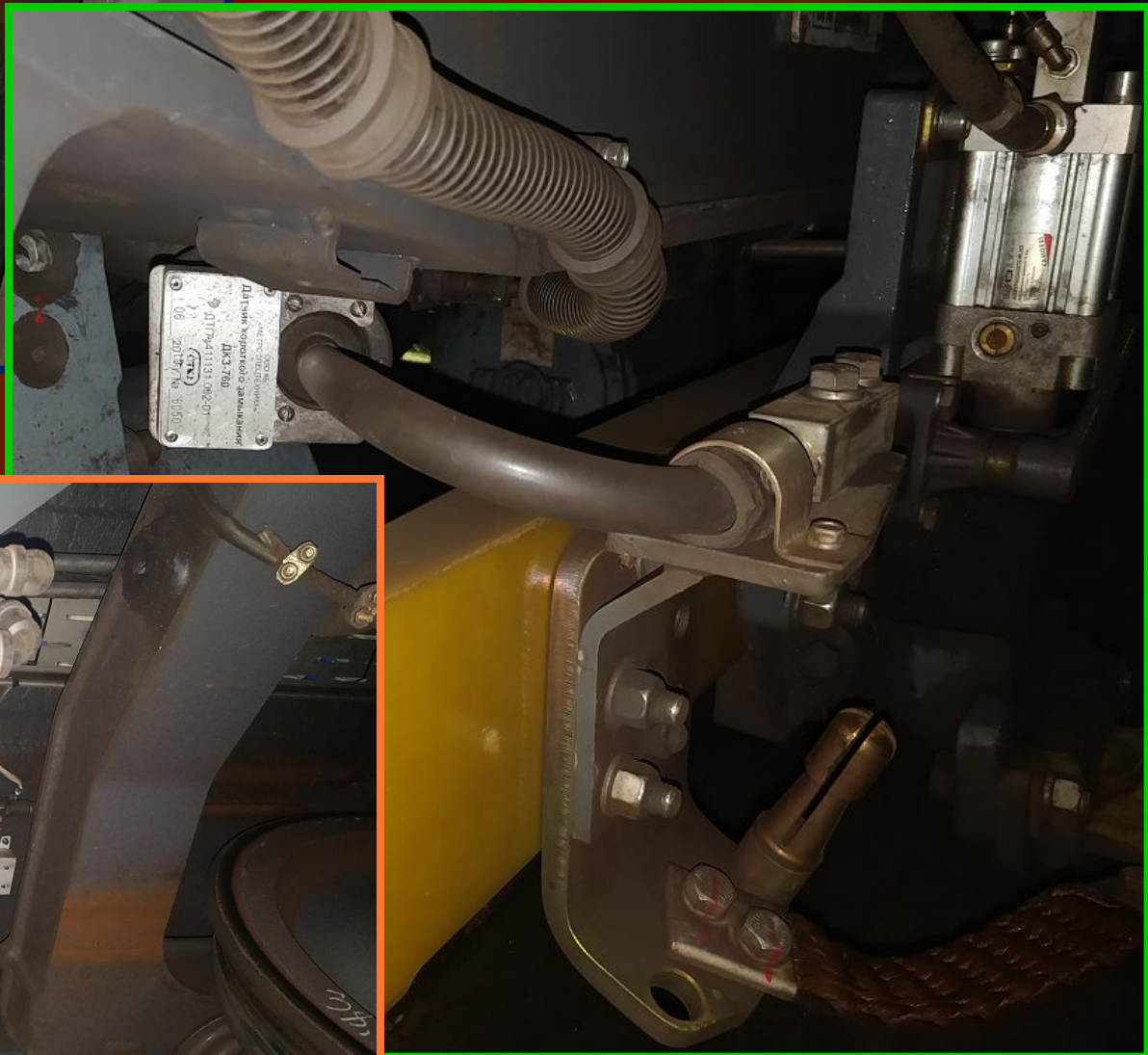

Переключатель НВМ-741.

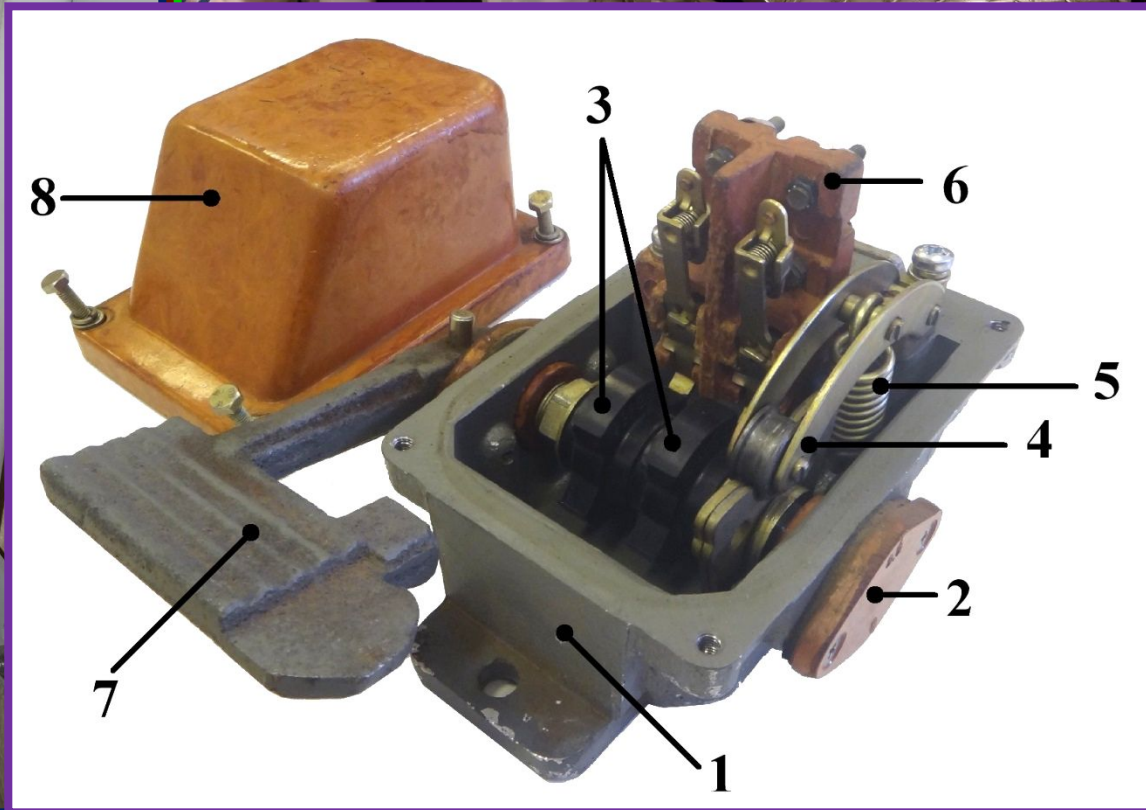

ЗУП и БЭС.

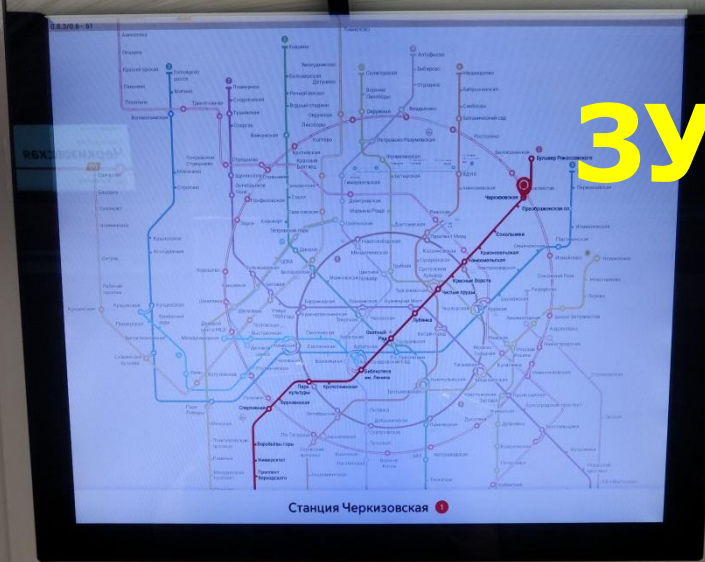

Блок наддверного табло и рекламы.

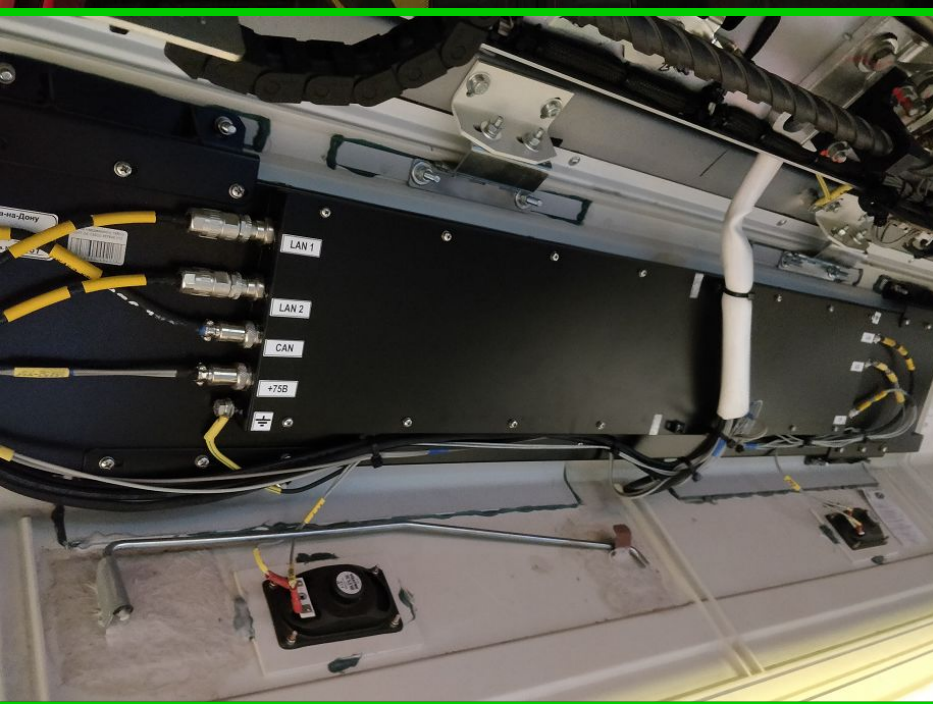
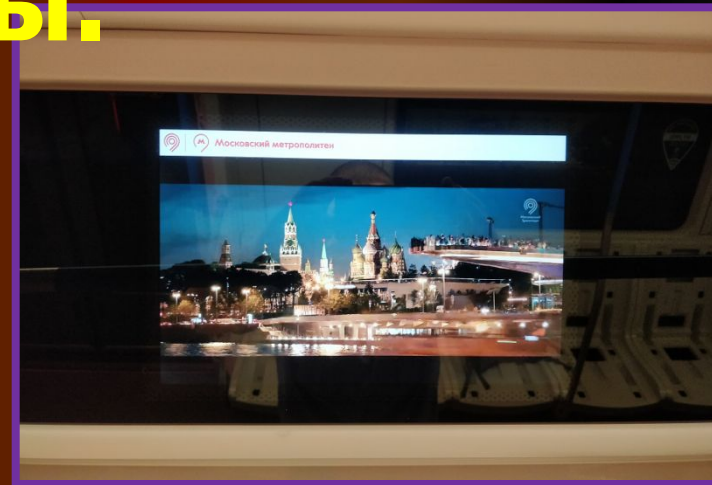
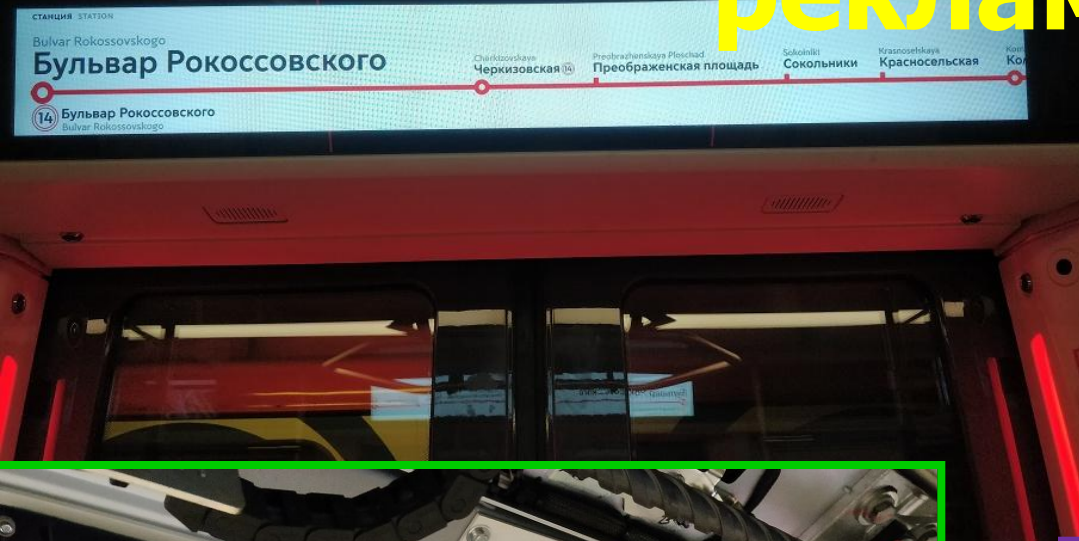

Блок управления нагревом стекол (БУНС).

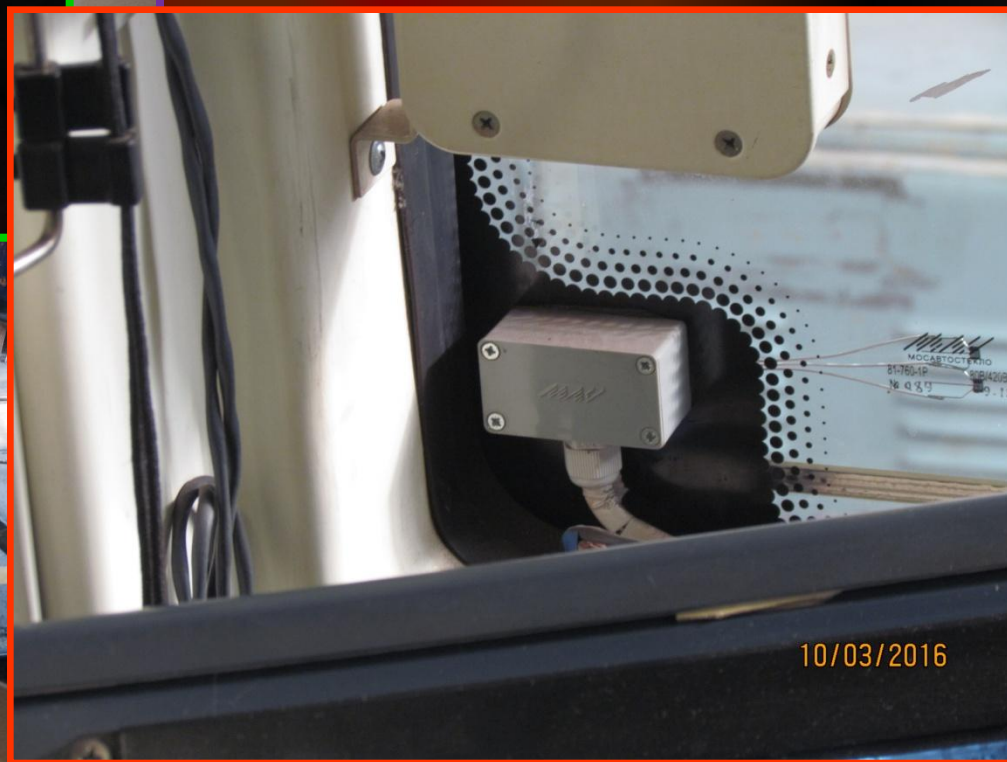

Блок управления дверьми (Буд).

