

ENGINE & TRANSMISSION

图1-1-1



图1-1-1						
序号	零件序列号	零部件编号	名称	名称	数量	备注
No.	PART SERIAL NO.	Part No.	PART NAME	PART NAME	Qty	Rem.
1			高压线卡支架	Bracket, clip, high tension cable	1	BD
2			缸盖	Cylinder head	1	BD
3	01.02.00BD 005GHH368 QA1	1003070	气缸垫总成	Gasket comp., cylinder block	1	BD
4		1003064E	气缸盖罩密封垫	Gasket comp., cylinder head cover	1	BD
5		1000025D	进水管密封垫	Gasket, water inlet pipe	1	BD
6	01.04.00BD 001GHH368 QA1	1000054	排气歧管隔热垫总成	Heat insulator comp., exhaust manifold	1	BD
7		1000035D	分电器座密封垫	Gasket, distributor seat	1	BD
8		1002030D	后端盖密封垫	Gasket, rear end plate	1	BD
9		1000051D	机油泵垫	Gasket, oil pump case	1	BD
10	01.10.00BD 027GHH368 QA1	1000052D	水泵密封垫	Gasket, water pump	1	BD
11		1000029D	前后罩壳密封垫	Gasket, F.R. & R.R house	1	BD

图1-2-1

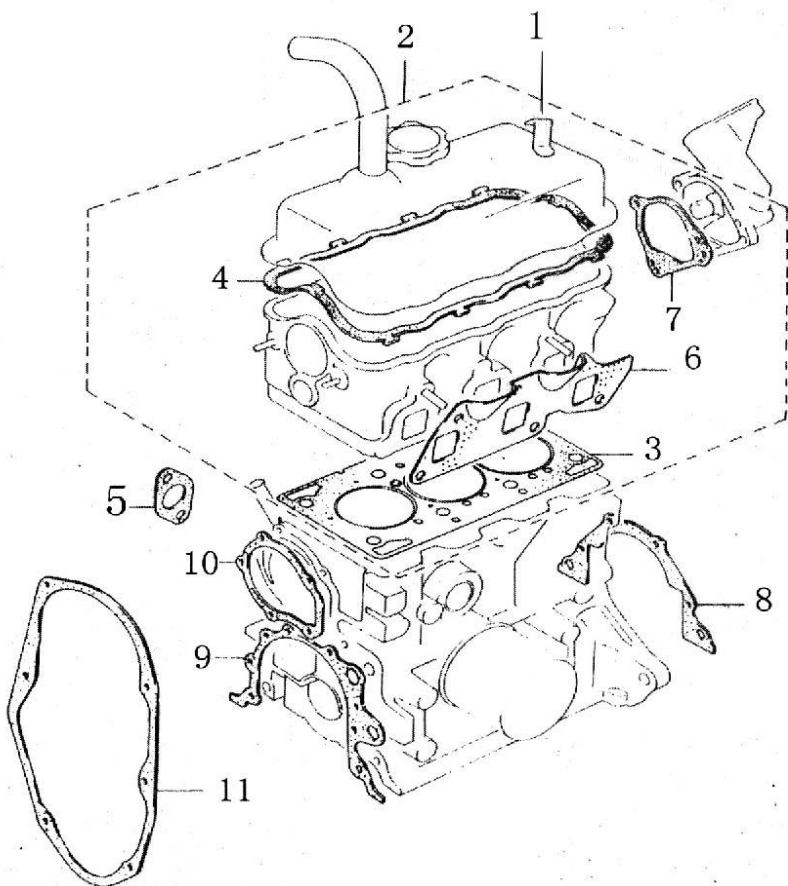

图1-2-1

序号	零件序列号	零部件编号	名称	名称	数量	备注
No.	PART SERIAL NO.	Part No.	PART NAME	PART NAME	Qty	Rem.
1	01.02.00BD001 GHH368QA1	1003010E	气缸盖总成	Cylinder head comp.	1	BD
2			气门导管	Pipe, valve	6	BD
3			堵塞	Plug	6	BD
4	01.02.00BD003 GHH368QA1	1000031D	气缸盖螺栓	Bolt	8	BD
5	01.02.00BD004 GHH368QA1	1000028D	气缸盖定位销	Pin	2	BD
6	01.02.00BD005 GHH368QA1	1003070	气缸垫总成	Gasket comp., cylinder block	1	BD
7	01.02.00BD006 GHH368QA1	1003050E	气缸盖罩总成	Cover comp., cylinder head	1	BD
8	01.02.00BD007 GHH368QA1	1000061D	气缸盖罩螺栓垫圈总成	Bolt & washer, cylinder head cover	4	BD
9		1000059D	气缸盖罩螺栓	Bolt, cylinder head cover	4	BD
10	01.02.00BD008 GHH368QA1	1003064E	气缸盖罩密封垫	Gasket, cylinder head cover	1	BD

图1-2-1

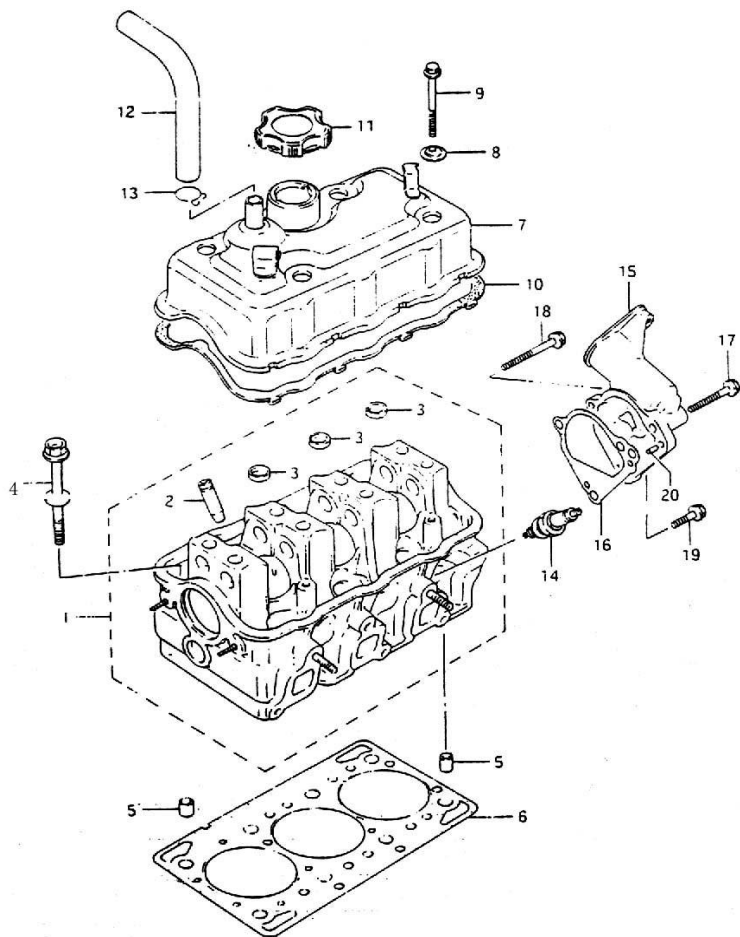

图1-2-1

序号	零件序列号	零部件编号	名称	名称	数量	备注
No.	PART SERIAL NO.	Part No.	PART NAME	PART NAME	Qty	Rem.
11	01.02.00BD009 GHH368QA1	1003052	加油口盖总成	Cover comp., oil filler	1	BD
12			通气软管	Pipe, vent	1	BD
13			卡箍	Snap ring	1	BD
14	12.01.00BD001 G	JB/T6472 —1992	火花塞 F6RTC	Spark plug F6RTC	3	BD
	12.01.7110005 GLJ465Q-1AE N1					7110(LJ465)
15	12.01.00BD002 G	1000038E	分电器座	Seat, distributor	1	BD
16		1000035D	分电器座密封垫	Gasket, distributor seat	1	BD
17	01.07.00TY021 G	1000089D	分电器座带肩螺栓	Bolt W/T flange, distributor seat	1	BD
18	01.07.00TY019 G	1000087D	分电器座带肩长螺栓	Bolt W/T flange, distributor seat	1	BD
19	01.07.00TY020 G	1000171	分电器座紧固带肩螺栓	Fastening (bolt) W/T flange, distributor seat	1	BD
20	01.09.00BD001 GHH368QA1	1000122D	前端定位销	Pin	2	BD

图1-2-4

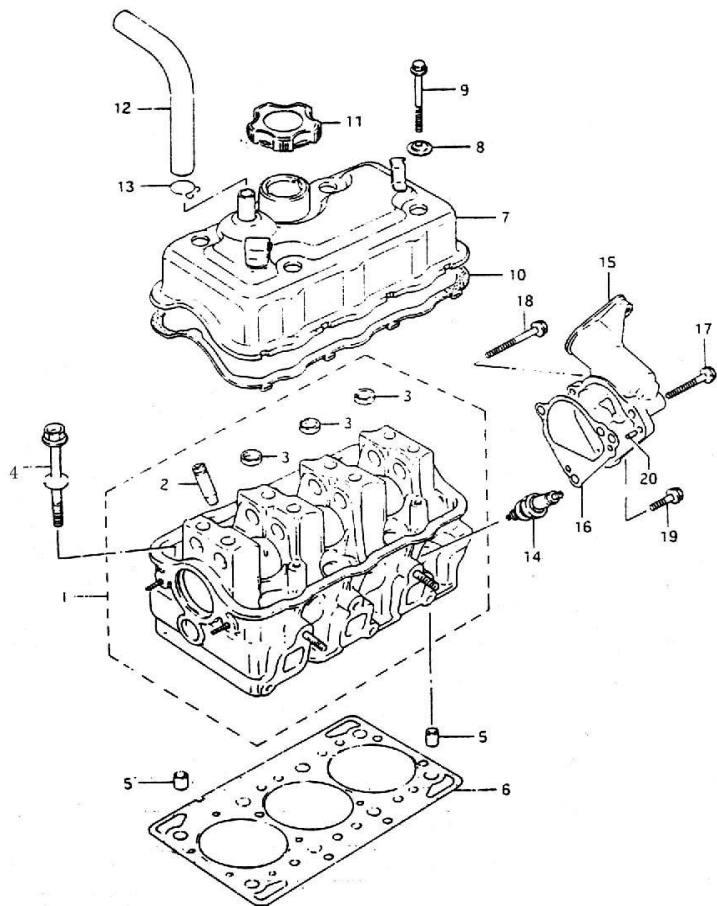

图1-2-4

序号 No.	零件序列号 PART SERIAL NO.	零部件编号 Part No.	名称 PART NAME	名称 PART NAME	数量 Qty	备注 Rem.
1	01.02.7110001 GHH465Q-2E	1003010E	气缸盖总成	Cylinder head comp	1	7110
2	01.02.7110002 GHH465Q-2E	1003070E	气缸垫总成	Cylinder gasket comp	1	7110
3	01.02.7110003 GHH465Q-2E	HH462Q.1 000028D	气缸盖定位销	Cylinder head positioning sleeve	2	7110
4	12.01.7110002 G	JB/T6472- 1992	火花塞总成	Spark plug comp	4	7110
5		GB/T859-1 987	垫圈10	Washer 10	10	7110
6	01.02.7110008 GHH465Q-2E	HH462Q.1 000031D	气缸盖连接螺栓 M10×1.25×87	Bolt M10×1.25×87	8	7110
7		GB/T5787- 1986	螺钉M6×10	Screw M6×10	8	7110
8	01.02.7110004 GHH465Q-2E	1003058E	气缸盖罩组件	House comp., cylinder head	1	7110
9		HH462Q.1 000061D	封严胶圈总成	Seal ring comp	4	7110
10		GB/T5787- 1986	螺钉M6×68	Screw M6×68	4	7110

图1-2-4

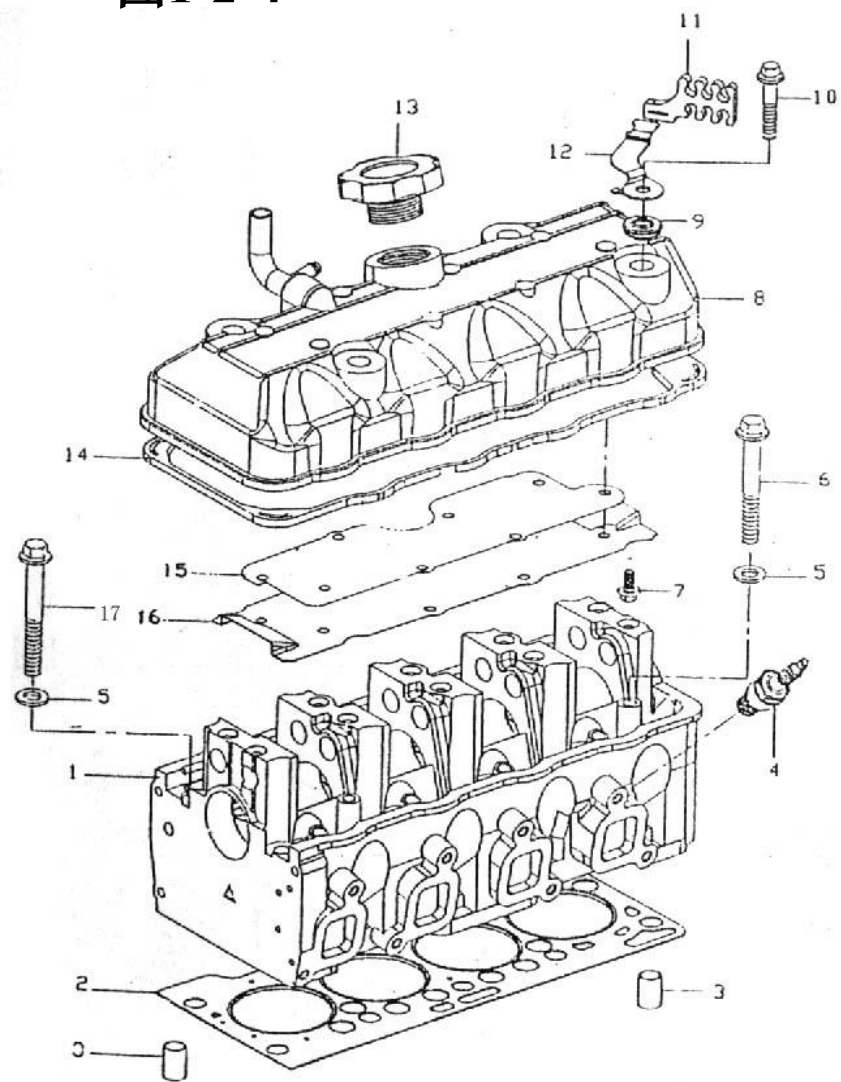

图1-2-4

序号 No.	零件序列号 PART SERIAL NO.	零部件编号 Part No.	名称 PART NAME	名称 PART NAME	数量 Qty	备注 Rem.
11		1000076E	高压阻尼线线卡	Clamp, high tension cable	1	7110
12			高压阻尼线支撑架	Bracket, cable	1	7110
13	01.02.7110005 GHH465Q-2E	HH462Q.1 003052D	加油口盖总成	Fuel filler cap comp	1	7110
14	01.02.7110006 GHH465Q-2E	1003051E	气缸盖罩密封垫	Gasket, cylinder head house seal	1	7110
15	01.02.7110007 GHH465Q-2E		气门室罩隔板垫	Cushion, valve cage distance plate	1	7110
16	01.02.7110010 GHH465Q-2E		气门室罩隔板	Distance plate, valve cage	1	7110
17		GB/T848-1 985	螺钉	Screw	2	7110

图1-3-1

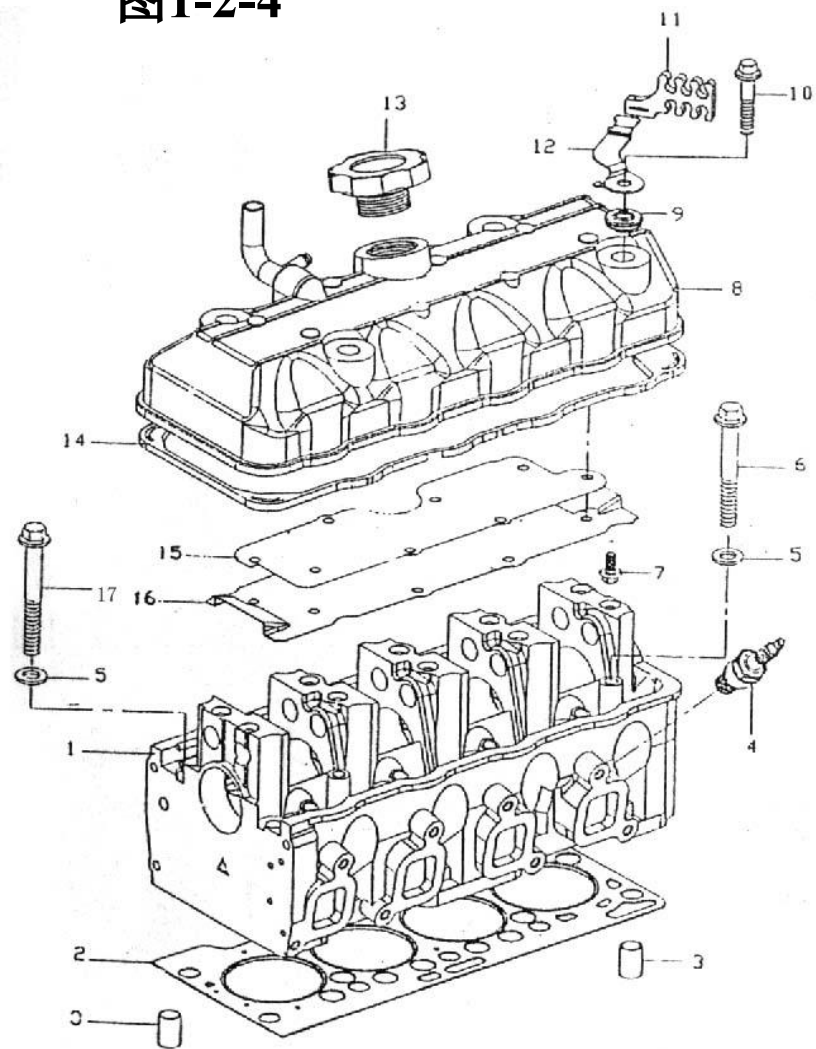

图1-3-1

序号 No.	零件序列号 PART SERIAL NO.	零部件编号 Part No.	名称 PART NAME	名称 PART NAME	数量 Qty	备注 Rem.
1	01.03.00BD001 GHH368QA1	1002011E	曲轴箱总成	Crankshaft case comp.	1	BD
2			碗形堵塞	Bowl-shaped plug	1	BD
3			韧盖(堵盖)	Plug	1	BD
4			锥形螺塞	Threaded cone plug	1	BD
5			锥形螺塞	Threaded cone plug	1	BD
6			锥形螺塞	Threaded cone plug	2	BD
7	01.03.00BD002 GHH368QA1		曲轴盖螺栓	Bolt, crankshaft cover	8	BD
8	01.03.00BD003 GHH368QA1	1000018	油位计导管	Pipe, oil gauge	1	BD
9		1002027D	封水端盖	Cover	1	BD
10		1002028D	封水端盖密封垫	Gasket, cover	1	BD
11			封水端盖螺栓	Bolt, cover	4	BD
12	01.03.00BD004 GHH368QA1	1012031D	连接管	Pipe	1	BD

图1-3-1

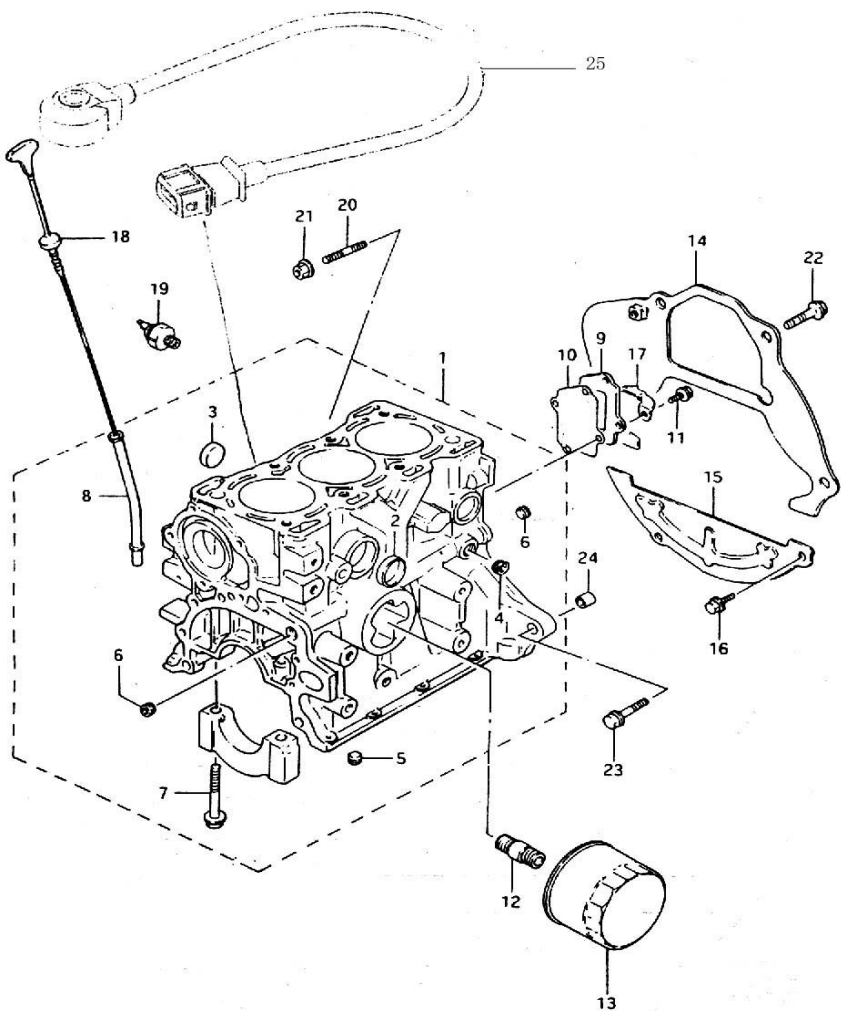

图1-3-1

序号 No.	零件序列号 PART SERIAL NO.	零部件编号 Part No.	名称 PART NAME	名称 PART NAME	数量 Qty	备注 Rem.
13	01.03.00BD005 GHH368QA1	1012010	机油滤清器	Oil filter	1	BD
14	01.03.00BD006 GHH368QA1	1000097	离合器上隔板	Distance plate, clutch, Upper	1	BD
15	01.03.00BD007 GHH368QA1	1000011	变速器壳下隔板	Distance plate comp., clutch, Lower	1	BD
16			离合器隔板螺栓	Bolt, clutch distance plate	2	BD
17		1000026	火花正时支架	Bracket, ignition timing	1	BD
18	01.03.00BD009 GHH368QA1	1002050	油位计总成	Oil level gauge comp.	1	BD
19	01.11.00BD005 GHH368QA1	3810010 D	机油压力报警器总成	Oil pressure warning device	1	BD
20	01.03.00BD008 GHH368QA1		双头螺栓	Stud	1	BD
21		GB/T617 1—1986	螺母 M10×1.25	Nut M10×1.25	1	BD
22		1000167	曲轴箱与变速器连接带肩螺栓	Bolt W/T flange, for connecting the crankshaft and the transmission	1	BD
23		1000163	曲轴箱与变速器连接带肩螺栓	Bolt W/T flange, for connecting the crankshaft and the transmission	2	BD
24		1000071 D	变速箱定位套	Pin, gearbox	2	BD
25	01.11.00BD006 GHH368QA1	3600080 E	爆震传感器	Knock sensor	1	BD

图1-3-4

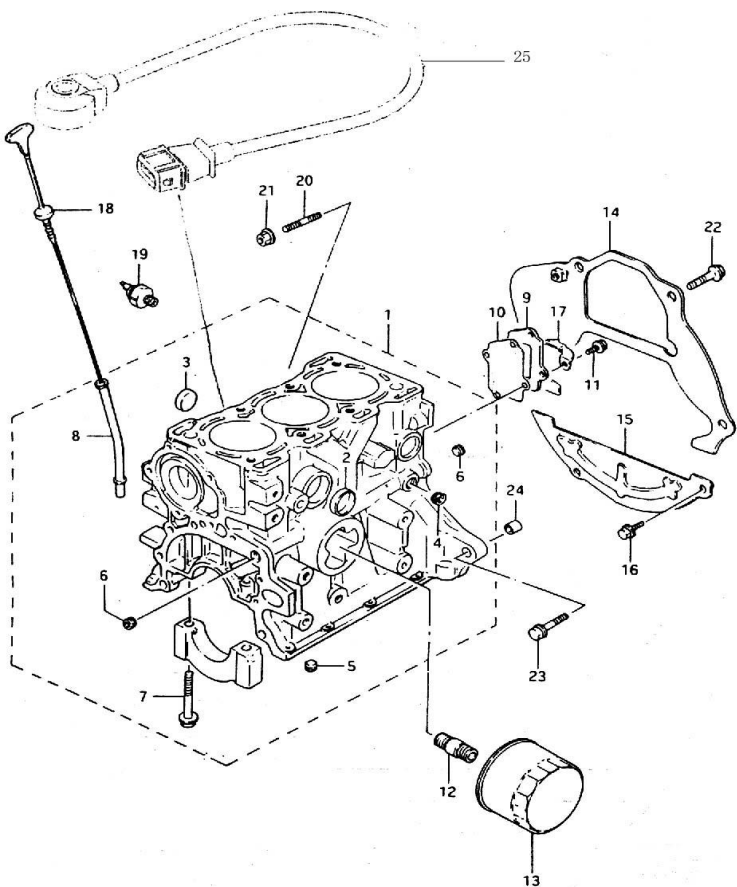

图1-3-4

序号 No.	零件序列号 PART SERIAL NO.	零部件编号 Part No.	名称 PART NAME	名称 PART NAME	数量 Qty	备注 Rem.
1	01.03.7110001 GHH465Q-2E	1002010E	曲轴箱总成	Cylinder body	1	7110
2			螺堵	Threaded plug	4	7110
3	01.03.7110002 GHH465Q-2E	HH462Q.1 000013D	机油滤垫	Cushion, oil filter	1	7110
4	01.03.7110029 GHH465Q-2E	1012032E	机油滤座	Seat, oil filter	1	7110
5	01.11.7110004 GHH465Q-2E	HH462Q.3 810010D	油压传感器 总成	Sensor comp., oil pressure	1	7110
6		GB/T5787- 1986	螺钉M6×25	Screw M6×25	2	7110
7		GB/T5787- 1986	螺钉M6×65	Screw M6×65	1	7110
8	01.03.7110003 GHH465Q-2E	HH465QD. 1012010	机油滤清器	Oil filter comp.	1	7110
9	01.03.7110005 GHH465Q-2E	HH462Q.1 002016D	油滤接管嘴	Nozzle, oil filter pipe	1	7110
10			胶圈	Rubber ring	1	7110

图1-3-4

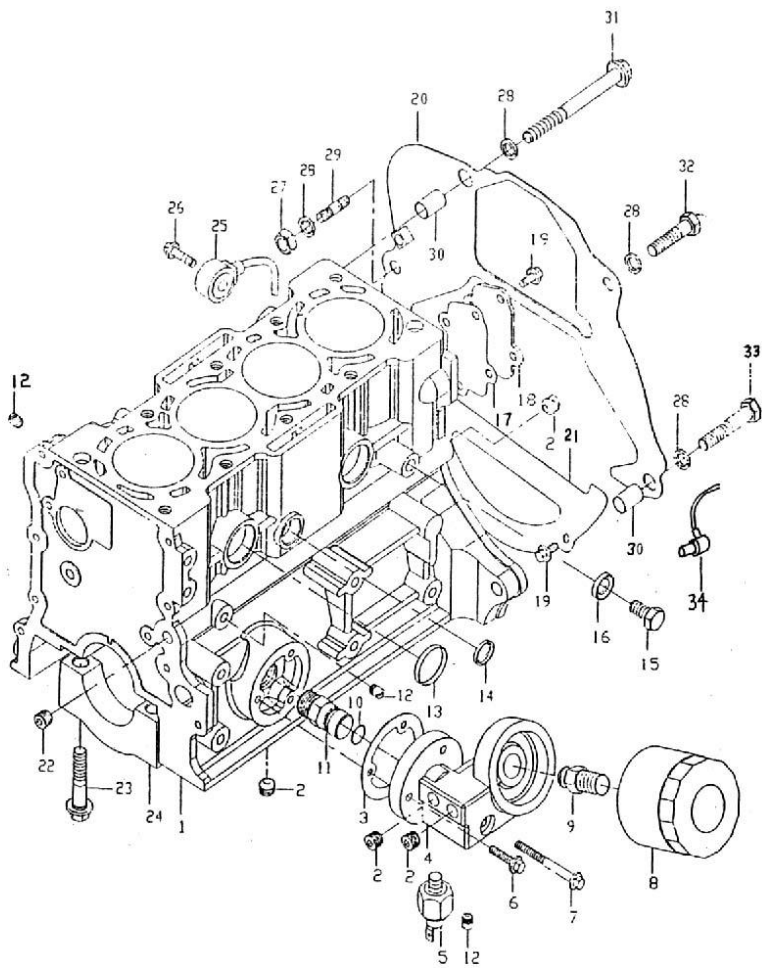

图1-3-4

序号 No.	零件序列号 PART SERIAL NO.	零部件编号 Part No.	名称 PART NAME	名称 PART NAME	数量 Qty	备注 Rem.
11			油滤接管嘴	Nozzle, oil filter pipe	1	7110
12			螺堵	Threaded plug	3	7110
13			碗形塞片	U-shaped insert shim	4	7110
14			碗形塞片	U-shaped insert shim	2	7110
15			水套螺堵	Threaded plug, jacket	1	7110
16			水套螺堵垫圈总成	Washer comp., jacket threaded plug	1	7110
17		HH462Q.1 002028D	水套盖板垫	Cushion, jacket cover	1	7110
18		HH462Q.1 002027D	水套盖板	Cover, jacket	1	7110
19		GB/T818-1 985	螺钉 M6×10	Screw M6×10	4	7110
20	01.03.7110006G HH465Q-2E	HH368Q-1 E.1000097 E	上隔板	Distance plate comp., upper	1	7110

图1-3-4

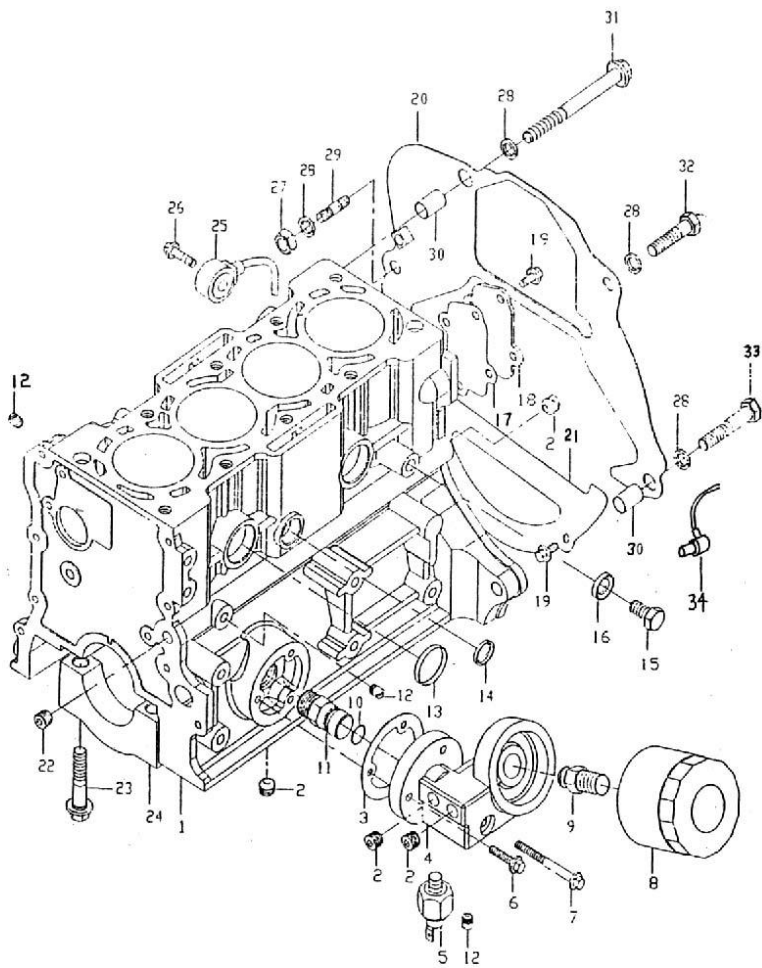

图1-3-4

序号 No.	零件序列号 PART SERIAL NO.	零部件编号 Part No.	名称 PART NAME	名称 PART NAME	数量 Qty.	备注 Rem.
21	01.03.7110007 GHH465Q-2E	HH368Q-1E. 1000110E	下隔板	Distance plate, lower	1	7110
22			螺堵	Threaded plug	1	7110
23			螺钉	Screw	10	7110
24--1	01.03.7110010 GHH465Q-2E		1# 曲轴主 轴承盖	Cap, crankshaft 1# main bearing	1	7110
24--2	01.03.7110011 GHH465Q-2E		2# 曲轴主 轴承盖	Cap, crankshaft 2# main bearing	1	7110
24--3	01.03.7110012 GHH465Q-2E		3# 曲轴主 轴承盖	Cap, crankshaft 3# main bearing	1	7110
24--4	01.03.7110013 GHH465Q-2E		4# 曲轴主 轴承盖	Cap, crankshaft 4# main bearing	1	7110
24--5	01.03.7110014 GHH465Q-2E		5# 曲轴主 轴承盖	Cap, crankshaft 5# main bearing	1	7110
27			螺母	Nut	1	7110
28			弹簧垫圈	Spring washer	4	7110
29		HH368Q-1E. 1000167E	双头螺柱	Stud	1	7110
30		HH462Q.100 0071D	定位套	Positioning sleeve	2	7110
31			螺钉	Screw	1	7110
32		HH368Q-1E. 1000169E	螺栓	Bolt	1	7110
33		HH368Q-1E. 1000169E	螺栓	Bolt	1	7110
34		3600110E	曲轴位置 传感器	Sensor, crankshaft position		7110

图1-4-1

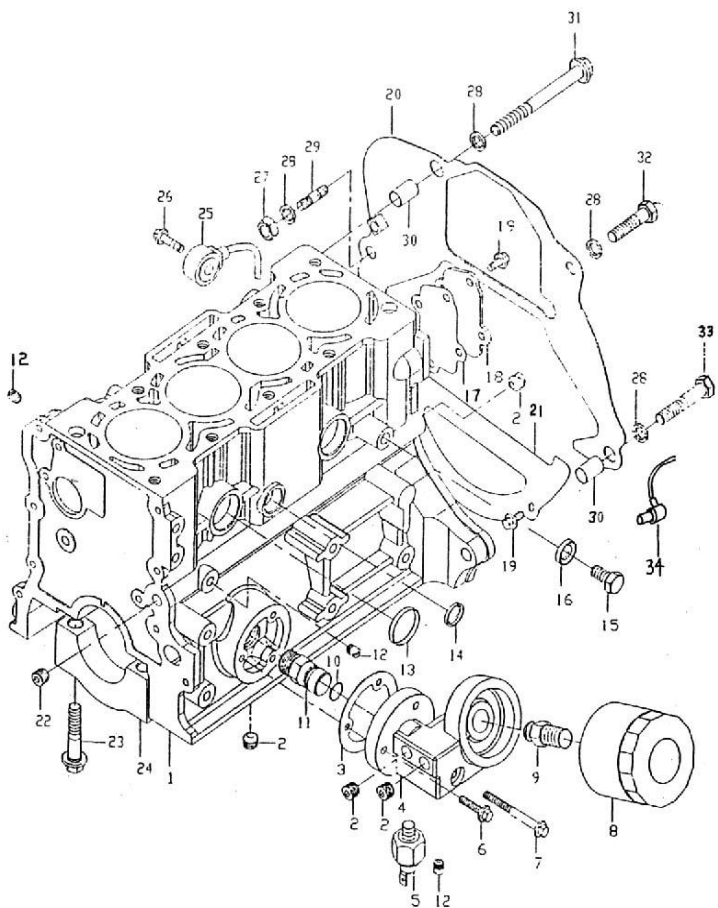

图1-4-1

序号 No.	零件序列号 PART SERIAL NO.	零部件编号 Part No.	名称 PART NAME	名称 PART NAME	数量 Qty	备注 Rem.
1	01.05.00BD017 GHH368QA1	1009010	油底壳总成	Oil pan comp	1	BD
2			紧固螺栓	Fastening bolt	14	BD
3			油底壳锁紧垫圈	Washer, oil sump	14	BD
4			螺柱	Stud	2	BD
5			油底壳锁紧垫圈	Washer, oil sump	2	BD
6			油底壳螺母	Nut, oil sump	2	BD
7	01.05.00BD019 GHH368QA1		放油螺塞	Threaded plug, oil drainage	1	BD
8			放油螺塞垫圈	Washer, threaded plug	1	BD
9	01.05.00BD022 GHH368QA1	1010010	机油集滤器总成	Oil collector comp.	1	BD
10			O形密封圈	O seal	1	BD
11			螺栓	Bolt	2	BD
12			弹垫	Washer	2	BD

图1-4-3

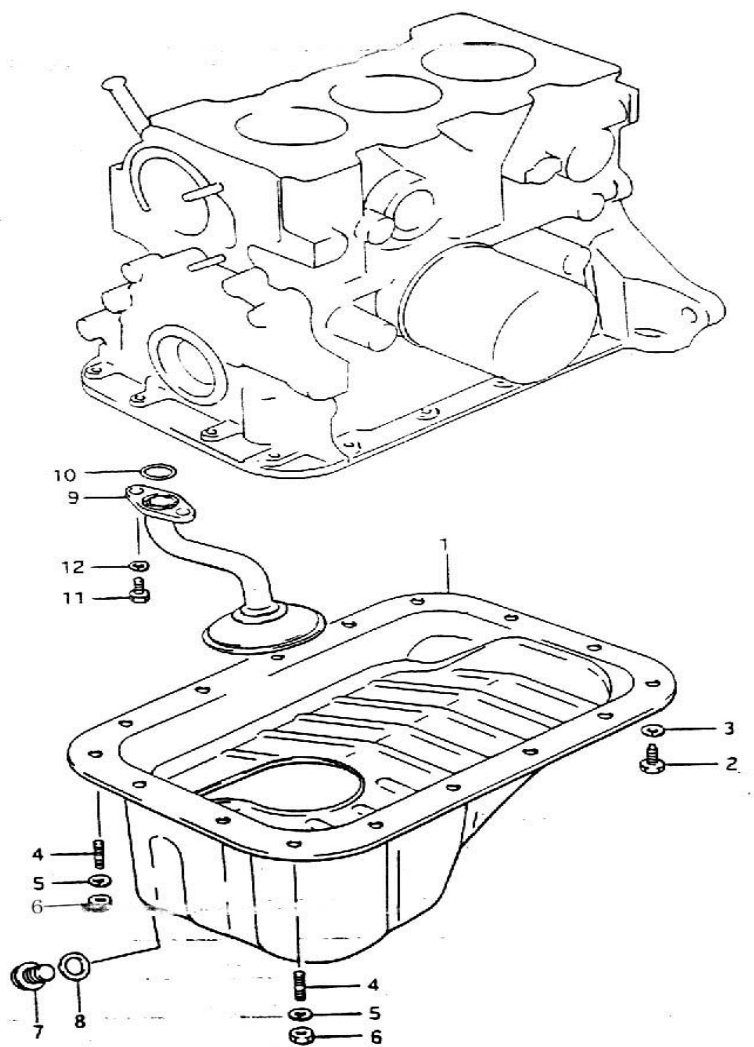

图1-4-3

序号 No.	零件序列号 PART SERIAL NO.	零部件编号 Part No.	名称 PART NAME	名称 PART NAME	数量 Qty.	备注 Rem.
1	01.03.7110016GH H465Q-2E	1009010E	油底壳总成	oil sump comp	1	7110
2	01.03.7110017GH H465Q-2E	1000064E	油底壳密封垫	Gasket, oil sump	1	7110
3	01.03.7110018GH H465Q-2E 01.07.00TY017G 01.03.7110031G	GB/T5783-1986	螺钉总成 M6×20	Screw comp. M6×20	14	7110
4			放油螺塞	Threaded drainage plug	1	7110
5	01.03.7110032G		垫圈	Washer	1	7110
6			胶圈	Rubber ring	1	7110
7	01.03.7110019GH H465Q-2E	1010010E	机油集滤器总成	Oil collector comp.	1	7110
8		GB/T5783-1986	螺钉M6×25	Screw M6×25	2	7110
9		GB/T900-1988	双头螺柱	Stud	4	7110
10			弹簧垫圈	Spring washer	4	7110
11			螺母	Nut	4	7110
12			线束卡总成	Mini hook comp.	1	7110

图1-5-1

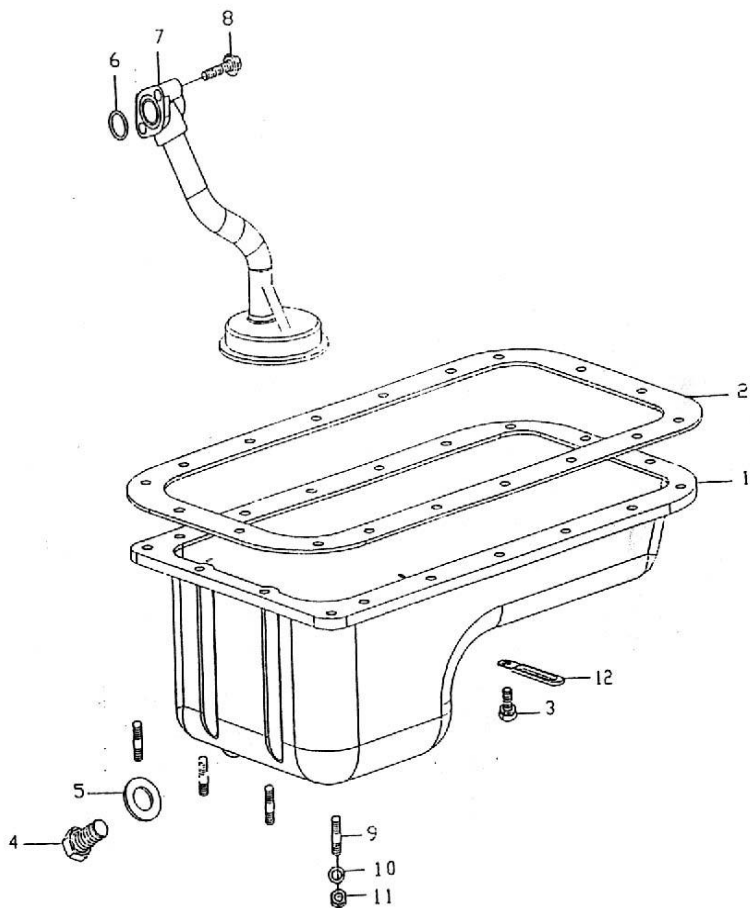

图1-5-1

序号 No.	零件序列号 PART SERIAL NO.	零部件编号 Part No.	名称 PART NAME	名称 PART NAME	数量 Qty	备注 Rem.
1	01.05.00BD001 GHH368QA1	1004020	活塞环总成	Piston ring assy.	9	BD
2	01.05.00BD002 GHH368QA1	1004028	活塞	Piston	3	BD
3	01.05.00BD003 GHH368QA1	1004021	活塞销	Piston pin	3	BD
4	01.05.00BD004 GHH368QA1	1004022 D	活塞销卡 环	Lock ring, piston pin	6	BD
5	01.05.00BD005 GHH368QA1	1004011 D	连杆总成	Connecting rod comp.	3	BD
6		1004012	连杆螺母	Nut, connecting rod	6	BD
7	01.05.00BD006 GHH368QA1	1004041 D	连杆轴瓦	Bearing shell, connecting rod	6	BD
8	01.05.00BD007 GHH368QA1	1005022	曲轴	Crankshaft	1	BD
9	01.05.00BD008 GHH368QA1	1005023	曲轴轴瓦	Bearing shell, crankshaft	8	BD
10	01.05.00BD009 GHH368QA1	1000047 D	曲轴止推 片	Thrust bearing shell, crankshaft	2	BD
11	01.05.00BD010 GHH368QA1	1011016 D	曲轴前油 封总成	Oil seal, crankshaft, F.R.	1	BD
12		1000024	正时皮带 档片	Plate, timing belt	1	BD
13	01.05.00BD011 GHH368QA1	1000048	曲轴正时 皮带轮	Timing pulley, crankshaft	1	BD

图1-5-1

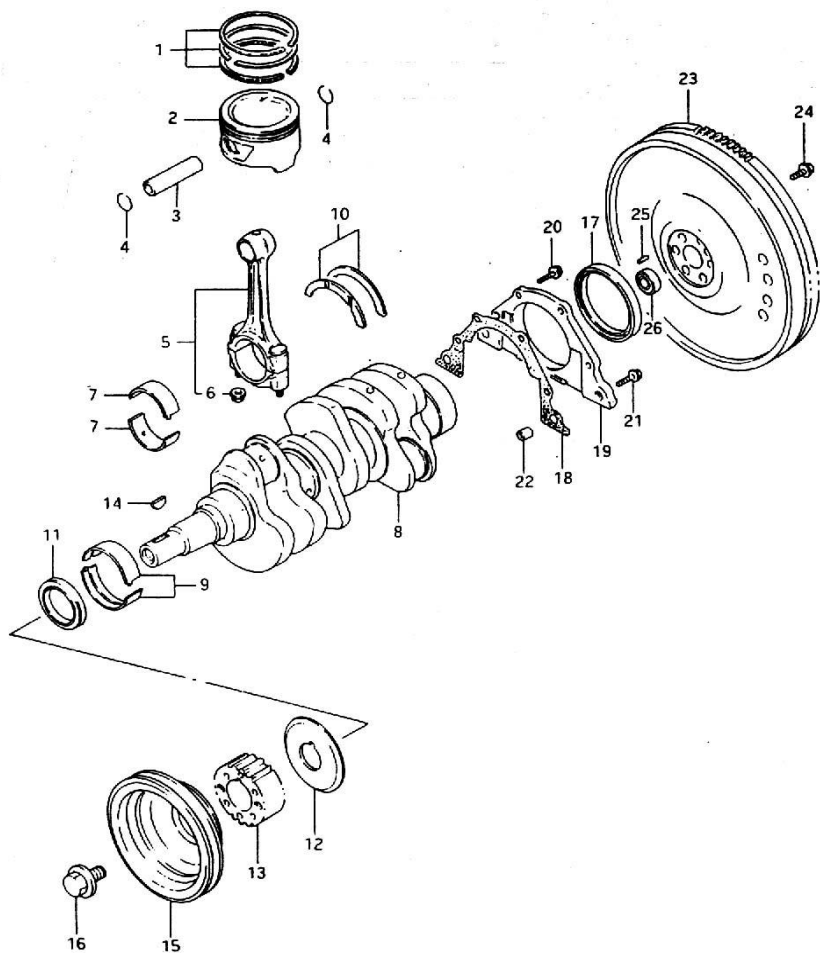

图1-5-1

序号 No.	零件序列号 PART SERIAL NO.	零部件编号 Part No.	名称 PART NAME	名称 PART NAME	数量 Qty	备注 Rem.
14		GB/T1099—1979	半圆键5×19	Semicircle pin 5×19	1	BD
15	01.05.00BD012 GHH368QA1	1000049	主动三角皮 带轮	V-belt pulley, driving	1	BD
16		GB/T5786—1986	六角头螺栓 M12×1.25× 25	Bolt M12×1.25×25	1	BD
17	01.05.00BD013 GHH368QA1	1020022D	曲轴后油封 总成	Oil seal, crankshaft, R.R.	1	BD
18		1002030D	后端盖密封 垫	Gasket, rear end plate	1	BD
19	01.05.00BD027 GHH368QA1	1002020D	曲轴后端盖	Rear end plate, crankshaft	1	BD
20			螺栓	Bolt	4	BD
21			螺栓	Bolt	2	BD
22		1000014	定位套(曲 轴后油封端 盖用)	Pin, rear end plate, oil pump crankshaft	2	BD
23	01.05.00BD014 GHH368QA1	1005011	飞轮齿圈总 成	Toothed ring comp., flying wheel	1	BD
24		1005014D	飞轮螺栓	Bolt, wheel	6	BD
25		1000122	定位销	Pin	1	BD
26			轴承	Bearing	1	BD

图1-5-4

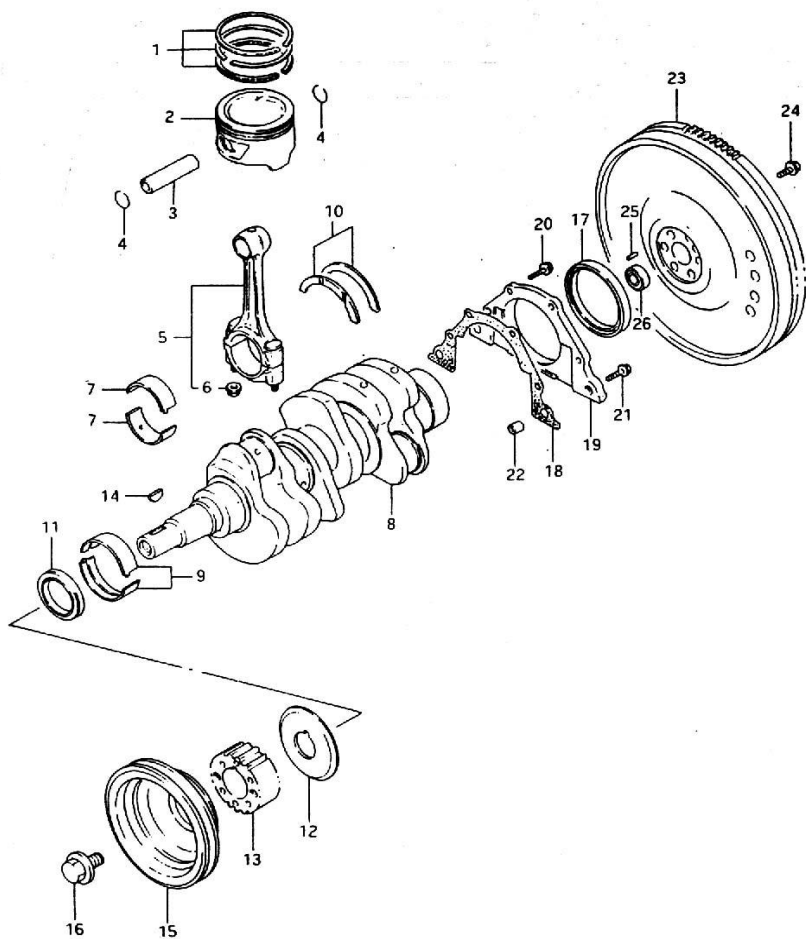

图1-5-4

序号 No.	零件序列号 PART SERIAL NO.	零部件编号 Part No.	名称 PART NAME	名称 PART NAME	数量 Qty.	备注 Rem.
1-1	01.05.7110001GHH465Q-2E	HH465QA.1 004027	第一道活 塞气环	Gas tight ring 1#, piston	4	7110
1-2	01.05.7110001GHH465Q-2E	HH465QA.1 004026	第二道活 塞气环	Gas tight ring 2#, piston	4	7110
1-3	01.05.7110001GHH465Q-2E	HH465QA.1 004024	活塞油环 总成	Oil ring comp., piston	4	7110
2	01.05.7110002GHH465Q-2E	HH465QA.1 004028	活塞	Piston	4	7110
3	01.05.7110003GHH465Q-2E	HH368Q.10 04021	活塞销	Piston pin	4	7110
4	01.05.7110004GHH465Q-2E	HH462Q.10 04022D	活塞销卡 环	Snap ring, piston pin	8	7110
5	01.05.7110005GHH465Q-2E	HH465QF.1 004017	连杆总成	Connecting rod comp.	4	7110
6	01.05.7110006GHH465Q-2E 01.05.7110007GHH465Q-2E 01.05.7110008GHH465Q-2E	HH462Q.10 04014D	连杆轴瓦	Bearing shell, connecting rod	8	7110
7	01.05.7110009GHH465Q-2E	1005022E	曲轴	Crankshaft	1	7110
8		GB/T5786- 1986	固定螺钉 M12×1.25 ×25	Fixed screw M12×1.25×25	1	7110
9	01.05.7110010GHH465Q-2E		曲轴皮带 轮	Pulley, crankshaft belt	1	7110
10	01.05.7110011GHH465Q-2E	HH462Q.10 11016D	曲轴前油 封总成	Oil seal cup comp., crankshaft, F. R.	1	7110
11	01.05.7110012GHH465Q-2E 01.05.7110001GLJ465Q-1ANE 1		主动正时 链轮	Driving sprocket wheel, timing	1	7110

图1-5-4

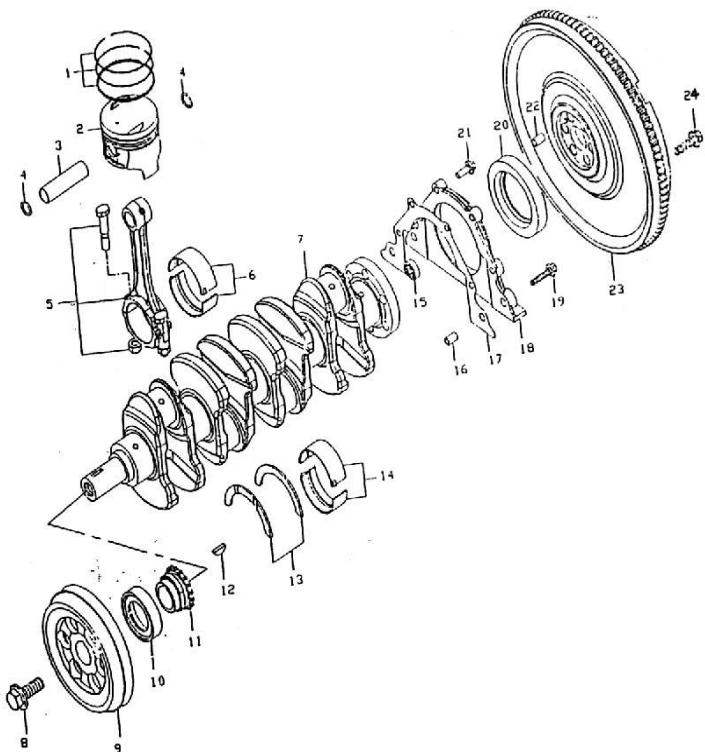

图1-5-4

序号 No.	零件序列号 PART SERIAL NO.	零部件编号 Part No.	名称 PART NAME	名称 PART NAME	数量 Qty.	备注 Rem.
12		GB/T1099-1979	半圆键5×19	Semi-circle key 5×19	1	7110
13	01.05.7110013 GHH465Q-2E	HH462Q.1 000047D	曲轴止推片	Thrust plate, crankshaft	2	7110
14	01.05.7110014 GHH465Q-2E 01.05.7110015 GHH465Q-2E 01.05.7110016 GHH465Q-2E	HH462Q.1 002021D	主轴瓦	Main bearing shell	10	7110
15			轴承	Bearing	1	7110
16			定位套	Positioning sleeve	2	7110
17			垫片	Washer	1	7110
18	01.03.7110009 GHH465Q-2E	HH462Q.1 002030D	曲轴后端盖密封垫	gasket, crankshaft end plate seal	1	7110
19		HH368Q-1 E.1000081 E	螺钉	Screw	2	7110
20	01.05.7110017 GHH465Q-2E	HH462Q.1 002022D	曲轴后油封总成	Oil seal cup comp., crankshaft, R. R.	1	7110
21			螺钉	Screw	4	7110
22			圆柱滚子	Cylinder roller	1	7110
23	01.05.7110018 GHH465Q-2E	1005011E	飞轮及齿圈总成	Flywheel & toothed ring assy.	1	7110
24		HH462Q.1 005014D	飞轮螺栓	Screw, flywheel	6	7110

图1-6-1

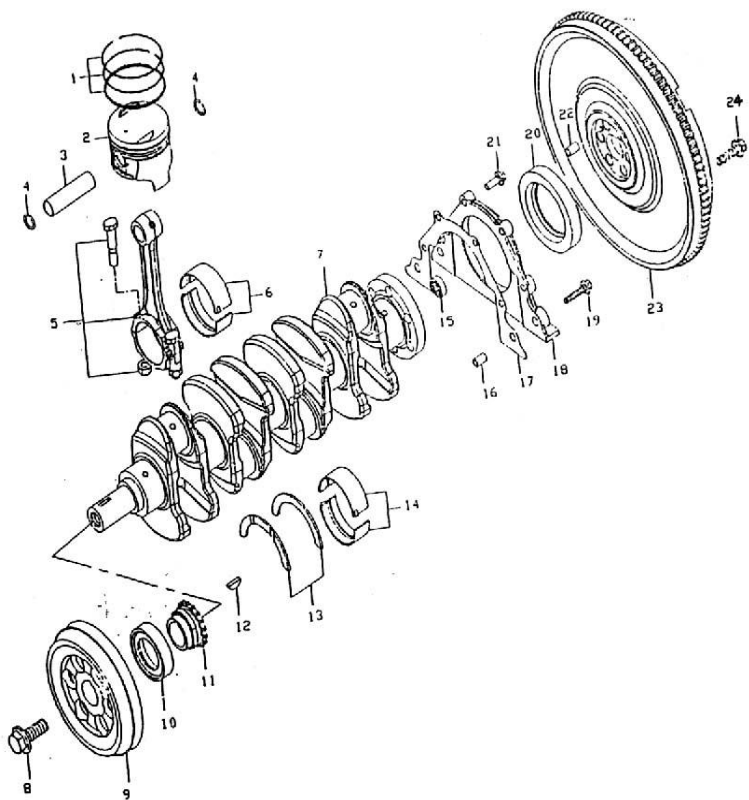

图1-6-1

序号	零件序列号	零部件编号	名称	名称	数量	备注
No.	PART SERIAL NO.	Part No.	PART NAME	PART NAME	Qty	Rem.
1		1000124D	凸轮轴前油封总成	Oil seal comp., camshaft, F.R.	1	BD
2	01.06.00B D002GHH 368QA1	1006010E	凸轮轴总成	Cam shaft comp.	1	BD
3	01.06.00B D003GHH 368QA1	1000129D	凸轮轴止推板	Thrust plate, cam shaft	1	BD
4		GB/T819—1985	螺钉M6×12	Screw M6×12	2	BD
5	01.06.00B D004GHH 368QA1	1007045	摇臂轴	Shaft, rock arm	2	BD
6			摇臂轴螺钉M6×16	Screw M6×16, rock arm shaft	8	BD
7	01.06.00B D005GHH 368QA1	1007026D	摇臂	Rock arm	6	BD
8		1007035D	摇臂轴弹簧	Spring, rock arm shaft	6	BD
9	01.06.00B D006GHH 368QA1	1007033D	进气门	Valve, air intake	3	BD
10	01.06.00B D007GHH 368QA1	1007032D	排气门	Exhaust valve	3	BD

图1-6-1

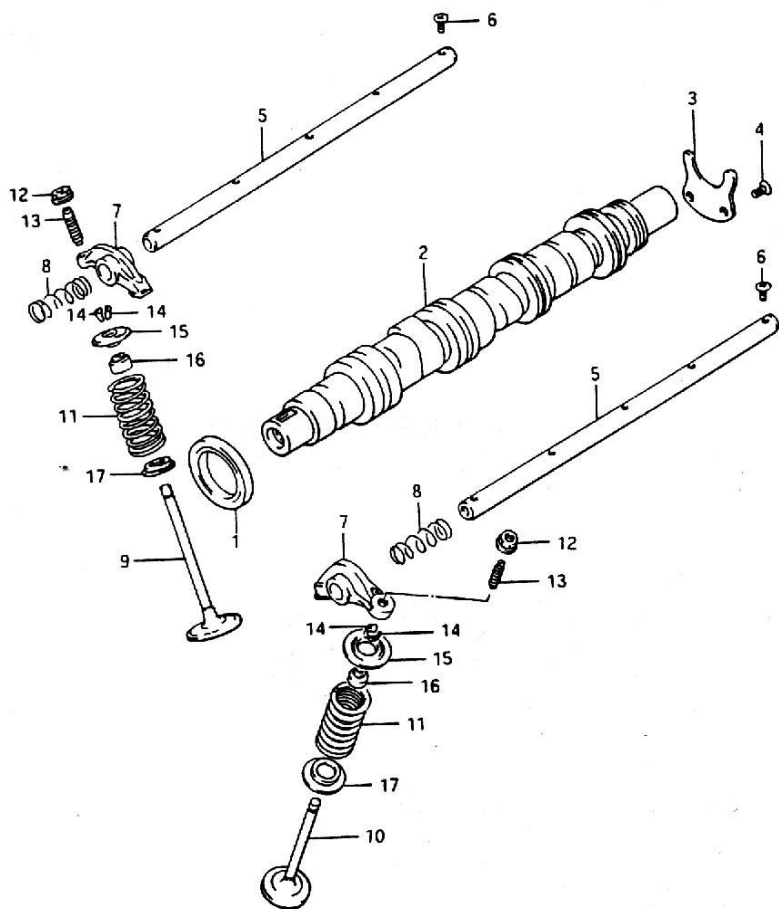

图1-6-1						
序号	零件序列号	零部件编号	名称	名称	数量	备注
No.	PART SERIAL NO.	Part No.	PART NAME	PART NAME	Qty	Rem.
11	01.06.00B D008GHH 368QA1	1007030D	气门弹簧	Spring, valve	6	BD
12	01.06.00B D011GHH 368QA1	1007046D	气门摇臂 调整螺母	Adjustment nut, rock arm, valve	6	BD
13	01.06.00B D012GHH 368QA1	1007027D	摇臂调整 螺钉	Adjustment nut, rock arm	6	BD
14	01.06.00B D013GHH 368QA1	1007028D	气门锥形 锁块	Cone locking block, valve	12	BD
15	01.06.00B D009GHH 368QA1	1007029D	气门弹簧 座	Seat, valve spring	6	BD
16	01.06.00B D014GHH 368QA1	1007022D	气门油封 总成	Oil seal comp., valve	6	BD
17	01.06.00B D010GHH 368QA1	1007021D	气门弹簧 底座	Bottom seat, valve spring	6	BD

图1-6-4

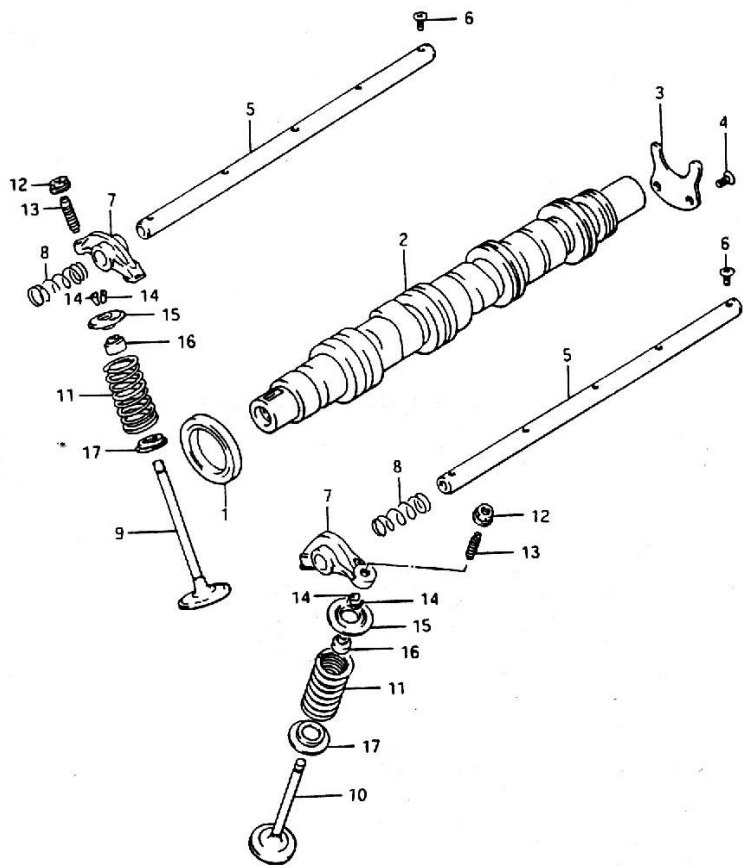

图1-6-4

序号 No.	零件序列号 PART SERIAL NO.	零部件编号 Part No.	名称 PART NAME	名称 PART NAME	数量 Qty	备注 Rem.
1		GB/T5786-1986	固定螺钉 M12×1.25×25	Fixed screw M12×1.25×25	1	7110
2	01.09.7110001 GHH465Q-2E	1000101E	凸轮轴正时链轮	Timing sprocket wheel, camshaft	1	7110
3		HH368Q-1E .1000192E	圆柱销	Cylinder pin	1	7110
4	01.06.7110001 GHH465Q-2E	1006013E	凸轮轴	Cam shaft	1	7110
5	01.06.7110002 GHH465Q-2E	HH462Q.10 00129D	凸轮轴止推板	Thrust plate, camshaft	1	7110
6			一字槽沉头螺钉	Slotted-head screw	2	7110
7	01.06.7110003 GHH465Q-2E	HH462Q.10 07032D1 (D2)	排气门	Exhaust valve	4	7110
8	01.06.7110004 GHH465Q-2E	HH462Q.10 07033D1 (D2)	进气门	Intake valve	4	7110
9	01.06.7110005 GHH465Q-2E	HH462Q.10 07021D	气门弹簧底座	Bottom seat, valve spring	8	7110
10	01.06.7110006 GHH465Q-2E	HH462Q.10 07022D	油封总成	Oil seal comp.	8	7110

图1-6-4

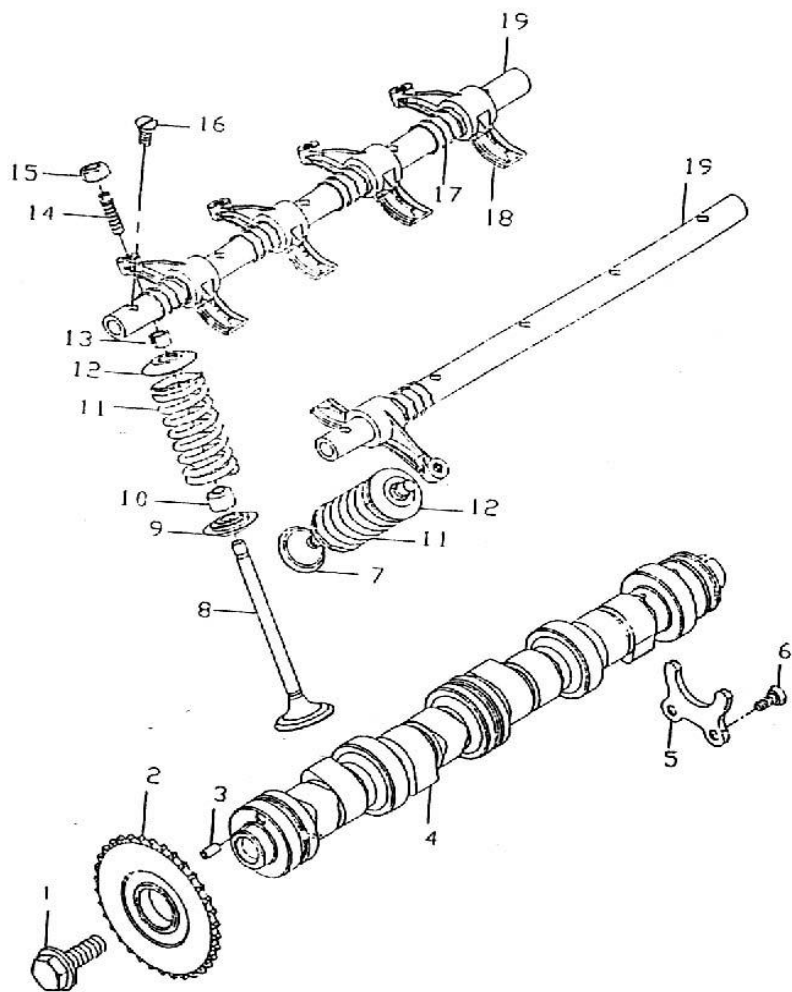

图1-6-4

序号	零件序列号	零部件编号	名称	名称	数量	备注
No.	PART SERIAL NO.	Part No.	PART NAME	PART NAME	Qty	Rem.
11	01.06.7110007 GHH465Q-2E	HH462Q.1 007030D	气门弹簧	Valve spring	8	7110
12	01.06.7110008 GHH465Q-2E	HH462Q.1 007029D	气门弹簧座	Seat, valve spring	8	7110
13	01.06.7110009 GHH465Q-2E	HH462Q.1 007028D	气门锥形锁块	Cone locking block, valve	16	7110
14	01.06.7110010 GHH465Q-2E	HH462Q.1 007027D	气门摇臂调整螺钉	Adjustment screw, valve rock arm	8	7110
15	01.06.7110011 GHH465Q-2E	HH462Q.1 007046D	调整螺母	Adjustment nut	8	7110
16		GB/T819-1 985	一字槽沉头螺钉	Slotted head screw	10	7110
17	01.06.7110012 GHH465Q-2E	HH462Q.1 007035D	气门摇臂轴弹簧	Spring, valve rock arm shaft	8	7110
18	01.06.7110013 GHH465Q-2E	HH462Q.1 007026D	气门摇臂	Rock arm, valve	8	7110
19	01.06.7110014 GHH465Q-2E	HH462Q.1 007045D	气门摇臂轴总成	Valve rock arm shaft comp.	2	7110

图1-7-1

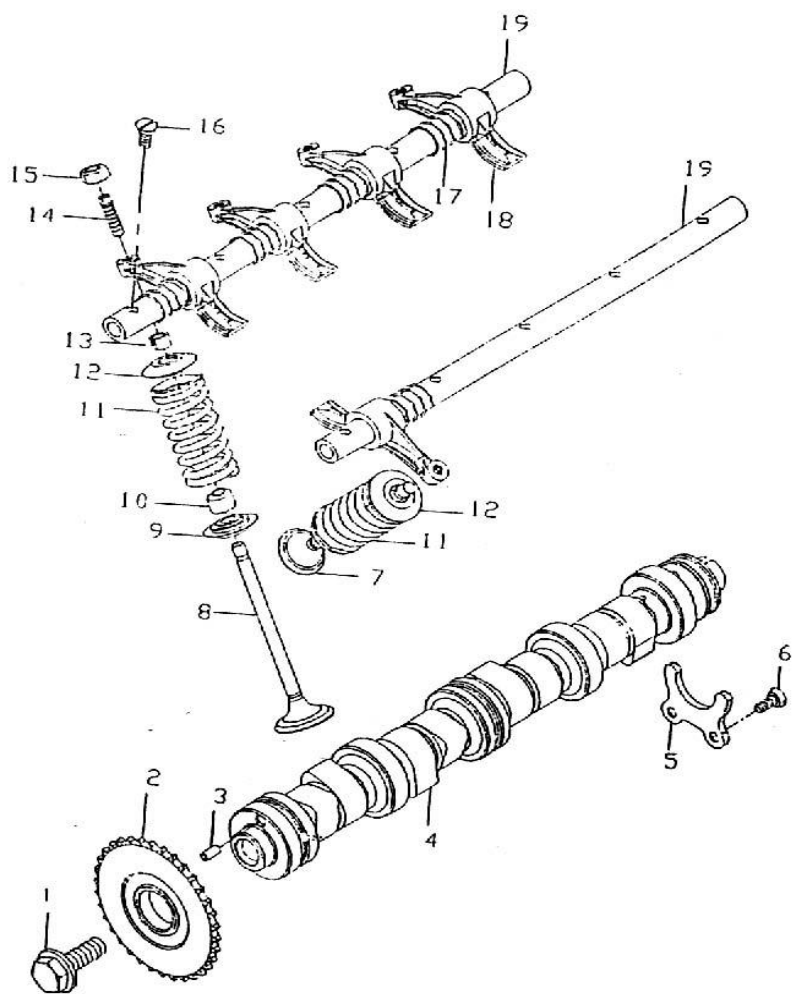

图1-7-1

序号	零件序列号	零部件编号	名称	名称	数量	备注
No.	PART SERIAL NO.	Part No.	PART NAME	PART NAME	Qty.	Rem.
1	01.09.00BD 011GHH368 QA1	1022015	后罩壳总成	Rear shroud comp.	1	BD
2		1022014D	后罩壳橡胶圆垫圈	Rubber washer	2	BD
3		1022012D	后罩壳橡胶垫圈	Rubber washer	2	BD
4		1022013D	衬套	Sleeve	4	BD
5		GB/T97.1 —1985	垫圈6	Washer 6	2	BD
6			螺栓	Bolt	1	BD
7		1000164	后罩壳总成紧固双头螺栓	Fastening stud, rear shroud comp.	2	BD
8		1000019D	发电机支架垫圈	Washer, generator bracket	2	BD
9		GB/T6170 —1986	螺母M6	Nut M6	2	BD
10		1022019D	海绵胶垫	Cushion, sponge	1	BD

图1-7-1

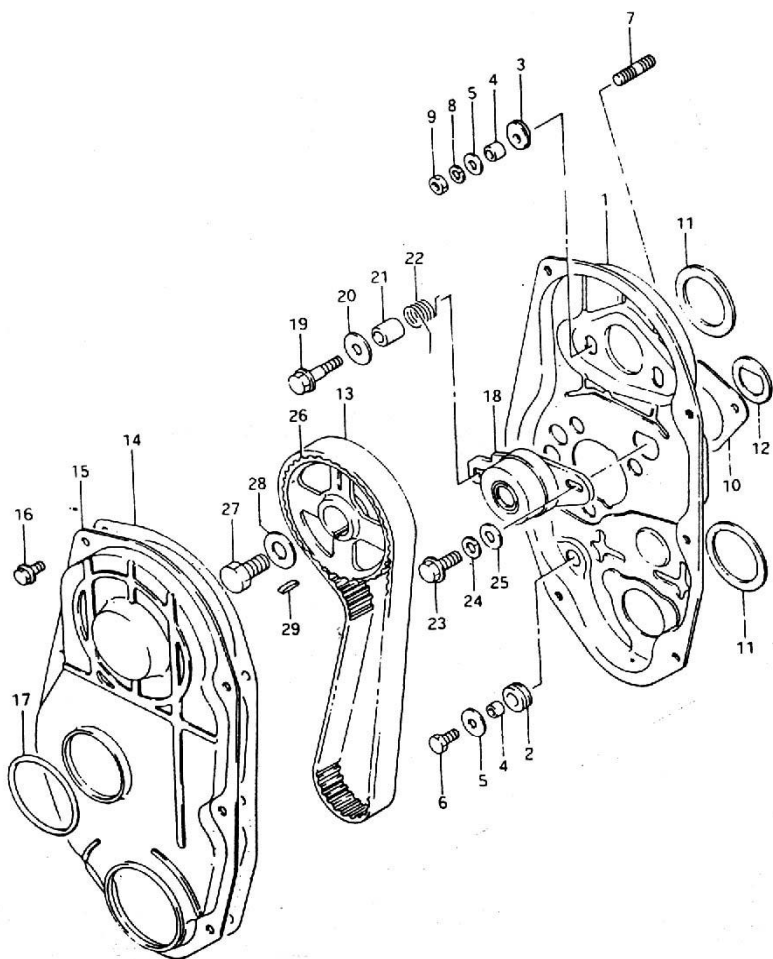

图1-7-1

序号 No.	零件序列号 PART SERIAL NO.	零部件编号 Part No.	名称 PART NAME	名称 PART NAME	数量 Qty	备注 Rem.
11		1022020D	海绵胶园垫圈	Washer, sponge	2	BD
12		1022018D	海绵胶垫圈	Washer, sponge	1	BD
13	01.09.00BD002 GHH368QA1	1000053	正时皮带	Timing belt	1	BD
14		1000029D	前后罩壳橡胶密封垫	Gasket, F.R.& R.R. shroud	1	BD
15	01.09.00BD010 GHH368QA1	1023011D	前罩壳总成	Front shield assy.	1	BD
16			螺栓	Bolt	6	BD
17		1023013D	前罩壳档圈	Backing-up ring, front shroud	1	BD
18	01.09.00BD004 GHH368QA1	1021010D	张紧轮总成	Tension pulley comp.	1	BD
19	01.09.00BD005 GHH368QA1	1000088D	张紧轮总成带肩螺栓	Bolt w/t flange, tension pulley comp.	1	BD
20		GB/T848— 1985	垫圈8	Washer 8	1	BD

图1-7-1

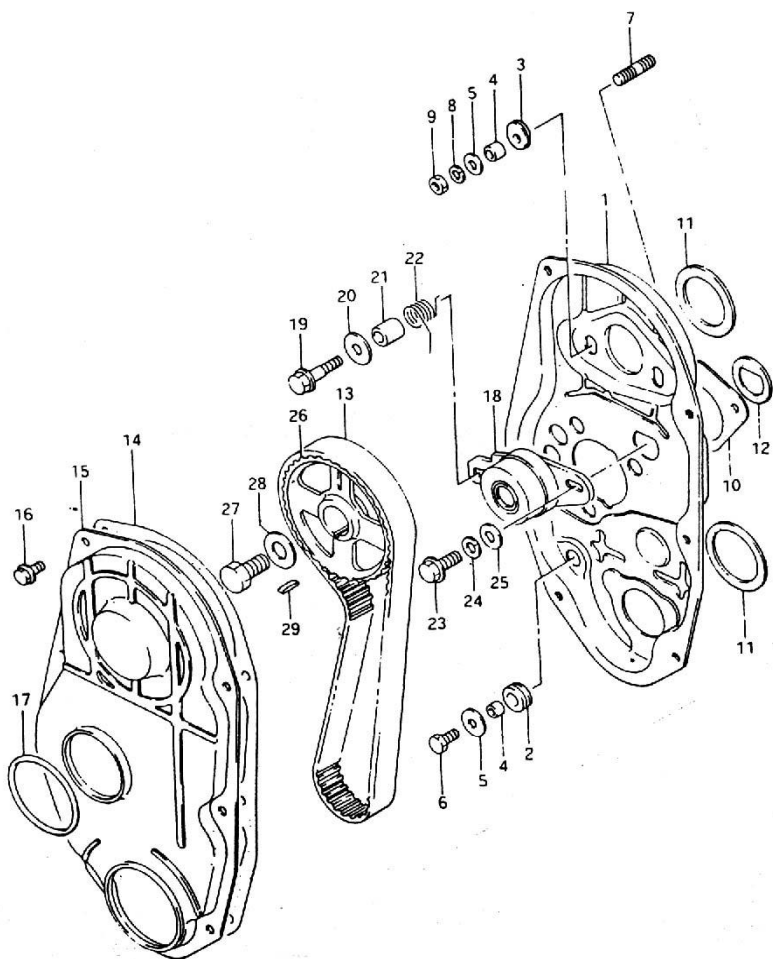

图1-7-1

序号 No.	零件序列号 PART SERIAL NO.	零部件编号 Part No.	名称 PART NAME	名称 PART NAME	数量 Qty	备注 Rem.
21		1000061D	扭簧衬套	Sleeve, coil spring	1	BD
22	01.09.00BD006 GHH368QA1	1000065D	扭簧	Coil spring	1	BD
23	01.09.00BD007 GHH368QA1	1000073D	张紧轮总成带肩螺栓	Bolt w/t flange, tension pulley comp.	1	BD
24		GB/T859—1987	垫圈8	Washer 8	1	BD
25			大垫圈8—A140HV	Washer 8—A140HV	1	BD
26	01.09.00BD009 GHH368QA1	1000101	凸轮轴正时皮带轮	Timing pulley, camshaft	1	BD
27			螺栓	Bolt	1	BD
28			垫圈12	Washer 12	4	BD
29		GB/T1099—1979	键5×19	Key 5×19	2	BD

图1-7-4

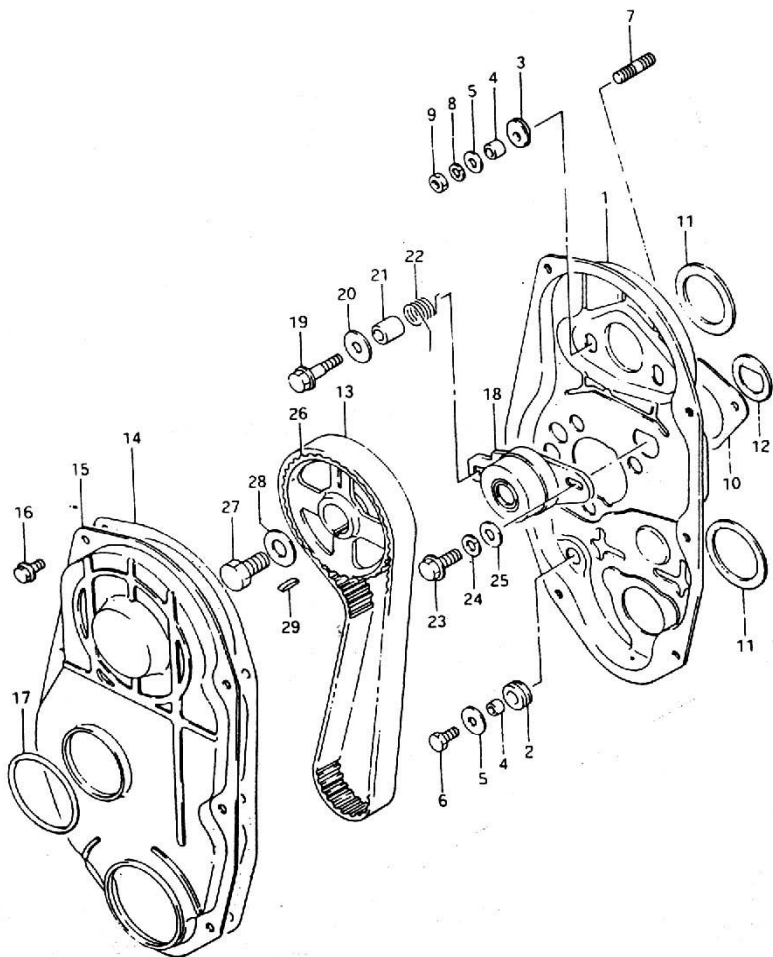

图1-7-4

序号 No.	零件序列号 PART SERIAL NO.	零部件编号 Part No.	名称 PART NAME	名称 PART NAME	数量 Qty	备注 Rem.
1	01.09.7110002 GHH465Q-2E	1021040E	正时链条总成	Timing chain comp.	1	7110
2			右导向板耐磨套	Wearable sleeve, guide plate, R.	1	7110
3			螺钉	Screw	2	7110
4			胶圈	Rubber ring	1	7110
5	01.09.7110003 GHH465Q-2E	1021010E	张紧器总成	Tensioning device comp.	1	7110
6		1021032E	螺栓 M8×25	Bolt M8×25	1	7110
7			右导向板定位套	Positioning sleeve, guide plate, R.	1	7110
8			右导向板耐磨块	Wearable sleeve, guide plate, R.	1	7110
9	01.09.7110004 GHH465Q-2E	1021031E	右导向板总成	Guide plate comp., R.	1	7110
10			左导向板定位螺栓	Positioning bolt, guide plate, L.	2	7110
11	01.09.7110005 GHH465Q-2E	1021020E	左导向板	Guide plate, L.	1	7110

图1-8-1

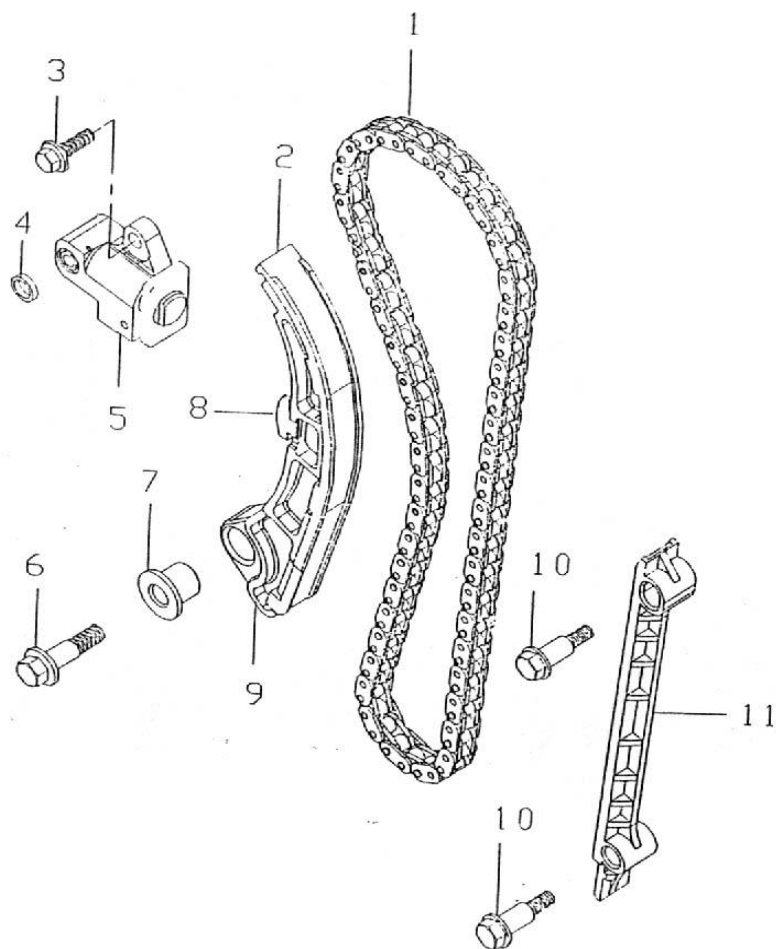

图1-8-1

序号 No.	零件序列号 PART SERIAL NO.	零部件编号 Part No.	名称 PART NAME	名称 PART NAME	数量 Qty	备注 Rem.
1	01.08.00BD002 GHH368QA1	1007010E	节气门体总成	Throttle valve comp.	1	BD
2	01.11.00BD004 GHH368QA1	3600040E	进气温度压力传感器	Sensor, intake air temperature & pressure	1	BD
3			螺钉	Screw	2	BD
4	01.08.00BD005 GHH368QA1	1008110	进气歧管总成	Intake manifold assy.	1	BD
5	01.08.00BD006 GHH368QA1	1000063E	进气歧管密封垫	Gasket, intake manifold	1	BD
6			夹子	Clamp	2	BD
7			螺钉	Screw	2	BD
8	01.11.00BD001 GHH368QA1	3600020E	水温传感器	Sensor, engine temperature	1	BD
9	01.11.00BD002 GHH368QA1	3600050E	步进电机	Step motor	1	BD
10	01.11.00BD003 GHH368QA1	3600090E	节气门位置传感器	Sensor, throttle position	1	BD
11	01.08.00BD004 GHH368QA1		节气门体密封垫		1	BD

图1-9-3

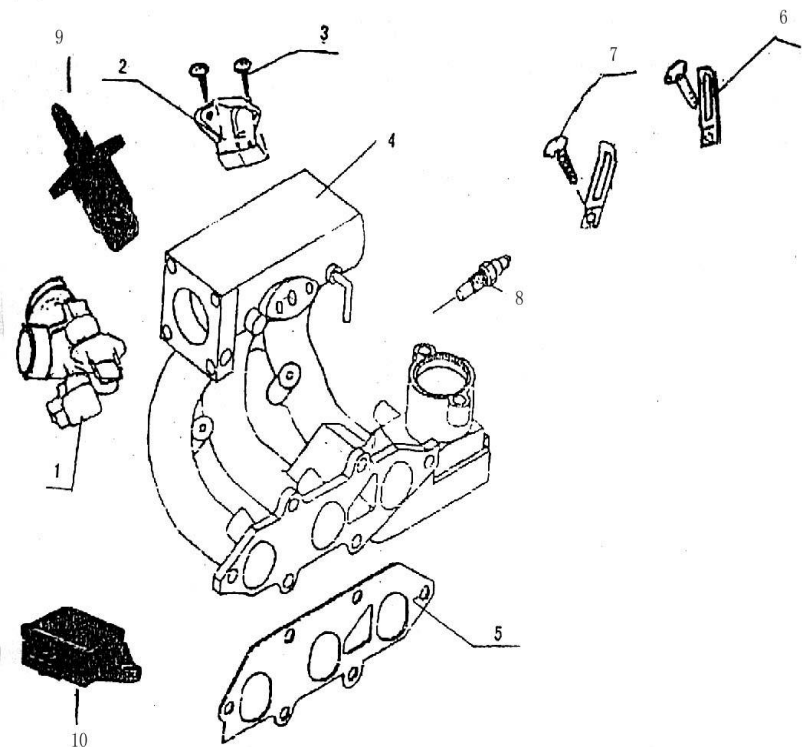

图1-9-3						
序号	零件序列号	零部件编号	名称	名称	数量	备注
No.	PART SERIAL NO.	Part No.	PART NAME	PART NAME	Qty.	Rem.
1	01.08.7110011 GHH465Q-2E	1008011E	排气歧管	Exhaust manifold	1	7110
2	01.11.7110005 GHH465Q-2E	3600070E	氧传感器	Oxygen sensor	1	7110
3	01.08.7110012 GHH465Q-2E	HH462QE. 1000054E	排气歧管 隔热垫总 成	Heat insulation plate, exhaust manifold	1	7110
4		HH368Q-1 E.1008012 E	双头螺柱	Stud	8	7110
5		GB/T6170- 1986	螺母M8	Nut M8	8	7110
6		HH465Q3. 1000079	排气歧管 地线总成	Earth cable comp., exhaust manifold	1	7110
7		GB/T5787- 1986	螺钉 M6×20	Screw M6×20	3	7110
8	01.08.7110013 GHH465Q-2E	1008013E	排气歧管 隔热罩总 成	Heat insulation shroud comp., exhaust manifold	1	7110

图1-10-1

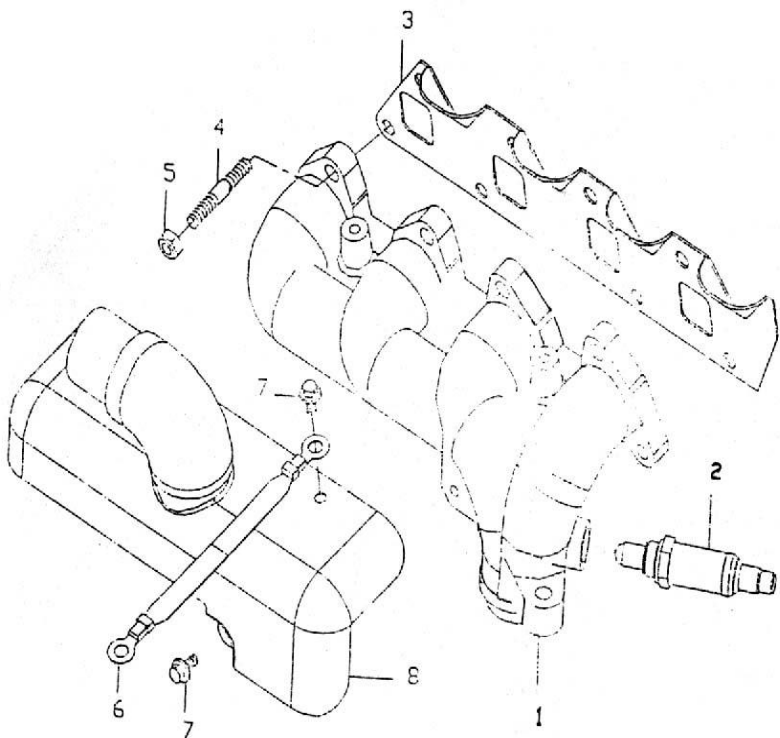

图1-10-1

序号	零件序列号	零部件编号	名称	名称	数量	备注
No.	PART SERIAL NO.	Part No.	PART NAME	PART NAME	Qty.	Rem.
1	01.05.00BD016 GHH368QA1	1011010D	机油泵总成	Oil pump comp.	1	BD
2			锥形螺塞	Threaded cone plug	1	BD
3			机油泵齿轮	Gear, oil pump	1	BD
4			机油泵齿圈	Toothed ring, oil pump	1	BD
5			泵盖	House, pump	1	BD
6		GB/T819— 1985	泵盖螺钉	Screw M6×12, pump house	6	BD
7			限压阀	Valve, pressure limiting	1	BD
8			限压阀弹簧	Spring, pressure limiting valve	1	BD
9			限压阀簧螺塞	Threaded plug	1	BD
10		1000051D	机油泵垫	Gasket, oil pump	1	BD
11		1000014	定位套 (机油泵安装用)	Position block, rear end plate, oil pump crankshaft	2	BD
12		1000083D	机油泵总成带肩螺栓	Bolt w/t flange	1	BD
13		1000084D	机油泵总成带肩螺栓	Bolt w/t flange	5	BD

图1-10-4

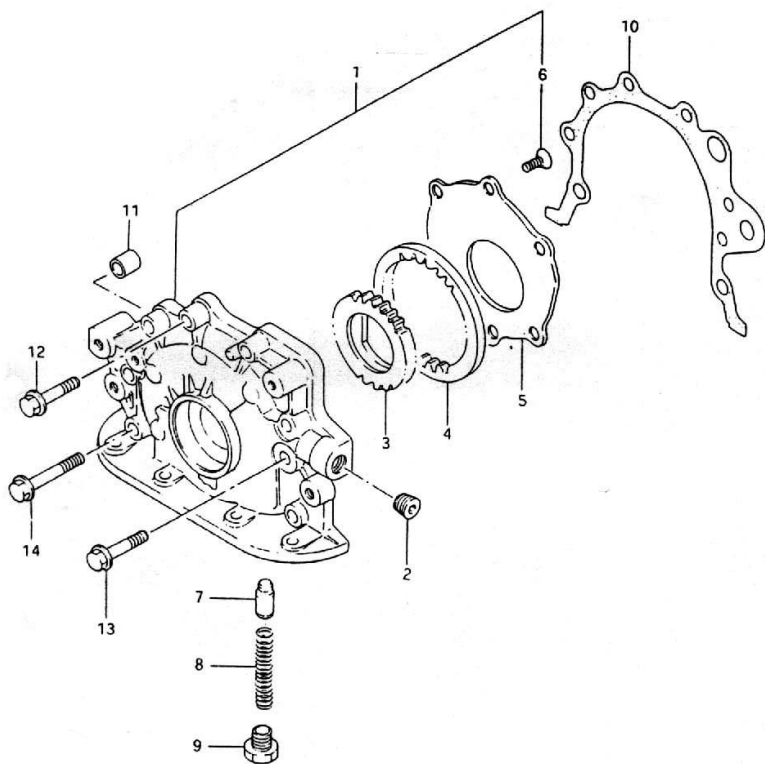

图1-10-4

序号 No.	零件序列号 PART SERIAL NO.	零部件编号 Part No.	名称 PART NAME	名称 PART NAME	数量 Qty	备注 Rem.
1	01.09.7110006 GHH465Q-2E	1011010E	前罩壳及机 油泵总成	Front house & oil pump assy.	1	7110
2		GB/T5787- 1986	螺钉M6×55	Screw M6×55	2	7110
3			碗型垫片	U-shaped washer	1	7110
4		GB/T5787- 1986	螺钉M6×45	Screw M6×45	1	7110
5		GB/T5787- 1986	螺钉M6×45	Screw M6×45	6	7110
6		GB/T5787- 1986	螺钉M6×45	Screw M6×45	2	7110
7		GB/T5787- 1986	螺钉M6×45	Screw M6×45	2	7110
8			调压活门	Pressure regulating valve	1	7110
9			弹簧	Spring	1	7110
10			弹簧座	Seat, spring	1	7110
11			螺堵	Threaded plug	1	7110
12		HH462Q.1 000014D	定位套	Positioning sleeve	4	7110
13	01.03.7110027 GHH465Q-2E	1002050E	机油尺总成	Oil gauge comp.	1	7110

图1-10-4

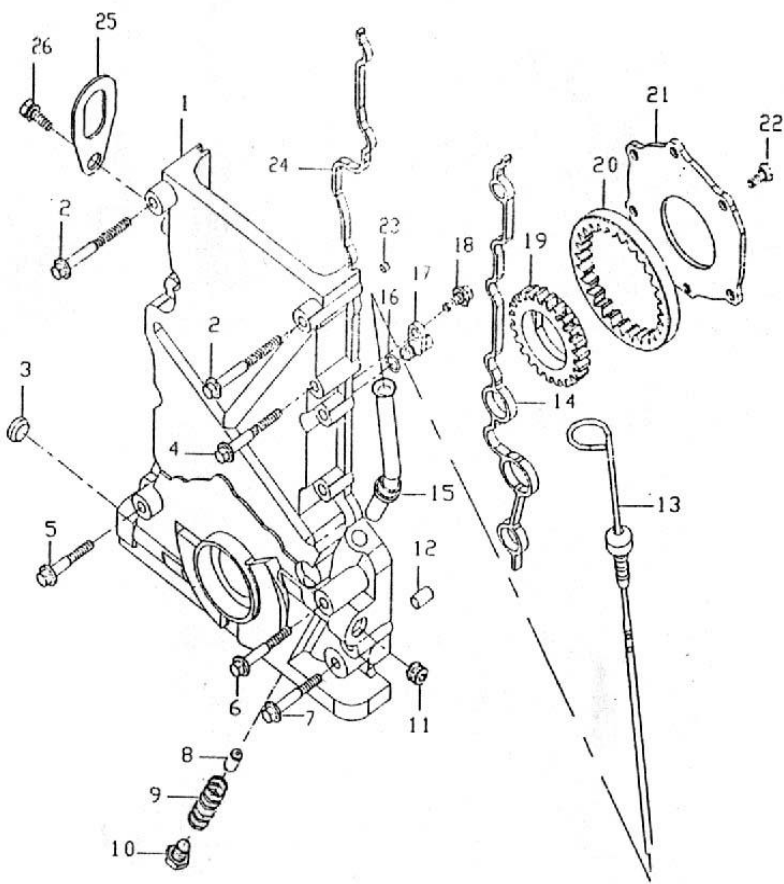

图1-10-4

序号	零件序列号	零部件编号	名称	名称	数量	备注
No.	PART SERIAL NO.	Part No.	PART NAME	PART NAME	Qty	Rem.
14	01.09.7110008 GHH465Q-2E	1011018E	前罩壳左密封条	Strip, front house seal, L.	1	7110
15			机油尺导管总成	Guide pipe comp., fuel level ruler	1	7110
16			胶圈	Rubber ring	1	7110
17			喷油嘴	Oil spray nozzle	1	7110
18		GB/T5787-1986	螺钉M8×20	Screw M8×20	1	7110
19			油泵外齿轮	External gear, oil pump	1	7110
20			油泵内齿轮	Internal gear, oil pump	1	7110
21			机油泵后盖	Rear plate, oil pump	1	7110
22			一字槽沉头螺钉	Slotted-head screw	6	7110
23			通油堵	Plug	1	7110
24	01.09.7110007 GHH465Q-2E	1011019E	前罩壳右密封条	Strip, front house seal, R.	1	7110
25		1000027E	发动机吊耳	Shackle, engine	1	7110
26		GB/T5783-1986	螺钉M8×20	Screw comp. M8×20	1	7110

图1-11-1

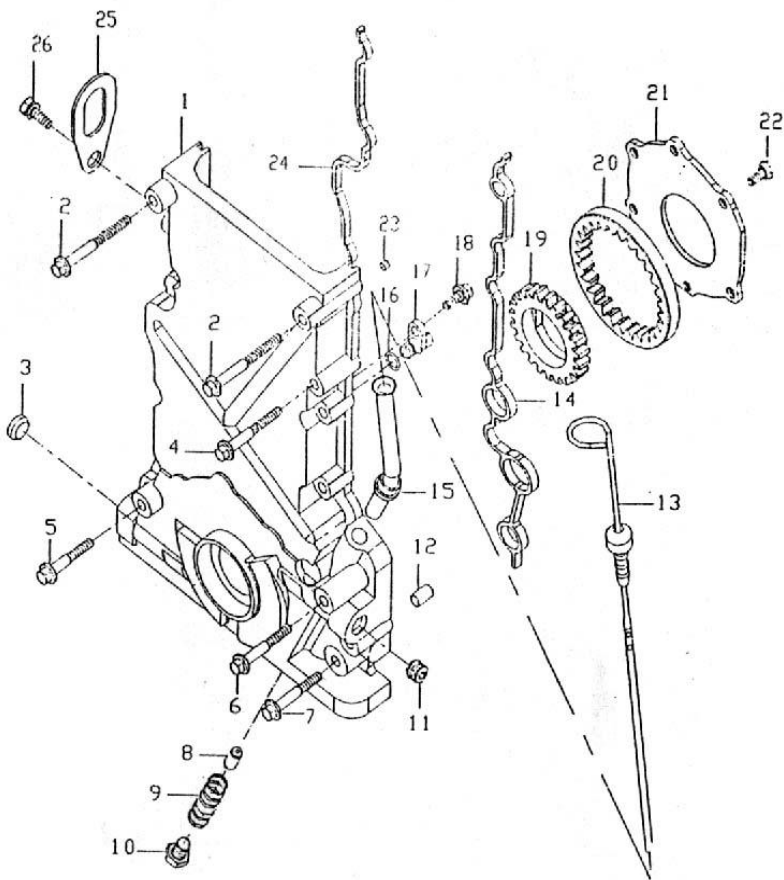

图1-11-1

序号 No.	零件序列号 PART SERIAL NO.	零部件编号 Part No.	名称 PART NAME	名称 PART NAME	数量 Qty	备注 Rem
1	01.10.00BD001 GHH368QA1	1307010D	水泵总成	Water pump comp.	1	BD
2		1000052D	水泵密封垫	Gasket, water pump	1	BD
3		1000092D	水泵总成 紧固双头 螺栓	Fastening stud, water pump comp.	2	BD
4			带肩六角 螺母	Nut w/t flange	2	BD
5			带肩螺栓	Bolt w/t flange	3	BD
6			螺栓	Bolt	3	BD
7	01.10.00BD002 GHH368QA1	1000017	水泵皮带 轮	Pulley, water pump belt	1	BD
8			带肩螺栓	Bolt w/t flange	4	BD
9	01.10.00BD003 GHH368QA1	1000077	水泵皮带	Belt, water pump	1	BD

图1-12-1

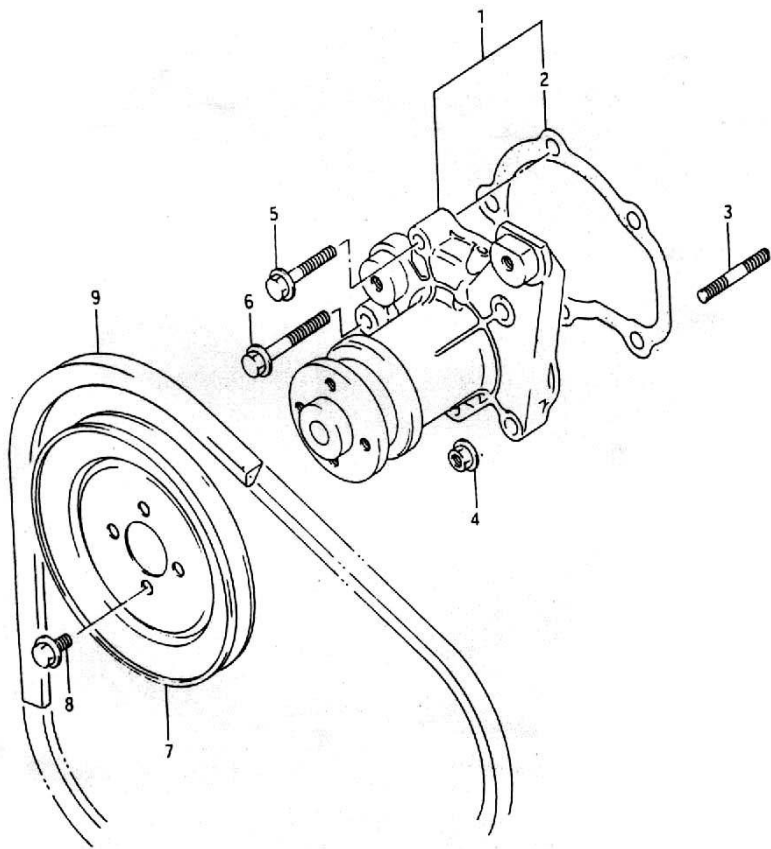

图1-12-1

序号 No.	零件序列号 PART SERIAL NO.	零部件编号 Part No.	名称 PART NAME	名称 PART NAME	数量 Qty.	备注 Rem.
1	02.04.00BD001 GHH368QA1	1600010	离合器盖总成	Cover comp., clutch	1	BD
2			螺栓	Bolt	2	BD
3			螺栓	Bolt	4	BD
4		GB/T859 —1987	弹垫8	Spring washer 8	2	BD
5	02.04.00BD002 GHH368QA1	1602010	离合器摩擦片 总成	Friction plate comp., clutch	1	BD
6	02.04.00BD003 GHH368QA1		分离轴承	Release bearing	1	BD
7			离合器分离轴 承护圈	Retainer, release bearing, clutch	1	BD
8	02.04.00BD005 GHH368QA1		卡簧	Snap ring	2	BD
9	02.04.00BD006 GHH368QA1		离合器分离轴 总成	Release shaft comp., clutch	1	BD
10	02.04.00BD004 GHH368QA1		轴套	Shaft sleeve	2	BD
11			弹簧	Spring	1	BD
12	02.04.00BD007 GHH368QA1		离合器分离臂	Release arm, clutch	1	BD
13		GB/T5789 —1986	带肩螺栓 AM8×35	Bolt W/T flange	1	BD
14		GB/T97.1 —1985	平垫8	Washer 8	1	BD
15		GB/T6170 —1986	螺母M8	Nut M8	1	BD

图1-12-4

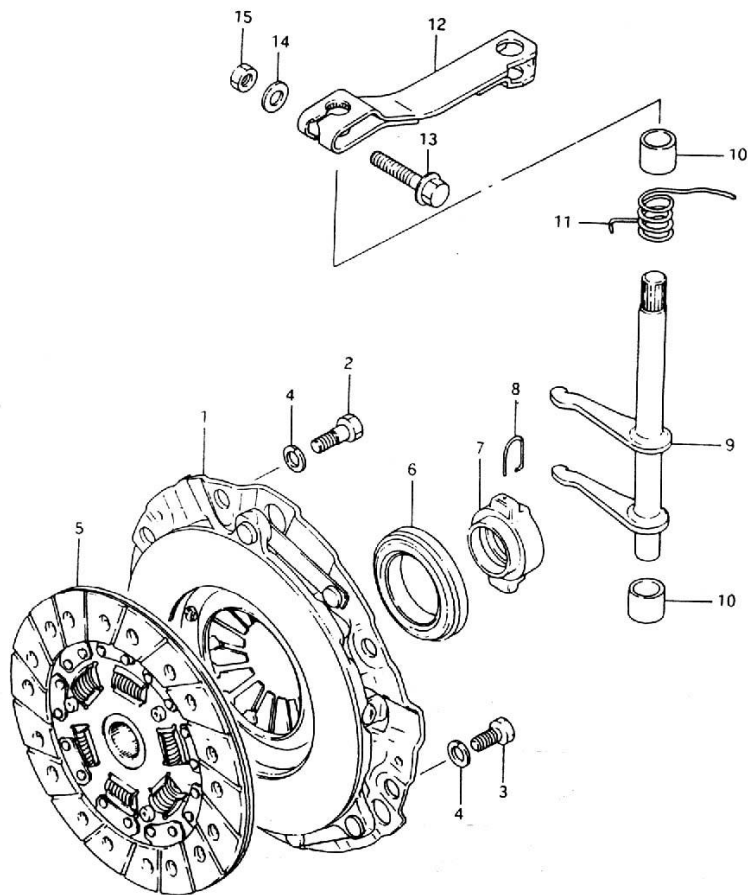

图1-12-4						
序号	零件序列号	零部件编号	名称	名称	数量	备注
No.	PART SERIAL NO.	Part No.	PART NAME	PART NAME	Qty	Rem.
1	02.04.7110012 GHH465Q-2E	1600010E	离合器压盘 及壳体总成	Pressure plate & house assy., clutch	1	7110
2			定位螺钉 M8×16	Positioning screw M8×16	2	7110
3		GB/T5783- 1986	螺钉M8×16	Screw M8×16	4	7110
4		GB/T859-1 987	弹簧垫圈8	Spring washer 8	2	7110
5	02.04.7110013 GHH465Q-2E	1602010E	离合器摩擦 片总成	Friction plate comp., clutch	1	7110

图1-13-1

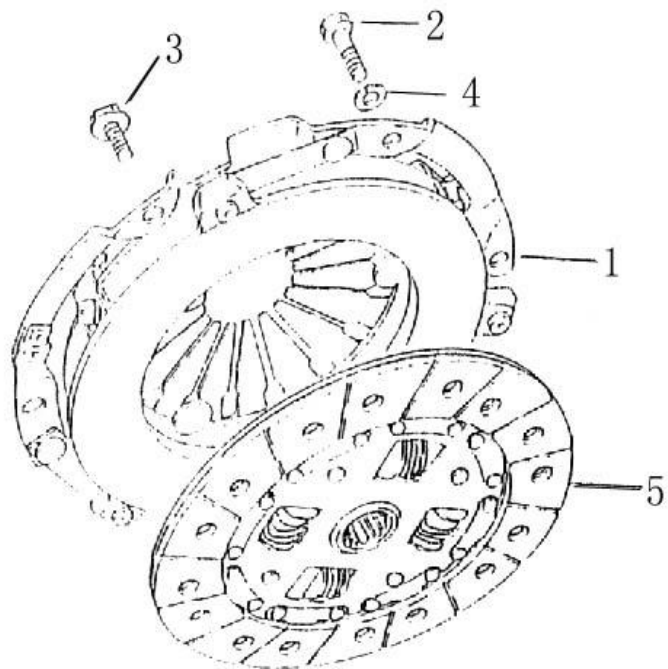

图1-13-1

序号 No.	零件序列号 PART SERIAL NO.	零部件编号 Part No.	名称 PART NAME	名称 PART NAME	数量 Qty.	备注 Rem.
1	02.02.00BD028GHH368QA1	1701130	一轴组件	Shaft kit 1#	1	BD
2	02.02.00BD031GHH368QA1	GB/T276—1994	输入轴轴承 (右)3G180204	Bearing, input shaft, R.	1	BD
3	02.02.00BD032GHH368QA1 02.02.00BD079GHH368QA1	1701310	一轴密封圈总成	Seal ring comp., shaft 1#	1	BD
4	02.02.00BD033GHH368QA1	GB/T276—1994	输入轴轴承 (左)3G180303	Bearing, input shaft, L.	1	BD
5	02.02.00BD034GHH368QA1	1701011	C型环	C ring	1	BD
6	02.02.00BD035GHH368QA1	1701120	一轴密封盖总成	Seal cap comp., shaft 1#	1	BD
7	02.02.00BD036GHH368QA1	1701201	中间轴	Intermediate shaft	1	BD
8	02.02.00BD038GHH368QA1	1701200	无内圈带止动槽圆柱滚子轴承	Cylinder roller bearing	1	BD
9	02.02.00BD039GHH368QA1	1701013	C型	C ring	1	BD
10	02.02.00BD040GHH368QA1	1701060	中间轴密封盖总成(右)	Seal cap comp., inter. Shaft, R.	1	BD
11	02.02.00BD041GHH368QA1	GB/T276—1994	轴承3G50304	Bearing	1	BD
12	02.02.00BD042GHH368QA1	1701012	C型环	C plug	1	BD
13	02.02.00BD043GHH368QA1	1701219	中间轴紧固螺母	Retaining nut, inter. Shaft	1	BD
14	02.02.00BD044GHH368QA1	1701050	中间轴密封盖总成(左)	Seal cap comp., inter. Shaft, L.	1	BD
15	02.02.00BD045GHH368QA1	1701211	中间轴一档齿轮	Gear 1#, intermediate shaft	1	BD
16		GB/T309—1984	滚针P2×7.8	Needle P2×7.8	1	BD
17	02.02.00BD046GHH368QA1	1701203	中间轴一档齿轮垫圈	Washer, gear 1# ,inter. Shaft	1	BD
18		GB/T308—1989	钢球4.7625G60b	Steel ball	1	BD

图1-13-1

序号 No.	零件序列号 PART SERIAL NO.	零部件编号 Part No.	名称 PART NAME	名称 PART NAME	数量 Qty.	备注 Rem.
19	02.02.00BD047GHH368QA1	1701204	中间轴一档齿轮轴套	Bush, gear 1#, intermiate shaft	1	BD
20	02.02.00BD048GHH368QA1	JB/T7918—1997	轴承K253024	Bearing	1	BD
21	02.02.00BD049GHH368QA1	1701212	中间轴二档齿轮	Gear 2#, intermiate shaft	1	BD
22	02.02.00BD050GHH368QA1	1701213	中间轴三档齿轮	Gear 3#, intermiate shaft	1	BD
23	02.02.00BD051GHH368QA1	1701205	二、三档齿轮轴套	Shaft bush, gear 2# & 3#	2	BD
24	02.02.00BD052GHH368QA1	JB/T7918—1997	轴承K303520	Bearing	2	BD
25	02.02.00BD053GHH368QA1	1701206	二、三档齿轮垫圈	Washer, gear 2# & 3#	2	BD
26	02.02.00BD054GHH368QA1	1701208	三档齿调整垫	Adjustment washer, gear 3#	1	BD
27	02.02.00BD055GHH368QA1	1701207	二、三档齿轮压簧	Pressure spring, gear 2# & 3#	1	BD
28	02.02.00BD056GHH368QA1	1701214	中间轴四档齿轮	Gear 4#, inter. Shaft	1	BD
29	02.02.00BD057GHH368QA1	JB/T7918—1997	轴承K253020	Bearing	1	BD
30			垫圈	Washer	1	BD
31	02.02.00BD059GHH368QA1	1701232	低速同步器毂	Synchronizer hub, low speed	1	BD
32	02.02.00BD060GHH368QA1	1701231	低速同步器套	Sleeve, low speed synchronizer	1	BD
33	02.02.00BD061GHH368QA1	1701215	低速同步器齿环(左)	Toothed ring, low speed synchronizer, L.	1	BD
34	02.02.00BD062GHH368QA1	1701217	低速同步器齿环弹簧	Spring, toothed ring, low speed synchronizer	1	BD
35	02.02.00BD063GHH368QA1	1701216	低速同步器齿环(右)	Toothed ring, low speed synchronizer, R.	1	BD

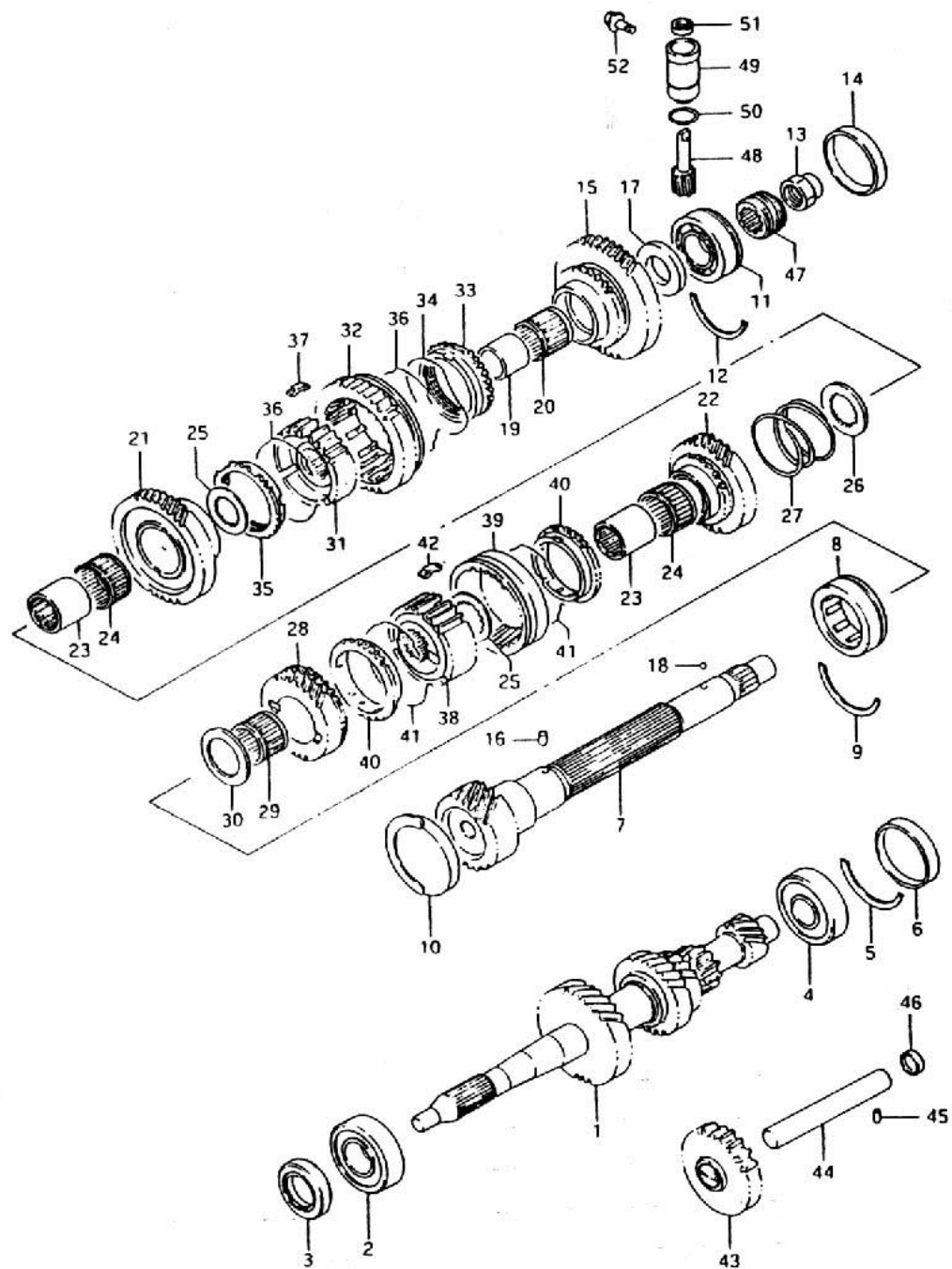
图1-13-1

序号 No.	零件序列号 PART SERIAL NO.	零部件编号 Part No.	名称 PART NAME	名称 PART NAME	数量 Qty.	备注 Rem.
36	02.02.00BD064GHH368QA1	1701233	低速同步器弹簧	Spring, low speed synchronizer	2	BD
37	02.02.00BD065GHH368QA1	1701234	同步器滑块	Key, synchronizer	3	BD
38	02.02.00BD066GHH368QA1	1701242	高速同步器毂	Hub, high speed synchronizer	1	BD
39	02.02.00BD067GHH368QA1	1701241	高速同步器套	Sleeve, high speed synchronizer	1	BD
40	02.02.00BD068GHH368QA1	1701218	高速同步器齿环	Toothed ring, high speed synchronizer	2	BD
41	02.02.00BD086GHH368QA1	1701243	高速同步器弹簧	Spring, high speed synchronizer	2	BD
42		1701234	同步器滑块	Key, synchronizer	3	BD
43	02.02.00BD069GHH368QA1	1701081	倒档空转齿轮	Gear, reverse gear, idle	1	BD
44	02.02.00BD070GHH368QA1	1701015	变速器倒档齿轮轴	Shaft, reverse gear	1	BD
45		GB/T119—1986	销D5×13	Pin D5×13	1	BD
46	02.02.00BD071GHH368QA1	1701070	倒档齿轮轴密封盖总成	Seal cap comp., reverse gear shaft	1	BD
47	02.02.00BD072GHH368QA1	1701202	速度、里程表蜗杆	Worm mileage meter & speedometer	1	BD
48	02.02.00BD073GHH368QA1	1701209	速度、里程表蜗轮	Worm gear mileage meter & speedometer	1	BD
49	02.02.00BD074GHH368QA1	1701401	速度、里程表蜗轮轴套	Bush ,mileage meter & speedometer worm gear	1	BD
50	02.02.00BD075GHH368QA1	GB/T3452.1—1992	圆形密封圈19×1.8	O seal 19×1.8	1	BD
51		1701410	密封圈总成	Seal ring comp.	1	BD
52	02.02.00BD077GHH368QA1	1701028	速度计止推螺钉	Thrust screw, speedometer	1	BD

图1-13-4.1



图1-13-4.1

序号 No.	零件序列号 PART SERIAL NO.	零部件编号 Part No.	名称 PART NAME	名称 PART NAME	数量 Qty	备注 Rem.
1	02.02.7110044 GHH465Q-2E	4T08-170 1101	输入轴	Input shaft	1	7110
2	02.02.7110045 GHH465Q-2E	5T07-170 1080	输入轴密封圈 总成	Seal comp., input shaft	1	7110
3		GB/T276 -1994	轴承6204/P53	Bearing 6204/P53	1	7110
4	02.02.7110046 GHH465Q-2E	4T08-170 1120	输入轴三档齿 轮组件	Gear comp.3#, input shaft	1	7110
5	02.02.7110048 GHH465Q-2E	5T07-170 1150	三档齿轮滚针 轴承	Needle bearing, gear 3#	1	7110
6	02.02.7110049 GHH465Q-2E	5T07-170 1102	三、四档同步 器齿环	Toothed ring, gear 3# & 4# synchronizer	2	7110
7	02.02.7110050 GHH465Q-2E		三、四档同步 器组件	Synchronizer kit, gear 3# & 4#	1	7110
8		5T07-170 1134	三、四档同步 器毂	Synchronizer hub, gear 3# & 4#	1	7110
9		5T07-170 1131	三、四档同步 器套	Synchronizer sleeve, gear 3# & 4#	1	7110
10	02.02.7110051 GHH465Q-2E	5T07-170 1133	三、四档同步 器弹簧	Spring, gear 3# & 4# synchronizer	2	7110
11		5T07-170 1132	三、四档同步 器滑块	Slide, gear 3# & 4# synchronizer	3	7110

图1-13-4.1

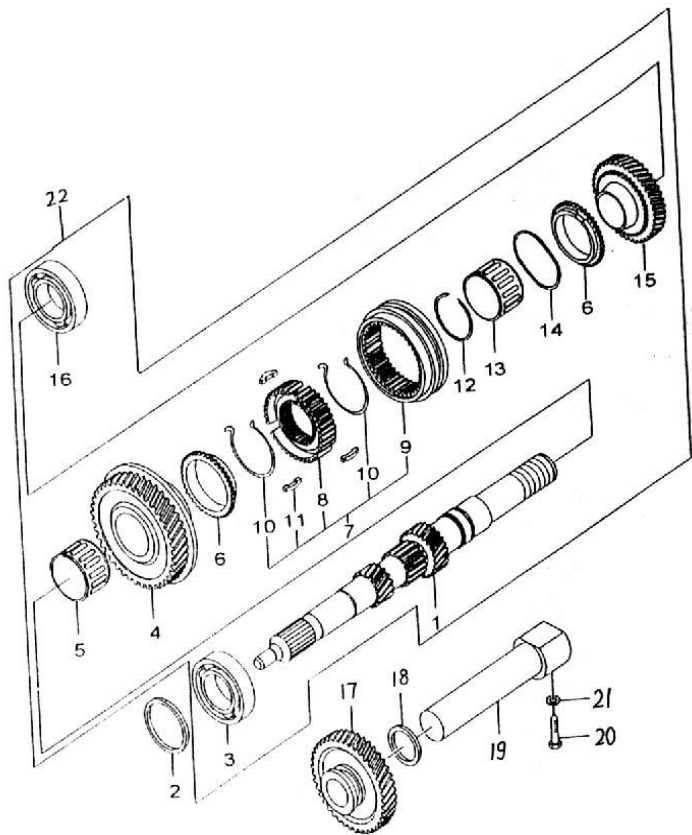

图1-13-4.1

序号 No.	零件序列号 PART SERIAL NO.	零部件编号 Part No.	名称 PART NAME	名称 PART NAME	数量 Qty	备注 Rem.
12	02.02.7110052 GHH465Q-2E	5T07-170 1103	三、四档同步器挡圈	Retaining ring, gear 3# & 4# synchronizer	1	7110
13		GB/T791 8-1997	滚针轴承 K25×30×2 4	Needle bearing K25×30×24	1	7110
14		5T07-170 1105	四档同步器齿环弹簧	Spring, toothed ring, gear 4# synchronizer	1	7110
15	02.02.7110047 GHH465Q-2E	4T08-170 1110	输入轴四档齿轮组件	Gear 4# comp., input shaft	1	7110
16	02.02.7110054 GHH465Q-2E	5T07-170 1110	输入轴左轴承	Bearing, input shaft, L.	1	7110
17	02.02.7110055 GHH465Q-2E	5T07-170 1070	倒档惰轮组件	Pinion comp., reverse gear	1	7110
18	02.02.7110056 GHH465Q-2E	5T07-170 1053	倒档惰轮挡环	Retaining ring, reverse gear pinion	1	7110
19	02.02.7110057 GHH465Q-2E	5T07-170 1060	倒档惰轮轴组件	Shaft comp., reverse gear pinion	1	7110
20	02.02.7110058 GHH465Q-2E	5T07-170 1057	倒档轴锁紧螺栓	Locking bolt, reverse gear shaft	1	7110
21	02.02.7110059 GHH465Q-2E	5T07-170 1052	倒档轴螺栓垫圈	Washer, reverse gear shaft bolt	1	7110
22		4T08-170 1100	输入轴组件	Input shaft comp.	1	7110

图1-13-4.2

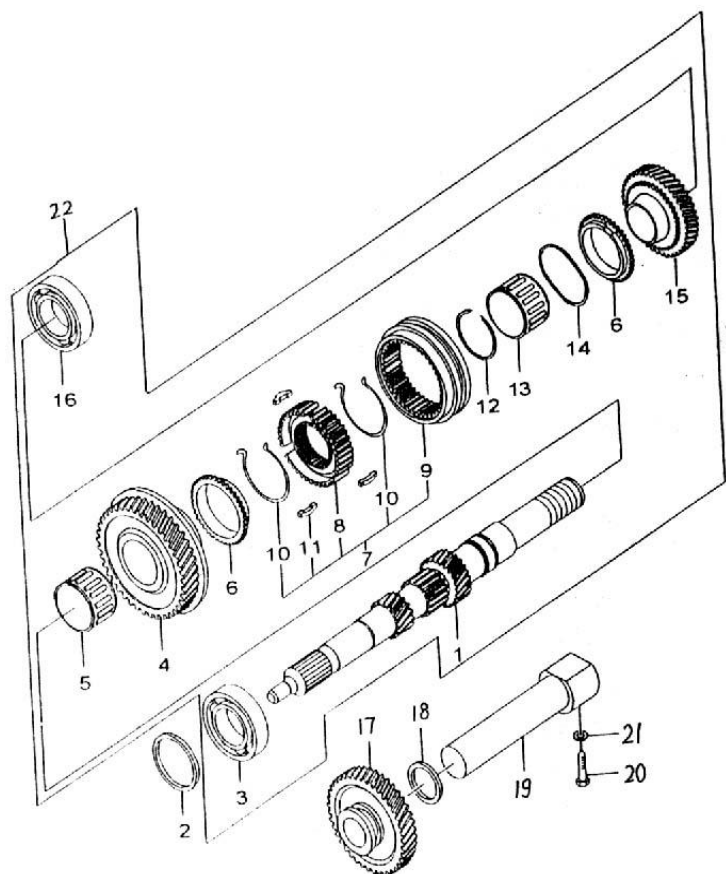

图1-13-4.2

序号 No.	零件序列号 PART SERIAL NO.	零部件编号 Part No.	名称 PART NAME	名称 PART NAME	数量 Qty	备注 Rem.
1	02.02.7110061 GHH465Q-2E	4T08-170 1204	中间轴	Intermediate shaft	1	7110
2	02.02.7110062 GHH465Q-2E	5T07-170 1230	中间轴一档 齿轮组件	Gear comp. 1#, intermediate shaft	1	7110
3	02.02.7110063 GHH465Q-2E	5T07-170 1210	中间轴二档 齿轮组件	Gear comp.2#, intermediate shaft	1	7110
4	02.02.7110064 GHH465Q-2E	4T08-170 1203	中间轴三档 齿轮	Gear 3#, intermediate shaft	1	7110
5	02.02.7110065 GHH465Q-2E	4T08-170 1202	中间轴四档 齿轮	Gear 4#, intermediate shaft	1	7110
6	02.02.7110066 GHH465Q-2E		轴承33005	Bearing 33005	1	7110
7	02.02.7110067 GHH465Q-2E	5T07-170 1240	一档齿轮滚 针轴承	Needle bearing, gear 1#	1	7110
8	02.02.7110068 GHH465Q-2E	5T07-170 1206	一档同步器 齿环	Toothed ring, synchronizer, gear 1#	1	7110
9	02.02.7110069 GHH465Q-2E		一、二档同 步器组件	Synchronizer comp., gear 1# & 2#	1	7110
10		5T07-170 1223	弹簧	Spring	2	7110

图1-13-4.2

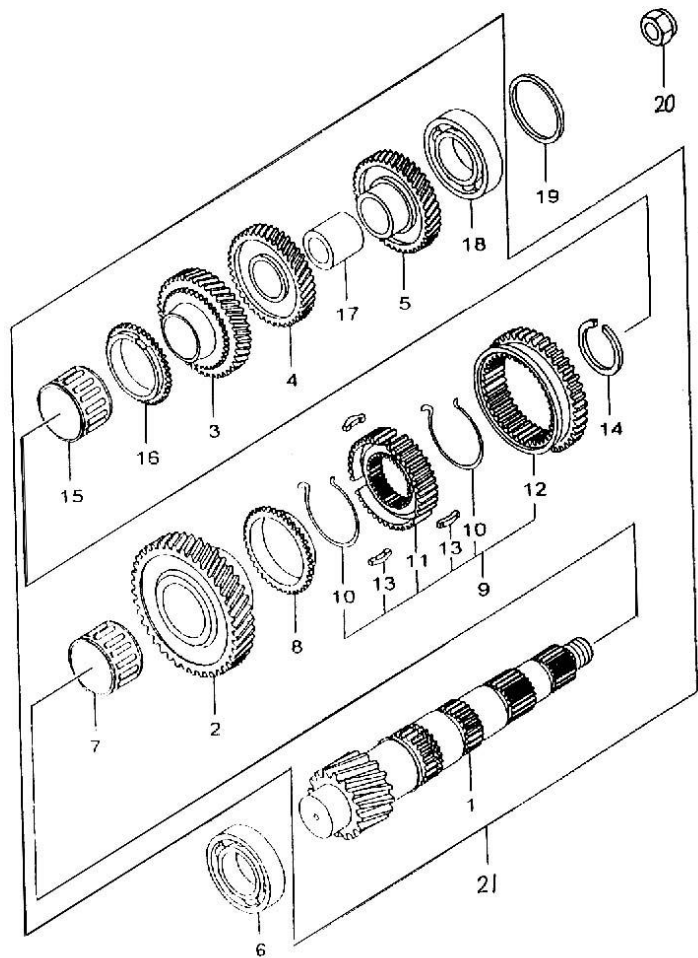

图1-13-4.2

序号 No.	零件序列号 PART SERIAL NO.	零部件编号 Part No.	名称 PART NAME	名称 PART NAME	数量 Qty	备注 Rem.
11		5T07-170 1224	一、二档同步器毂	Synchronizer hub, gear 1# & 2#	1	7110
12		5T07-170 1221	一、二档同步器套	Synchronizer sleeve, gear 1# & 2#	1	7110
13		5T07-170 1222	一、二档同步器滑块	Synchronizer key, gear 1# & 2#	3	7110
14	02.02.7110070 GHH465Q-2E	5T07-170 1205	一、二档同步器挡圈	Retaining ring, synchronizer, gear 1# & 2#	1	7110
15		GB/T791 8-1997	滚针轴承 K30×35×2 5	Needle bearing K30×35×25	1	7110
16	02.02.7110071 GHH465Q-2E	5T07-170 1204	二档同步器齿环	Toothed ring, synchronizer, gear 2#	1	7110
17	02.02.7110053 GHH465Q-2E	5T07-170 1202	三、四档齿轮隔套	Distance sleeve, gear 3# & 4#	1	7110
18	02.02.7110101 GHH465Q-2E	GB/T297 -1994	轴承32004	Bearing 32004	1	7110
19	02.02.7110072 GHH465Q-2E	5T07-170 1005	中间轴轴承调整垫	Adjustment shim, intermediate shaft bearing	1	7110
20	02.02.7110105 GHH465Q-2E		中间轴紧固螺母	Fixing nut, intermediate shaft	1	7110
21		4T08-170 1200	中间轴组件	Intermediate shaft comp.	1	7110

图1-14-1

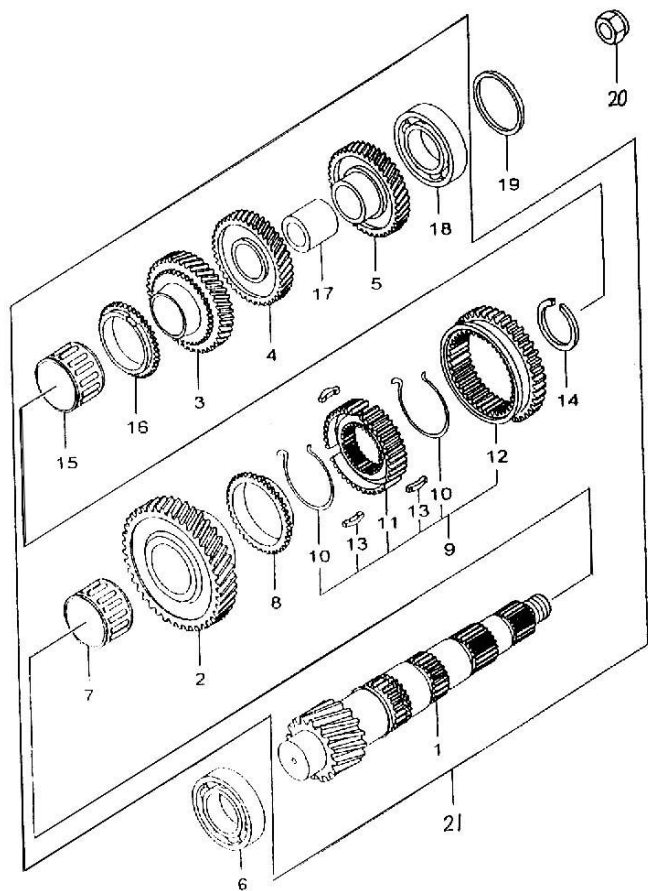

图1-14-1

序号 No.	零件序列号 PART SERIAL NO.	零部件编号 Part No.	名称 PART NAME	名称 PART NAME	数量 Qty.	备注 Rem.
1	02.01.00BD001 GHH368QA1	1701010	变速器总成	Gearbox assy.	1	BD
2	02.02.00BD078 GHH368QA1	1701113	定位销	Pin	2	BD
3		GB/T5790—1986	螺栓AM6×40	Bolt AM6×40	1	BD
4		GB/T5790—1986	螺栓AM8×50	Bolt AM8×50	10	BD
5		GB/T5790—1986	螺栓AM8×70	Bolt AM8×70	5	BD
6		GB/T5790—1986	螺栓AM8×90	Bolt AM8×90	1	BD
7		GB/T5790—1986	螺栓AM8×135	Bolt AM8×135	1	BD
8	02.02.00BD080 GHH368QA1	1701301	一轴密封圈挡 板	Plate, seal ring, shaft 1#	1	BD
9		GB/T3452.1—1992	输入轴油封 “O”形环 40×2.65	O ring, input shaft oil seal,40×2.65	1	BD
10		GB/T819—1985	螺钉 M6×16—6.8	Screw M6×16-6.8	4	BD
11	02.02.00BD081 GHH368QA1	1701140	油尺总成	Fuel level ruler comp.	1	BD
12		GB/T3452.1—1992	圆形密封圈 17×1.8	O seal 17×1.8	1	BD
13		QC/T378—1999	螺塞 Z1/2"—14	Threaded plug Z1/2"-14	1	BD

图1-14-1

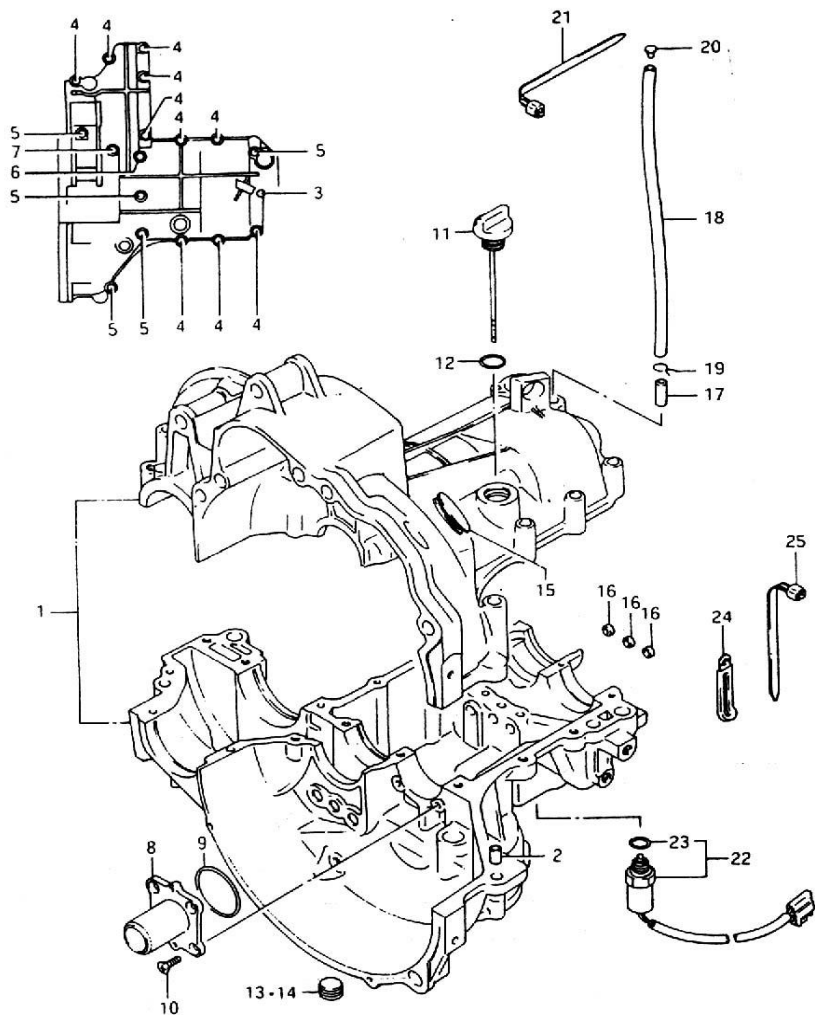

图1-14-1						
序号	零件序列号	零部件编号	名称	名称	数量	备注
No.	PART SERIAL NO.	Part No.	PART NAME	PART NAME	Qty	Rem.
14		QC/T384—1999	变速器放油塞 Z1/2"—14 (磁性)	Magnetic, gearbox drainage plug Z1/2"-14	1	BD
15	02.02.00BD082 GHH368QA1	1701017	(正时检查) 观察窗盖	Cover, sight hole (timing checking)	1	BD
16		1702050	换挡拨叉轴 止动塞	Blocking plug, shift fork shaft	3	BD
17	02.02.00BD097 GHH368QA1	1701025	通气管接头	Connector, vent pipe	1	BD
18	02.02.00BD083 GHH368QA1	1701026	通气管	Vent pipe	1	BD
19	02.02.00BD096 GHH368QA1	1701023	管卡	Clamp	1	BD
20	02.02.00BD084 GHH368QA1	1701027	通气管塞	Plug, vent pipe	1	BD
21	02.02.00BD095 GHH368QA1	1701024	线卡	Clamp	1	BD
22	02.02.00BD085 GHH368QA1	3729010	倒车灯开关 总成	Switch comp., back-up light	1	BD
23		GB/T345 2.1—199 2	“O”形环 11.8×1.8	O ring	1	BD
24			夹子	Clamp	1	BD
25		1701024	线束夹	Clamp, harness	1	BD

图1-14-4

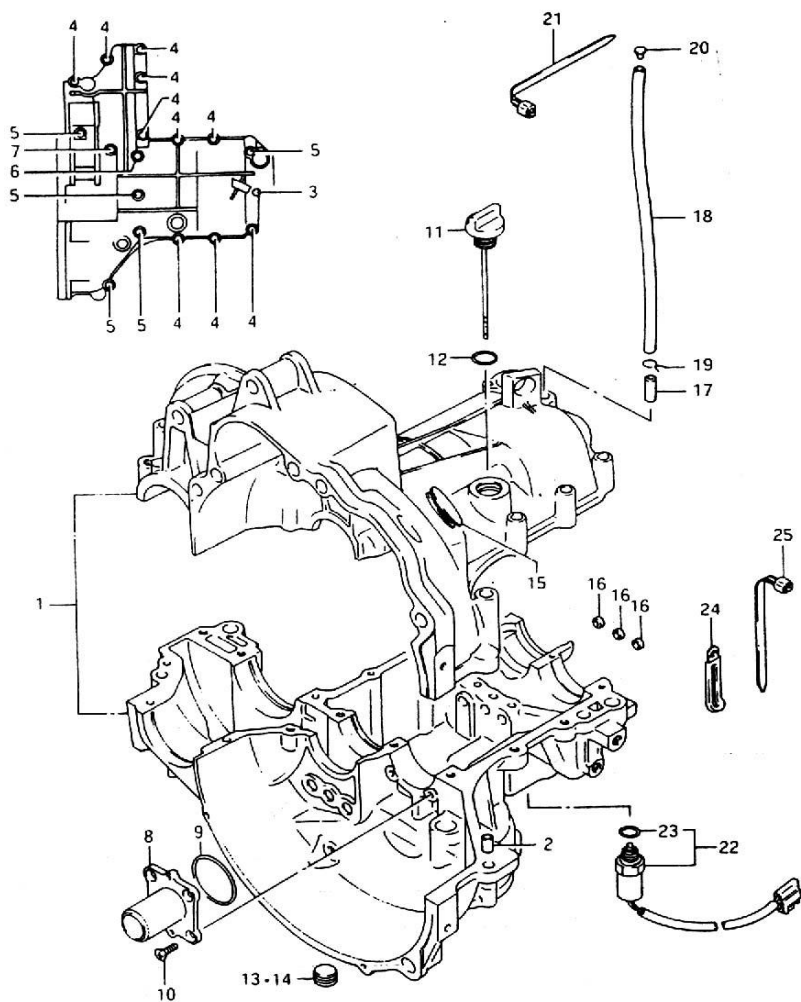

图1-14-4

序号	零件序列号	零部件编号	名称	名称	数量	备注
No.	PART SERIAL NO.	Part No.	PART NAME	PART NAME	Qty	Rem.
1		4T08-170 1001	右箱体	house, R.	1	7110
2		5T07-170 1051	左箱体	house, L.	1	7110
3	02.02.7110073 GHH465Q-2E	4T08-170 1010	侧盖	Side cover	1	7110
4	02.04.7110015 GHH465Q-2E	5T07-170 2010	离合器分离 轴承	Release bearing, clutch	1	7110
5	02.04.7110016 GHH465Q-2E	5T07-170 2020	离合器拨叉 轴总成	Shaft comp., clutch fork	1	7110
6	02.04.7110017 GHH465Q-2E	5T07-170 2001	离合器拨叉 轴轴套(1)	Bush1 #, clutch fork shaft	1	7110
7	02.04.7110018 GHH465Q-2E	5T07-170 2030	离合器拨叉 轴密封圈总 成	Seal comp., clutch fork shaft	1	7110
8	02.04.7110019 GHH465Q-2E	5T07-170 2004	离合器拨叉 轴轴套(2)	Bush2 #, clutch fork shaft	1	7110
9		GB/T879 -1986	销3×10	Pin 3×10	1	7110
10		GB/T578 9-1986	螺栓 AM8×40	Bolt AM8×40	14	7110
11			线卡	Clamp	1	7110
12		GB/T119 -1986	定位销	Pin	2	7110

图1-14-4

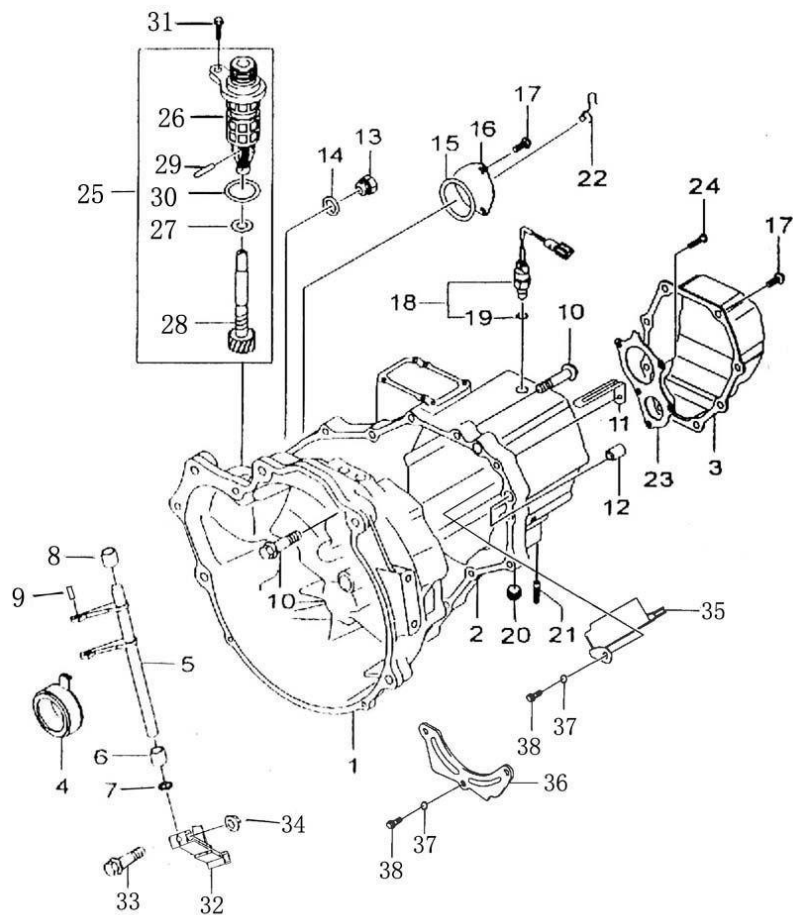

图1-14-1

序号 No.	零件序列号 PART SERIAL NO.	零部件编号 Part No.	名称 PART NAME	名称 PART NAME	数量 Qty	备注 Rem.
13	02.04.7110020 GHH465Q-2E	5T07-170 1002	注油螺塞	Threaded plug, oil filler	1	7110
14	02.04.7110022 GHH465Q-2E	5T07-170 1003	注油螺塞垫 圈	Washer, threaded plug	1	7110
15		GB/T 3452.1-1 986	O型密封圈 51.5×1.9	O seal 51.5×1.9	1	7110
16	02.04.7110023 GHH465Q-2E	5T07-170 1056	盖板	Cover	1	7110
17		GB/T578 9-1986	螺栓 AM6×12	Bolt AM6×12	13	7110
18	02.02.7110001 GHH465Q-2E	5T07-372 9010	倒车灯开关 总成	Back-up light switch comp.	1	7110
19			O型密封圈 11.8×1.8	O seal 11.8×1.8	1	7110
20		ZBT3200 1.9-1987	螺塞Z1/2	Threaded plug Z1/2	1	7110
21			双头螺柱	Stud	1	7110
22			钢丝卡	Steel thread snap ring	1	7110
23	02.04.7110024 GHH465Q-2E	5T07-170 1009	轴承挡板	Bearing guard	1	7110
24		GB/T819 -1985	螺钉 M6×16-6.8	Screw M6×16-6.8	5	7110
25	02.02.7110005 GHH465Q-2E	5T07-170 1500	速度计从动 齿轮总成	Driven gear comp., speedometer	1	7110

图1-14-4

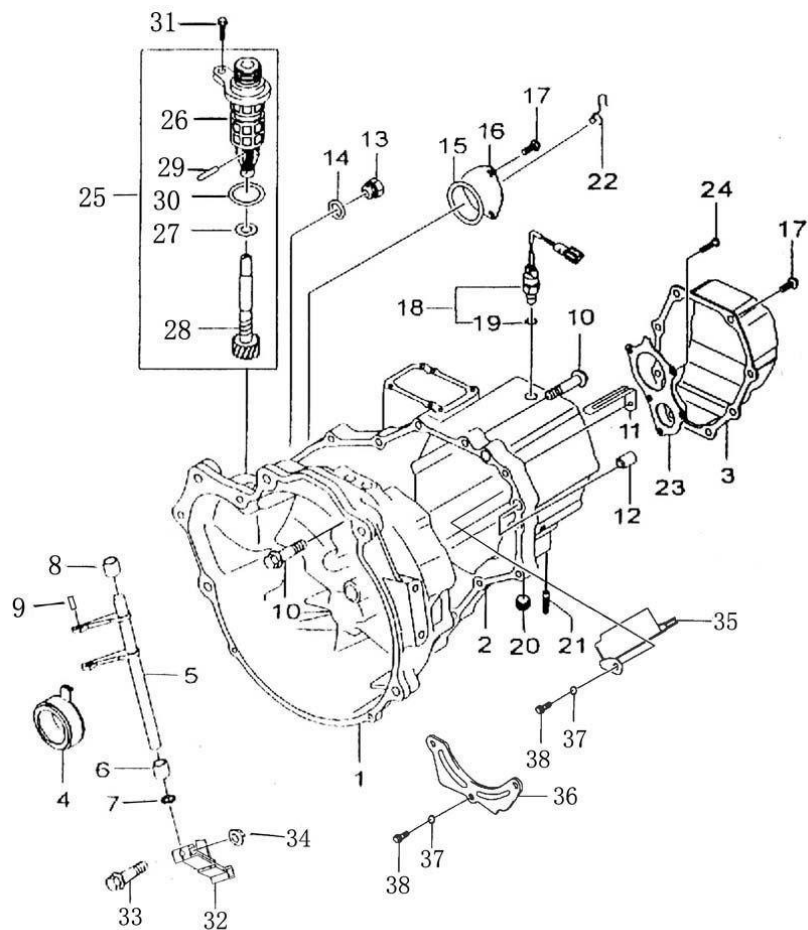

图1-14-1

序号 No.	零件序列号 PART SERIAL NO.	零部件编号 Part No.	名称 PART NAME	名称 PART NAME	数量 Qty	备注 Rem.
26	02.02.7110006 GHH465Q-2E	5T07-170 1501	速度计从动齿 轮轴套	Bush, driven gear, speedometer	1	7110
27	02.02.7110007 GHH465Q-2E	5T07-170 1502	速度计从动齿 轮垫圈	Washer, driven gear, speedometer	1	7110
28	02.02.7110008 GHH465Q-2E	5T07-170 1503	速度计从动齿 轮	Driven gear, speedometer	1	7110
29			销3×16	Pin 3×16	1	7110
30		GB/T345 2.1-1986	O型密封圈 16×3.55	O seal 16×3.55	1	7110
31		GB/T578 9-1986	螺栓BM6×16	Bolt BM6×16	1	7110
32	02.04.7110021 GHH465Q-2E	5T07-170 2080	离合器转臂组 件	Arm kit, clutch	1	7110
33		GB/T578 9-1986	螺栓AM8×35	Bolt AM8×35	1	7110
34		GB/T617 7-1986	螺母M8	Nut M8	1	7110
35	02.04.7110025 GHH465Q-2E	5T07-170 1400	油槽总成	Lubricating oil groove comp	1	7110
36	02.04.7110026 GHH465Q-2E		挡油板	Blocking oil plate	1	7110
37	02.02.7110086 GHH465Q-2E		垫圈6	Washer 6	4	7110
38			螺栓M6×12	Bolt M6×12	4	7110

图1-14-5

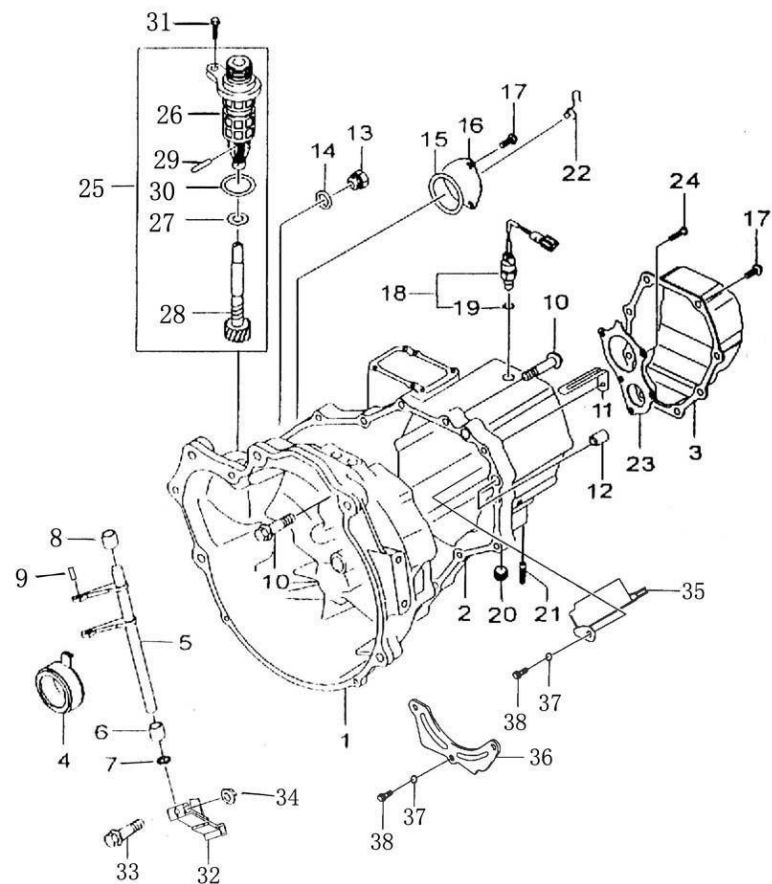

图1-14-5						
序号	零件序列号	零部件编号	名称	名称	数量	备注
No.	PART SERIAL NO.	Part No.	PART NAME	PART NAME	Qty	Rem.
1		5T07-170 2100	选、换挡轴 总成	Shaft comp., gear select & shift	1	7110
2	02.02.7110011 GHH465Q-2E	5T07-170 2101	选、换挡轴	Shaft, gear select & shift	1	7110
3		GB/T896 -1986	挡圈12	Retaining ring 12	2	7110
4		5T07-170 2102	轴套(左)	Bush, L.	1	7110
5		5T07-170 2103	弹簧	Spring	2	7110
6		5T07-170 2104	垫圈	Washer	1	7110
7		5T07-170 2107	换挡联锁 挡板	Guard, shift interlock	1	7110
8		5T07-170 2105	换挡臂	Shift arm	1	7110
9		GB/T879 -1986	销3.5×28	Pin 3.5×28	1	7110
10		5T07-170 2106	选档臂固 定销	Pin, gear select arm	1	7110

图1-14-5

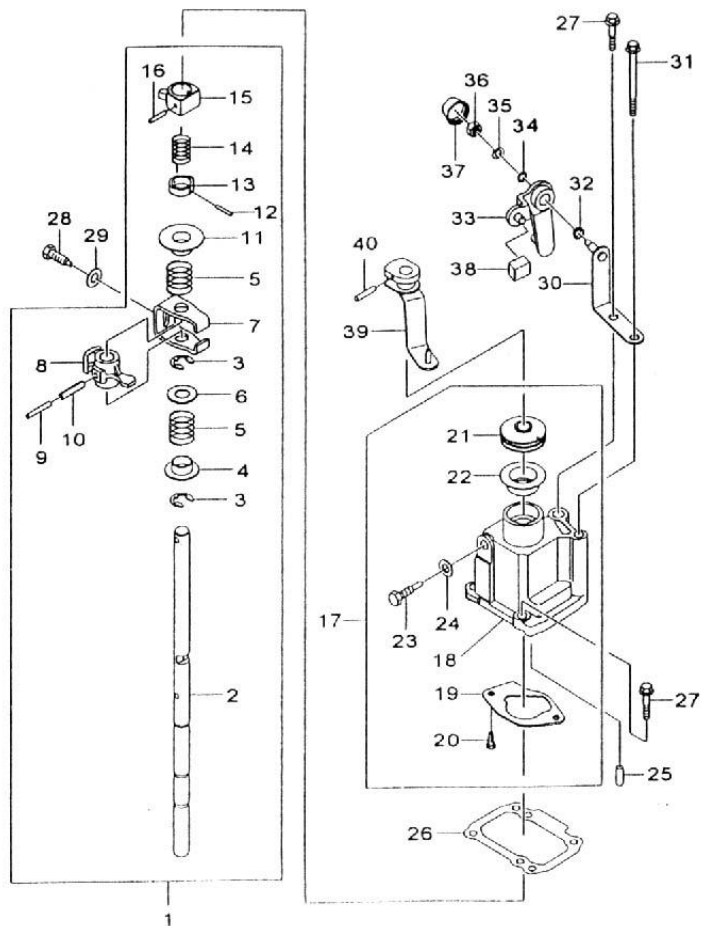

图1-14-5

序号 No.	零件序列号 PART SERIAL NO.	零部件编号 Part No.	名称 PART NAME	名称 PART NAME	数量 Qty	备注 Rem.
11		5T07-170 2112	轴套(右)	Bush, R.	1	7110
12		GB/T879 -1986	销3×22	Pin 3×22	1	7110
13		5T07-170 2108	倒档限位扭 簧定位套	Positioning sleeve, reverse gear shift limit coil spring	1	7110
14		5T07-170 2109	倒档限位扭 簧	Coil spring, reverse gear shift limit	1	7110
15		5T07-170 2111	倒档限位凸 轮	Cam, reverse gear shift limit	1	7110
16		GB/T879 -1986	销5×22	Pin 5×22	1	7110
17		5T07-170 2070	选、换档轴 导箱总成	Guide cage comp., gear select & shift shaft	1	7110
18	02.02.7110012 GHH465Q-2E	5T07-170 2071	选、换档轴 导箱	Guide cage, gear select & shift shaft	1	7110
19	02.02.7110013 GHH465Q-2E	5T07-170 2072	选、换档轴 导板	Guide plate, gear select & shift shaft	1	7110
20		GB/T578 9-1986	螺栓 AM6×12	Bolt AM6×12	2	7110

图1-14-5

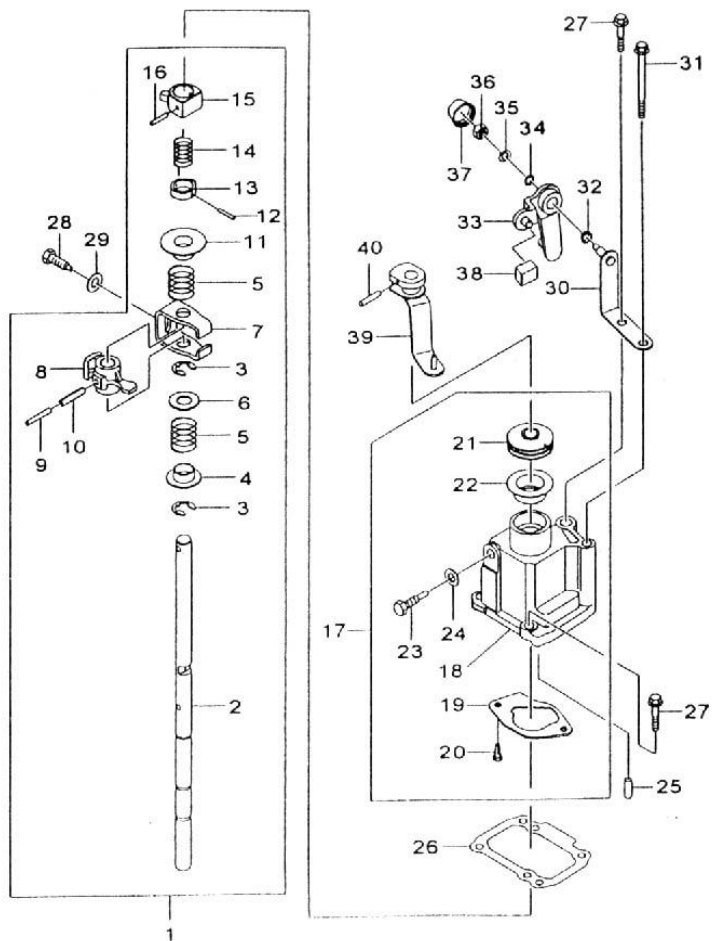

图1-14-5

序号 No.	零件序列号 PART SERIAL NO.	零部件编号 Part No.	名称 PART NAME	名称 PART NAME	数量 Qty	备注 Rem.
21	02.02.7110014 GHH465Q-2E	5T07-170 2062	选、换档轴 防尘罩	Dust boot, gear select & shift shaft	1	7110
22	02.02.7110015 GHH465Q-2E	5T07-170 2003	选、换档轴 防尘罩座	Seat, dust boot	1	7110
23	02.02.7110016 GHH465Q-2E	5T07-170 2073	倒档限位螺 栓	Bolt, reverse gear shift limit	1	7110
24	02.02.7110017 GHH465Q-2E	5T07-170 2052	限位螺栓垫 圈	Washer, limit bolt	1	7110
25		GB/T119 -1986	销B6×12	Pin B6×12	1	7110
26	02.02.7110018 GHH465Q-2E	5T07-170 2002	导箱密封垫	Gasket, guide cage seal	1	7110
27		GB/T578 9-1986	螺栓 AM8×25	Bolt AM8×25	4	7110
28	02.02.7110019 GHH465Q-2E	5T07-170 2065	换档限位螺 栓	Limit bolt, gear shift	1	7110
29	02.02.7110020 GHH465Q-2E	5T07-170 2066	限位螺栓垫 圈	Washer, limit bolt	11	7110
30	02.02.7110023 GHH465Q-2E	5T07-170 2220	选档转臂支 架组件	Bracket kit, gear select arm	1	7110

图1-14-5

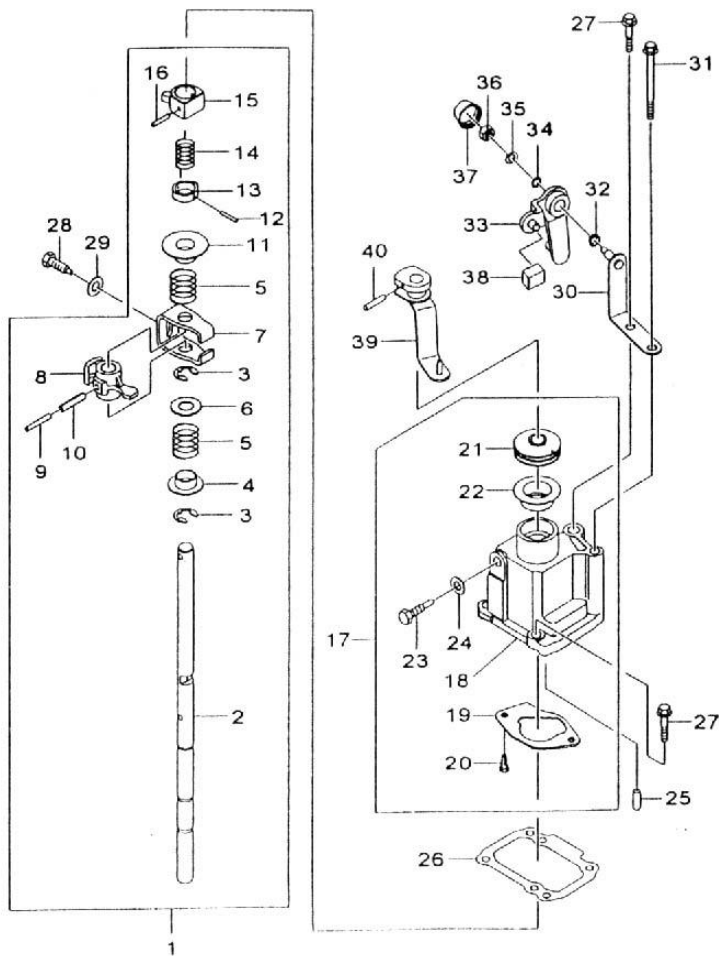

图1-14-5

序号 No.	零件序列号 PART SERIAL NO.	零部件编号 Part No.	名称 PART NAME	名称 PART NAME	数量 Qty	备注 Rem.
31		GB/T578 9-1986	螺栓 AM8×75	Bolt AM8×75	1	7110
32	02.02.7110024 GHH465Q-2E	5T07-170 2064	选档转臂 防尘垫	Dust-proof cushion, gear select arm	1	7110
33	02.02.7110025 GHH465Q-2E	5T07-170 2210	选档转臂 组件	Arm kit, gear select	1	7110
34	02.02.7110026 GHH465Q-2E	5T07-170 2045	选档转臂 小垫圈	Small washer, gear select arm	1	7110
35	02.02.7110027 GHH465Q-2E	5T07-170 2046	选档转臂 大垫圈	Big washer, gear select arm	1	7110
36	02.02.7110085 GHH465Q-2E	GB/T617 0-1986	螺母M8	Nut M8	1	7110
37		5T07-170 2047	选档转臂 防尘罩	Dust boot, gear select arm	1	7110
38	02.02.7110028 GHH465Q-2E	5T07-170 2063	选档拨块	Gear select gate	1	7110
39	02.02.7110029 GHH465Q-2E	5T07-170 2090	换档转臂 组件	Gear shift arm kit	1	7110
40		GB/T879 -1986	销5×28	Pin 5×28	1	7110

图1-15-1

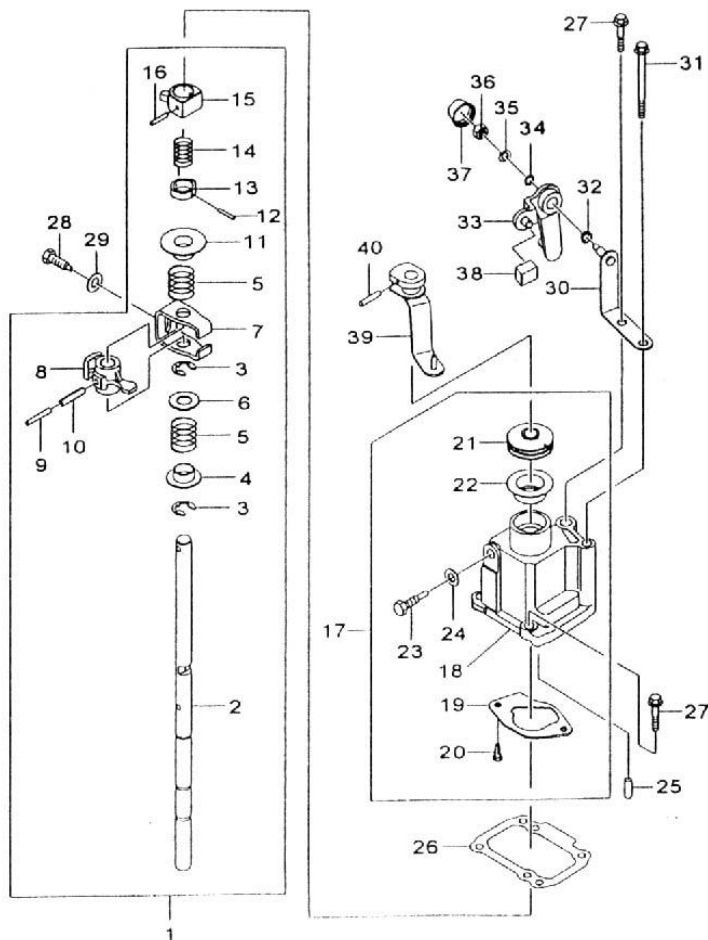

图1-15-1

序号 No.	零件序列号 PART SERIAL NO.	零部件编号 Part No.	名称 PART NAME	名称 PART NAME	数量 Qty	备注 Rem.
1	02.02.00BD001 GHH368QA1	1702014	一、二档换挡拨叉	Shift lever, gear 1# & 2#	1	BD
2	02.02.00BD002 GHH368QA1	1702013	一、二档换挡叉	Shift fork, gear 1# & 2#	1	BD
3	02.02.00BD003 GHH368QA1	1702015	三、四档换挡拨叉	Shift lever, gear 3# & 4#	1	BD
4	02.02.00BD004 GHH368QA1	1702012	倒档换挡叉	Shift fork, reverse gear	1	BD
5	02.02.00BD005 GHH368QA1	1702011	倒档换挡悬臂	Shift arm, reverse gear	1	BD
6	02.02.00BD006 GHH368QA1	1702060	倒档换挡拨叉总成	Shift lever comp., reverse gear	1	BD
7		GB/T578 3—1986	倒档换挡杆螺栓 M10×1.25×35	Bolt, reverse gear shift lever	1	BD
8		1702019	密封垫	Gasket	1	BD
9	02.02.00BD007 GHH368QA1	1702017	一、二档换挡叉轴	Shaft, shift fork, gear 1# & 2#	1	BD
10	02.02.00BD008 GHH368QA1	1702018	三、四档换挡叉轴	Shaft, shift fork, gear 3# & 4#	1	BD

图1-15-1

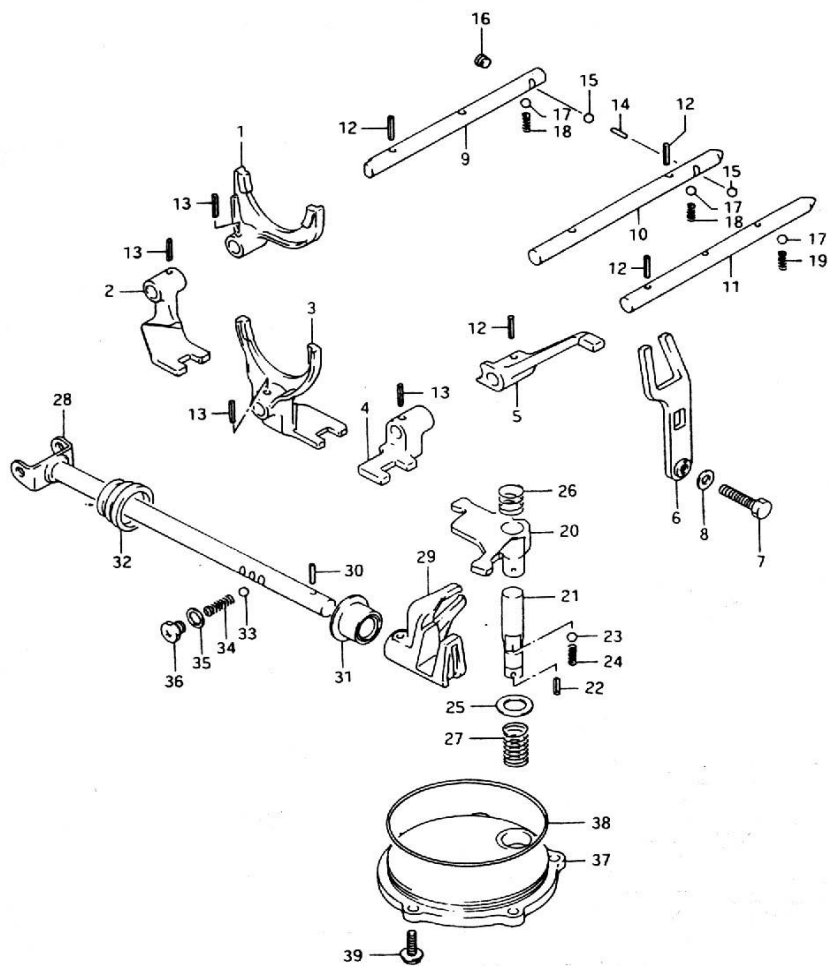

图1-15-1

序号 No.	零件序列号 PART SERIAL NO.	零部件编号 Part No.	名称 PART NAME	名称 PART NAME	数量 Qty	备注 Rem.
11	02.02.00BD009 GHH368QA1	1702016	倒档换挡叉轴	Shaft, shift fork, reverse gear	1	BD
12		GB/T859—1986	弹性销4.5×18	Spring pin 4.5×18	4	BD
13		GB/T859—1986	弹性销4.5×20	Spring pin 4.5×20	4	BD
14		GB/T309—1984	滚针3×9.8	Needle 3×9.8	1	BD
15	02.02.00BD010 GHH368QA1	GB/T308—1984	钢球(互锁) 9.5250G60b	Inter-lock steer ball 9.5250G60b	2	BD
16		1701021	塞	Plug	1	BD
17		GB/T308—1984	钢球(定位) 7.9375G60b	Steel ball (position)	3	BD
18	02.02.00BD011 GHH368QA1		压缩弹簧	Compression spring	2	BD
19		1702022	压缩弹簧	Compression spring	1	BD
20	02.02.00BD013 GHH368QA1	1702082	换挡臂	Shift arm	1	BD

图1-15-1

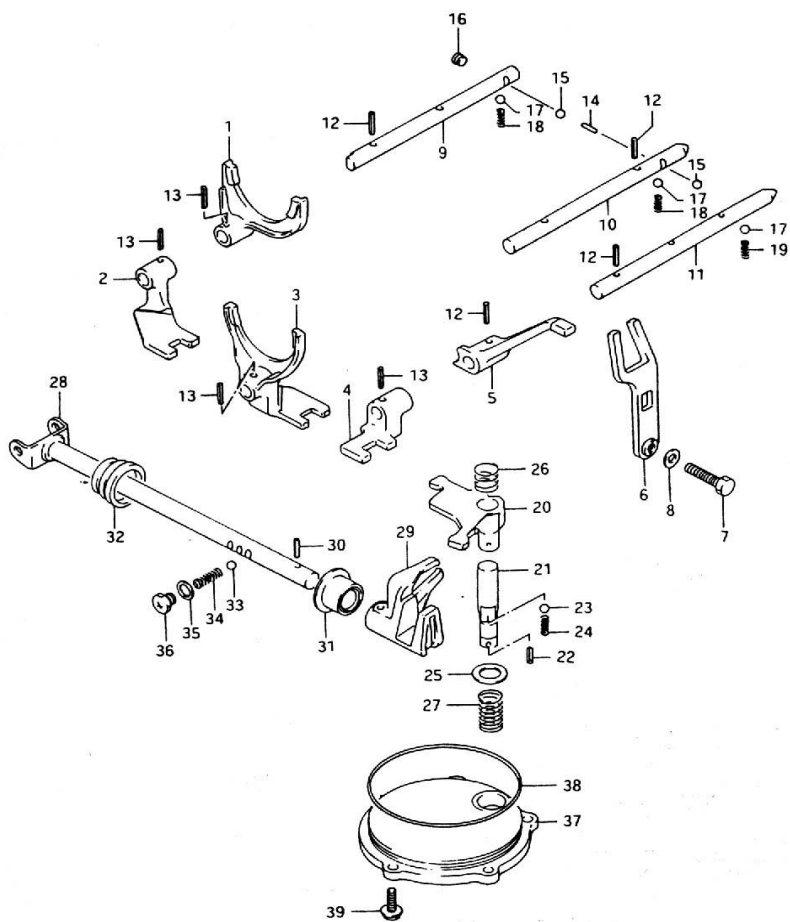

图1-15-1

序号 No.	零件序列号 PART SERIAL NO.	零部件编号 Part No.	名称 PART NAME	名称 PART NAME	数量 Qty	备注 Rem.
21	02.02.00BD014 GHH368QA1	1702081	换档臂轴	Shaft, shift arm	1	BD
22	02.02.00BD015 GHH368QA1	GB/T119 —1986	定位销 D4×8.5	Pin D4×8.5	1	BD
23	02.02.00BD016 GHH368QA1	GB/T308 —1984	钢球(定位) 7.9375G60b	Steel ball (position)	1	BD
24	02.02.00BD012 GHH368QA1	1702022	压缩弹簧	Compression spring	1	BD
25	02.02.00BD017 GHH368QA1	1702026	垫圈	Washer	1	BD
26	02.02.00BD018 GHH368QA1	1702024	压缩弹簧	Compression spring	1	BD
27	02.02.00BD019 GHH368QA1	1702025	压缩弹簧	Compression spring	1	BD
28	02.02.00BD020 GHH368QA1	1702070	换档轴总成	Gear shift shaft comp	1	BD
29	02.02.00BD021 GHH368QA1	1702028	换档叉	Shift fork	1	BD
30	02.02.00BD022 GHH368QA1	GB/T879 —1986	弹性销5×22	Spring pin 5×22	1	BD

图1-15-1

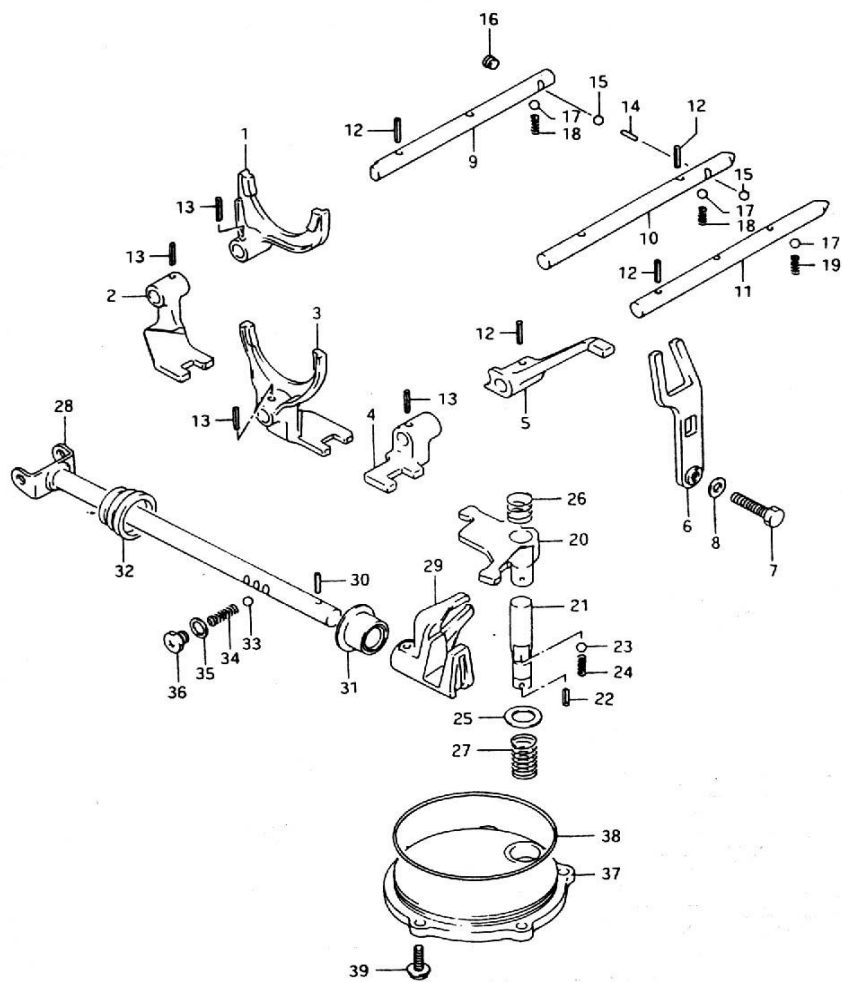

图1-15-1

序号 No.	零件序列号 PART SERIAL NO.	零部件编号 Part No.	名称 PART NAME	名称 PART NAME	数量 Qty	备注 Rem.
31		1702040	油封	Oil seal	1	BD
32	02.02.00BD024 GHH368QA1	1702027	换挡轴防尘盖	Dust cover, shift shaft	1	BD
33		GB/T308—1984	钢球 7.9375G60b	Steel ball 7.9375G60b	1	BD
34	02.02.00BD012 GHH368QA1	1702022	压缩弹簧	Compression spring	1	BD
35		1702019	密封垫	Gasket	1	BD
36			六角头十字螺栓 M10×1.25×9	Cross headed hex bolt M10×1.25×9	1	BD
37	02.02.00BD025 GHH368QA1	1702023	换挡臂轴盖	Cover, shift arm shaft	1	BD
38	02.02.00BD026 GHH368QA1	GB/T345 2.1—1992	圆形密封圈 95×2.65	O seal 95×2.65	1	BD
39		GB/T789—1986	螺栓 AM6×20	Bolt M6×20	5	BD

图1-15-4

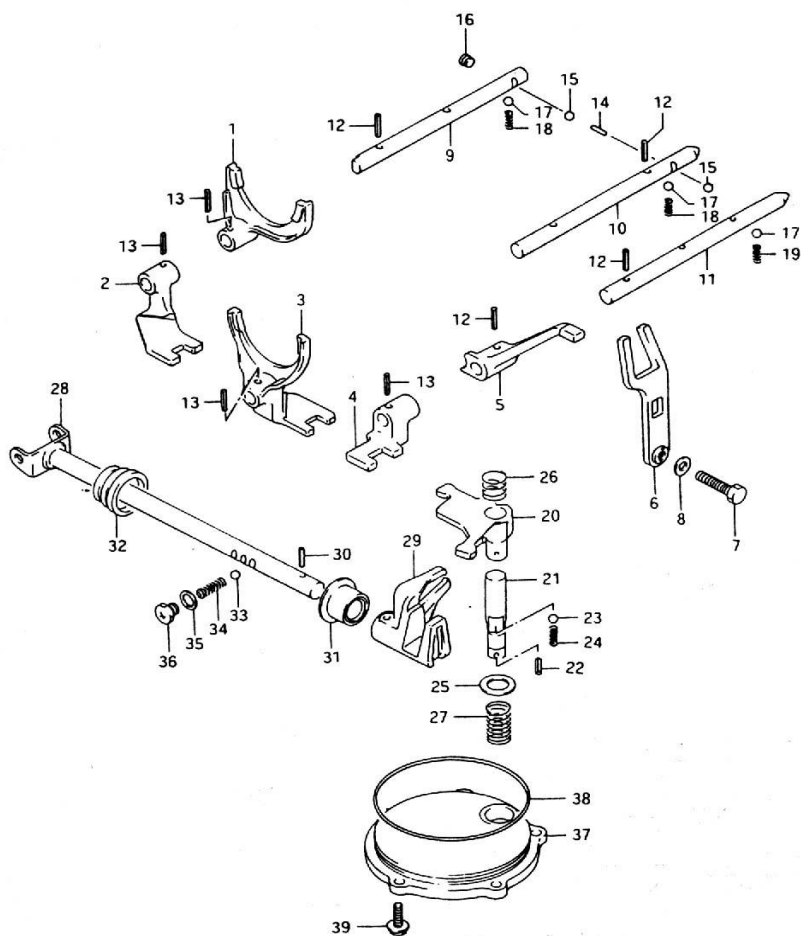

图1-15-4

序号 No.	零件序列号 PART SERIAL NO.	零部件编号 Part No.	名称 PART NAME	名称 PART NAME	数量 Qty	备注 Rem.
1	02.02.7110030 GHH465Q-2E	5T07-170 2048	一、二档换挡拨叉	Shift lever, gear 1# & 2#	1	7110
2	02.02.7110031 GHH465Q-2E	5T07-170 2041	三、四档换挡拨叉	Shift lever, gear 3# & 4#	1	7110
3		GB/T308 -1984	钢球 7.9375	Steel ball 7.9375	4	7110
4	02.02.7110032 GHH465Q-2E	5T07-170 2042	倒档换挡叉	Shift fork, reverse gear	1	7110
5	02.02.7110033 GHH465Q-2E	5T07-170 2061	三、四档换挡叉	Shift fork, gear 3# & 4#	1	7110
6	02.02.7110034 GHH465Q-2E	5T07-170 2049	一、二档换挡叉	Shift fork, gear 1# & 2#	1	7110
7	7110	GB/T879 -1986	销4.5×20	Pin, 4.5×20	6	7110
8	7110 02.02.7110035 GHH465Q-2E	5T07-170 2044	一、二档换挡杆	Shift rod, gear 1# & 2#	1	7110
9	02.02.7110036 GHH465Q-2E	5T07-170 2067	换挡杆锁紧弹簧	Retaining spring, shift rod	2	7110
10	02.02.7110037 GHH465Q-2E	5T07-170 2009	三、四档换挡杆	Shift rod, gear 3# & 4#	1	7110

图1-15-4

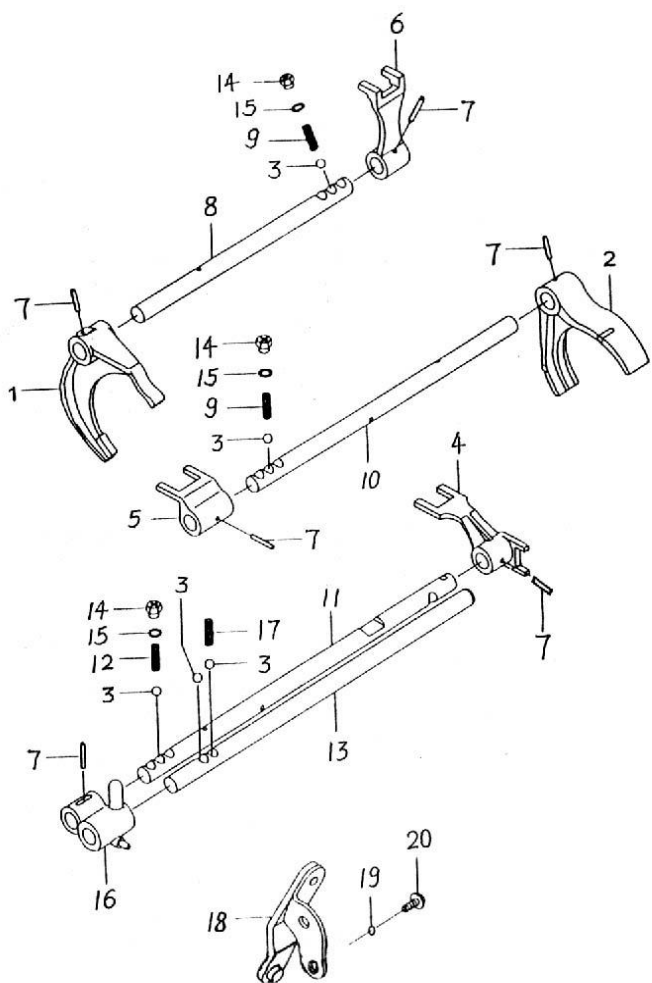

图1-15-4

序号 No.	零件序列号 PART SERIAL NO.	零部件编号 Part No.	名称 PART NAME	名称 PART NAME	数量 Qty	备注 Rem.
11	02.02.7110038 GHH465Q-2E	4T08-170 2002	倒档换挡杆	Shift rod, reverse gear	1	7110
12	02.02.7110039 GHH465Q-2E	5T07-170 2069	倒档换挡杆锁紧弹簧	Retaining spring, reverse gear shift rod	1	7110
13	02.02.7110040 GHH465Q-2E	4T08-170 2001	倒档换挡导杆	Guidero, reverse gear shift	1	7110
14		ZBT3103 3-1988	螺栓 M10×1.25×9	Bolt M10×1.25×9	3	7110
15	02.02.7110089 GHH465Q-2E	GB/T848 -1985	垫圈 10-140HV	Washer 10-140HV	3	7110
16	02.02.7110041 GHH465Q-2E	5T07-170 2043	倒档换挡拨块	Shift gate, reverse gear shift	1	7110
17	02.02.7110042 GHH465Q-2E	5T07-170 2068	倒档换挡拨块锁紧弹簧	Retaining spring, reverse gear shift gate	1	7110
18	02.02.7110043 GHH465Q-2E	5T07-170 2050	倒档换挡臂组件	Arm kit, reverse gear shift	1	7110
19	02.02.7110087 GHH465Q-2E	GB/T724 6-1987	垫圈8	Washer 8	2	7110
20		GB/T578 1-1986	螺栓M8×20	Bolt M8×20	2	7110

图1-16-1

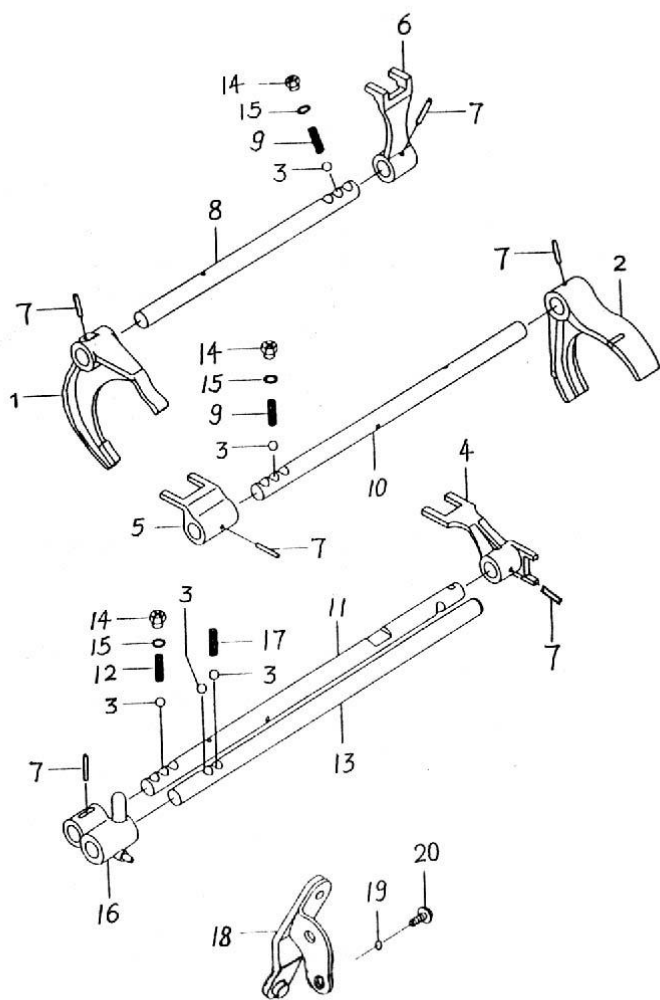

图1-16-1

序号 No.	零件序列号 PART SERIAL NO.	零部件编号 Part No.	名称 PART NAME	名称 PART NAME	数量 Qty	备注 Rem.
1	02.03.00BD002 GHH368QA1	2303017	差速器行星 齿轮	Pinion, differential	2	BD
2	02.03.00BD003 GHH368QA1	2303015	差动齿轮	Differential gear	2	BD
3	02.03.00BD005 GHH368QA1	2303019	行星齿轮轴	Shaft, planetary gear	1	BD
4		GB/T309 —1984	销D5×25.8	Pin D5×25.8	1	BD
5	02.03.00BD004 GHH368QA1	2303018	行星齿轮垫 圈	Washer, planetary gear	2	BD
6	02.03.00BD006 GHH368QA1	2303012	半轴调整垫 圈	Adjusting washer, axle shaft	2	BD
7	02.03.00BD007 GHH368QA1	2303011	差速器壳	Housing, differential	1	BD
8	02.03.00BD008 GHH368QA1	2303021	主减速齿轮	Gear, final drive	1	BD
9		GB/T578 9—1986	螺栓 M10×1.25× 20—10.9	Bolt M10×1.25×20 —10.9	8	BD
10	02.03.00BD009 GHH368QA1	GB/T276 —1994	轴承 3G60207	Bearing 3G60207	2	BD
11	02.03.00BD010 GHH368QA1	1701090	油封	Oil seal	2	BD
12	02.03.00BD011 GHH368QA1	1701014	C形环	C ring	2	BD
13	02.02.00BD087 GHH368QA1	2303016	钢丝挡圈	Steel thread retaining ring	2	BD

图1-16-4

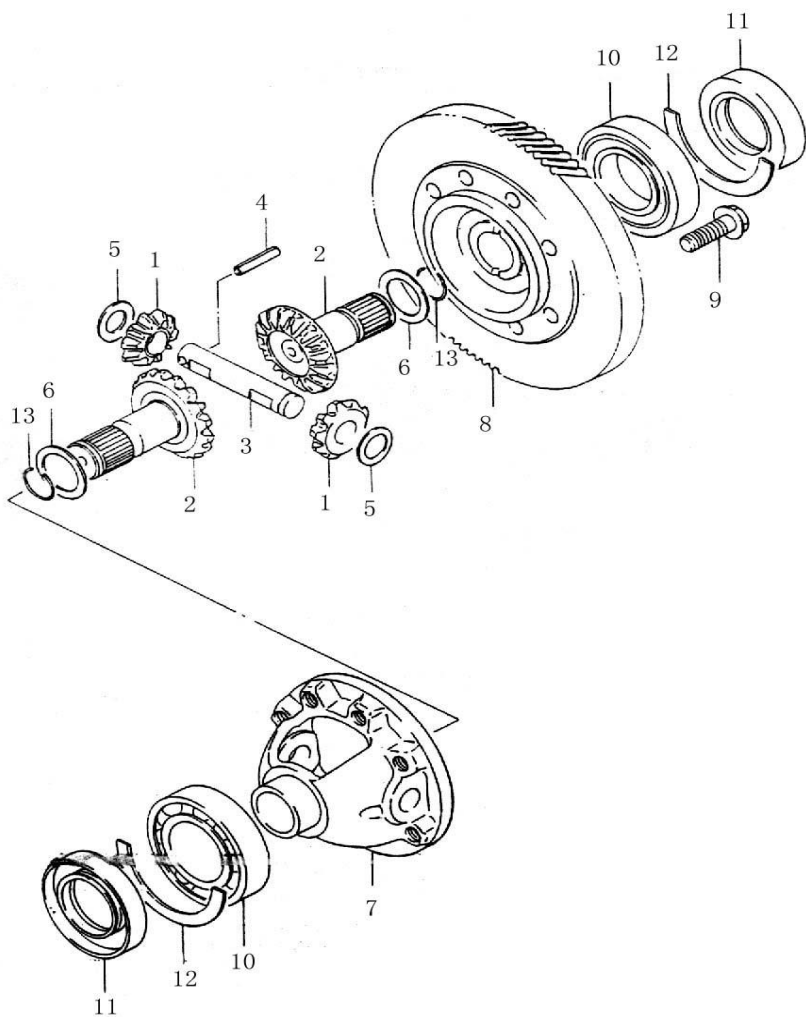

图1-16-4

序号 No.	零件序列号 PART SERIAL NO.	零部件编号 Part No.	名称 PART NAME	名称 PART NAME	数量 Qty.	备注 Rem.
1	02.03.7110001G HH465Q-2E	5T07-170 1308	差速器壳体	House, differential	1	7110
2	02.03.7110002G HH465Q-2E	5T07-170 1301	主减速齿轮	Gear, final drive	1	7110
3	02.03.7110003G HH465Q-2E	5T07-170 1010	差速器密封 圈总成(左)	Seal comp., differential, L.	1	7110
4	02.02.7110103G HH465Q-2E	GB/T276- 1994	轴承 6207/P63	Bearing 6207/P63	2	7110
5	02.03.7110004G HH465Q-2E	5T07-170 1307	速度计主动 齿轮	Driving gear, speedometer	1	7110
6		GB/T879- 1986	销5×36	Pin 5×36	1	7110
7	02.03.7110005G HH465Q-2E	5T07-170 1090	差速器密封 圈总成(右)	Seal comp., differential, R.	1	7110
8		GB/T5787 -1986	螺栓 AM10×1.25× 23-10.9	Bolt AM10×1.25×23 -10.9	8	7110
9	02.03.7110006G HH465Q-2E	5T07-170 1303	行星齿轮轴	Shaft, Planetary gear	1	7110
10	02.03.7110007G HH465Q-2E	5T07-170 1304	行星齿轮	Planetary gear, differential	2	7110
11	02.03.7110009G HH465Q-2E	5T07-170 1305	半轴齿轮	Gear, axle shaft	2	7110
12	02.03.7110008G HH465Q-2E	5T07-170 1302	行星齿轮垫 片	Washer, planetary gear	2	7110
13	02.03.7110011G HH465Q-2E	5T07-170 1306	半轴齿轮垫 片	Gear, axle shaft gear	2	7110
14	02.03.7110010G HH465Q-2E	5T07-170 1300	差速器总成	Differential comp.	1	7110

图1-17-1

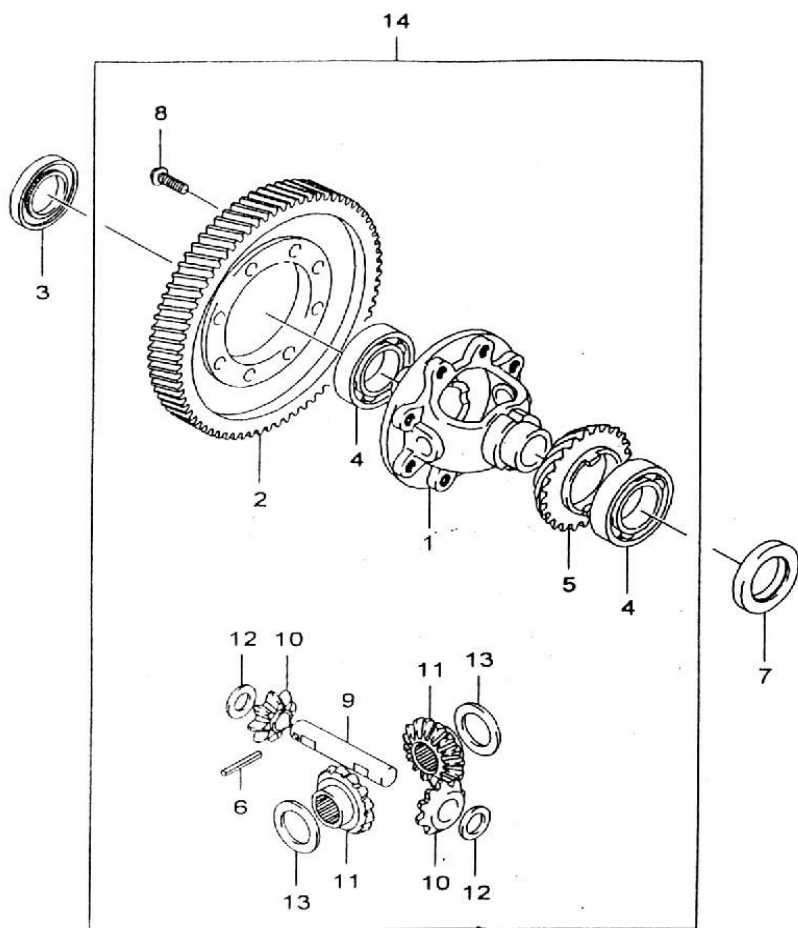

图1-17-1

序号 No.	零件序列号 PART SERIAL NO.	零部件编号 Part No.	名称 PART NAME	名称 PART NAME	数量 Qty	备注 Rem.
1	14.01.00BD001 GHH368QA1	3708010	起动机总成	Starter comp.	1	BD
2			起动机机壳总成	House comp., start	1	BD
3			轴承	Bearing	1	BD
4	14.01.00BD002 GHH368QA1		磁力开关总成	Magnetic switch comp.	1	BD
5			柱塞盖	Cover, plunger	1	BD
6			螺母	Bolt	2	BD
7			起动机驱动杆	Driving rod, starter	1	BD
8			起动机密封圈	Seal, starter	1	BD
9			螺母	Nut	1	BD
10			弹簧垫圈	Spring washer	1	BD
11			六角螺母	Hex-angle nut	1	BD
12			垫圈	Washer	1	BD

图1-17-1

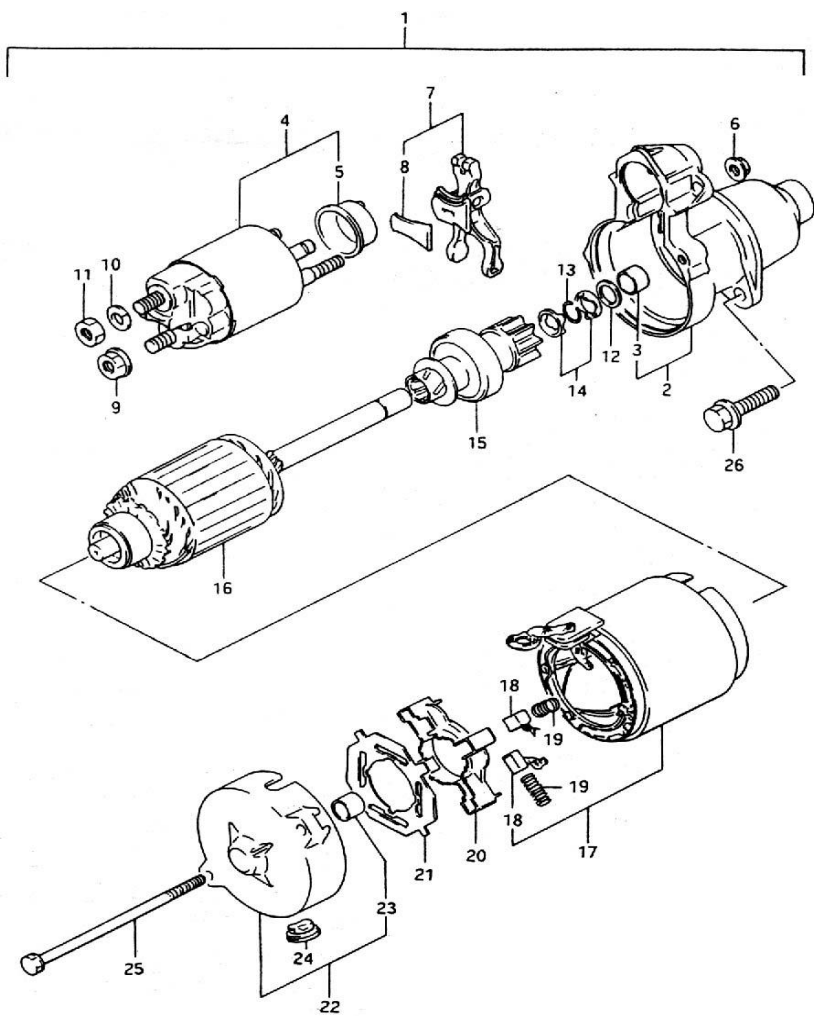

图1-17-1						
序号	零件序列号	零部件编号	名称	名称	数量	备注
No.	PART SERIAL NO.	Part No.	PART NAME	PART NAME	Qty	Rem.
13			卡口环	Snap ring	1	BD
14			小齿轮限位螺母	Retaining nut, pinion	1	BD
15			起动机离合器总成	Clutch comp., starter	1	BD
16			起动机电枢总成	Armature comp.,	1	BD
17			起动机轭总成	Yoke comp., starter	1	BD
18			起动机套线	Cable, starter	4	BD
19			电刷弹簧	Spring, brush	4	BD
20			电刷架	Brush holder	1	BD
21			绝缘体	Insulator	1	BD
22			换向器端盖总成	End frame comp., commutator	1	BD
23			轴承	Bearing	1	BD
24			塞	Plug	1	BD
25			螺栓	Bolt	2	BD
26			螺栓	bolt	2	BD

图1-18-1

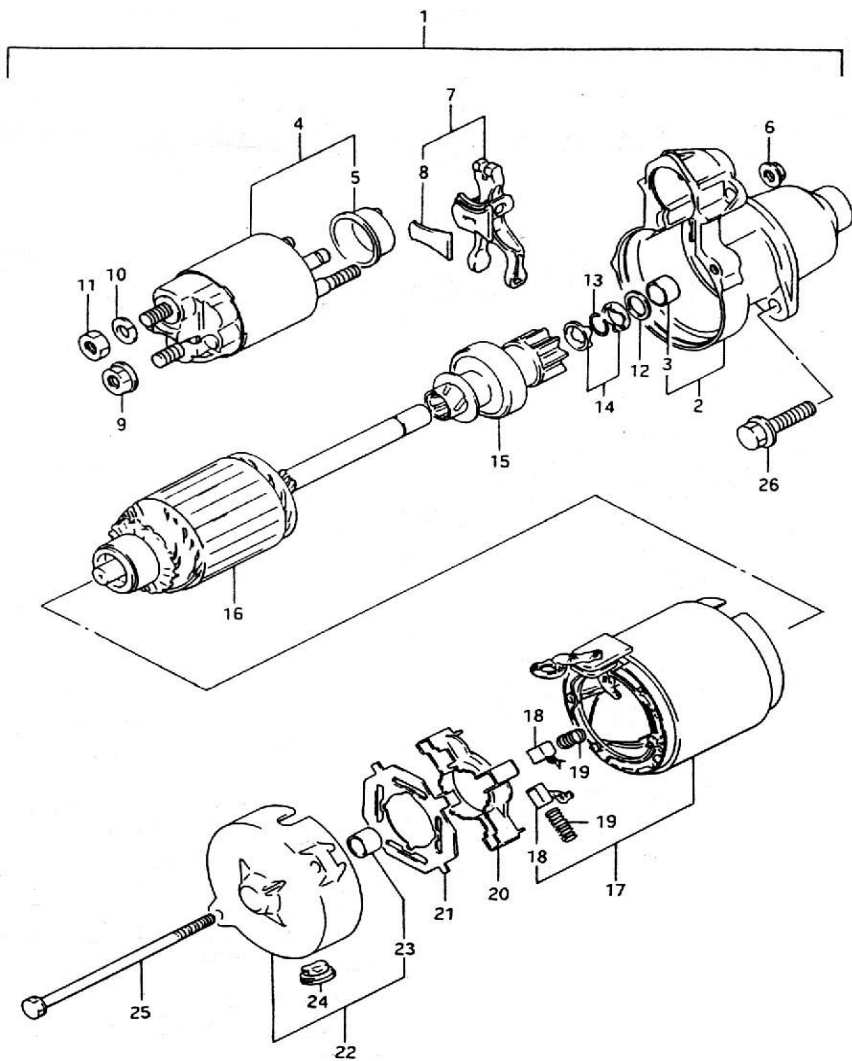

图1-18-1						
序号	零件序列号	零部件编号	名称	名称	数量	备注
No.	PART SERIAL NO.	Part No.	PART NAME	PART NAME	Qty	Rem.
1	13.01.00 BD001G	3701010	发电机总成	Generator comp.	1	BD
2			发电机皮带轮总成	Pulley comp., generator	1	BD
3			发电机皮带轮螺母	Nut, generator pulley	1	BD
4			发电机壳螺栓	Bolt, generator house	1	BD
5			轴承（前）	Bearing, F. R.	1	BD
6			转子	Rotor	1	BD
7			轴承（后）	Bearing, R.R.	1	BD
8			发电机调节器总成	Regulator comp., generator	1	BD
9			发电机电刷	Brush, generator	2	BD
10			发电机电刷弹簧	Spring, generator brush	2	BD
11			发电机整流器	Rectifier, generator	1	BD

图1-18-1

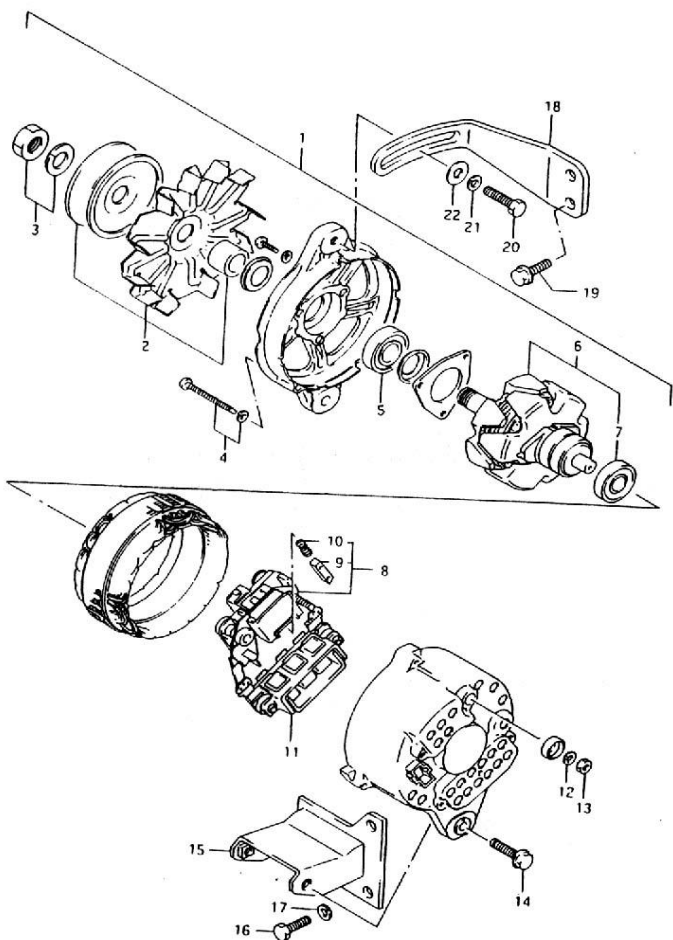

图1-18-1						
序号	零件序列号	零部件编号	名称	名称	数量	备注
No.	PART SERIAL NO.	Part No.	PART NAME	PART NAME	Qty	Rem.
12			垫圈	Washer	1	BD
13			螺母	Nut	1	BD
14			带肩螺栓	Bolt W/T flange	2	BD
15	13.01.00 BD003G	1000021	发电机支架	Bracket, generator	1	BD
16			螺栓	Bolt	3	BD
17			垫圈	Washer	3	BD
18		3701013	发电机皮带调节臂	Adjustment arm, generator belt	1	BD
19			带肩螺栓	Bolt W/T flange	2	BD
20			螺栓	Bolt	1	BD
21			弹垫	Spring washer	1	BD
22			垫圈	Washer	1	BD

图1-19-1

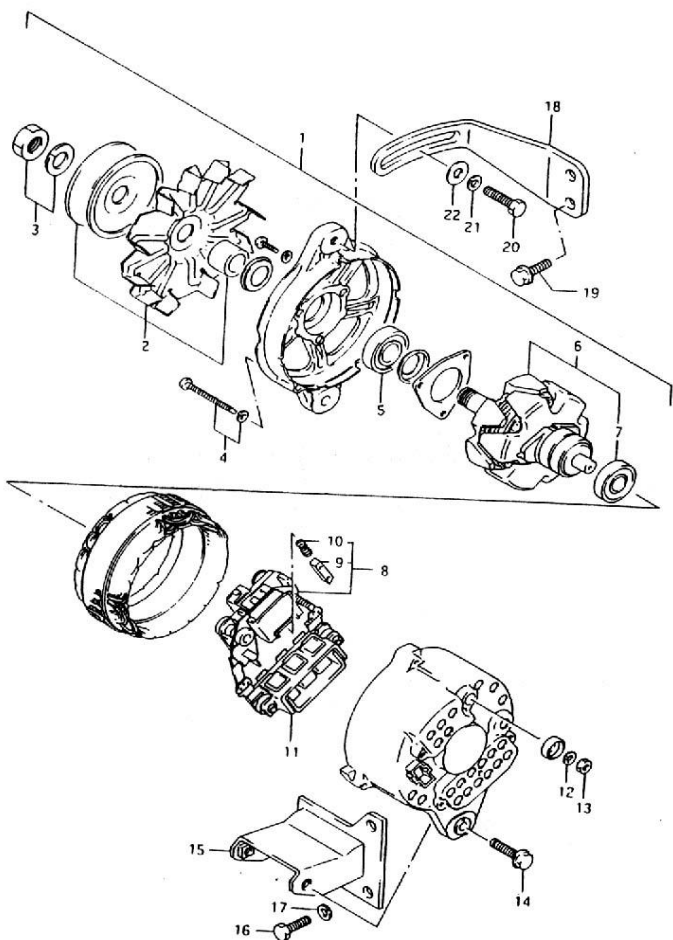

图1-19-1						
序号	零件序列号	零部件编号	名称	名称	数量	备注
No.	PART SERIAL NO.	Part No.	PART NAME	PART NAME	Qty	Rem
1	12.01.00 BD003G	3706010E	分电器总成	Distributor comp.	1	BD
2			螺钉总成	Screw comp.	2	BD
3	12.01.00 BD006G	3707012E	1# 高压阻尼线总成	High tension cable comp. 1#	1	BD
4	12.01.00 BD006G	3707012E	2# 高压阻尼线总成	High tension cable comp. 2#	1	BD
5	12.01.00 BD006G	3707012E	3# 高压阻尼线总成	High tension cable comp. 3#	1	BD
6		3707011E	0缸高压阻尼线总成	Kit 1#, high tension cable	1	BD
7	12.01.00 BD010G	3705010E	点火线圈总成	Ignition coil comp.	1	BD

图1-19-3

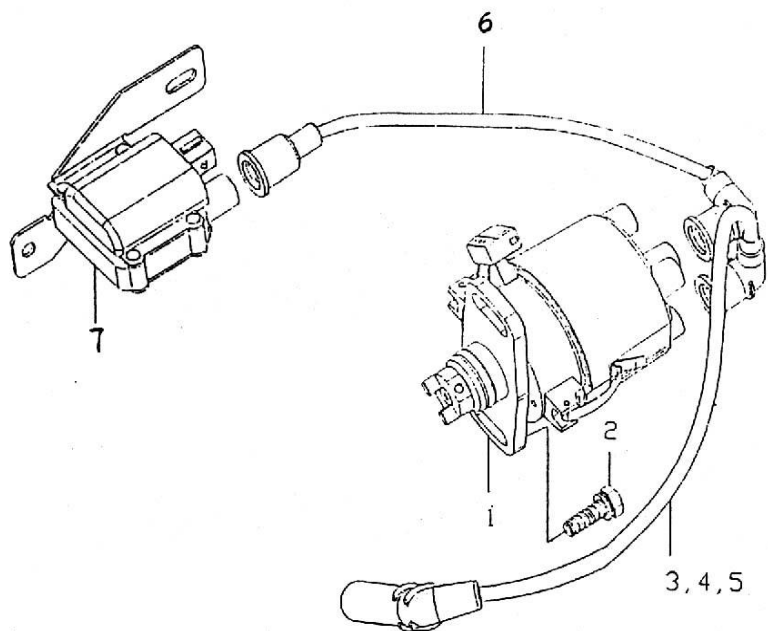

图1-19-3						
序号	零件序列号	零部件编号	名称	名称	数量	备注
No.	PART SERIAL NO.	Part No.	PART NAME	PART NAME	Qty	Rem.
1	01.07.00BD001 GHH368QA1		右支架软垫 总成	Cushion comp., brace, R.	1	BD
2		Q40110	垫圈10	Washer 10	1	BD
3		Q40410	弹垫10	Spring washer 10	2	BD
4		Q351C10	螺母 M10×1.25	Nut M10×1.25	2	BD
5	01.07.00BD002 GHH368QA1		右支架托架	Bracket, brace, R.	1	BD
6		Q150B08 20	螺栓M8×20	Bolt M8×20	4	BD
7		Q40408	弹垫8	Spring washer 8	4	BD
8	01.07.00BD003 GHH368QA1		右支架托架 加强板总成	Reinforcement comp., bracket, R. brace	1	BD
9		Q150B08 20	螺栓M8×20	Bolt M8×20	2	BD
10		Q40408	弹垫8	Spring washer 8	2	BD
11		1001040	发动机托架 总成	Engine bracket comp.	1	BD

图1-19-3

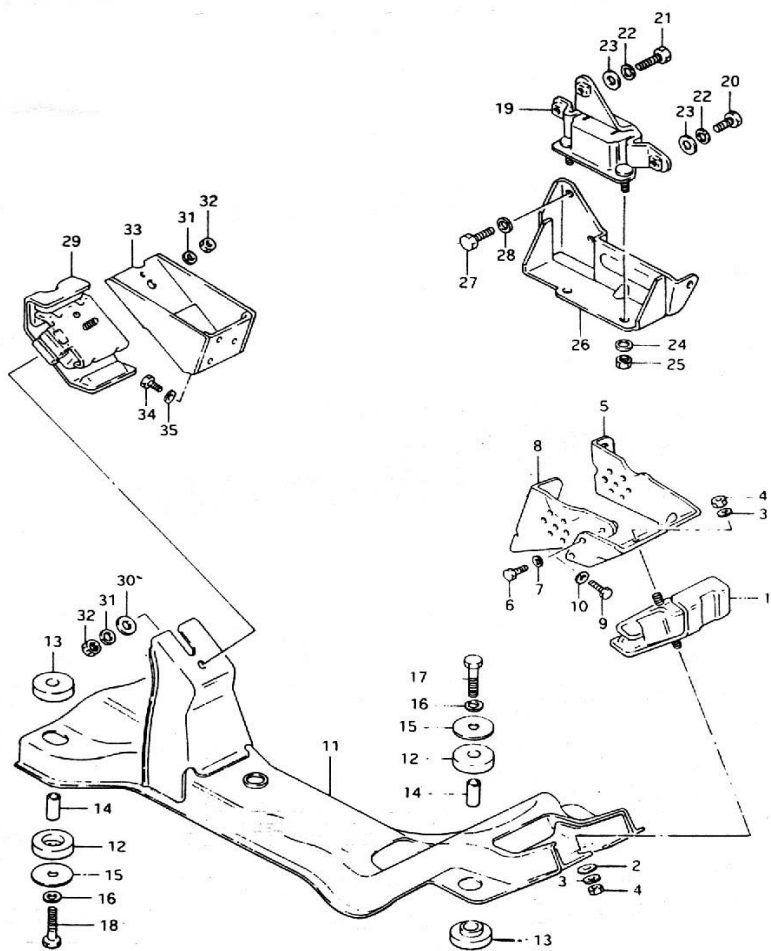

图1-19-3

序号	零件序列号	零部件编号	名称	名称	数量	备注
No.	PART SERIAL NO.	Part No.	PART NAME	PART NAME	Qty	Rem.
12	01.07.00 TY001G	8200962	上缓冲垫	Buffer cushion, Upper	4	BD
13	01.07.00 TY003G	8200961	下缓冲垫	Buffer cushion, Lower	4	BD
14		8200964	隔套	Distance sleeve	4	BD
15		8200963	垫圈	Washer	4	BD
16		Q40410	弹垫10	Spring washer 10	4	BD
17		Q151C10 55	螺栓 M10×1.25×55	Bolt M10×1.25×55	2	BD
18		Q151C10 55	螺栓 M10×1.25×55	Bolt M10×1.25×55	2	BD
19	01.07.00 BD004G HH368Q A1	1001052	后支架软垫总成	Cushion comp., brace, R. R.	1	BD
20		Q151C10 25	螺栓 M10×1.25×25	Bolt M10×1.25×25	2	BD
21		Q151C10 35	螺栓 M10×1.25×35	Bolt M10×1.25×35	1	BD
22		Q40410	弹垫10	Spring washer 10	3	BD
23		Q40110	垫圈10	Washer 10	3	BD

图1-19-3

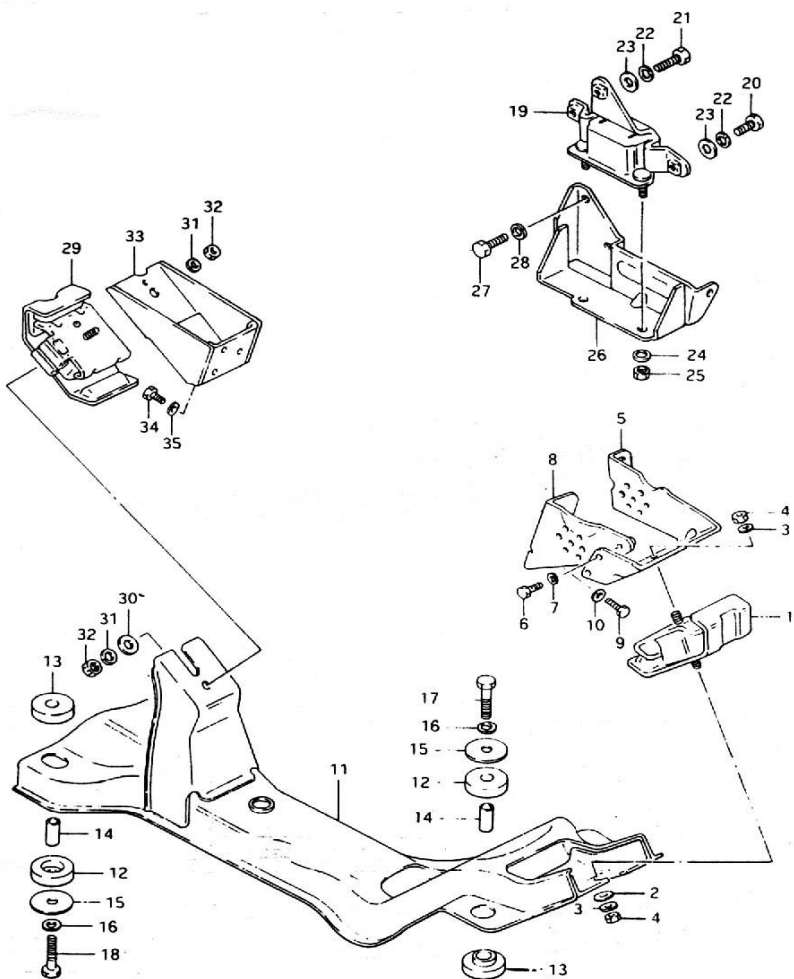

图1-19-3

序号 No.	零件序列号 PART SERIAL NO.	零部件编号 Part No.	名称 PART NAME	名称 PART NAME	数量 Qty	备注 Rem
24		Q40410	弹垫10	Spring washer 10	2	BD
25		Q341C10	螺母 M10×1.25	Nut M10×1.25	2	BD
26	01.07.00BD005 GHH368QA1	1001050	后支架托架 总成	Bracket comp., brace, R.R.	1	BD
27		Q151C102 5	螺栓 M10×1.25 ×25	Bolt M10×1.25×25	3	BD
28		Q40410	弹垫10	Spring washer 10	3	BD
29	01.07.00BD006 GHH368QA1	1001034	左支架软垫 总成	Cushion comp., brace, L.	1	BD
30		Q40110	垫圈10	Washer 10	1	BD
31		Q40410	弹垫10	Spring washer 10	2	BD
32		Q341C10	螺母 M10×1.25	Nut M10×1.25	2	BD
33	01.07.00BD007 GHH368QA1	1001031	左支架托架 总成	Bracket comp., brace, L.	1	BD
34		Q150B082 0	螺栓 M8×20	Bolt M8×20	3	BD
35		Q40408	弹垫8	Spring washer 8	3	BD

图1-20-3

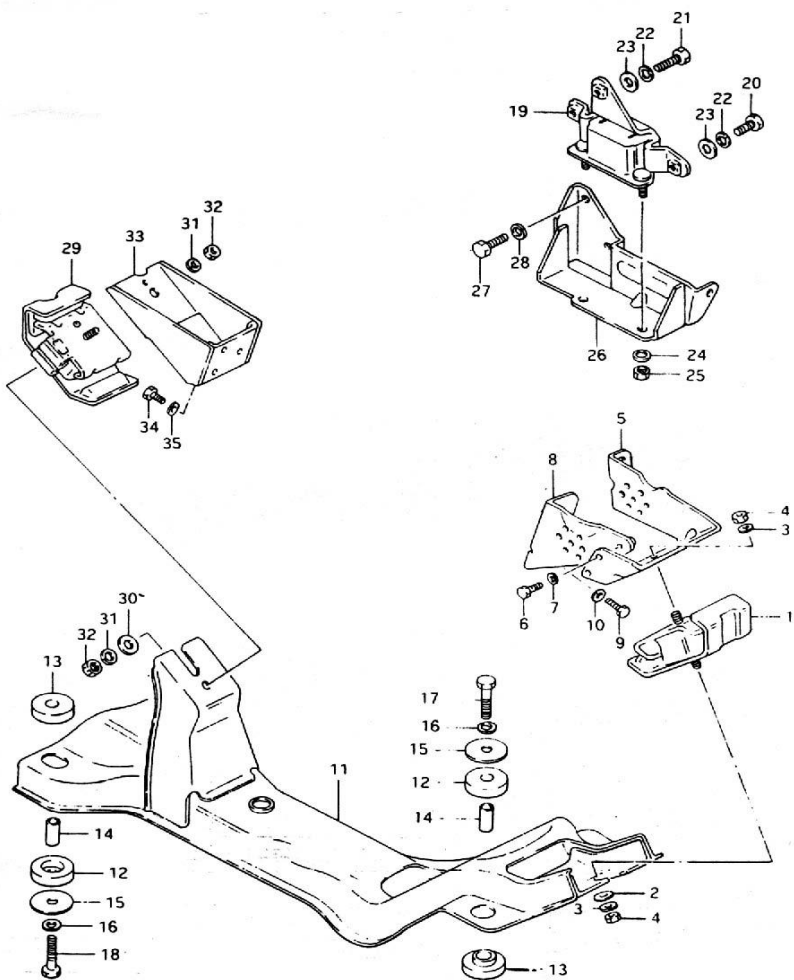

图1-20-3						
序号	零件序列号	零部件编号	名称	名称	数量	备注
No.	PART SERIAL NO.	Part No.	PART NAME	PART NAME	Qty	Rem.
1			右支架软垫总成	Cushion comp., brace, R.	1	7110
2		Q40110	垫圈10	Washer 10	1	7110
3		Q40410	弹垫10	Spring washer 10	2	7110
4		Q351C10	螺母 M10×1.25	Nut M10×1.25	2	7110
5	01.07.7110002 GHH465Q-2E		右支架托架	Bracket, brace, R.	1	7110
6		Q150B0820	螺栓M8×20	Bolt M8×20	4	7110
7		Q40408	弹垫8	Spring washer 8	4	7110
8			右支架托架加强板总成	Reinforcement comp., bracket, R. brace	1	7110
9		Q150B0820	螺栓M8×20	Bolt M8×20	2	7110
10		Q40408	弹垫8	Spring washer 8	2	7110
11		1001040-10	发动机托架总成	Engine bracket comp.	1	7110
12	01.07.00TY004 G	8200962	上缓冲垫	Buffer cushion, Upper	4	7110

图1-20-3

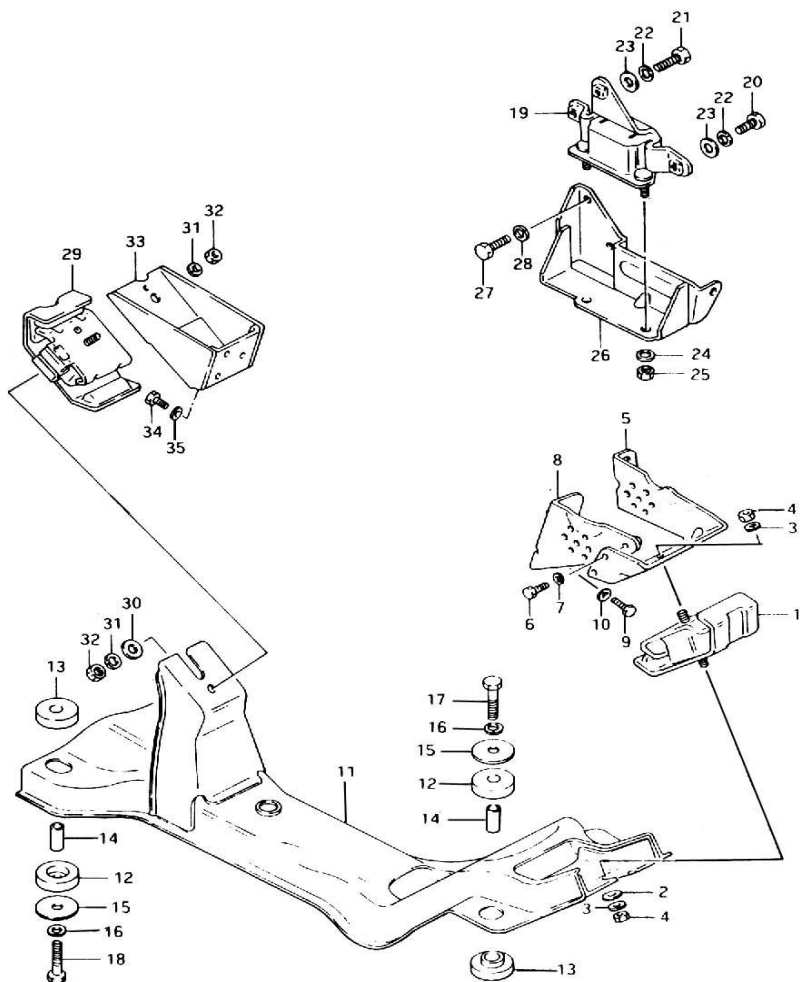

图1-20-3						
序号	零件序列号	零部件编号	名称	名称	数量	备注
No.	PART SERIAL NO.	Part No.	PART NAME	PART NAME	Qty	Rem.
13	01.07.00T Y003G	8200961	下缓冲垫	Buffer cushion, Lower	4	7110
14		8200964	隔套	Distance sleeve	4	7110
15		8200963	垫圈	Washer	4	7110
16		Q40410	弹垫10	Spring washer 10	4	7110
17		Q151C1055	螺栓 M10×1.25×55	Bolt M10×1.25×55	2	7110
18		Q151C1056	螺栓 M10×1.25×56	Bolt M10×1.25×56	2	7110
19	01.07.7110 004GHH4 65Q-2E	1001052-03	后支架软垫总成	Cushion comp., brace, R. R.	1	7110
20		Q151C1025	螺栓 M10×1.25×25	Bolt M10×1.25×25	2	7110
21		Q151C1035	螺栓 M10×1.25×35	Bolt M10×1.25×35	1	7110
22		Q40410	弹垫10	Spring washer 10	3	7110
23		Q40110	垫圈10	Washer 10	3	7110
24		Q40410	弹垫10	Spring washer 10	2	7110

图1-20-3

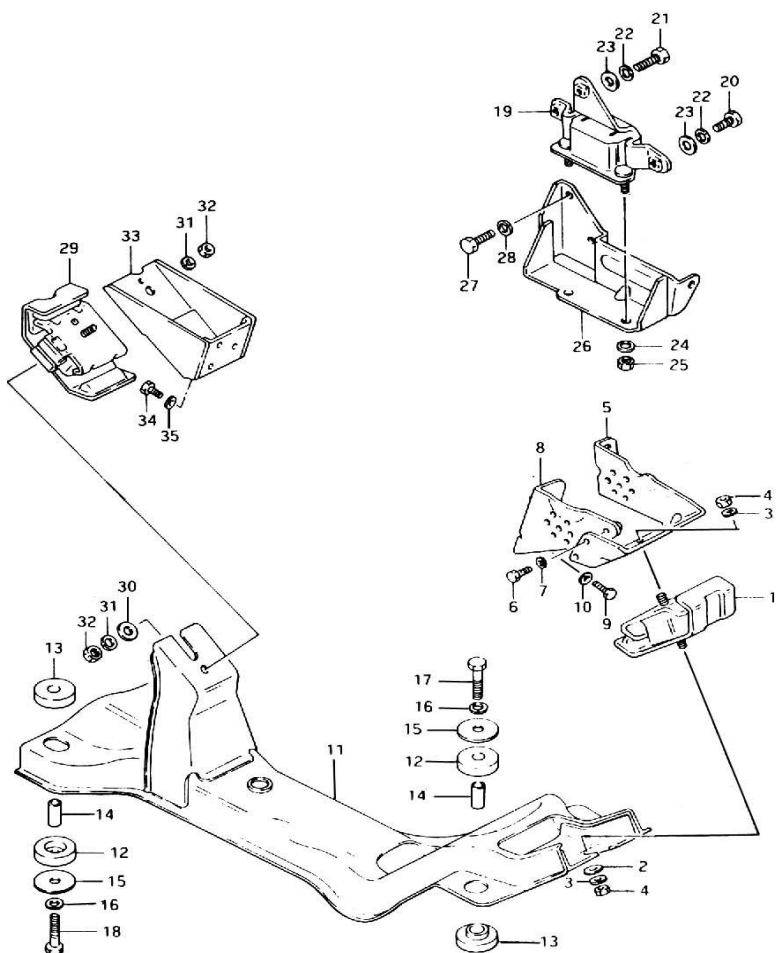

图1-20-3

序号 No.	零件序列号 PART SERIAL NO.	零部件编号 Part No.	名称 PART NAME	名称 PART NAME	数量 Qty	备注 Rem.
25		Q341C10	螺母 M10×1.25	Nut M10×1.25	2	7110
26	01.07.7110005 GHH465Q-2E	1001050-10	后支架托架总成	Bracket comp., brace, R.R.	1	7110
27		Q151C1025	螺栓 M10×1.25 ×25	Bolt M10×1.25×25	3	7110
28		Q40410	弹垫10	Spring washer 10	3	7110
29	01.07.7110006 GHH465Q-2E	1001034-03	左支架软垫总成	Cushion comp., brace, L.	1	7110
30		Q40110	垫圈10	Washer 10	1	7110
31		Q40410	弹垫10	Spring washer 10	2	7110
32		Q341C10	螺母 M10×1.25	Nut M10×1.25	2	7110
33	01.07.7110007 GHH465Q-2E	1001031-10	左支架托架总成	Bracket comp., brace, L.	1	7110
34		Q150B0820	螺栓 M8×20	Bolt M8×20	3	7110
35		Q40408	弹垫8	Spring washer 8	3	7110

图1-21-1

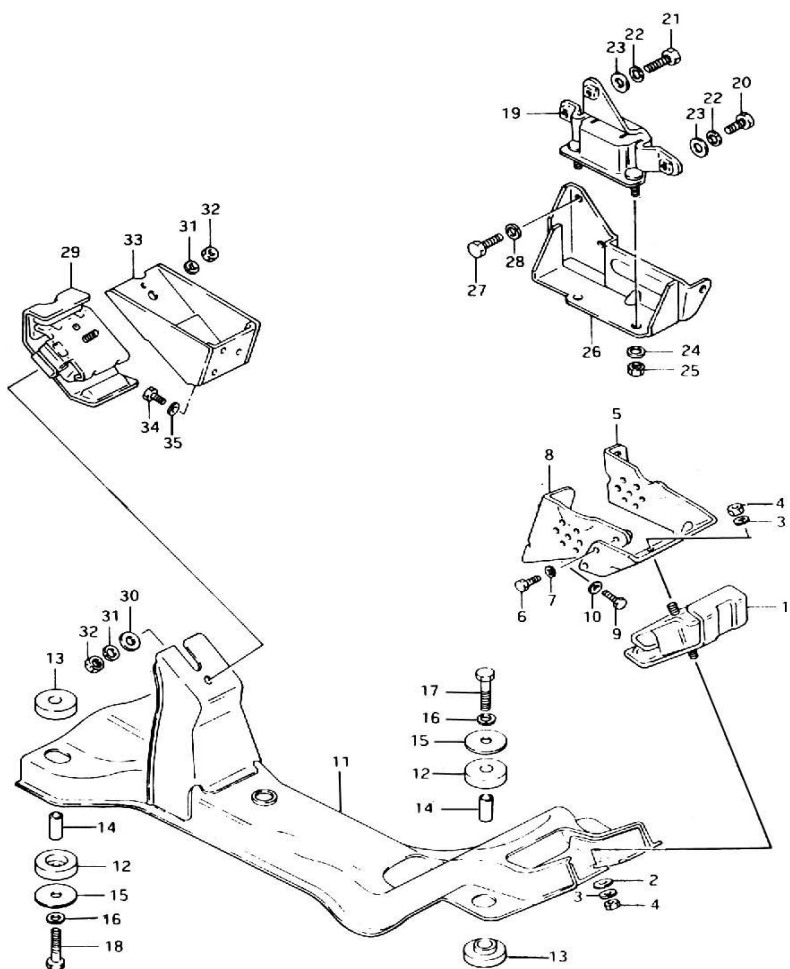

图1-21-1

序号 No.	零件序列号 PART SERIAL NO.	零部件编号 Part No.	名称 PART NAME	名称 PART NAME	数量 Qty	备注 Rem.
1	01.10.00BD004 GHH368QA1	1301010	散热器总成	Heat radiator comp.	1	BD
2	01.10.00BD005 GHH368QA1	1304010	加水口盖总成	Water filler cap comp.	1	BD
3		Q1840612	六角法兰面螺栓M6×12	Hex-bolt W/T flange M6×12	2	BD
4	01.10.00BD006 GHH368QA1	1302020	托架组件	Bracket kit.	1	BD
5		Q1840612	六角法兰面螺栓M6×12	Hex-bolt W/T flange M6×12	2	BD
6		1302011	散热器橡胶缓冲垫	Rubber buffer, heat radiator	1	BD
7	01.10.00BD007 GHH368QA1		温控开关	Thermosistor switch	1	BD
8		3745025	“o”型密封圈	O seal	1	BD
9	01.10.00BD008 GHH368QA1	1308016	风扇叶	Fan blade	1	BD
10		Q32006	螺母M6	Nut M6	1	BD

图1-21-1

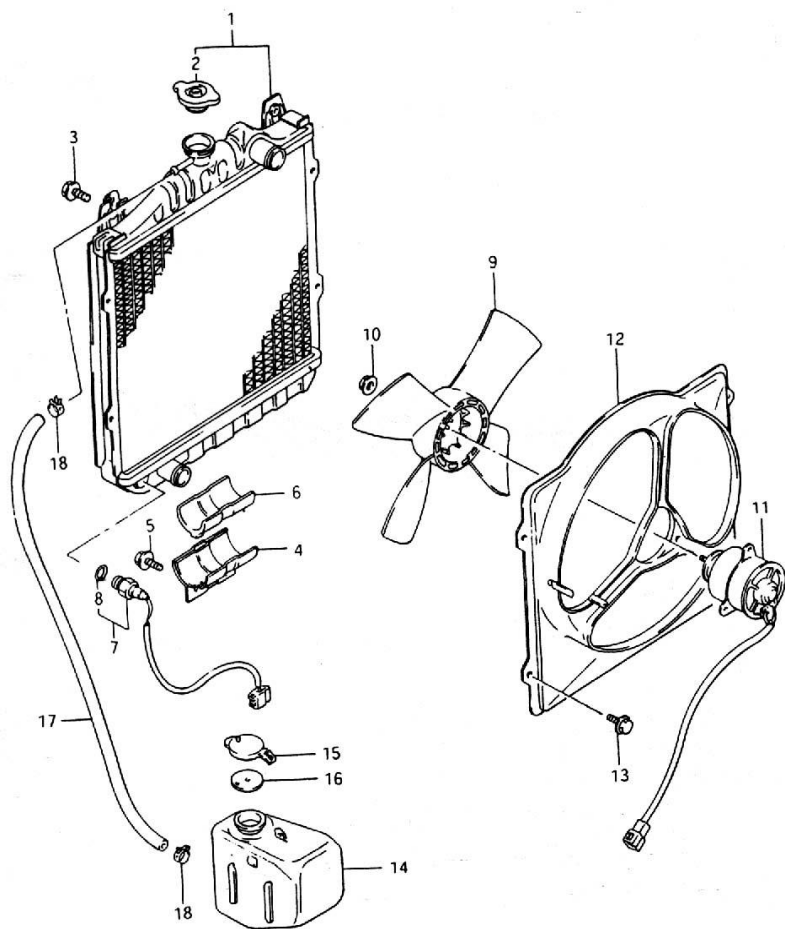

图1-21-1

序号 No.	零件序列号 PART SERIAL NO.	零部件编号 Part No.	名称 PART NAME	名称 PART NAME	数量 Qty	备注 Rem.
11	01.10.00BD009 GHH368QA1	1308010	风扇电机总成	Fan motor comp.	1	BD
12	01.10.00BD011 GHH368QA1	1308011	护风罩总成	Fan shroud comp.	2	BD
13	01.12.7083A00 4GNF	Q1840616	六角法兰面 螺栓M6×16	Hex-bolt W/T flange M6×12	4	BD
14	01.10.00BD012 GHH368QA1	1311021	溢水壶总成	Overflow tank comp.	1	BD
15	01.10.00BD013 GHH368QA1	1311022	盖子	Cap	1	BD
16		1311023	橡胶垫	Rubber cushion	1	BD
17	01.10.00BD014 GHH368QA1	1303021	散热器溢水 软管	Overflow hose, heat radiator	1	BD
18		1303022	散热器溢水 软管管夹	Clamp, heat radiator overflow hose	2	BD

图1-21-4

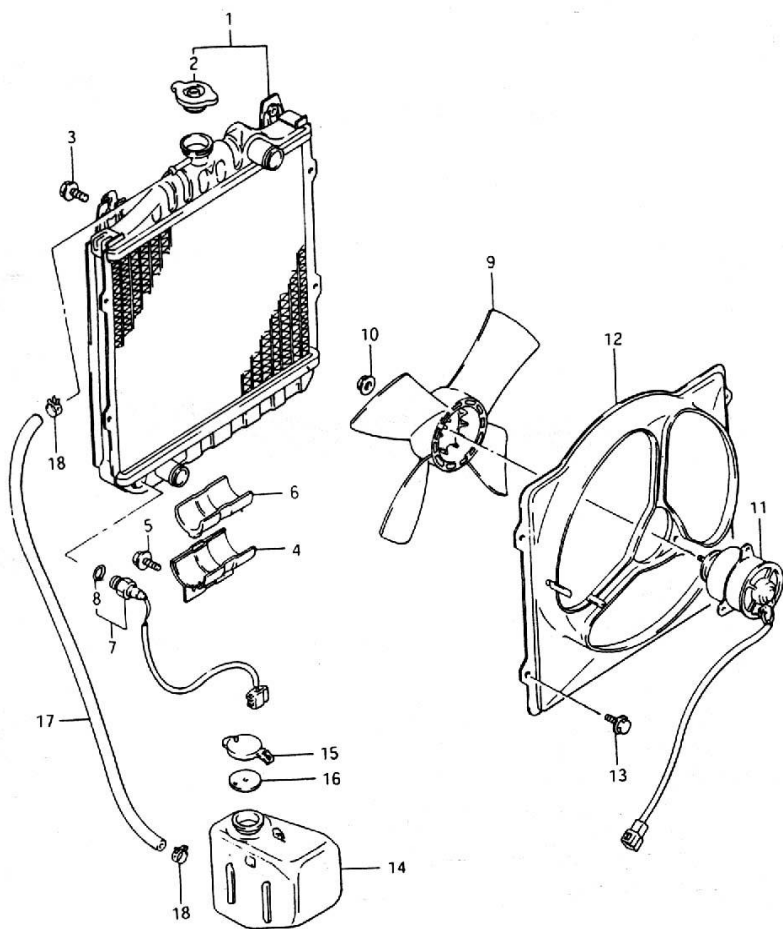

图1-21-4

序号 No.	零件序列号 PART SERIAL NO.	零部件编号 Part No.	名称 PART NAME	名称 PART NAME	数量 Qty	备注 Rem.
1		1302020-02	散热器左上支架	Upper bracket, heat radiator, L.	1	7110
2		1302021-02	散热器右上支架	Upper bracket, heat radiator, R.	1	7110
3		Q1840612	六角法兰面螺栓M6×12	Hex-bolt W/T flange M6×12	2	7110
4		1302011-02	橡胶缓冲垫	Buffer cushion, rubber	4	7110
5	01.10.7110027 GHH465Q-2E	1308010-02	风扇电机总成	Fan motor comp.	1	7110
6	01.10.7110028 GHH465Q-2E	1308016-02	风扇叶	Fan blade	1	7110
7	01.10.7110029 GHH465Q-2E	1308011-02	护风罩总成	Fan shroud comp.	1	7110
8			风扇电机	Motor, fan	1	7110
9		Q1840812	六角法兰面螺栓M8×12	Hex-bolt W/T flange M8×12	1	7110
10		Q1840612	六角法兰面螺栓M6×12	Hex-bolt W/T flange M6×12	1	7110

图1-22-1

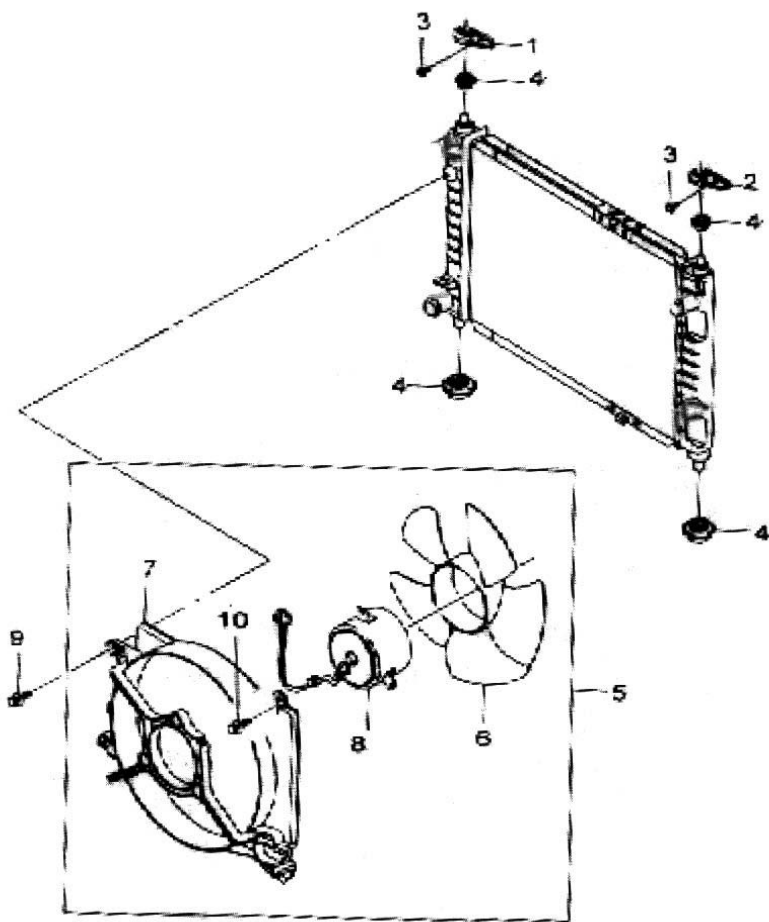

图1-22-1

序号 No.	零件序列号 PART SERIAL NO.	零部件编号 Part No.	名称 PART NAME	名称 PART NAME	数量 Qty	备注 Rem.
1	01.10.00BD015 GHH368QA1	1008029	节温器盖	Thermostat cap	1	BD
2		Q1840612	六角发兰面螺栓M6×12	Hex-bolt W/T flange M6×12	2	BD
3	01.10.00BD016 GHH368QA1	1306010	调温器总成	Thermosistor comp.	1	BD
4		1008031	密封垫	Gasket	1	BD
5	01.10.00BD017 GHH368QA1		管接头	Pipe connector	1	BD
6			进水管密封垫	Gasket, water inlet pipe	1	BD
7		Q1840612	六角发兰面螺栓M6×12	Hex-bolt W/T flange M6×12	2	BD
8	01.10.00BD018 GHH368QA1	1000151	散热器出水管总成	Water outlet pipe comp., heat radiator	1	BD
9		Q1840612	六角发兰面螺栓M6×12	Hex-bolt W/T flange M6×12	1	BD
10		Q32006	螺母M6	Nut M6	1	BD

图1-22-1

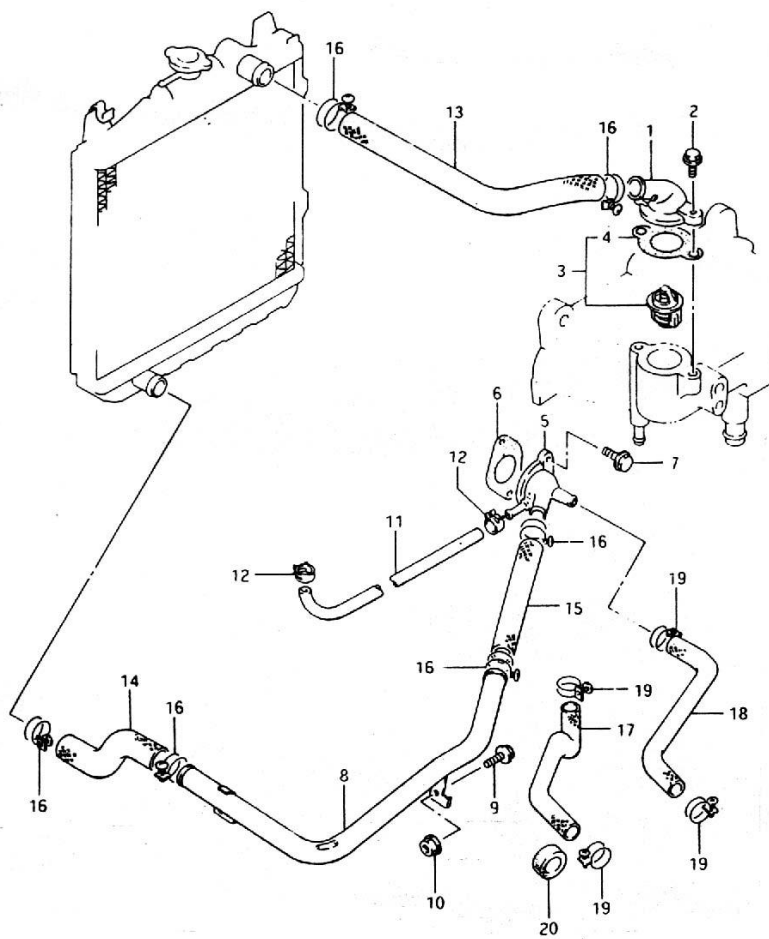

图1-22-1

序号 No.	零件序列号 PART SERIAL NO.	零部件编号 Part No.	名称 PART NAME	名称 PART NAME	数量 Qty	备注 Rem.
11	01.10.00BD019 GHH368QA1	1000043E	回水橡胶软管	Rubber hose, water return	1	BD
12			卡箍	Snap ring	2	BD
13	01.10.00BD020 GHH368QA1	1303018	散热器进水软管	Water inlet hose, heat radiator	1	BD
14	01.10.00BD021 GHH368QA1	1303012	散热器出水软管	Water outlet hose, heat radiator	2	BD
15	01.10.00BD023 GHH368QA1	1000165	进水管	Water inlet pipe	1	BD
16		1303019	卡箍	Snap ring	6	BD
17	01.10.00BD024 GHH368QA1	1303121	暖风机进水管	Water inlet pipe, heater unit	1	BD
18	01.10.00BD025 GHH368QA1	1303114	暖风机出水管	Water outlet pipe, heater unit	1	BD
19		1303122	卡箍	Snap ring	2	BD
20		1303115	卡箍	Snap ring	2	BD

图1-22-4

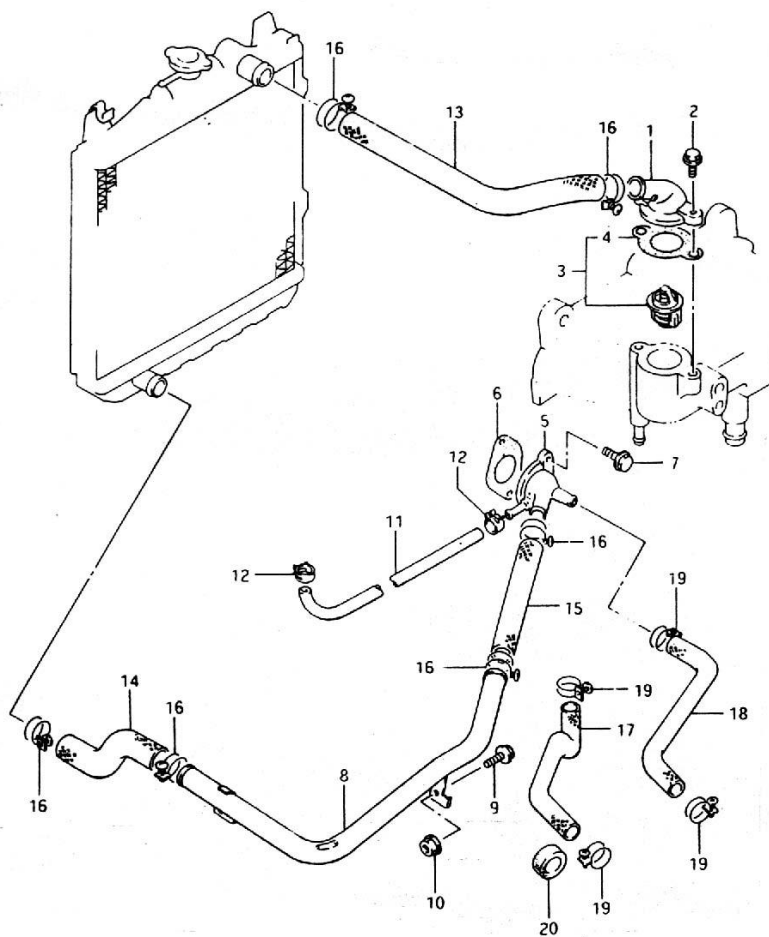

图1-22-4

序号 No.	零件序列号 PART SERIAL NO.	零部件编号 Part No.	名称 PART NAME	名称 PART NAME	数量 Qty	备注 Rem.
1	01.10.7110009 GHH465Q-2E	HH465Q·1 008029	调温器盖	House, thermosistor	1	7110
2		Q150B083 0	螺栓 M8×30	Bolt, M8×30	2	7110
3	01.10.7110010 GHH465Q-2E	HH462Q·1 306010D	调温器总成	Thermosistor comp.	1	7110
4		HH462Q·1 008031D	密封垫	Gasket	1	7110
5	01.10.7110011 GHH465Q-2E	1311010-0 2	膨胀水箱	Expansion tank	1	7110
6	01.10.7110013 GHH465Q-2E	1303021-0 2	膨胀水箱 进气软管	Intake hose, expansion tank	1	7110
7		1303022-0 2	卡箍	Snap ring	2	7110
8		1303010E	进水管焊接 总成	Welded comp., water inlet pipe	1	7110
9			螺栓	Bolt	1	7110
10			螺母	Nut	1	7110
11		1311011-1 0	膨胀水箱 出水管	Water outlet hose, expansion tank (engine water inlet hose)	1	7110
12		1311014-0 2	卡箍	Snap ring	2	7110

图1-22-4

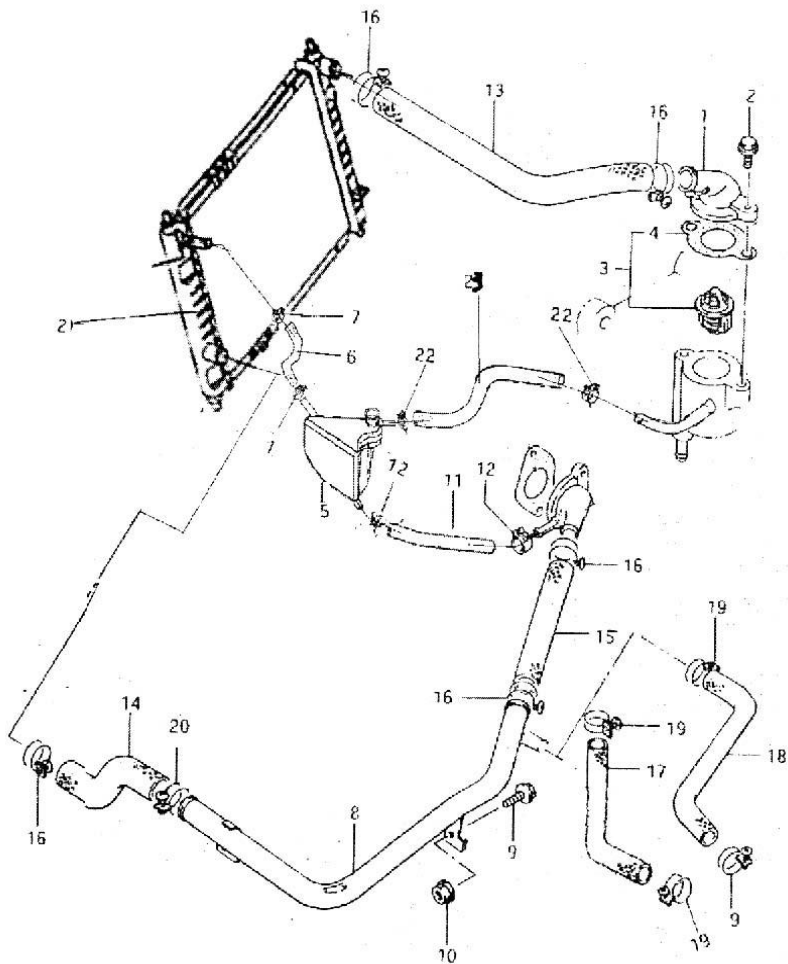

图1-22-4

序号 No.	零件序列号 PART SERIAL NO.	零部件编号 Part No.	名称 PART NAME	名称 PART NAME	数量 Qty	备注 Rem.
13	01.10.7110018 GHH465Q-2E	1303018-10	散热器进水管	Water inlet hose, heat radiator	1	7110
14	01.10.7110019 GHH465Q-2E	1303012-10	散热器出水管	Water outlet hose, heat radiator	1	7110
15	01.10.7110032 GHH465Q-2E	1000165E	进水软管	Water inlet hose	1	7110
16		1303019-02	卡箍	Snap ring	5	7110
17	01.10.7110022 GHH465Q-2E	1303121-10	暖风机进水管	Water inlet pipe, heater unit	1	7110
18	01.10.7110023 GHH465Q-2E	1303114-10	暖风机出水管	water outlet pipe, heater unit	1	7110
19		1303122-02	卡箍	Snap ring	4	7110
20		1303013-02	卡箍	Snap ring	2	7110
21	01.10.7110025 GHH465Q-2E	1303010-02	散热器	Heat radiator	1	7110
22		1303024	卡箍	Snap ring	2	7110
23		1303023	回水管	Rubber hose, water return	1	7110

图1-30-1

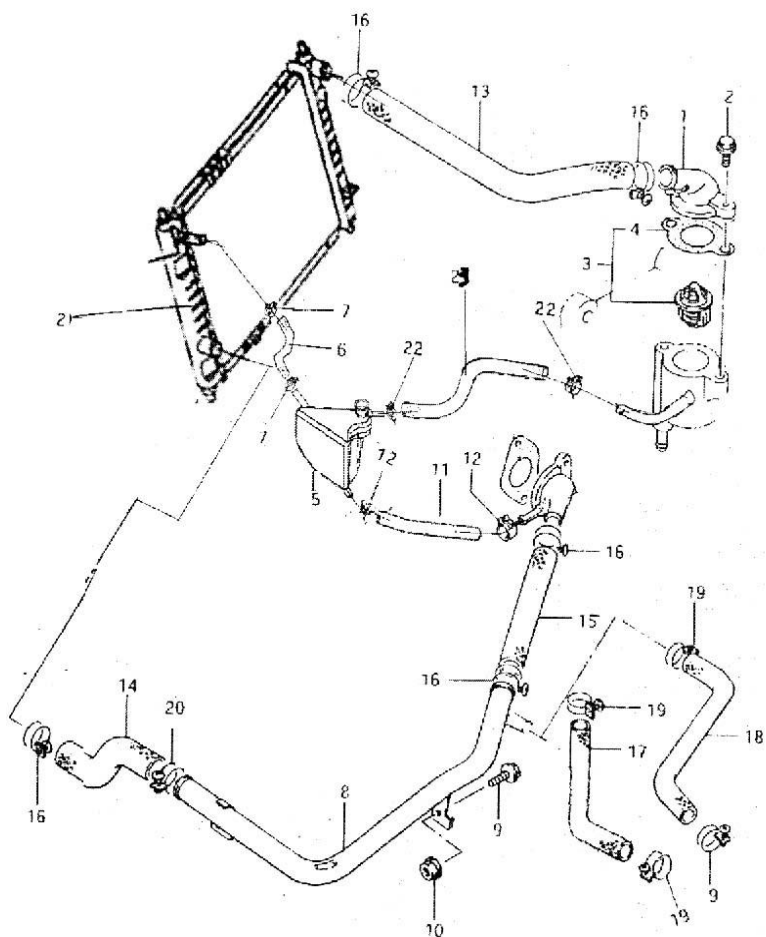

图1-30-1

序号 No.	零件序列号 PART SERIAL NO.	零部件编号 Part No.	名称 PART NAME	名称 PART NAME	数量 Qty.	备注 Rem.
1	06.09.00TY001G	1100100	燃油加油口总成	Fuel filler comp.	1	BD
2	06.09.00TY003G	1100110	加油管总成	Pipe assy., fuel filler	1	BD
3	06.09.00TY004G	1101100	燃油箱总成	Fuel tank comp.	1	BD
4	06.09.00TY001G	3806010	燃油液位传感器总成	Sensor comp., fuel level	1	BD
5	03.01.00BD001G	1106010	燃油泵总成	Fuel pump comp.	1	BD
6	06.09.00TY030G	1117010	燃油滤清器总成	Fuel filter comp.	1	BD
7		1100030	燃油滤清器支架	Bracket, fuel filter comp.	1	BD
8			带肩螺栓	Bolt W/T flange	3	BD
9	03.01.00BD004G	3600010E	燃油分配管	Pipeline, fuel distribution	1	BD
10	03.01.00TY001GHH368QA1	3600060E	燃油压力调节器总成	Fuel pressure regulator comp	1	BD
11	03.01.00BD003G	3600030E	喷油器	Fuel sprayer	3	BD
12	06.09.00TY007G	1104011	燃油管	Fuel pipe	1	BD
13		1104012	回油管	Pipe, fuel return	1	BD
14	06.09.00TY008G	1104013	排污管	Sludge drainage pipe	1	BD
15	04.01.00TY001G	1205010	碳罐总成	Charcoal canister comp.	1	BD
16	04.01.00BD001GHH368QA1	3600120E	碳罐控制阀总成	Control valve comp., charcoal canister	1	BD
17	06.09.00TY010G	1104021	1号金属油管固定夹子	Stay clamp, fuel pipe 1#	1	BD

图1-30-1

序号 No.	零件序列号 PART SERIAL NO.	零部件编号 Part No.	名称 PART NAME	名称 PART NAME	数量 Qty.	备注 Rem.
18		GB/T818—1985	螺钉M6×20	Screw M6×20	1	BD
19	06.09.00TY011G	1104022	2号金属油管固定夹子	Stay clamp, fuel pipe 2#	1	BD
20		GB/T818—1985	螺钉M6×20	Screw M6×20	1	BD
21	06.09.00TY012G	1104023	3号金属油管固定夹子	Stay clamp, fuel pipe 3#	2	BD
22	06.09.00TY014G	1104024	4号金属油管固定夹子	Stay clamp, fuel pipe 4#	3	BD
23		GB/T819—1985	螺钉	Screw	4	BD
24			螺钉	Screw	5	BD
25	06.09.00TY016G	1100041	燃油管1号盖板	Protective plate 1#, fuel pipe	1	BD
26	06.09.00TY017G	1100042	燃油管2号盖板	Protective plate 2#, fuel pipe	1	BD
27			螺钉	Screw	1	BD
28		1104033	螺母	Nut	1	BD
29	06.09.00TY018G	1104041	加油管上软管	Fuel filler hose, upper	1	BD
30	06.09.00TY019G	1104042	加油管下软管	Fuel filler hose, lower	1	BD
31	06.09.00TY020G	1104061	加油管上、下软管卡箍	Snap ring, upper & lower fuel filler hose	4	BD
32	06.09.00TY022G	1104043	进燃油滤高压软管	High pressure hose, fuel filter inlet	1	BD
33	06.09.00TY023G	1104044	出燃油滤高压软管	High pressure hose, fuel filter outlet	1	BD
34	06.09.00TY024G	1104062	燃油管卡箍	Snap ring, fuel pipe	10	BD

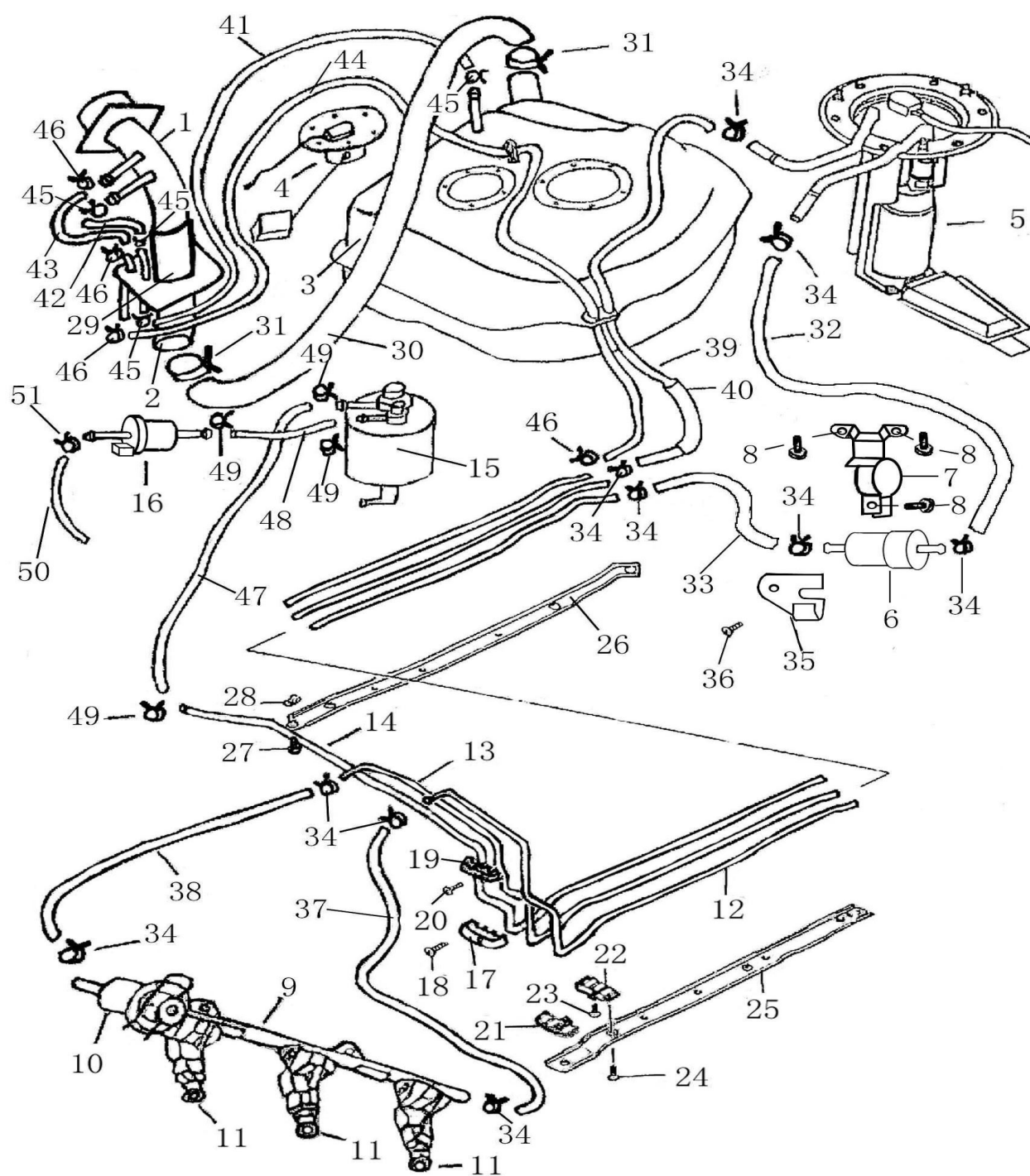
图1-30-1

序号 No.	零件序列号 PART SERIAL NO.	零部件编号 Part No.	名称 PART NAME	名称 PART NAME	数量 Qty.	备注 Rem.
35		1104063	油管夹	Clamp, fuel pipe	1	BD
36			燃油滤油管夹带肩螺栓	Bolt W/T flange, fuel filter pipeline clamp	1	BD
37	06.09.00TY025G 03.01.00TY002G	1104045	发动机进油高压软管	High pressure hose, engine fuel inlet	1	BD
38	06.09.00TY026G	1104046	调压器回油高压软管	High pressure Hose, fuel pressure regulator returning	1	BD
39	06.09.00TY027G	1104047	燃油箱回油高压软管	High pressure hose, fuel tank return	1	BD
40		1104058	管套	Sleeve	1	BD
41	06.09.00TY028G	1104048	燃油箱下通气软管(1号通气软管)	Vent hose, fuel tank, lower (vent hose 1#)	1	BD
42	06.09.00TY029G	1104049	燃油箱上通气软管(2号通气软管)	Vent hose, fuel tank, upper (vent hose 2#)	1	BD
43		1104051	燃油蒸发气上软管	Hose, fuel evaporation, upper	1	BD
44		1104052	燃油蒸发气下软管	Hose, fuel evaporation, lower	1	BD
45		1104064	通气软管卡子	Clamp, vent hose	4	BD
46		1104065	燃油蒸发气软管卡箍	Snap ring, fuel evaporation hose	4	BD
47		1205011	碳罐进气软管	Inlet hose, charcoal canister	1	BD
48		1205012	碳罐排出软管	Outlet hose, charcoal canister	1	BD
49		1205013	碳罐进、出软管卡箍	Snap ring, charcoal canister inlet & outlet hose	4	BD
50		1000162E	碳罐控制阀连接管	Pipe, charcoal canister control valve	1	BD
51		1205014	碳罐控制阀连接管卡箍	Snap ring, charcoal canister control valve pipe	2	BD

图1-30-4



图1-30-4

序号 No.	零件序列号 PART SERIAL NO.	零部件编号 Part No.	名称 PART NAME	名称 PART NAME	数量 Qty.	备注 Rem.
1	06.09.00TY001G	‘1100100’	燃油加油口总成	Fuel filler comp.	1	7110
2	06.09.00TY003G	1100110	加油管总成	Pipe assy., fuel filler	1	7110
3	06.09.00TY004G	1101100	燃油箱总成	Fuel tank comp.	1	7110
4	06.09.00TY005G	3806010	燃油液位传感器总成	Sensor comp., fuel level	1	7110
5	03.01.7110001G	25359647	燃油泵总成	Fuel pump comp.	1	7110
6	06.09.00TY030G	1117010	燃油滤清器总成	Fuel filter comp.	1	7110
7		1100030	燃油滤清器支架	Bracket, fuel filter comp.	1	7110
8			带肩螺栓	Bolt W/T flange	3	7110
9	03.01.7110003GH H465Q-2E	17202711A	燃油分配管	Pipeline, fuel distribution	1	7110
10		3600060E	燃油压力调节器总成	Fuel pressure regulator comp	1	7110
11	03.01.7110002GH H465Q-2E	3600030E	喷油器	Fuel sprayer	4	7110
12	06.09.00TY007G 06.09.7110001G	1104011	燃油管	Fuel pipe	1	7110
13		1104012	回油管	Pipe, fuel return	1	7110
14	06.09.00TY008G	1104013	排污管	Sludge drainage pipe	1	7110
15	04.01.00TY001G	1205010	碳罐总成	Charcoal canister comp.	1	7110
16		3600120E	碳罐控制阀总成	Control valve comp., charcoal canister	1	7110
17	06.09.00TY010G	1104021	1号金属油管固定夹子	Stay clamp, fuel pipe 1#	1	7110

图1-30-4

序号 No.	零件序列号 PART SERIAL NO.	零部件编号 Part No.	名称 PART NAME	名称 PART NAME	数量 Qty.	备注 Rem.
18		GB/T818— 1985	螺钉M6×20	Screw M6×20	1	7110
19	06.09.00TY011G	1104022	2号金属油管固定夹子	Stay clamp, fuel pipe 2#	1	7110
20		GB/T818— 1985	螺钉M6×20	Screw M6×20	1	7110
21	06.09.00TY012G	1104023	3号金属油管固定夹子	Stay clamp, fuel pipe 3#	2	7110
22	06.09.00TY015G	1104024	4号金属油管固定夹子	Stay clamp, fuel pipe 4#	3	7110
23		GB/T819— 1985	螺钉	Screw	4	7110
24			螺钉	Screw	5	7110
25	06.09.00TY016G	1100041	燃油管1号盖板	Protective plate 1#, fuel pipe	1	7110
26	06.09.00TY017G	1100042	燃油管2号盖板	Protective plate 2#, fuel pipe	1	7110
27			螺钉	Screw	1	7110
28		1104033	螺母	Nut	1	7110
29	06.09.00TY018G	1104041	加油管上软管	Fuel filler hose, upper	1	7110
30	06.09.00TY019G	1104042	加油管下软管	Fuel filler hose, lower	1	7110
31	06.09.00TY020G	1104061	加油管上、下软管卡箍	Snap ring, upper & lower fuel filler hose	4	7110
32	06.09.00TY022G	1104043	进燃油滤高压软管	High pressure hose, fuel filter inlet	1	7110
33	06.09.00TY023G	1104044	出燃油滤高压软管	High pressure hose, fuel filter outlet	1	7110
34	06.09.00TY024G	1104062	燃油管卡箍	Snap ring, fuel pipe	10	7110

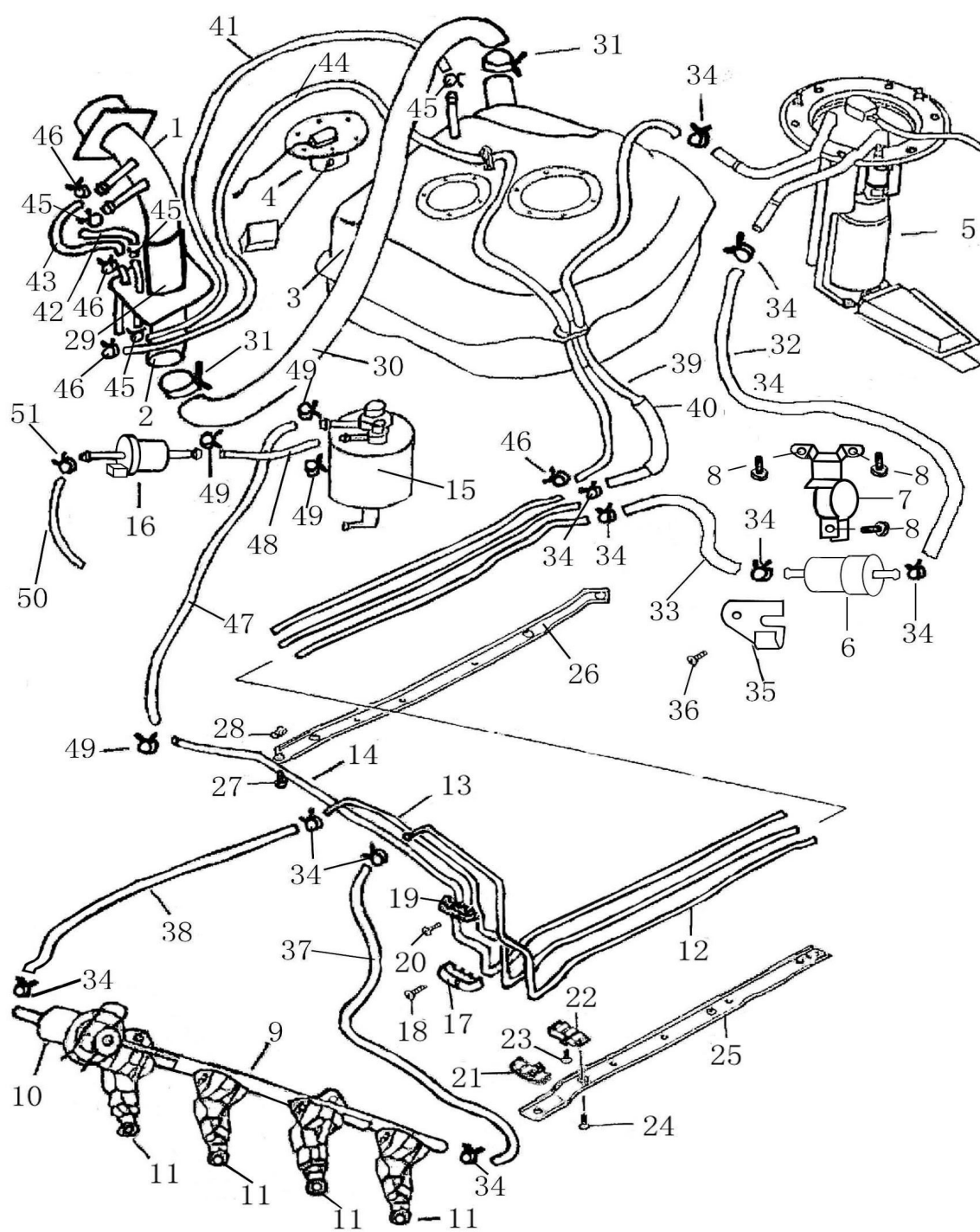
图1-30-4

序号 No.	零件序列号 PART SERIAL NO.	零部件编号 Part No.	名称 PART NAME	名称 PART NAME	数量 Qty.	备注 Rem.
35		1104063	油管夹	Clamp, fuel pipe	1	7110
36			燃油滤油管夹带肩螺栓	Bolt W/T flange, fuel filter pipeline clamp	1	7110
37	06.09.7110002G 03.01.00TY002G	1104045-10	发动机进油高压软管	High pressure hose, engine fuel inlet	1	7110
38	06.09.00TY026G	1104046	调压器回油高压软管	High pressure Hose, fuel pressure regulator returning	1	7110
39	06.09.00TY027G	1104047	燃油箱回油高压软管	High pressure hose, fuel tank return	1	7110
40		1104058	管套	Sleeve	1	7110
41	06.09.00TY028G	1104048	燃油箱下通气软管(1号通 气软管)	Vent hose, fuel tank, lower (vent hose 1#)	1	7110
42	06.09.00TY029G	1104049	燃油箱上通气软管(2号通 气软管)	Vent hose, fuel tank, upper (vent hose 2#)	1	7110
43		1104051	燃油蒸发气上软管	Hose, fuel evaporation, upper	1	7110
44		1104052	燃油蒸发气下软管	Hose, fuel evaporation, lower	1	7110
45		1104064	通气软管卡子	Clamp, vent hose	4	7110
46		1104065	燃油蒸发气软管卡箍	Snap ring, fuel evaporation hose	4	7110
47		1205011-10	碳罐进气软管	Inlet hose, charcoal canister	1	7110
48		1205012-10	碳罐排出软管	Outlet hose, charcoal canister	1	7110
49		1205013	碳罐进、出软管卡箍	Snap ring, charcoal canister inlet & outlet hose	4	7110
50		1000162E	碳罐控制阀连接管	Pipe, charcoal canister control valve	1	7110
51		1205014	碳罐控制阀连接管卡箍	Snap ring, charcoal canister control valve pipe	2	7110

图1-31-1



图1-31-1						
序号 No.	零件序列号 PART SERIAL NO.	零部件编号 Part No.	名称 PART NAME	名称 PART NAME	数量 Qty.	备注 Rem.
1		1109011	空气滤清器下壳体	Upper house, air filter	1	BD
2	01.12.00BD002GHH368QA1	1109012	滤芯	Filter core	1	BD
3		1109013	空气滤清器上壳体	Lower house, air filter	1	BD
4	01.12.00BD003GHH368QA1	1109014	进气软管	Hose, air inlet	1	BD
5	01.12.00BD004GHH368QA1	1109015	出气软管	Hose, air outlet	1	BD
6		1109016	前支架	Brace	1	BD
7		1109017	后支架	Brace	1	BD
8		1109018	卡箍	Snap ring	1	BD
9		1109019	卡箍	Snap ring	1	BD

图1-31-3

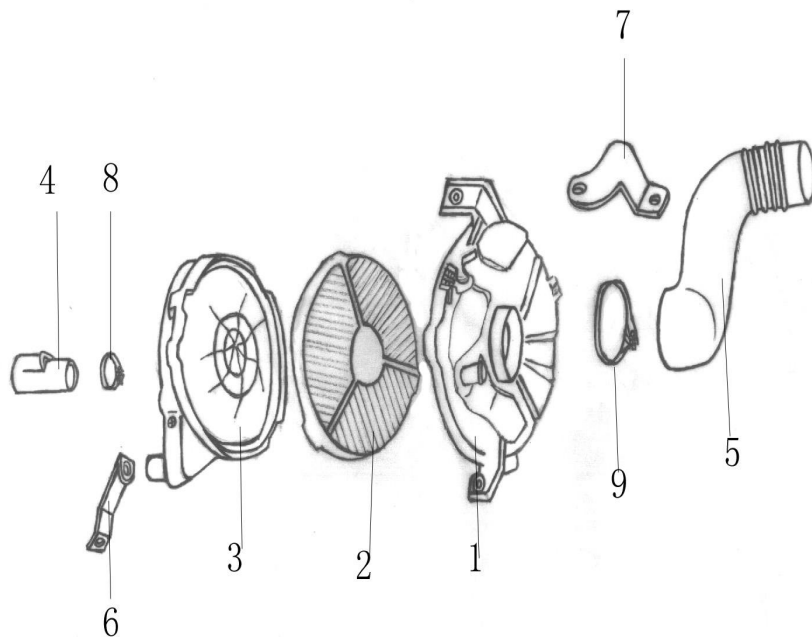

图1-31-3

序号 No.	零件序列号 PART SERIAL NO.	零部件编号 Part No.	名称 PART NAME	名称 PART NAME	数量 Qty	备注 Rem.
1		1109011-02	空气滤清器上壳体	Upper house, air filter	1	7110
2	01.12.7110002 GHH465Q-2E	1109012-02	滤芯	Filter core	1	7110
3		1109013-02	空气滤清器下壳体	Lower house, air filter	1	7110
4	01.12.7110003 GHH465Q-2E	1109014-02	进气软管	Hose, air inlet	1	7110
5	01.12.7110004 GHH465Q-2E	1109015-02	出气软管	Hose, air outlet	1	7110
6		1109016-02	侧支架	Brace	1	7110
7		1109017-02	后支架	Brace	1	7110
8		1109021-02	前支架	Brace	1	7110
9			卡子	Clip	3	7110
10		1109018-02	卡箍	Snap ring	1	7110
11		1109019-02	卡箍	Snap ring	1	7110

图1-32

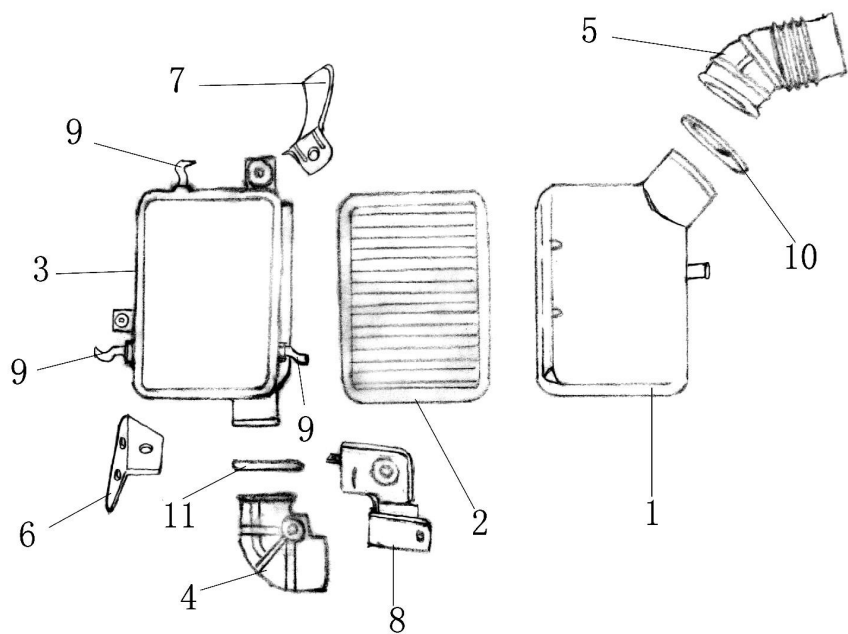

图1-32

序号 No.	零件序列号 PART SERIAL NO.	零部件编号 Part No.	名称 PART NAME	名称 PART NAME	数量 Qty	备注 Rem.
1		MT-20	电子控制器总成 (ECU)	Electrical controller comp.	1	7110
2	01.11.7110001G HH465Q-2E	12232201	进气压力温度传感器	Map/mat sensor	1	7110
3	12.01.7110003G	19005265	点火线圈	Ignition Coil	1	7110 (LJ465)
	12.01.7110004G LJ465Q-1AEN1	19005265-01				7110
4	01.11.7110002G HH465Q-2E	10456569	曲轴位置传感器	Crank sensor	1	7110
5		25351449	碳罐控制阀	Purge Solenoid	1	7110

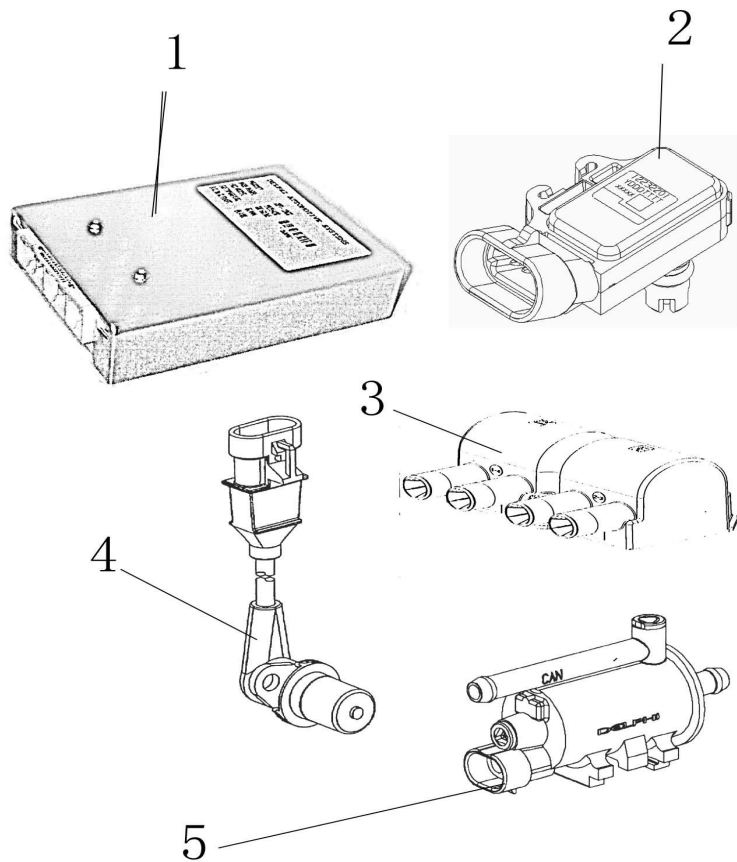