

FRAME STRUCTURE

Sephiroth Kwon

GRMA

05-20-2009

OUTLINE

- Repair Rule
- Frame Structure-Intel
 - P5 series
 - P6 series
- Frame Structure-AMD
 - AM2/ AM2+/AM3 series

Repair Rule

- 1. Voltage – CPU, Memory, PCI-E, BIOS...
- 2. Clock – CPU, Memory, PCI-E, BIOS...
- 3. Reset – CPU, Memory, PCI-E, BIOS...

- Repair Key:
 - You must know those 3 points before you repair motherboard and use those rules step by step.

FRAME STRUCTURE - INTEL

Intel-P5 series (P45 + ICH10R)

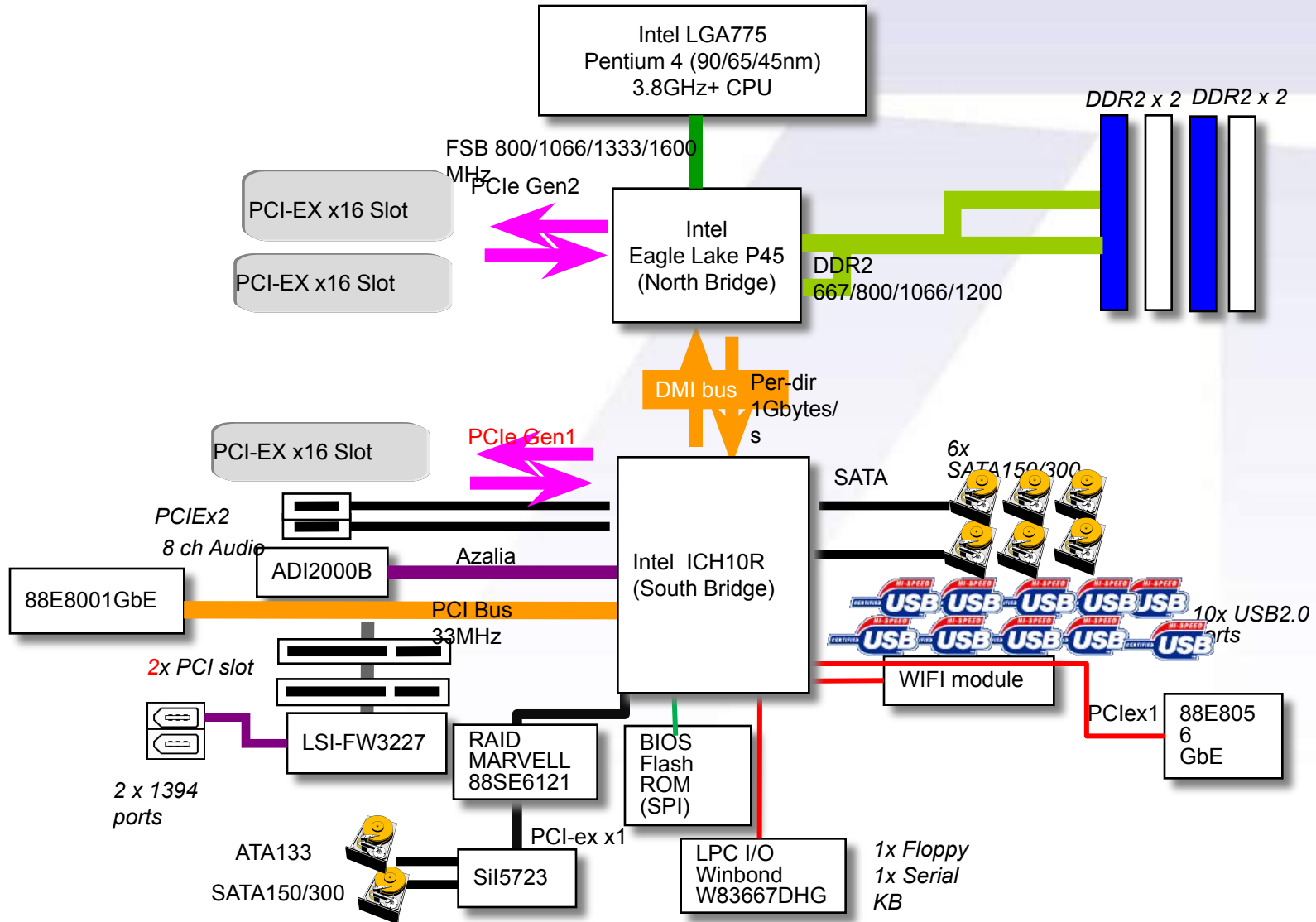

Intel-P5 series(P35 + ICH9R)

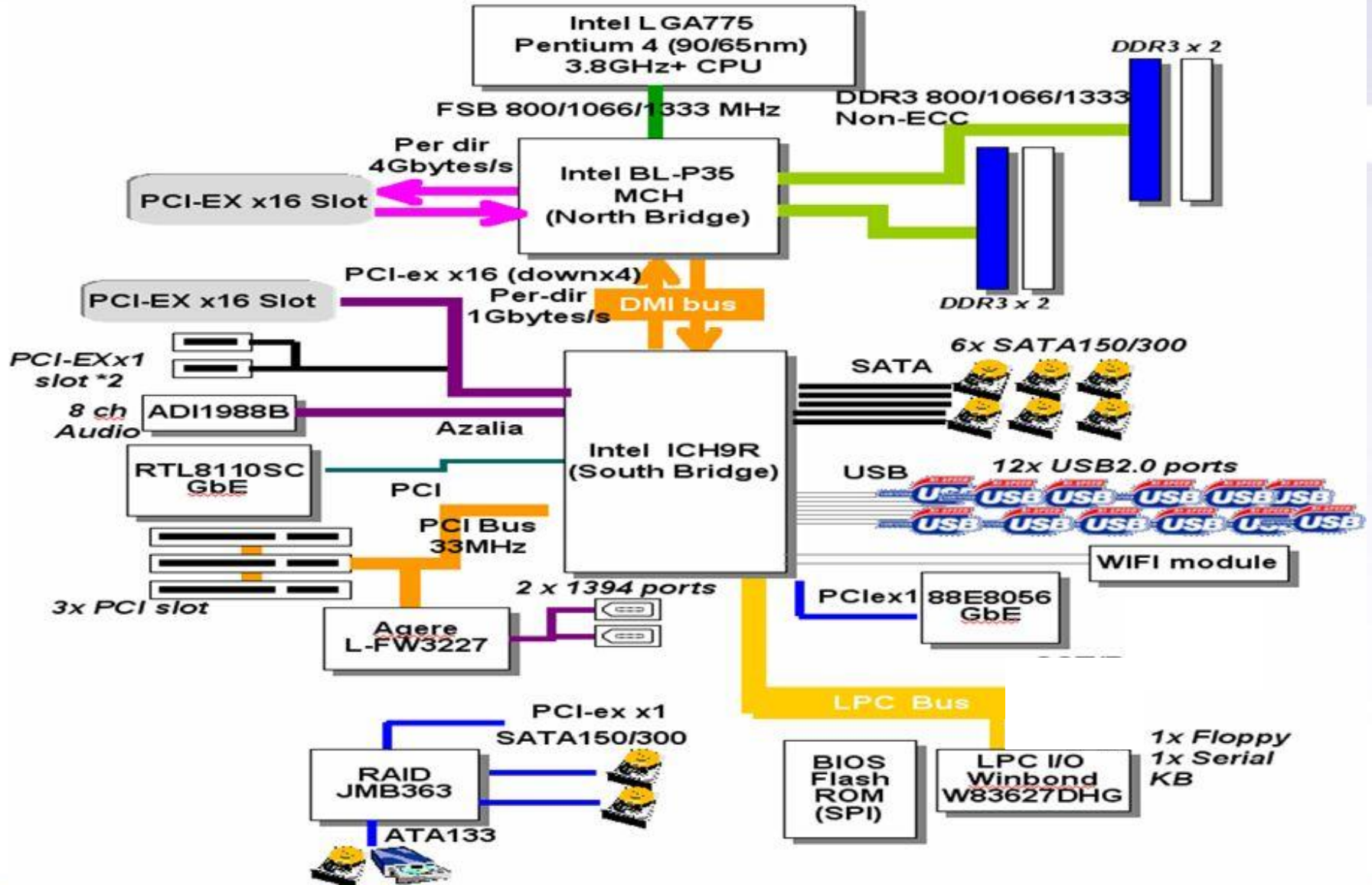

Intel-P6 series (Tylers+ICH10R)

Block Diagram

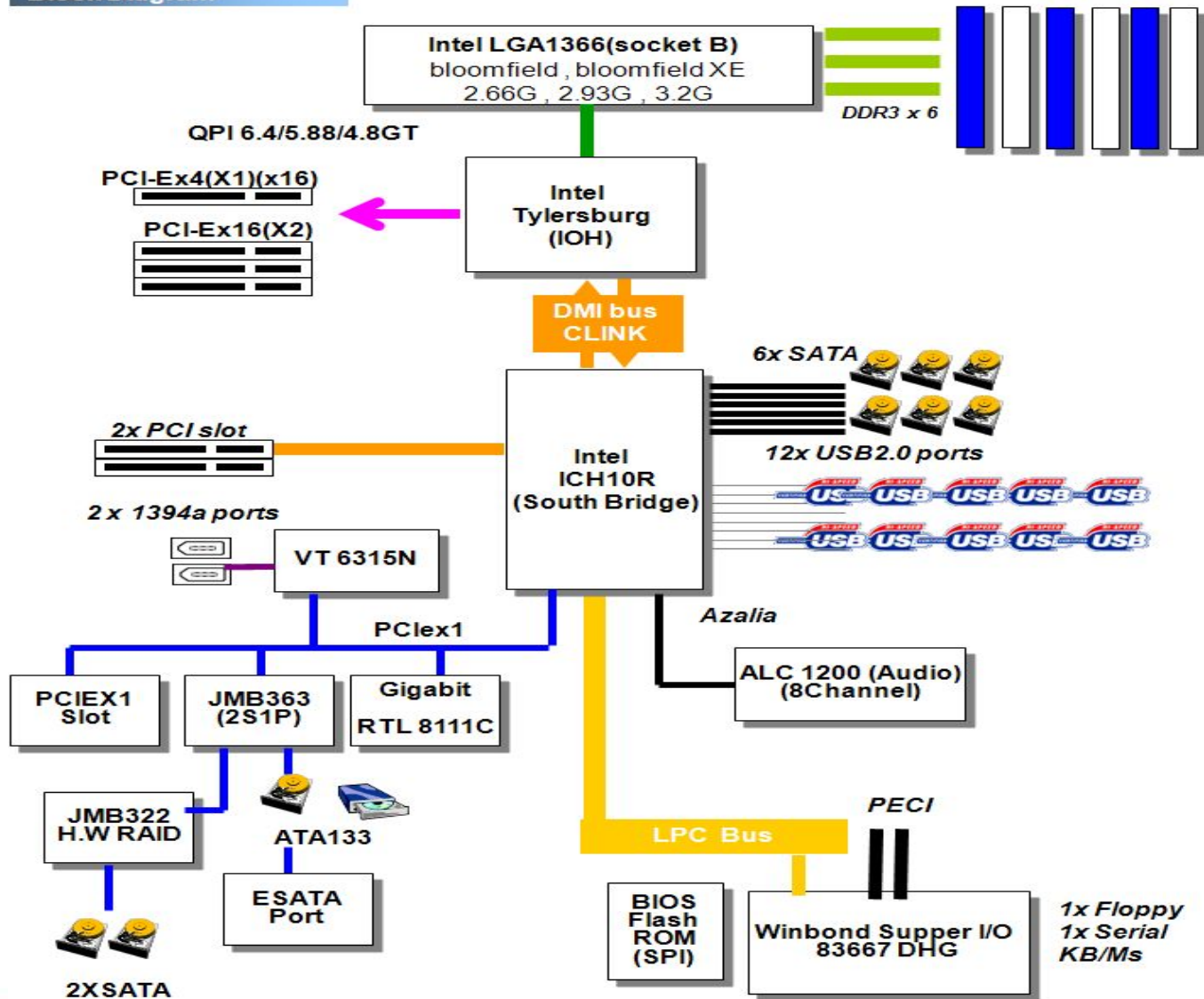

FRAME STRUCTURE - AMD

AMD-AM2 series

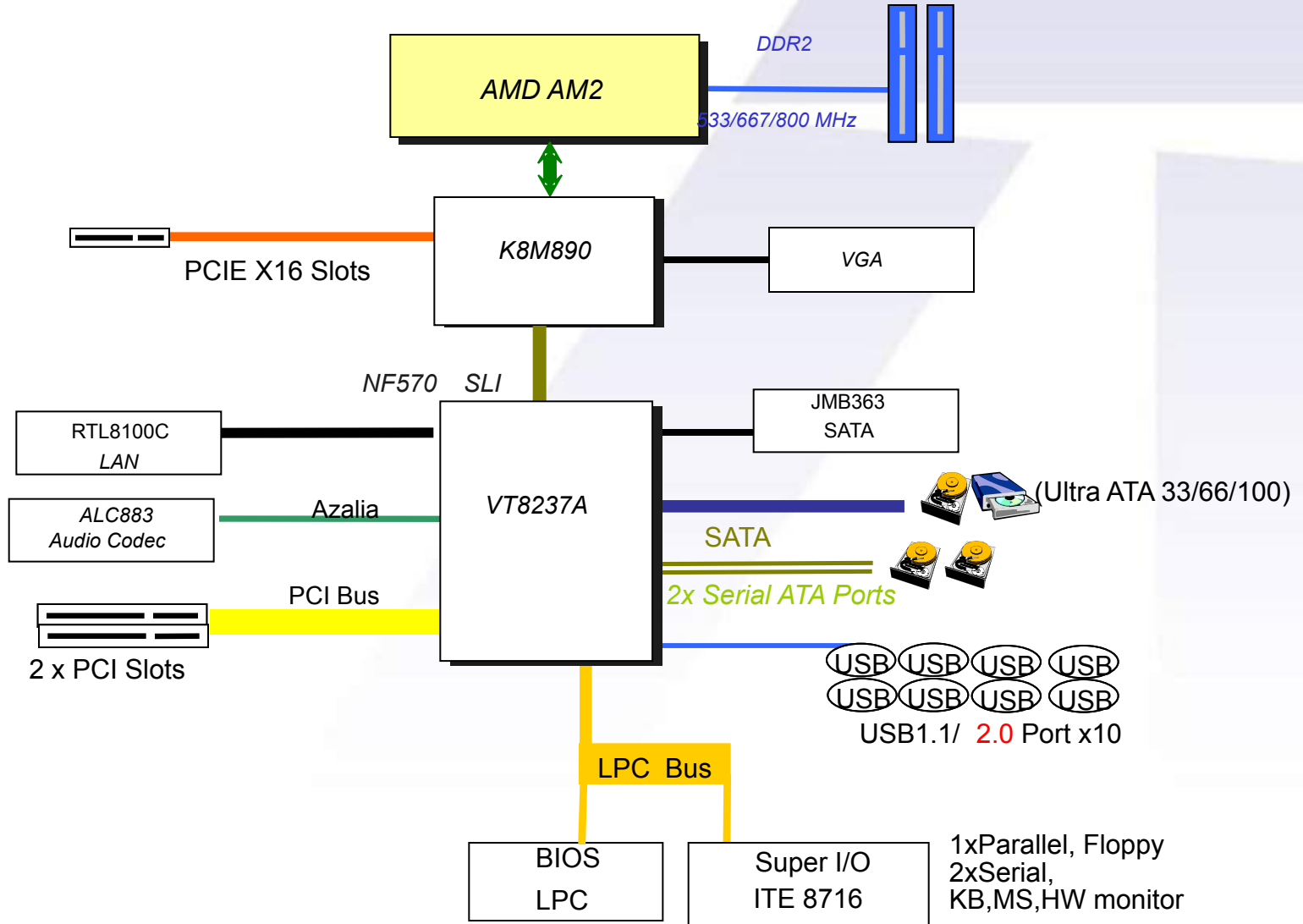

AMD-AM2 series(NF570-SLI)

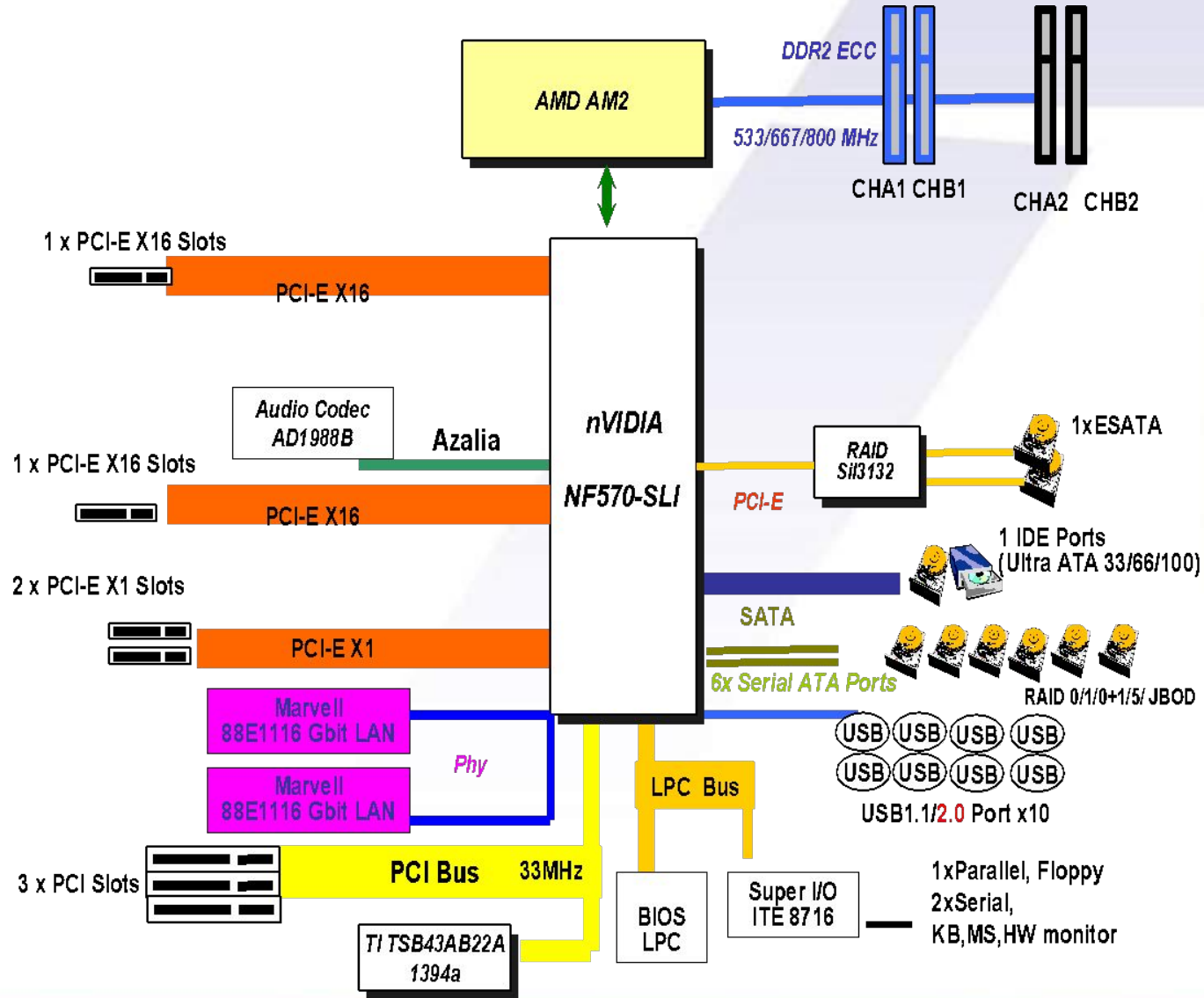

AMD-AM2+ series(790+750)

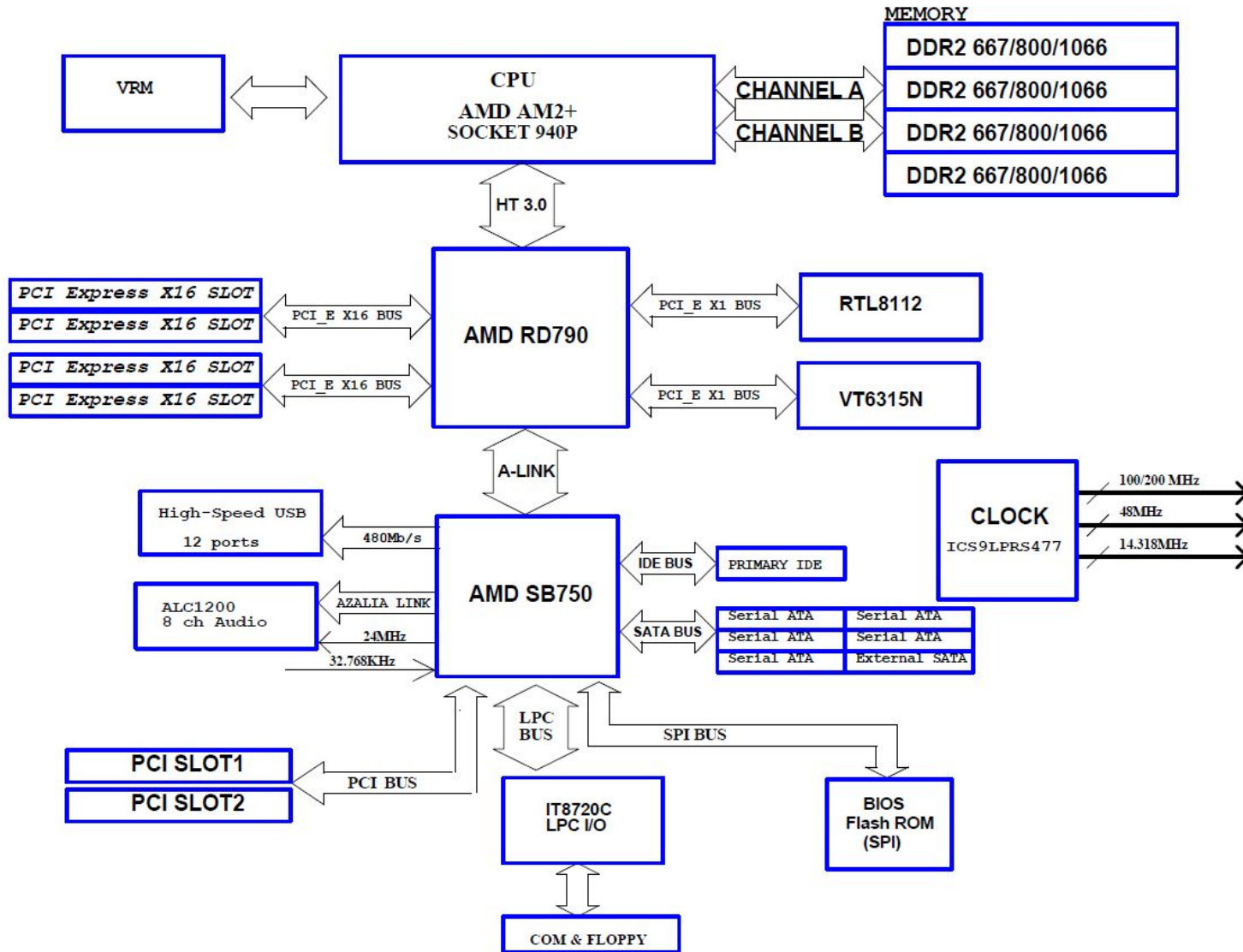

AMD-AM3 series(790+750)

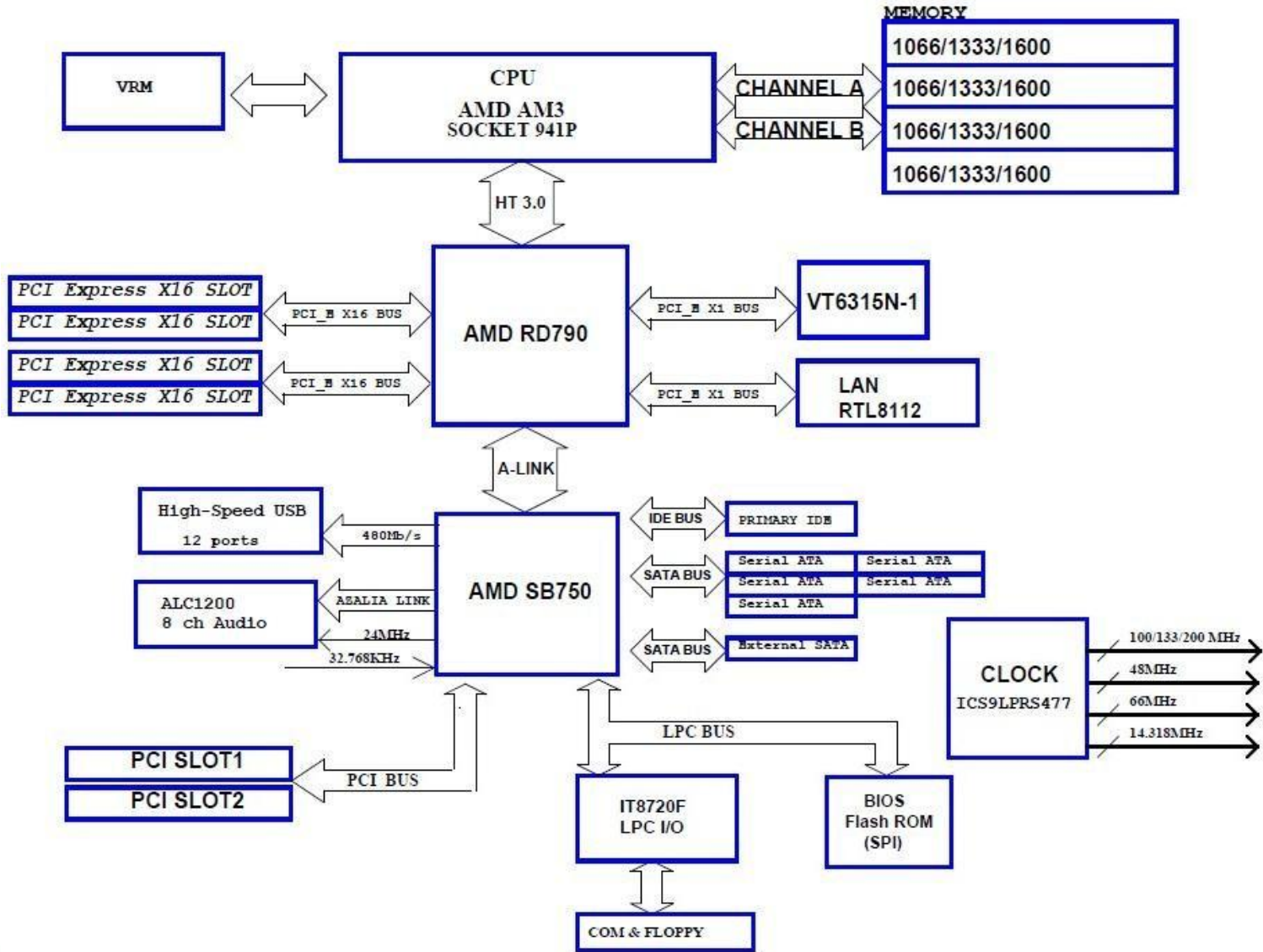

Thank You!
